

The Rockettes spread warmth and good cheer at the Radio City Christmas Spectacular

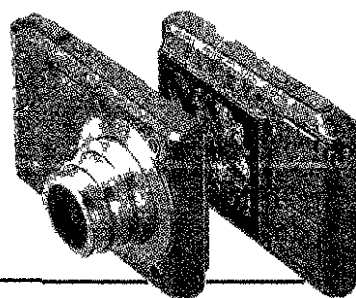

FILTER - INSERTED SECTION

Pick a perfect gift for the gadget lover in your life



AT HOME - SECTION B

Giving back
Detroit's largest Greek salad tossed at fund-raiser

TASTE - PAGE B7

THURSDAY
December 1, 2005

PLYMOUTH Observer

Your hometown newspaper serving Plymouth and Plymouth Township for 120 years

75 cents

WINNERS OF OVER 100 STATE AND NATIONAL AWARDS SINCE 2001

www.hometownlife.com

Kettle campaign sluggish

BY BRAD KADRICH
STAFF WRITER

What with people giving generously to help victims of Hurricanes Katrina and Rita, and a sluggish economy, officials at the Plymouth Salvation Army were being realistic when they set their goal for this year's Red Kettle Campaign.

After raising \$180,000 in the annual campaign a year ago, the Army set its goal at just \$155,000 this year. But if early returns are any indication, even the lower goal may be tough to make.

Red Kettle Campaign Coordinator Kelly Boelter estimated the campaign is some 20 percent behind last year at the same point. However, she said it's more an issue of volunteers than it is the generosity of the community.

"The kettles we have out there are being filled," Boelter said.

"It's just that we don't have enough people to ring the bells."

The Salvation Army mans six locations in Plymouth and another eight in Canton, and volunteers are needed at all of them.

Boelter said the preference is to have kettles manned 9 a.m. to 9 p.m. Monday-Saturday, but many shifts — particularly during weekdays — are going unmanned due to the lack of volunteers.

Volunteers must either be at least 18 years old, or they have to be paired with someone who is 18 or older.

The campaign runs through Dec. 24. Anyone who wishes to volunteer can log on to www.ringbell.org to view available locations and time slots, when the page opens, volunteers should click on 'Plymouth Community.'

Boelter pointed out bell-ringing hours can count as community service hours, a benefit particularly to students who need them.

Money raised in the campaign is used for programs within the community. The Plymouth Salvation Army services Plymouth, Canton, Northville and Belleville.

"We use it for rent and utility assistance, emergency shelter, clothing and food for people who live in our area," Boelter said.

"That's the beauty of the campaign — all money raised in this community is used in this community."

For more information, go to the Web site or call Boelter at (734) 453-5464.

bkadrich@hometownlife.com
(734) 459-2700



The Plymouth community welcomed Santa Claus back to town in the annual greeting ceremony in Kellogg Park Friday night.

Welcome back, Santa

Crowd turns out to usher in holiday season

BY BRAD KADRICH
STAFF WRITER

Having grown up in Plymouth, Jenny Kroll is no stranger to the events many believe give Plymouth its small-town charm.

On Friday, she gave her children a small dose of it, singing Christmas carols and drinking hot chocolate as they welcomed Santa to the city.

Absolutely this is a small-town tradition, said Kroll, attending the annual welcoming with her children, 6-year-old Alex and 4-year-old Alyssa.

Santa arrived a few minutes early, courtesy of a ride from the Plymouth Community Fire Department, to a chorus of carols being led by Bill Pratt of Management and Tax Services, the master of ceremonies for the

'It's fun, the kids love it. I think this kind of small-town charm is what makes Plymouth such a success.'

Dan Dwyer
mayor

evening. Santa himself led the hundreds gathered in chilly Kellogg Park in a rendition of *Rudolph the Red-Nosed Reindeer* before throwing the switch to light up the official Christmas tree.

"It's always a pleasure to come back to Plymouth," Santa said as he accepted the traditional key to the hearts of Plymouth's boys and girls.

"We always enjoy coming here."

Santa then retired to his "house" on the outskirts of the park, where he received visitors of all ages. Santa visits will be available weekends through Dec. 23. Hours are 5-8 p.m. Fridays, noon to 5 p.m. Saturdays and Sundays.

It's an event welcomed by the city's new mayor, as well. Mayor Dan Dwyer has been to the event the last several years, and marvels at its charm.

"I was talking to a man and telling him about this, and he said, 'You guys do that here?'" Dwyer said. "It's fun, the kids love it. I think this kind of small-town charm is what makes Plymouth such a success."

bkadrich@hometownlife.com
(734) 459-2700

Network helps cops find kids, elderly

BY BRAD KADRICH
STAFF WRITER

When a Plymouth resident out walking his dog one chilly day a few weeks ago found a man laying in his back yard clad only in long-john underwear, he turned to the city's police department for help.

The police, in turn, used a tool provided by an organization — A Child is Missing Alert — they'd joined only the day before.

ACIM, based in Fort Lauderdale, Fla., uses a sophisticated computer satellite mapping program and can make some 1,000 computerized telephone calls per minute. Established in 1997, ACIM has narrowed the time frame from making those 1,000 calls in two hours to making them in 60 seconds.

The recorded calls are made to residents in the local area, giving police an avenue with which to provide information. ACIM's primary goal, recovering missing children, has been accomplished as quickly as eight minutes in some cases.

"Any time you've got a child missing, the first thing you want to do is get information out," said Plymouth Police Chief Wayne Carroll. "The more information we can get out to our citizens, the better we're doing our job. It's another tool for us."

In the city's case, the tool was used to try to identify the older gentleman found in the resident's yard. He was taken to a hospital, the ACIM system was alerted and the calls went out. According to Carroll, some calls had already come in, though no one could identify the man, when detectives were able to talk to him at the hospital and determine his identity.

While it turned out the ACIM system wasn't needed to identify the man, Carroll said the fact it was used — and produced responses — shows the

PLEASE SEE NETWORK, A3

Web site expands to serve growing audience

The *Observer & Eccentric* has a new look on the World Wide Web.

Visit hometownlife.com for a redesigned, colorful, easy-to-use new Web site. The new hometownlife.com offers many new features, including nearly all local news and photographs contained in print editions of the *O&E*. And the addition of careerbuilder.com, apartments.com and homescape.com, a network offering more than 23,000 local real estate listings, will mean market-proven tools for advertisers and Web users.

Our new, revamped Web site gives us a wonderful opportunity to provide readers and advertisers a new information platform on a 24/7 basis," said Peter Neill, general

manager of the O&E.

"It is an extension of what we do in what has become for us the information business. The culture of our business is rapidly changing as is the sophistication of our online users, readers and advertisers. It is the online user, reader and advertiser who dictates what they want to see and when they want to see it," said Neill.

"The changes to our Web site are tremendously beneficial for our readers and advertisers," added Marty Carry, director of advertising at the *O&E*. "And the enhancements to our online classified products are very powerful."

"If you are a business owner or manager and need to hire, we can now provide you with

worldwide exposure on careerbuilder.com. Our online real estate offering has also improved and is one of the best in the state. The bottom line for our classified readers and advertisers is we will continue to be your best source for local classifieds and now we can provide you with worldwide reach online with several categories."

EXTEND YOUR REACH

Putting your ad online expands your reach and keeps you connected to customers, Carry added.

The *Observer & Eccentric Newspapers* is now owned by the Gannett Co., a leader in print, broadcast and Web-

PLEASE SEE WEB SITE, A5

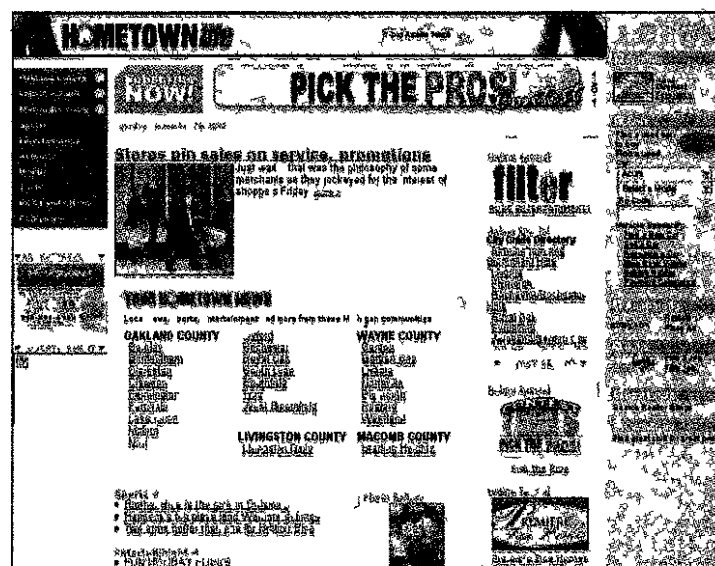

The new hometownlife.com offers many new features, including nearly all local news and photographs contained in print editions of the *Observer & Eccentric Newspapers*.

© The Observer & Eccentric Newspapers

Volume 120
Number 29



For Home Delivery call:
(866) 887-2737

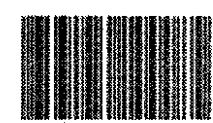

6 63174 10008 5

1 Year Certificate
with rates as high as
4.45%
Annual Percentage Yield



COMMUNITY FINANCIAL

Thinking forward Banking right

(734) 453-1200 (877) 937-2328 toll free www.cfu.org

PLYMOUTH CANTON NORTHVILLE NOVI

Minimum deposit required is \$100. Rates are 4.45% for 12 months. Subject to change. APY is based on a 360-day year. Actual APY may vary. See your branch for details. Equal Housing Lender. Member FDIC. Community Financial is a member of the National Credit Union Administration. ©2005 Community Financial.

INDEX

APARTMENTS	F5
AT HOME	B1
BELIEFS & VALUES	B5
AUTOMOTIVE	F6
CROSSWORD	F8
JOBS	G1
MOVIES	D13
OBITUARIES	B5
REAL ESTATE	F1
SERVICE GUIDE	G4
SPORTS	C1
TASTE	B7

Coming Sunday
on the PINK Page



Make your holiday 'glam plan'

Medicare program

State Sen Bruce Patterson, R-Canton, and U S Rep Thaddeus McCotter, R-Livonia will sponsor a program to provide information on the new Medicare Prescription Drug Program at 9:30 a.m. Wednesday, Dec 7 at the Plymouth District Library. A representative from Senior Alliance, Ron Lieberman, will provide information on the Medicare programs offered and will answer questions. The Plymouth District Library is located at 223 S Main St in downtown Plymouth.

Open mic night

The Plymouth Coffee Bean presents Monday Nights in the Orange Room, a super-fine acoustic music and spoken word open-mic time hosted by Sean FitzGerald. Open mic night runs Mondays 8-11 a.m., sign-up can be done via e-mail at Beanopenmic@hotmail.com or in person. The Plymouth Coffee Bean is open until midnight. It is located at 884 Penniman in downtown Plymouth. For more information, call

(734) 454-0178
Breakfast with Bruce

All seniors are invited for a complimentary breakfast with state Sen Bruce Patterson, R-Canton. No RSVP required. This free breakfast will be offered at the Central City Diner, 6600 N Canton Center (between Ford Road and Warren) in Canton 9-10 a.m. Monday, Dec 5.

For more information, call the diner at (734) 354-9100, or Patterson's district director, Sue Trussell, (734) 783-1642.

Credit score seminar

The Plymouth District Library will host a special "Sense and Sense" meeting 1-2:30 p.m. Wednesday, Dec 7, to examine the issue of credit card scores.

Helen Pianowski, assistant manager of lending for Community Financial in Plymouth, will explain what is a good score, the different types of credit scores, and give some helpful tips to polish up credit scores.

The three-digit credit score (also known as a FICO score) is the magic number that determines qualification for a mort-

gage or home equity loan, opening a credit card, starting cell phone service, insurance rates, or even renting an apartment. For more information, contact the library at (734) 453-0750.

DAR meeting

The Daughters of the American Revolution meet 11 a.m. Monday, Dec 19, at Greenmead Hill House in Livonia. Sue Daniels will talk about the Christmas tea.

For more information, call (734) 459-4764.

Art exhibit

Sherrus Gallery of Fine Art hosts a joint exhibit featuring two Michigan artists - abstract artist Shadia Sassak and glass artist Vic Leo.

The exhibition and sale opens Friday, Dec 2 with a wine and cheese reception from 6-9 p.m., the exhibit continues on display through the end of December.

Sherrus Gallery of Fine Art features original oils, acrylics, sculpture and fine art glass created by national and international established and emerging artists. Sherrus Gallery is located at 109 N Center in downtown Northville. For more information, call (248) 380-0470.

PCAC art exhibit

The Plymouth Community Arts Council presents the work



Holidays in Music

The Plymouth District Library, with the support of the Friends of the Library presents 'Winter Holidays in Music and Poetry' 2 p.m. Sunday, Dec 4. Acoustic guitarists David Cocagne and Michael Blaskiewicz of the Troubadours will provide seasonal music as such winter celebrations as Christmas, Hanukkah, Epiphany, Eid al-Adha and Carnavale are highlighted. Refreshments will be served. Call the Reader's Advisory Desk, (734) 453-0750, Ext 4, to register.

of Walled Lake artist Rodney Lloyd Dec 1-23.

Oil paintings and pottery will be featured in the exhibit entitled, "Nature Redesigned: Old and New Life Forms of the Earth, Air and Sea."

A reception will be held for the artist 6-8 p.m. Saturday, Dec 10. The public is invited to attend.

Lloyd worked as a car designer for Ford and Chrysler for many years. He was involved with the original designs for the Mustang and

the Chrysler mini-vans. He has also taught design at the College for Creative Studies.

His creativity also embraces nature in the form of very colorful, abstract oil paintings. The dynamic use of color, organic forms and unusual composition is central to the artist's vision. His work is included in many private and corporate collections.

The Plymouth Community Arts Council is located at 774 N Sheldon in Plymouth. Exhibit hours are 10 a.m.-5 p.m. Monday, Tuesday, Thursday and Friday, 10 a.m.-8 p.m. Wednesday, and 9 a.m.-noon Saturday. Call (734) 416-4278 for

additional information
Computer classes

Residents of Plymouth and Plymouth Township are invited to expand their computer knowledge in a series of free classes at the library.

Available classes include Google Tips, 7 p.m. Thursday, Dec 1, basic e-mail, 1 p.m. Monday, Dec 5, Internet searching, 7 p.m. Thursday, Dec 8, drop-in computer tutoring, 10 a.m.-1 p.m. Saturday, Dec 10, computer basics, 1 p.m. Wednesday, Dec 14.

Space is limited, register by calling (734) 453-0750, Ext 4.

Holiday gift fair

United Home Health Services, a nonprofit home care company located in Canton, is hosting a Holiday Gift & Craft Fair 11 a.m.-2 p.m. Friday, Dec 2 at their office located at 2200 Canton Center, Suite 250.

A portion of the proceeds will be donated to United's Patient Support Fund, which is designated for their home care patients who need basic items such as food, clothing, or emergency medications or medical equipment such as walkers, canes, or commodes that they just cannot afford. This fund is also used to provide home care for patients who do not have medical insurance.

All are welcome to attend. Donations to this fund are also being accepted. For more information, call (734) 981-8820.

Observer

WHERE HOMETOWN STORIES UNFOLD
GANNETT HOMETOWNLIFE.COM

HOW TO REACH US

Newsroom (734) 459 2700 Fax (734) 459 4224
Sports Nightline (734) 953 2104
Circulation/Customer Service ... 1 866 88 PAPER (866 887 2737)
Classified Advertising 1 800 579 SELL (7355)
Display Advertising (734) 953 2153

POSTAL PERIODICAL REQUIREMENTS

The Plymouth Observer Publication NO USPS 436 360 Published every Thursday and Sunday. Periodical postage is paid at Livonia a Michigan 48150.

36251 Schoolcraft Livonia MI 48150

Save 10% on Every Part. Use promo code CANOBS online or bring it to our Parts Counter. Expires Dec 31, 05.

Do it yourself... Free Appliance Repair Help

www.RepairClinic.com

1-800-269-2609

48600 Michigan Avenue Canton (1/4 mile west of Beck Rd.)

PLYMOUTH-CANTON COMMUNITY SCHOOLS

NOTICE TO BIDDERS

The Board of Education of the Plymouth-Canton Community Schools invites all interested and qualified companies to submit a bid for an **Employment Assistance Program (EAP)** for the District. Specifications and bid forms are available by contacting Brenda Armour, Senior Benefit Analyst at The Raines Group at 248 502 1108 or via e-mail at Brenda.Armour@therainesgroup.com. For other information, please contact Dan Phillips in the PCCS Purchasing Department at (734) 416 2746. Sealed bids are due to the E.J. McClendon Building 454 South Harvey, Plymouth MI 48154 on or before 1:00 p.m. Friday December 9 2005 where they will be read publicly. The Board of Education reserves the right to accept and/or reject all bids as they judge to be in the best interest of the school.

Board of Education
Plymouth Canton Community Schools
JOANNE LAMAR, Secretary

Publish: November 24 & December 1 2005

Sherwood Forest Designs

Unique, One of a Kind Jewelry Designs

Head-to-Wrist-to-Ankle Accessories

Sterling Silver, Crystal, Gemstone, Vermeil Custom Designs
Bridal or Any Special Occasion
Jean Charms, Book Marks, Sun Catchers, too!

OPEN SAT, DEC 3 AND SUN, DEC 4
NOON-6 PM

126 Montague St., Belleville 734-751-4925
Email: lunafadyhawke@comcast.net

CHARTER TOWNSHIP OF CANTON

ACCESS TO PUBLIC MEETINGS

The Charter Township of Canton will provide necessary reasonable auxiliary aids and services, such as signers for the hearing impaired and audio tapes of printed materials being considered at the meeting to individuals with disabilities at the meeting/hearing upon two weeks notice to the Charter Township of Canton. Individuals with disabilities requiring auxiliary aids or services should contact the Charter Township of Canton by writing or calling the following:

David Medley ADA Coordinator
Charter Township of Canton 1160 S Canton Center Road
Canton MI 48188
(734) 394 5260

Publish: December 1 2005

NOTICE

CITY OF PLYMOUTH, MICHIGAN

WINTER TAXES - 2005

Winter taxes are due December 1 2005 and payable through February 28, 2006 without penalty. Additional information appears on the reverse side of your tax statement. **MAKE ALL CHECKS PAYABLE TO: CITY OF PLYMOUTH.** Payments can be made at City Hall during regular working hours Monday-Friday 8:00 a.m. - 4:30 p.m. at the Treasurer's office. After hours payments can be placed in the drop box located in the City Hall lobby (Church Street entrance) or in the payment drop box next to the book returns behind the Library.

CITY HALL WILL BE CLOSED during the Christmas Holidays from Friday December 23 2005 through Monday January 2, 2006. The Treasurer's office will be **OPEN TO ACCEPT TAX PAYMENTS AND OTHER PAYMENTS** on Wednesday December 28th and Thursday, December 29th.

Teresa Cischke CPFA
City Treasurer

Publish: December 1 & 4 2005

Physical Therapy UPDATE

Hands On Center
Presented by Hands On Center For Physical Therapy

EXERCISE GUIDELINES FOR WOMEN

Until recently the only exercise guidelines available were based on men and it was not certain whether they also applied to women. However, as more women are being included in medical research, gender differences in some diseases and other health issues are emerging. For the first time, researchers have established how much exercise women should be able to do for their age and found that their capacity is slightly lower than men's. It also declines a bit faster than men's as they grow older. While fitness levels decline for everyone, the research shows that the difference between men and women becomes more pronounced with age. Women lose about one percent of their exercise capacity per year according to the study.

As a woman, you are unique. You have your own special needs and concerns. That's why we know you will appreciate the personal care our practice provides. For further information about today's column, contact us at **HANDS ON CENTER FOR PHYSICAL THERAPY** at 455 8370. We are located at 650 South Main Street in downtown Plymouth. We have easy access and parking. New patients are gladly accepted.

PS: Women are encouraged to aim for an exercise capacity of at least 85% of what it should be.

Johan Comuth, PT
Mark Minsbergen, PT
Beth Schoemaker, PT

Plymouth Jewelry & Gifts

If you get her something more practical, she'll love you no less.

But the way she shows her love might be more well practical you could say.

Plymouth Jewelry & Gifts

IN THE OLD VILLAGE
620 STARKWEATHER
734-453-1860

Tues Wed 10-6 Th & Fri 10-8 Sat 10-5 • Closed Sun & Mon

www.plymouthjewelry.com

Who do you think you're talking to?

Mark Savitskie is someone worth knowing. It's true that he understands numbers and mortgages, but Mark is also worth knowing because he's someone you can count on, someone you can trust.

As owner of Allegro Home Loans in Plymouth, he has proven that time and again at the closing table. And, as a long-time (24 years!) Plymouth resident, local parishioner, athletic coach and member of the Plymouth Rotary Club, he has demonstrated that consistently in his everyday life.

"For me, business is personal—you can't separate the two. Even more than impressive professional credentials, good business is all about personal integrity."

Mark Savitskie knows what he's talking about.

Allegro Home Loans

Call us today for your **FREE CONSULTATION**
(734) 254-9640

670 S. Main Street • Plymouth, MI 48170
mark@allegrohommelans.com

Psst...you too can hide all of your presents at my secret hiding place...

AMERICA'S BUDGET STORAGE!!

Tell them Santa sent you in to rent a 5x10 for the month of December for just... \$25 that's half price!*
(Regular rates resume Jan. 1, 2006)

Specials also available on other sizes.

Don't forget, they also have packing supplies to ship all your gifts, too! Including a wide variety of boxes.

Stop by today and let one of my friendly elves help you keep your gifts a secret.

Located at:
40671 Joy Road • Canton • Between Haggerty and I-275

734-459-6444

*Coupon must be presented at rental.

Rotary honors top cops, firefighter, medic

BY TONY BRUSCATO
STAFF WRITER

As part of the Western Wayne Strategic Operations Team, Plymouth police Sgt Ron Bianchi is trained to handle some of the most serious emergencies assigned to the county-wide SWAT team.

That experience became necessary on Sunday, July 24, when a gunman barricaded himself inside a home at Joy and Haggerty roads in Canton Township.

During the Rotary Club of Plymouth's annual Public Service Awards presentation, Plymouth Police Chief Wayne Carroll detailed Bianchi's role in subduing the gunman, before naming the 16-year veteran the club's Plymouth Police Officer of the Year.

Carroll said when the SWAT team was activated, Bianchi was one of the first on the scene and immediately assumed the role of lead negotiator in attempting to disarm the gunman.

"Contact was made with one of the hostages inside the apartment, who was able to confirm that the suspect was armed," said Carroll. "Sgt Bianchi was able to get the suspect on the phone and began his dialogue."

Bianchi used his 14-years of experience to create a bond with the gunman, talking about their youth, families and common life experiences.

Before the perimeter was sealed, the gunman was able to flee the scene. However, it

wasn't to be the last time Bianchi would come into contact with the gunman.

The suspect was stopped by patrol units at I-275 and Ecorse Road, shutting down the freeway for a number of hours. The gunman got out of the car and put a gun to his head while 30 officers had their weapons trained on him.

"Sgt Bianchi took up a position behind the vehicle and began a face-to-face negotiation with the suspect," said Carroll. "He was able to convince the suspect that he was the voice on the phone and was able to convince the suspect to give himself up."

Tearfully, the suspect surrendered by throwing his gun to the pavement, he said. "He was taken into custody without any further incident."

After accepting the award, Bianchi said it's the most critical incident he's faced during his tenure as a hostage negotiator.

"We train every month, and gets to the point when you go on auto pilot," said Bianchi. "It just becomes second nature."

The Rotary Club gives out four annual awards to honor Plymouth and Plymouth Township police officers, a Plymouth Community Fire Department firefighter and a Huron Valley Ambulance paramedic.

"We all work hard at what we do, but unlike us, each of these people in these professions potentially puts themselves in harms way," said John Warner, co-chairman of the

Public Service Committee. "To perform our work, we don't have to potentially go into a burning building, drive a vehicle through traffic at an incredibly high rate of speed, discharge our weapon or dodge a bullet. We don't really worry that much that we'll be home for dinner."

TOWNSHIP OFFICER

In giving out the Plymouth Township Police Officer of the Year award, Chief Tom Tiderington noted in the past the award focused on one incident or spectacular arrest.

What we often overlook are the things the officers do each and every day, sometimes referred to as another routine day," said Tiderington. "But, these routine things officers do is what makes our community one of the safest and most enjoyable places to live in the country."

In giving the award, Tiderington said five-year veteran Dan Kudra represented the entire department in those day-to-day deeds performed by officers.

Patrolling the streets, handling traffic accidents, responding to domestic disputes and trying to find elderly people who have walked away from the assisted living home at three in the morning, said Tiderington.

"From my perspective, those are the things that improve the quality of life in a community."

Kudra said when an officer is on the road, no situation can

be taken for granted.

"Sometimes we're dispatched to a noise complaint, and when we get there and it's a knock-down, drag-out domestic incident, Kudra said. "I know that my partners and my fellow officers in the city of Plymouth will all be there to take care of me."

TOP FIREFIGHTER

The 2005 Firefighter of the Year award went to Christopher Mack, a 10-year veteran of the Plymouth Community Fire Department.

In his nomination, Fire Chief Randy Maycock said Mack takes care of the "behind the scenes" work to keep the department running smoothly.

"Chris is in charge of ordering our medical supplies and keeping our rescues well stocked, ready to respond to emergencies within the Plymouth community," Maycock said.

"This is important because each firefighter/paramedic needs to know when they reach for something during a medical emergency, the supplies are going to be there."

"Chris is also in charge of vehicle maintenance for the department," added Maycock. "Maintenance is vital because personnel need to be able to respond to emergencies in a safe and rapid manner."

"Both of these assignments require a commitment of extra time and effort, which Chris had readily chosen to take on," he said.



BILL BRESLER | STAFF PHOTOGRAPHER

Plymouth Township police officer Dan Kudra, paramedic Liz Scoggins, Plymouth Community Firefighter Christopher Mack and Plymouth officer Ron Bianchi were honored by the Rotary Club of Plymouth.

TOP PARAMEDIC

In naming the Paramedic of the Year, Paul Hood, the vice president for eastern operations for Huron Valley Ambulance, again used day-to-day criteria in handing Liz Scoggins of Plymouth this year's Rotary award.

"Liz takes challenges head on, and is not afraid to go above and beyond the call of duty," said Hood. "She has excellent paramedic skills, excellent bedside manner and always puts the needs of patients before her own. She not only takes care of the patients, but spends the extra time and makes the extra effort to keep the patient's family informed of what she is doing and why."

Scoggins, the daughter of former Plymouth police chief Bob Scoggins, said her goal is to remain calm in each and every situation where she's dispatched.

"If you seem excited, then the patients will get excited," said Scoggins, who has been an HVA paramedic for five years.

"As long as I remain calm, everyone seems to know things will be taken care of as best as they can be."

"I like being out there, just knowing that I'm out there helping people, knowing that I'm making them feel better during a stressful time," said Scoggins.

tbruscato@hometownlife.com
(734) 459 2700

NETWORK

FROM PAGE A1

versatility of the tool. "We put it out right away through the program," Carroll said. "We got some calls, but we just happened to find out who he was."

ACIM is a non-profit organization which relies on some state and federal funding, voluntary donations from law enforcement agencies, corporate sponsorships, private

donations and other fund-raisers.

It was founded in 1997 by Florida publisher Sherry Friedlander to assist law enforcement in the search/early recovery of missing children, the elderly, college students and the disabled. At the time, Friedlander said, no one in the country was offering a free service to law enforcement and it was needed. That's when Friedlander decided to take it on as a mission to "help save the lives of loved ones who couldn't help

themselves. She said ACIM has a physical presence in 35 states, but the service is available to law enforcement agencies nationwide.

The reason it takes so long to get it known is we don't have the extensive funding other programs have had, said Friedlander, who pointed out some 476 Michigan police departments and 83 sheriff's offices have access to the system. It's been very successful.

Law enforcement agencies can use ACIM in concert with

the Amber Alert system, but the ACIM can also be used in other situations, like it was in Plymouth.

According to Plymouth Township Police Chief Tom Tiderington, that's what makes it a valuable service.

While township police, who only recently joined the system, haven't yet had a reason

to use it, Tiderington said there have been cases in recent years where elderly people have wandered away from their homes and ACIM would have come in handy.

"When someone is missing the first couple of hours are critical, and this is a way to make people aware immediately," said Tiderington, who

came to Plymouth Township from Florida.

"When we heard about it, we decided it was definitely something we wanted to be part of. It's another tool we can use to make the community safe."

bkadrich@hometownlife.com
(734) 459 2700

BIKER BOB'S

ALL MOTORCYCLES BELOW MSRP & USED BIKES AT DEALER COST!

- WE'LL MEET OR BEAT ANY DEAL AND WON'T BE UNDERSOLD ON ANY IN-STOCK MOTORCYCLE.
- #1 in Customer Satisfaction in southeast Michigan
- Buy Now - Pay Later! No payments until Spring with approved credit.

**BEST Selection
BEST Buying Experience,
BEST Price!**

BIKER BOB'S HARLEY-DAVIDSON

14100 TELEGRAPH TAYLOR, MICHIGAN 48180
734-947-4647
WWW.BIKERBOBSHD.COM
1-866-GET-A-HOG

1-94 TELEGRAPH 1-75
NORTHLINE EUREKA

Joe's Finest Selections!

<p>California Romaine Hearts 2/\$4.00</p> <p>Grape Tomatoes 2/\$3.00</p> <p>Beringer White Zinfandel \$4.99 750 ml</p> <p>Amy's Organic Soups \$1.99 14.1 oz. can</p>	<p>Broccoli Crowns 99¢ lb.</p> <p>Spanish Seedless Clementines \$5.99 5 lb. Box</p> <p>Muenster Cheese \$2.49 lb.</p> <p>Bright, Colorful Flowering Poinsettias 4" - \$4.99 ea. 1m - \$7.99 ea. 2m - \$14.99 ea.</p>	<p>Burgess 2001 Lake County Syrah \$10.99 750 ml <i>Deep Dark and Delicious!</i></p> <p>Washington Fuji Apples 79¢ lb.</p> <p>Washington Gala Apples 79¢ lb.</p> <p>Beringer White Merlot \$4.99 750 ml</p> <p>Haagen-Daz Ice Cream 2/\$5.00 Pint Size</p>
---	--	---

Byrds Choice Meats!
Order Your Holiday Favorites!

- Choice Standing Rib Roast
- Racks of Lamb
- Fresh Bell & Evans Turkeys
- Seafood & Deli Trays
- Crown Pork Roast
- Dearborn Spiral Glazed Hams
- Homemade Smoked Kielbasa

- See Ya Soon!

Fruit Baskets - A Great Gift Idea!.....
A Variety of sizes \$19.99 & up Filled with fresh fruit, candy, cookies, jam, sausage, mustard, crackers and cheese. Add a bottle of wine! Order today for the Holiday! Prices Good Through DEC. 4, 2005

Joe's Produce
33152 W. Seven Mile • Livonia, MI 48152
www.joesproduce.com (248) 477-4333

Free yourself from big phone bills.

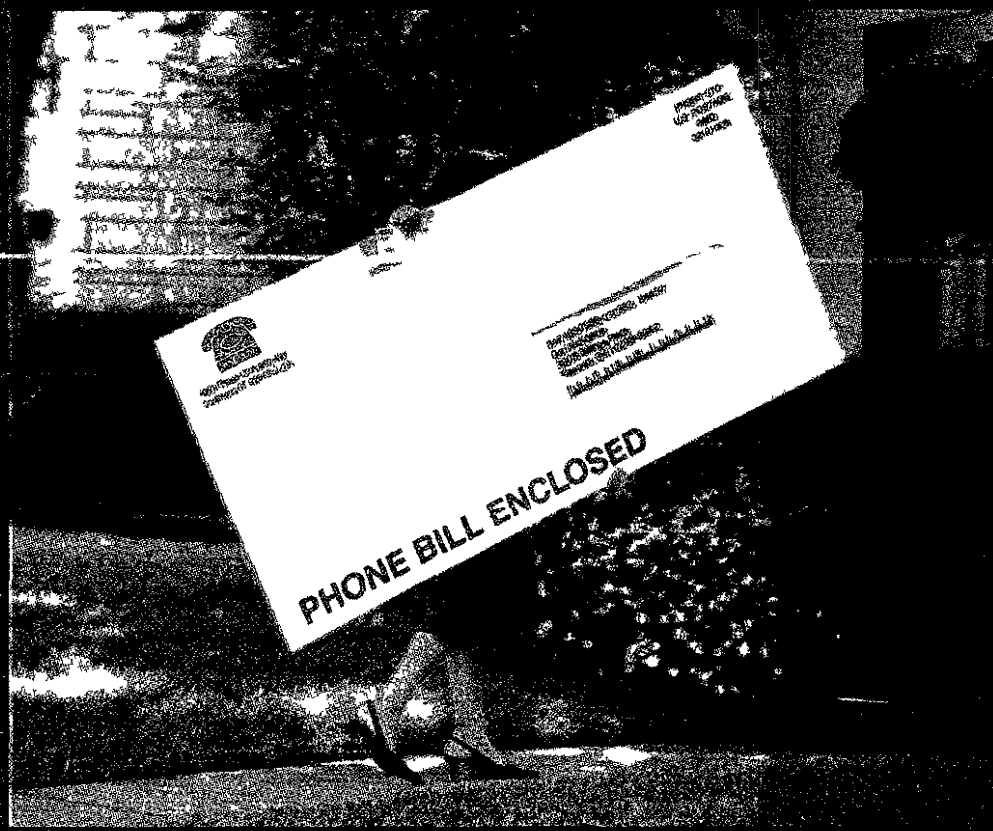

More advanced phone service for less money. That's Comcast!

Switch to Comcast risk-free, and save more than 25% over SBC. That's just \$39.95 a month for unlimited local and long-distance calling! You also get the 12 popular calling features you expect plus cool new features you'll love.

Unlimited local & long distance
 12 popular calling features plus Voice Mail
 Satisfaction guarantee*
 Keep your current number
 One bill for all your Comcast services
 Check Voice Mail online

Comcast Digital Voice™ with unlimited local and long distance
\$39.95 per month
25% compared to SBC's Unlimited Package, you'll save more than

Switch risk-free 1-888-COMCAST comcast.com



Goodfellows need help with annual fund-raiser for holiday toys, gifts

BY JULIE BROWN
STAFF WRITER

Barb Volante and others from the Plymouth Goodfellows are hoping you'll be generous when they sell their newspapers this Saturday.

"We're going to be scattered throughout the city, the township and Old Village," said township resident Volante, president of the Plymouth Goodfellows for three years. There's increased demand this year due to a poor economy.

Last year, Plymouth Goodfellows gave toys and gifts to 134 kids and fed 208 people. As of last Monday, the list had 162 kids and nearly 260 to feed. The Goodfellows need to raise a minimum of \$34,000 Saturday.

"The numbers have grown every year since I have been president," she said, citing both growing need and greater outreach efforts.

The Goodfellows will sell the special edition newspaper 10 a.m. to 2 p.m. Saturday, Dec. 3, on sidewalks, in front of grocery stores, "you name it." She has about 35-40 volunteers and welcomes more, to volunteer, call Volante at (734) 207-0619. Volunteers should be high school age or older.

Goodfellows haven't been at intersections for the past several years, due to safety concerns. The newspaper edition has been mailed to homes and businesses in the 48170 ZIP code.

"It's a really good organization," said Volante, who likes the short-term commitment. "That makes it very, very nice."

She and other Goodfellows work closely with the Plymouth-Canton schools, United Way, Salvation Army and others to guarantee no child is without a Christmas. Only Plymouth and Plymouth Township residents are helped, and purchases are made at local merchants, Plymouth Kmart and Kroger.

"It goes back to the Plymouth residents," Volante said. "Everybody in Plymouth wins." The Plymouth Goodfellows now have 501 (c)(3)



The Plymouth Goodfellows will be out in force for their annual newspaper drive Saturday, with 162 children and nearly 260 people on their list for gifts and food.

nonprofit status, making them eligible for employer matches.

She has found some people are surprised there are needy residents in the community. "People say 'Needy people in Plymouth, what are you talking about?'" Those helped come from all walks of life, such as those who've experienced a recent death or serious illness. One father had been sent to Iraq with the military, and those helped aren't just low-income.

"We had people for lots and lots of different reasons," she said. "We help out for many, many reasons. We're not here to judge."

In the past, Goodfellows have shopped for food and gifts and delivered them, but this year's plan is different. Each child/student will receive a Kmart voucher and parents can replace items on wish lists that aren't available. Taking the kids shopping helps parents feel better, Volante said, adding men have found it particularly difficult to take assistance.

There will be Kroger certificates for food, \$35 per person up to \$210 for a family. "Again it brings it back to that element of pride and dignity," she said of the shopping.

Bill Moritz, social worker for the Salvation Army Plymouth Corps, is glad for the help of the Plymouth and Canton Goodfellows at Christmas.

"We share each other's lists" to avoid duplication, he said. "We want to make sure everybody gets help." Goodfellows have given toys and food to the Salvation Army for holiday distribution.

~Now Open~

Fringe Salon

& Barber Shop

Full Service Salon featuring
 Color • Highlights • Perms • Straightening
 Complete Nail Service • Waxing

FREE L'Oréal Serie
 Conditioning Treatment
 with Service • \$15.00 Value

New Clients
 10% Off Services
 with this ad

19227 Newburgh Road • Livonia (734) 591-6561

LOREAL REDKEN MATRIX CREW PAUL MITCHELL SEBASTIAN SEMI DI LINO

Never too early to start saving.

USA Credit Union has great savings plans for the whole family.

12-month Flex Savings Certificate

4.06%

APY Only \$100 to open!

For you We are offering a 12-month Flex Savings Certificate that gives Members options and benefits not found anywhere else.

- Once during the 12-month term you can **increase the rate** to the current rate without changing the maturity date.
- Once during the term you can **withdraw up to 25%** of the principal with no penalty.

Make **as many deposits as you like**, with a minimum of \$10 and a maximum of \$25,000 per day.

For the kids Two savings programs to teach them to handle their money responsibly and to reward good savings habits. Each club offers a free gift, a newsletter and online educational programs.

Planet M Club
For Members between the ages of 5 and 12.

Club USA Boom
For older Members ages 13-17.

Visit us online at www.usacuoonline.org



Auburn Hills 248 322 9800 ext 3205 Plymouth 734 453 5440 Troy 248 528 0302

Rate at time of printing and subject to change



0208390580

Animal Planet's reluctant 'stars' to visit pet store

BY CAROL MARSHALL
STAFF WRITER

It wasn't too long ago that Mark Ramos was "the dog catcher." As an investigator for the Michigan Humane Society, for nine years, he's gone out the streets of the Detroit area to look into hundreds of animal abuse cases every year. But Ramos has for the past three years enjoyed - and been baffled by - celebrity status, since he's become well-known to fans of The Animal Planet's *Animal Cops Detroit*.

Now, everywhere he goes, he's asked to sign autographs and talk about his experiences on the popular television show. Next weekend, he'll be on hand at a pet store in Canton to do just that.

"People tell me I'm a star, but I just don't believe that," Ramos said.

Ramos and his partner and co-star Debby MacDonald will talk about their recent visit to New Orleans as part of the Humane Society's annual rescue efforts after the Gulf Coast hurricanes.

For several weeks, the team joined the national and international relief efforts, search-



Michigan Humane Society investigator Mark Ramos and his partner and Debby MacDonald will talk about their recent visit to New Orleans as part of the Humane Society's annual rescue efforts after the Gulf Coast hurricanes during an appearance at Pet Supplies Plus in Canton.

ing the areas by foot and by boat, in the hope of rescuing lost, stray and injured animals. Distributing food and water, providing medical care and comfort to pets in temporary shelters, MacDonald, Ramos and the rest of the team managed to save hundreds of pets and reunite a large number with their human companions.

It's a fund raiser for the Michigan Humane Society, said Ted Linden, store manager at Pet Supplies Plus in Canton. "People are really excited to hear that the Animal Cops are coming here."

Each year, the MHS Cruelty Investigation Department handles an average of 4,000 cruelty cases revolving around dog fighting, pets exposed to the elements and animal neglect in the cities of Detroit, Hamtramck and Highland Park. Working in collaboration with the Detroit Police, the

investigators track down the offenders and bring them to justice.

"We've really worked hard to cultivate that relationship with the police department," Ramos said. "What they've come to realize is that most of the time, if there is animal abuse going on, there is other crime going on. If someone is cruel to an animal, chances are he's also abusing a person in the house. Other kinds of abuse are also associated with other illegal activities like drugs."

This time of year, most of the abuse reports deal with animals left out in the elements. And even though the investigation unit responds to some 4,000 calls per year, only about 50 tickets per year are written.

"What we really focus on is education. A lot of people don't realize how dangerous it is to leave their animals out with no protection," Ramos said.

The Animal Cops will appear at the Canton Pet Supplies Plus store, located 43665 Ford Road, Dec. 10 from noon to 2 p.m. For more information, call the store at (734) 981-9191. For more information on the MHS, visit www.michigan-humane.org.

FOR THE RECORD

Mary Ann Bricker
Bricker 55 formerly of Bloomfield Township died Nov. 27

Nicholas R. Diana
Diana 24 died Nov. 25

Dorothy L. Lent
Lent 91 of Plymouth died Nov. 25

Nancy H. Morrison
Morrison of Birmingham died Nov. 26

Joseph L. O'Connor
O'Connor 82 of Ann Arbor died Nov. 23

Mary Ann Opalinski
Opalinski 83 died Nov. 21

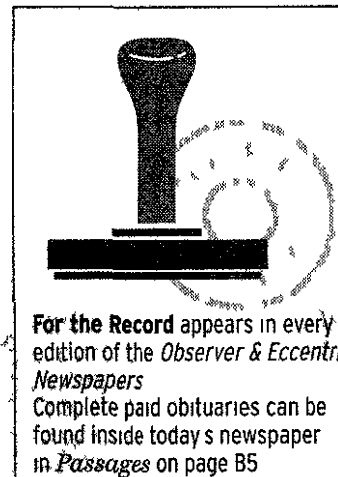

For the Record appears in every edition of the Observer & Eccentric Newspapers. Complete paid obituaries can be found inside today's newspaper in Passages on page B5.

Brent C. Verrot
Verrot 46 died Nov. 19

WEB SITE

FROM PAGE A1

based information.

"Our enhanced Web site is just one of the benefits of joining with the Gannett Company," said Richard Agiman, publisher of the O&E. "In addition to maintaining the most complete and comprehensive site of local news for the community, our readers, advertisers and just plain surfers can now easily link via our Web site to the resources of cars.com, careerbuilder.com and Homescape."

Find a job, place an ad, sell a car, read about what's happening in your hometown or search for a story you forgot to clip and save - it's all a computer click away. You can subscribe to the print edition or e-

mail a vacation pause online, too.

We have redesigned the Web site with our readers in mind. Find your hometown news by utilizing the navigation bar at the left hand side of the screen - it's fast and easy. And the local community links are on the home page. We have several photos online that have appeared in the paper and we will be publishing several more photos that were not seen in the paper. In addition, prep sports from throughout western Wayne and Oakland counties is presented on a special sports home page. Access local city guides, area obituaries and our popular Pick the Pros contest from the hometownlife.com site.

MORE TO COME

And more improvements are in the works, including

updates on local news and information on a daily basis, along with photo galleries for special community and sports events.

"In the coming months, we have a lot of plans for our new site. We will continue to enhance our online classified ads, our new Real Estate section, bring you more entertainment events with a Filter online calendar, bring the Pink fashion pages online and pro-

vide new and exciting forums for news and information," said Michael Mizner, director of information technology at the O&E.

We're excited about updating, improving and adding features to our site and we welcome your comments. Go to www.hometownlife.com and click on "Contact Us" to tell us what you think and what you'd like to see in 2006.

AN AMAZING WORLD OF TOYS

Save 10-40%
On 1000s of
Toys • Dolls • Activities

Over 30,000 Playthings • Convenient Parking • Free Gift Wrap • We Ship

Shop at Your Convenience!
REALLY GREAT TOYS

Ends 2/31/05. Over sized items excluded from wrap.

The Doll Hospital & Toy Soldier Shop
3947 W. 12 Mile, Berkley, 248-543-3115
M-W & Sa 10-5:30 Th & Fr 10-8:30 Su 12-5

THE WORLD'S MOST PERFECT BY THE DESIGNER

You found the perfect woman. We have her perfect holiday gift.

ORIN JEWELERS
OUR FINE DIAMOND STORE SINCE 1933

CERTIFIED GEMOLOGIST
REG. S. 1980 S.W. 10TH AVENUE
NORTHVILLE
101 East Main Street at Center
248 349 6940
GARDEN CITY
29317 Ford Road at Middlebelt
734 422 7030
www.orinjewelers.com

Subscribe today, call (866) 88-PAPER

Have You Heard About
the NEW IRISH SHOP
IN FERNDALE??
GREAT GIFT IDEAS

Jewelry, Clothing, Rugs, Crystal,
China, Pottery, Artwork,
and Food Items.

Come See what
Everyone is Talking
About...

The Twisted
Shamrock
276 W. 9 Mile Rd. Ferndale
(next to Buffalo Wild Wings)
(248) 544-4170

Lose Weight for Life!

St. Mary Mercy Bariatric Center
a Minimal Surgical Approach
to Treating Obesity

The NEW St. Mary Mercy Bariatric Center offers weight loss surgery performed laparoscopically resulting in minimal pain, less scarring, shorter hospitalization and recovery time. You can lose about 70 percent of excess body weight within the first year and maintain your weight loss. Gain control of your health and prolong your life.

WHY WEIGHT?
Learn more at one of our FREE educational seminars:
December 7 • 6:30 p.m.
St. Mary Mercy Hospital Auditorium
Meet Dr. Zeni and the Bariatrics Team
Call 734.655.2692 to register NOW!

Tallal Zeni, MD, Director
Minimally Invasive and Bariatric Surgery
St. Mary Mercy Bariatric Center

- Medical Staff member St. Mary Mercy Hospital Livonia MI
- Fellowship Evanston Northwestern Healthcare Chicago IL
- Experienced in advanced laparoscopic gastric bypass surgical techniques
- Team approach to treatment and care
- Specialty trained registered nurses, dietitians, behavioral specialists and exercise physiologists

Call 734.655.2692
or toll-free (800) 686-9940

St. Mary Mercy Bariatric Center • Marian Professional Bldg., Suite 311 • 14555 Levan Road • Livonia, MI
www.stmarymercy.org

Convenient office hours • Accepting new patients • Most insurances accepted

ST. MARY MERCY HOSPITAL
Great doctors and nurses. In your own backyard.

Is your fur too short, too tired,
too shapeless, or too boring?
IT'S NEVER BEEN WORTH MORE!

The Great
"Trade It In"
Sale

Bring in any old fur
and receive a very generous
Trade-In Allowance
toward a beautiful new
Dittrich Fur!

Dittrich
Since 1899

Detroit • (313) 873 8300
Bloomfield Hills • (248) 642 3000
www.dittrichfurs.com

O & D Bush Jewelers, Inc.

GOING OUT OF BUSINESS

CLOSING FOREVER... EVERYTHING MUST BE SOLD even furniture and fixtures!

SAVE UP TO **70% OFF**

TAKE AN ADDITIONAL 10% OFF

ONE WEEK ONLY Valid Thru 12-03-05

ONE WEEK ONLY Valid Thru 12-03-05

THE ALREADY DRASTICALLY REDUCED SALE PRICES

O & D Bush Jewelers, Inc.
509 West Ann Arbor Trail • Plymouth, MI 48170
MONDAY THRU FRIDAY 10 00 AM - 6 00 PM • SATURDAY 10 00 AM - 4 00 PM • CLOSED SUNDAY

Come In & register for a
FREE GIVEAWAY

Name _____
Address _____
Phone _____

OUR VIEWS

Chiefs, fans winners in loss

The Canton Chiefs fell one step short of football history Saturday, dropping a 31-21 decision to Rockford in the Division 1 state championship game at Ford Field in downtown Detroit.

But, if you'll pardon our use of the cliché, that doesn't mean they aren't winners. The Chiefs — and their legions of fans — proved to be exactly that.

The Chiefs fought off adversity all year. They lost two tough games — to Livonia Franklin, which went unbeaten in the regular season, and to Walled Lake Western when they didn't have quarterback Shawn Little.

They had to earn every victory on the road to Ford Field, including coming back from a 14-0 deficit in the regional final against Macomb Dakota, then dominating Dakota in the second half to earn a spot in their first title game.

Against Rockford, the defending Division 1 champion, it would have been perfectly normal for the Chiefs, none of whom had risen to this level in the playoffs before, to come out a bit awed by their surroundings and intimidated by the more-experienced Rams.

It didn't happen. The Chiefs, led by the calm Little and the exciting Deshon McClendon — and reflecting the style of coach Tim Baechler — actually grabbed a 14-7 lead with a little over five minutes left in the first half. In the end, they simply couldn't stop the Rams, who made the big plays when they absolutely had to have them, as championship teams do.

But there they were, fighting until the final whistle, backed by the effort instilled by their coach and the support they drew from their fans, who numbered in the thousands to make the trip down I-96 to watch their beloved Chiefs.

A proud, boisterous cheering section can often be a "12th man" on the football field, and Canton fans were exactly that Saturday. In the week leading up to the title game, there were signs and messages at various places around town, urging the Chiefs to give it their best.

And then the fans went out and did the same thing. The student section — hundreds of youngsters devoted to the concept of team spirit — were asked to sit down so the people around them could see. Rather than give up the proud tradition of standing and cheering throughout, the kids showed class by simply moving down to the end zone seating, where they could cheer unencumbered by the idea of spoiling the game for anyone.

Yes, the Chiefs lost in their first shot at a state championship, but one gets the feeling Baechler will get them another chance. And on this November Saturday the Chiefs — and their fans — showed they've earned it.

We need to confront our racial problems

We live in the most racially segregated metropolitan area in the United States. In 2001, the US Census confirmed what we already knew. Though many middle-class African-Americans have moved into the suburbs, the suburbs remain predominantly white and Detroit remains predominantly black.

The city of Detroit is also poor and aging. Despite some high-profile developments such as Fox Center and Compuware, Detroit seems resistant to the renaissance that has been the city's theme for a generation. Instead, population has declined steeply, unemployment has remained stubbornly high, more people live in poverty in Detroit than in any other large city in America, school children continue to underperform suburban children by a wide gap and the tension between city and suburbs seems as taut and dangerous as it has ever been.

In the wake of several racially charged incidents and statements, many area leaders have called for a "racial summit." While we endorse the idea of a meeting on race issues among the leaders of the metro area, we believe that is only one of many steps that need to be taken in what will be a slow process of coming to terms with our racial and economic differences.

Meetings among area leaders are important, but programs that bring people from all walks of life and all age groups together will do more to break down the barriers that have built up over generations.

We are living with the consequences of our history. We need to understand that history, learn from it and break down the walls that have separated us for too long.

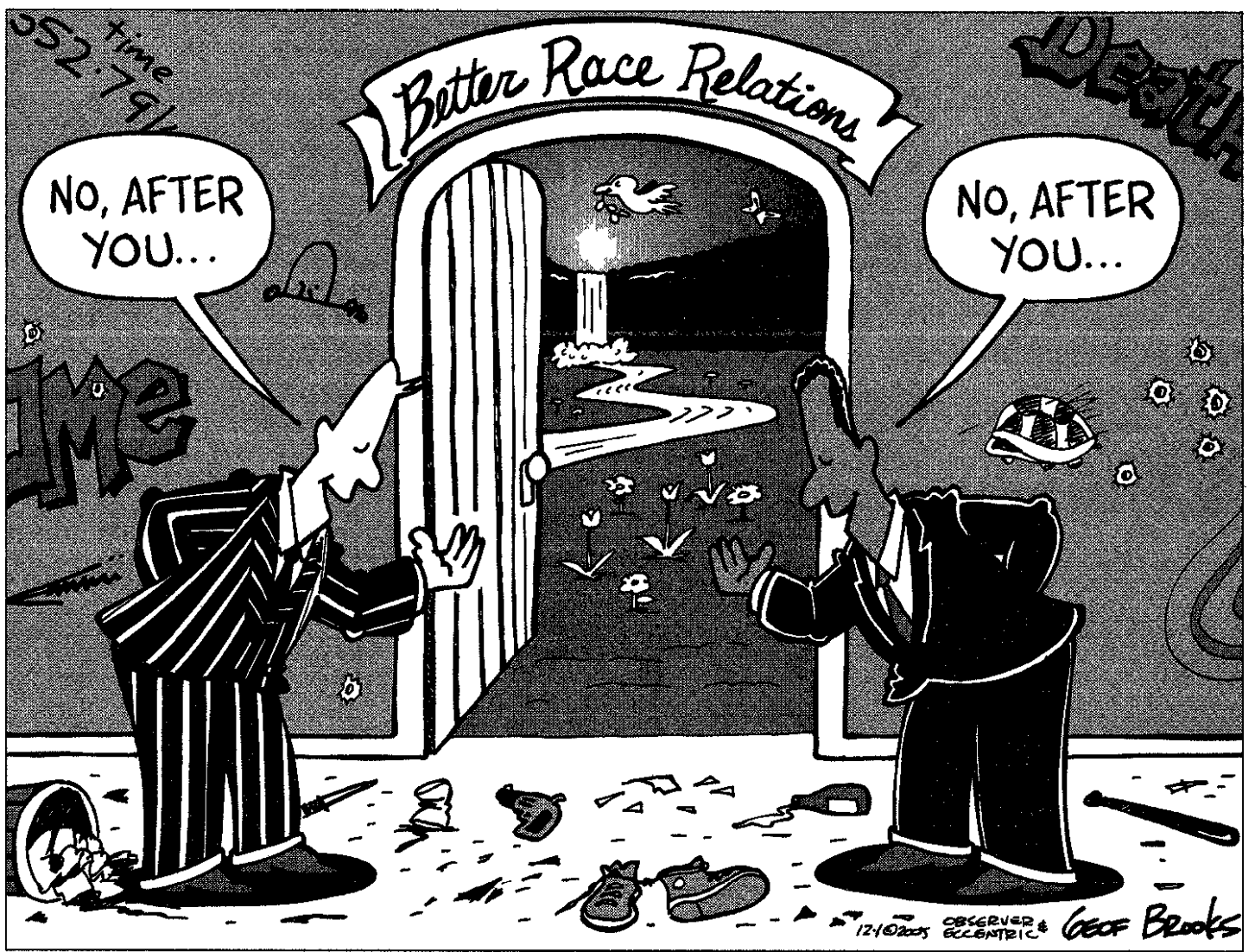

LETTERS

Thanks, vets

A big "thank you" to all the veterans who came to the pancake breakfast on Veterans Day at the American Legion Beasley-Zalesny Post 112 in Plymouth. Sixty-plus of you enjoyed pancakes, sausage, juice and coffee. But most of all, you enjoyed talking with each other. There were many stories told. Some sad, some happy, but good stories that needed to be told.

Thanks also to all of the Legion and Auxiliary members who worked so hard to make this first-time event a success. I am sure this will now become a regular event for our Post.

Following the breakfast, many of you accompanied the Legion and Auxiliary to the rock 'n' roll to join with the many community members who came out for the annual Veterans Day service. This service is always held at the 11th hour, on the 11th day of the 11th month. The American Legion Posts 112 and 391, the VFW Post 1426 and the Vietnam Veterans Chapter 528, all of Plymouth, participated in this event.

After several wonderful tributes to veterans, we all sang a rousing rendition of *God Bless America*, led by state Rep John Stewart.

Jeanette Burman
American Legion Auxiliary Unit 112

Thank you, Chiefs

On behalf of the Plymouth-Canton Community Schools Board of Education, I want to thank the Canton High School football team for their remarkable run to the state championship game last Saturday afternoon at Ford Field. Although you did not achieve the results you had hoped for, you represented yourselves, your team and high school incredibly well. We are extremely proud of you.

However, more than playing in a championship game, you brought the best out of our Plymouth-Canton Educational Park and the entire community. Players from Plymouth and Salem High Schools, their parents and fans supported this Canton team, its coaches, athletic director and parents. It was a wonderful display of sportsmanship and community.

As the superintendent of schools, I left the game with a great feeling of pride. Seeing that "sea of red" of support running from end zone to end zone only reinforced my belief in this school district and the communities that form our boundaries. For this special day, this was "our team" and everyone who supported the Chiefs left them with a memory they or we will never forget.

Thank you to the team and the fans for a job very well done. I am proud to be the superintendent of the Plymouth-Canton Community School district.

Jim Ryan
superintendent of schools

Why donate?

I read your article re Santa pictures with pets in Kellogg Park. I love being a Plymouth resident, as it seems like there are so many community happenings.

I am very disturbed by the fact that the Michigan Humane Society can come in to our community to collect donations. Although I believe the Humane Society does do wonderful things for our homeless animals, I wonder if the residents of Plymouth and Northville realize the Westland shelter will not assist these residents with stray pets, as they say they do not have a contract with Plymouth and Northville.

Why take our donations then? I think the Westland shelter needs to assist ALL communities so that we may ALL work together for the GOOD of the strays.

Pam Comben
Plymouth Township

Culture of learning

Last week it was my privilege to be a co-keynote speaker with former astronaut and U.S. Sen. John Glenn at the Midwest Higher Education Conference held at Ohio State University. Sen. Glenn agreed with me that higher education is the essence of recovery for our economy.

The Michigan Higher Education Commission has provided a study that for every \$1 we invest in higher education, there is a \$26 return to our economy.

The Michigan Legislature has implemented a new funding formula for higher education which will lead to training more engineers, doctors, nurses and health care workers. We have shifted \$91 million more into the higher education budget and every university will receive more funding from the state of Michigan this year than last year.

Universities have proven to be job-generators. There is no mystery why Toyota has chosen to locate 700 new research and development jobs in Michigan — directly south of Ann Arbor and close to our major universities.

Science and engineering degrees represent 60 percent of all bachelor's degrees earned in China and only 31 percent in the U.S. Now, the "flattening of the world" means that foreign-born engineers and scientists can stay in their native land and do world-class work from their home country.

We need to create a new culture of learning for Michigan's children.

In Michigan, 84 percent of new jobs are coming from the small business sector, so efforts to lower taxes must focus on small business.

Ohio has recently eliminated its personal property tax on businesses and Michigan needs to significantly cut personal property taxes and remove the cost of health care benefits from taxable base of employers.

Yes, higher education is the essence of recovery for our economy.

John C. Stewart
state representative District 20
chairman Higher Education Appropriation

Winning the day

The latest reports from Iraq strongly support the evidence that the freedom fighters in Iraq are winning the war and winning big. The Iraqis have long believed that the ouster of Saddam was long overdue, that the subsequent battles to free the people in the cities and on the farms was necessary to achieve a democratic eastern state.

The Iraqis have more electricity than they ever have had, with the old schools refurbished and many new ones constructed. Not incidentally, women may now attend the schools and run for political office.

The big election is scheduled for Dec 15. Feel proud. We have helped to turn the world situation to greater people participation in government, with a greater voice in the state's production of goods and services.

Many in our land have cried for the pullout of U.S. troops for months, the lack of support noticed on the many TVs available to both the free Iraqis and the insurgents. Count many of the deaths of our servicemen and women as victims of the war because too many among us have called for an abrupt end to our presence in Iraq, the lack of support noticed by the insurgents watching the dissent on the tube every day.

One big mistake concerning the invasion of Iraq and the capture of Hussein can be suggested. We began our assault on terrorism several years late. In 1993, we had already had several notices that the terrorists would promote the killing of all Jews, Christians, children — a very special target in the all-out assault.

It was time two years ago to right the wrong in our world. Patience. Other regimes seem to want to play the game of terror. We are now attending to the threats posed by Iran and North Korea. We must prevail. We must survive. Our nation promoting free market operations, free enterprise, with a limited government, can win the day for all.

Neil Goodbred
Livonia

SHARE YOUR OPINIONS

We welcome your letters to the editor. Please include your name, address and phone number for verification. We ask that your letters be 400 words or less. We may edit for clarity, space and content.

Mail
Letters to the editor
Plymouth Observer
794 South Main
Plymouth MI 48170

Fax
(734) 459-4224

E-mail
bkadrich@hometownlife.com

QUOTABLE

"What it shows is that we're willing to take an agreement that's been in place for 10 years, make some modifications, and try to go forward for an additional five years... I think it's something we can look at, probably even make a counter proposal that could be acceptable to both parties."

— Richard Reaume, Plymouth Township supervisor, on the proposal from city officials for continuing the joint fire agreement.



PUBLISHED THURSDAY AND SUNDAY



Brad Kadrich
Community Editor

Marty Carry
Advertising Director

Hugh Gallagher
Managing Editor

Peter Neill
General Manager

Susan Rosiek
Executive Editor

Richard Aginian
President/Publisher

Our fundamental purposes are to enhance the lives of our readers, nurture the hometowns we serve and contribute to the business success of our customers.

It's time for state's leaders to pass tougher school standards

At a time of economic crisis, it's simply astonishing that Michigan's political system is so out of touch and broken.

It's out of touch because those who are supposed to represent us in Lansing are single-mindedly preoccupied with tactical eye-gouging, prior to next year's statewide elections. Meanwhile, most people in Michigan are worried about their next year's paycheck and if there will be one at all.

Our system is broken because most folks in Lansing are behaving as though sanctimonious posturing and "gotcha" press releases are the way to fix Michigan's economy for the decade ahead.



Phil Power

Can it be fixed? We'll find that out over the next few months as Lansing considers a far-seeing and sensible set of proposals for a new school curriculum from state Supt of Instruction Mike Flanagan. He wants all schools to require four years of math, including Algebra I and II, four years of science, including chemistry, and three years of social science, including a semester of economics.

What a happy shock! Somebody actually has the guts to propose something tough, far-reaching and relevant to our problems!

His proposal is way overdue common sense. Up to now, Michigan has led (or trailed, depending on how you look at it) the nation. The only thing we've required has been civics. We've got this problem in Michigan that we think that "work-ready" means "high school dropout work-ready." "This is a recipe for disaster," Flanagan told me last week. "Today, only one-third of our school districts require Algebra I, only 10 percent Algebra II. Yet that's exactly the skill level that is required today to work in a modern auto plant."

Much of Flanagan's thinking builds on last year's Cherry Commission report. The commission (of which I was a member) found that fewer than a quarter of Michigan's high school graduates take the courses necessary to prepare them for college and that half of those who enroll in college drop out.

That means that less than 20 percent of today's high school freshmen will ever graduate from college. And that, in turn, is a prescription to make Michigan into an economic Mississippi, which long was the weakest state in terms of income and educational attainment. The cute term, of course, is "Mississippi."

So I asked Flanagan what chance his radical proposal has in the quagmire of Lansing. "Pretty good," he replied, sounding hopeful. "Most of the big players seem to be onboard. My biggest concern is a kind of whispering campaign going on that all our kids really are

not up to taking demanding courses. This is simply demeaning to our kids."

"The Japanese expect all their kids to take tough courses, and I don't think our kids are dumber than the Japanese."

Word is that the state Board of Education will approve the proposal in a couple of weeks, which puts the issue squarely in the well-fed lap of the Legislature (one of the nation's highest paid) and the various interest groups.

That's where the going gets tough. There are so many things that can go wrong before next March, which is when curriculum reform has to be adopted to take effect in the fall.

First, there is the education establishment — never a force for far-reaching change — that is already hedging its bets.

The Michigan Association of School Boards is opposed to any move that would require districts to do anything. "We support guidelines, we oppose mandates," says an MASA spokesperson. The Michigan Association of School Administrators, while generally supportive, is worried about issues of local control. A spokesman for The Michigan Association of Public School Academies (i.e. charter schools) says his members are already doing what Flanagan wants.

Forget the educators. You can bet things will get much worse once the proposal gets to the Legislature. Take Rep. Brian Palmer, R-Romeo, chair of the House Education Committee, as an example. He's worried about loss of local control — a mysteriously persistent doctrine that ignores the fact that Proposal A put money (and control) for the schools in the hands of the state in 1994.

All the districts are concerned about loss of local control. We can't let that happen," Palmer says. Opposition from parts of the education establishment will also play to the legislative knee-jerk reflex to do nothing.

"We should not have anybody in the education establishment disagree with what we're doing here," intones Palmer. Yes, the establishment has done a great job ensuring quality in districts like Detroit.

It's crunch time, folks. The political system can step up and actually do something serious and constructive about saving our state's economy, long term, by adopting the tough curriculum Flanagan is proposing. Or the system can do what it's done so often in the past: fudge, dodge, delay and finger-point.

We'll see. But if you have a stake in this state's future, or kids in the public schools, you might not want to be too passive about it.

Phil Power is a longtime observer of politics, economics and education issues in Michigan and a member of the Cherry Commission on Education. He would be pleased to hear from readers at ppower@hcnnet.com.

Bond plan too expensive when Powell property is an option

The Plymouth-Canton school board is preparing to ask voters to approve a bond initiative in early 2006, including \$13 million to add to the existing elementary schools to cover "equity and growth."

What is this equity issue? According to Dr. Ryan, the district needs to add several new gymnasiums onto some of the schools that currently only have a combination gym/lunchroom for "equity" reasons.

What is this growth issue? According to Dr. Ryan, the district needs to add 28 new classrooms onto existing 50-year-old schools in order to plan for "future" growth.



Nancy Conzelman

What the board and Dr. Ryan are not telling you is the real reason. The extreme overcrowding problem that exists now at the elementary level. This situation will not be alleviated when Cherry Hill Village school opens in 2006.

But why wouldn't Dr. Ryan just come right out and say that the schools are desperately overcrowded instead of hiding behind words like "growth" and "equity"? He doesn't want anyone to question not seeking to build a new school on property the district already owns at Powell and Ridge roads.

Dr. Ryan knows he can't very well sell that land and then turn around and ask voters to support a bond to buy additional land for another school. So his job over the coming months is to convince voters adding to existing schools is the right decision, knowing full well that it would be much more expensive, more disruptive and worse for the district.

It was just this past summer that Dr. Ryan stated Plymouth-Canton is at least two schools behind where it should be at the elementary school level. So now, he is going to sell the Powell/Ridge property and permanently eliminate any chance for there ever to be a school built to serve northwest Canton Township, western Plymouth Township and Salem Township.

But, you may ask, isn't a good deal of future growth in our school district coming from southwest Canton? Yes, and the last two schools in the district were built in southwest Canton as a result. But the severe overcrowding has been chronic in the older schools, especially those serving northwest Canton Township, western Plymouth Township and Salem Township, and will continue to be if the district's own population numbers are correct.

Dr. Ryan has said no new school is needed at the Powell/Ridge site, yet he is proposing to add more than the equivalent number of classrooms and at least three gyms to the schools that house the students from northwest Canton Township, western Plymouth Township and Salem Township.

How did we get to the point where our schools are so overcrowded? It has been 14 years since

the district made the "temporary" decision to convert the art and music rooms into general education classrooms. This was done to reduce class sizes.

If art or music ends up in a suitable classroom in a particular building today, it is purely by happenstance. Most often those classes are taught on a cart, or in a hallway. Portables have been added all over the district, including at the newest schools. The average school with no dedicated art and music rooms and two portables has, at a minimum, 120 children over the designed capacity of the school.

But the impact of this is more than just crowded classrooms, extra lunch periods must be added, which reduces the number/length of gym classes that can be scheduled. Packing kids into schools designed for much smaller populations strains other resources such as the library and playground space. Dr. Ryan knows all of this, but nevertheless continues to couch his rationale for added gyms and classrooms in terms of "equity" and "growth."

Dr. Ryan's plan, however, is ill-conceived. The architects that, in 2003, studied some of the very same schools now being targeted for expansion concluded it was not advisable or even feasible to add on to these buildings. Moreover, these additions will take years longer to complete than building a new school, subjecting the district to many additional years of overcrowding. With the land already owned by the school district, it would be far cheaper, faster and infinitely smarter to build a new school.

Despite all of this, Dr. Ryan has convinced the board expansion is the best plan and he did so without calling the existing situation for what it is: severe overcrowding. Instead, he must hide behind words like "growth" and "equity" so he can get his hands on the pot of money sitting at the corner of Powell and Ridge roads, knowing the extra dollars for his more-expensive plan will come out of taxpayers' pockets.

The use of such euphemisms has the added benefit of giving him a lot of wiggle room if he has to cut something (which he has already begun to do). After all, if you don't admit there is a problem, no one can accuse you of failing to do something about it.

The board has bought into this approach. Of course, this is the same board that chose to do absolutely nothing when its own committee tried to manage the overcrowding at Bird (the smallest school in the district that now houses the largest number of students). This is also the same board that for years has allowed the art and music programs to deteriorate.

We as voters, however, do not have to buy into it. If this bond passes without a new elementary school in the plan, then the district's fate will be sealed for decades to come, and the only available land for a new school in the western district will be gone forever.

Nancy Conzelman is a Plymouth Township resident.

BRIGHT, EAGER, AND STILL A POOR STUDENT



Your child may have 20/20 eyesight but 0/0 vision—the difference is critical. Eyesight is merely the basic ability to see; vision is the ability to identify, interpret, comprehend and act on what is seen.

Routine vision tests performed by school personnel or by most eye care professional measure eyesight. They do not include the kinds of testing that can find visually related learning problems.

COULD YOUR CHILD BE AT RISK?

- Has trouble comprehending
- Avoids reading or other up close tasks
- Omit, turn around, or confuse letters/words
- Easily distracted
- Short attention span
- Squint, frown, or rub eyes
- Frustrated when doing homework
- Poor handwriting



Perhaps you know a very bright child who never works up to their potential. Different methods have been tried, even extra tutoring, but they still fall behind. Meanwhile, that bright child is becoming more frustrated, losing self esteem and may already be feeling a sense of FAILURE. Chances are they may have a vision related learning difficulty.

Please Join us For Our Free Lecture: **The Visual Connection**
Speaker: John P. Jacobi O.D., F.C.O.V.D
Developmental Optometrist

Tuesday, December 6, 2005 at 7 p.m.
Suburban Eye Care, PC: 32415 Five Mile, Livonia
Seating is Limited. Please call 734-525-8170
to reserve your place.

Members of College of Vision Development & Parents Active for Vision Education

DISCOVER SCHOOLCRAFT COLLEGE

NEW SCHOLARSHIP TARGETS ADULT LEARNERS AGE 25 AND OLDER

YOU MAY BE ELIGIBLE FOR THE NEW RETURN TO LEARN SCHOLARSHIP, WITH AWARDS RANGING FROM \$500 TO \$1,000 FOR THE 2006-2007 ACADEMIC YEAR, IF YOU ARE:

- Age 25 or older
- Planning to attend Schoolcraft College in the winter 2006 semester which begins January 14
- A first-time Schoolcraft College student or readmit student who has been away from Schoolcraft for more than two years and
- Intending to earn a Schoolcraft College certificate or associate degree

Return to Learn

Schoolcraft College is a partner in the Governor's Initiative to encourage Michigan adults to complete a college degree.

CONTACT
 Cindy Cicchelli, Information Specialist
 Schoolcraft College Counseling Office
 McDowell Center, Room MC 275
 18600 Haggerty Road
 Livonia, MI 48152
 734.462.4400 ext. 5202
 www.schoolcraft.edu/r2l

School districts support group health care legislation

BY ALEX LUNDBERG
STAFF WRITER

A group of Michigan school districts from all over the state are banding behind legislation that will allow them to purchase health care and other benefits as a group in the hopes of avoiding the recent fate of General Motors.

The Affordable Benefits Coalition is backing a package of bills heading through the Michigan legislature that would allow school districts to form into purchasing pools to find health plans to best meet their needs and reform how retirement benefits are administered.

Bill Nowling is a public relations specialist with the Rossman Group, a firm hired by ABC to push its agenda. He said access to accurate health

care use information will give districts good tools to comparison shop.

"This is key, it's information the districts can't get from insurers now," Nowling said. "The pools would have accurate data about what kinds of health care services had been used, how many times and how much those procedures cost."

The teachers union, the Michigan Education Association, isn't happy about the ABC Director of Communications Margaret Trimer-Hartley said, without changes, the union couldn't support the effort.

"The language that defines 'carrier' excludes the Michigan Education Special Services Association, which is 55 percent of the market," she said. "They should be allowed"

She added there's no provision to pre-fund any of the benefits in the ABC plan, creating a crisis if anyone asks for their benefits early. There's also a significant risk of insurers picking and choosing who they'll cover and who they'll choose to ignore.

By releasing the claims data, providers can cherry-pick the youngest, healthiest districts and ignore the others," Trimer-Hartley said. "That's going to undermine attempts to insure everyone."

She said the nation as a whole would do well to start addressing those things that are driving the cost of health care: the millions of uninsured, unaddressed problems with Medicare and Medicaid and the health habits of the country.

SCHOOLS BACK PLAN

Oakland Schools Director of Government and Community Services Brian Whiston said Oakland has been behind the coalition from its inception and added that Michigan schools can't wait much longer for relief.

Health care and retirement costs are skyrocketing," Whiston said. "We got a \$175 per pupil per year increase in the foundation grant this year. Currently, we've got \$17 billion in unfunded costs. We would have to get a \$200 per year per student increase in the foundation grant to cover the costs of those increases alone. We've got to either close buildings, eliminate programs and increase class sizes or come up with some alternatives."

Without new ideas, like

the ABC, he said school districts are going to have to increase taxes or eliminate jobs — both unacceptable alternatives.

The Tri-County Alliance for Public Education, an association of all public school superintendents in Wayne, Oakland and Macomb Counties, is backing the ABC initiative. Executive Director Kathleen Booher said public schools are facing the same grim realities recently visited on the auto industry.

Public schools cannot afford the current costs of benefits and health care," she said. "They don't want to reduce benefits but they have to provide them at a more affordable cost."

She said state funding of public education does not meet

the needs of districts and a number of them are facing bankruptcy. Most people aren't aware of this.

Local communities would be surprised to hear who is going to come up short in the next few years," Booher said.

There are districts that are two years from great difficulty. People perceive their districts are in good condition but the state has not provided sufficient funding for three years straight."

The coalition includes the Michigan Association of School Boards, the Detroit and Michigan Chambers of Commerce, the Oakland Schools, Wayne Regional Educational Service Agency and sister educational service organizations in Ottawa, Muskegon, Kalamazoo and Kent.

Contest winners play at Schoolcraft

Plymouth piano teacher Brenda Krachenberg knows that her 6-year-old pupil, Ivy, can't deal too well with octaves or reach the pedals yet. Nevertheless, she has entered Ivy into the Ann Arbor Bach Association competition. Ivy will play two Bach minuets from the Anna Magdalena Notebook on Dec. 3, and reach the advanced age of 7 on Dec. 4.

The public can listen to winners of the Bach competition at 7 and 8 p.m. Friday, Dec. 9, in the Presentation Room of the Visi-Tech Center at Schoolcraft College. The recitals are free and will spotlight the 35 winners.

Ivy, a Canton resident, is a second grader who has been studying piano since the first grade. She has drive and talent, said her teacher Krachenberg, and has been preparing her pieces since the summer, beginning to polish them by September.

"To her, this is not a competition," said Krachenberg. "It is a performance opportunity. She will go and play. I think she will do just fine, and she is ready to play. The pieces were very challenging for her, but she was eager to try and is very ambitious."

Donald Morelock, professor of music at Schoolcraft and director of the Ann Arbor Bach Association, said this is one of the strongest competitions in Michigan for pianists ages 5 through 18. This year there are 135 entries, which represents a 300 percent growth in 15 years. The majority of performers live in southeastern Michigan, and judges represent college and university music departments from Michigan and Ohio.

"The competition is good for teachers, parents and students so that they can hear other pianists play," said Morelock. "It is part of Schoolcraft's identity to work with the community, colleges and universities to foster high-quality performance. I encourage the entire community to come and hear these students play."

The Bach competition is one of four music competitions sponsored by Schoolcraft College, which involves almost 400 musicians. The others include Sonata Festival, Saturday, Feb. 4, Sonata Festival, Saturday, Feb. 11, and the Schoolcraft Piano Honors Auditions, Friday and Saturday, March 31 and April 1.

For more information, call the Schoolcraft Music Office at (734) 462-4403.

Medicare beneficiaries: More options from the name you TRUST.

HAP Senior Plus
Henry Ford Health System

Starting at **\$20**/mo

This plan combines the strength of HAP's HMO with the experience of the Henry Ford Health System and includes all the benefits of original Medicare + supplemental coverage for co-insurance and deductibles + Prescription Drug Coverage + worldwide emergency coverage — all in one plan. Available to residents of Wayne, Oakland and Macomb counties, this plan includes Henry Ford Hospital, Henry Ford Medical Group, Henry Ford Bi-County Hospital and Henry Ford Wyandotte Hospital. Whether you are traveling worldwide or staying close to home, Senior Plus has you covered.

With Prescription Coverage

Basic Rx \$50/mo	Enhanced Rx \$70/mo
---------------------	------------------------

HAP Senior Plus

Starting at **\$65**/mo

Add the power and security of HAP's trusted HMO to get all the benefits of your original Medicare + supplemental coverage for co-insurance and deductibles + Prescription Drug Coverage + worldwide emergency coverage — all in one plan. And, with our expanded 9-county service area that includes 36 hospitals and more than 3,500 physicians located throughout southeast Michigan, you'll have an even greater choice of doctors and hospitals. Whether you are traveling worldwide or staying close to home, Senior Plus has you covered.

With Prescription Coverage

Basic Rx \$98/mo	Enhanced Rx \$117/mo
---------------------	-------------------------

Alliance Medicare PPO

Starting at **\$80**/mo

HAP's affiliate, Alliance Health and Life Insurance Company, brings a flexible PPO to provide all the benefits of original Medicare + supplemental coverage for co-insurance and deductibles + Prescription Drug Coverage + worldwide emergency coverage — all in one plan. Backed by our experienced, local customer service team, you'll have the freedom to choose any provider without a referral. Whether you are traveling worldwide or staying close to home, Alliance Medicare PPO has you covered.

With Prescription Coverage

Basic Rx \$113/mo	Enhanced Rx \$132/mo
----------------------	-------------------------

**HAP's Medicare Advantage brings it all together...
Medicare + Medicare Supplement + Prescription Drug Coverage
+ Worldwide Emergency Coverage all in one plan!**

Medicare Rx
Prescription Drug Coverage

powered by

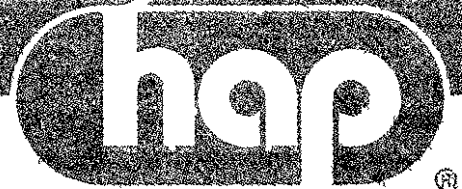

Health Alliance Plan (HAP) and Alliance Health and Life Insurance Company each have a Medicare contract with the federal government. To take advantage of these plans, you must continue to pay your Medicare Part B Premium.

Call now to find the plan that's right for you.

1-800-971-7878, TTY/TTD 1-313-664-8000

*PPO is a product of Alliance Health and Life Insurance Company, a wholly owned subsidiary of Health Alliance Plan. PPO is powered by HAP

THINKING ABOUT
A NEW FURNACE
LENNOX
FREE ESTIMATES
(734) 525-1930
Our 31st Year!
UNITED TEMPERATURE
8919 MIDDLEBELT • LIVONIA



Greek salad tossed TASTE B7

Service contracts often worth expense APPLIANCE DOCTOR B3

Fruit of the spirit can make you thin BELIEFS & VALUES B5

Ken Abramczyk, editor
(734) 953 2107
Fax (734) 591 7279
kabramczyk@hometownlife.com
www.hometownlife.com

Walk for Greenmead



PHOTOS BY BILL BRESLER | STAFF PHOTOGRAPHER

Walk in the Kusch family front door and meet the bear family



Rae Anne and David Kusch will have three trees for the holidays. Their house is one of seven on the Christmas Walk tour in Livonia this year.

Holiday homes help out

BY KEN ABRAMCZYK
STAFF WRITER

A whimsical family of bears appears with gifts on a sled. Garland and holly ribbon wrap a staircase, hung with personalized stockings, soon to be filled on Christmas Eve.

A 12-foot silver and gold tree in the great room will be adorned with angels and ornaments collected on world travels. Dickens Village scenes add to the holiday ambiance.

It's all in the home of David and Rae Ann Kusch on Maria Court, one of seven residences in Livonia on the 17th annual Friends of Greenmead Christmas Walk, scheduled 10 a.m. to 5 p.m. Saturday, Dec. 3 (see related item).

Proceeds from the walk are designated for the restoration and preservation of Livonia's Historic Greenmead, a village at Eight Mile Road and Newburgh.

"We're very excited," said David Kusch. "We've always decorated for the holidays and had family and friends over to enjoy it."

"We turn the place into what I call 'the Christmas Palace,'" Kusch said. "We each had our own Christmas collection, and we've added to it every year that we've been married."

DECOR

And it won't be just the great room all decked out. Golden birds and pine cones, velvet burgundy poinsettias, bows and beads make the tree at the top of the steps sparkle.

Decorations upstairs are designed to welcome family and guests who stay during the holiday season.

Downstairs, plaid ribbon, family mementos and photos adorn the family tree that displays ornaments given to each family member at a dinner Christmas Eve each year. Dickens Village scenes catch your eye about the room.

The room is decorated to invite family and friends for

Accents



Potters Market

The 30th Anniversary Potters Market will take place Friday-Sunday, Dec. 2-4, 876 Horace Brown Drive in Madison Heights.

Horace Brown Drive is one block south of 13 Mile and west of John R, between Barrington Boulevard and Montpelier Road.

Hours are 10 a.m. to 8 p.m. Friday, 10 a.m. to 6 p.m. Saturday, 10 a.m. to 5 p.m. Sunday. Admission and parking are free. Strollers aren't permitted.

A special preview sale will take place 6-9 p.m. Thursday. Admission to the preview sale is \$10.

The Potters Market is the largest pottery sale of its kind in the country, featuring more than 40,000 pieces by 137 artists.

It is presented by the Oakland Community College Royal Oak Campus ceramics department.

The featured works will include pots, vases, platters, tiles, mugs, bird baths, jewelry, ceramic-framed mirrors, sculpture, lamps and tile-topped tables.

Selections will range from functional to decorative to whimsical and include products in stoneware, earthenware, porcelain, raku and smoke-fired pottery.

Among the items will be Ruth Rycroft's "spirit houses," one of which is shown here. She describes them as funky English cottages, each one with its own style and spirit.

Rycroft, a Farmington Hills resident, started studying pottery 20 years ago at Pewabic Pottery. After taking a six-year break to have and raise her children, she came back to her passion for crafting pottery about six years ago.

"My goal is to create every sort of pottery and for everything to be as unique as possible," Rycroft said.

The bulk area is a popular bargain feature of the sale. Thousands of items priced from \$5 to \$25 are found here.

For more information about the Potters Market, call (248) 246-2686 or visit www.pottersmarket.com.

Festival continues

The Festival of Trees, a fund-raising event to benefit Children's Hospital of Michigan, continues to Sunday, Dec. 4, at the Rock Financial Showplace, 46100 Grand River in Novi.

Hours are 10 a.m. to 9 p.m. Thursday-Saturday, 10 a.m. to 6 p.m. Sunday. Admission is \$10 for adults, \$8 for seniors and ages 2-12, free for under age 12.

Visit www.fot.org or call (313) 966-TREE for information.



David Kusch's Dickens Village is on display on the home's lower level.

FRIENDS OF GREENMEAD CHRISTMAS WALK

■ **What:** 17th Annual Friends of Greenmead Christmas Walk featuring seven homes. Proceeds benefit restoration and preservation of Livonia's Historic Greenmead.

■ **When:** 10 a.m. to 5 p.m. Saturday, Dec. 3

■ **Where:** Start at the Livonia Civic Center on Five Mile just east of Farmington Road, proceed to seven homes, then end the walk at Hill House inside historic Greenmead, where hot chocolate and homemade cookies will be served. Shoes must be removed before entering homes.

■ **Tickets:** \$9 per person in advance, \$10 day of walk. Tickets can be bought at any of the Livonia libraries, the Civic Center Library Gift Shop, Greenmead and the Department of Community Resources on the fifth floor of the Livonia Civic Center.

■ **Information:** Call (734) 466-3540 or (734) 425-4855.



Rae Ann Kusch hangs stockings on the staircase bannister.

Pick a perfect gift for the gadget lover in your life

It's wrapping paper season again! I've spent the last month checking out a variety of nifty gadgets, any of which would make a great gift for your favorite friend, relative, co-worker or technology columnist.



Tech Savvy

Rick Broida

For starters, it's gorgeous. Of the three available colors, I'm partial to the metallic, sports car-like burnt orange.

It's also incredibly thin, measuring all of

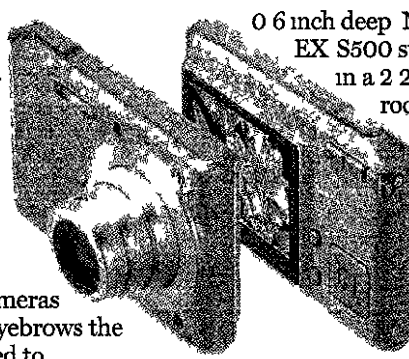

Some of the year's best gadgets make for some of the year's best gifts. The incredibly thin Casio Exilim EX-S500 packs in a roomy 2.2-inch LCD and a 3X optical zoom lens, and snaps 5-megapixel photos.

images a bit soft) and offers a wealth of user-friendly features.

The only thing I don't like about the EX-S500 is its lack of an optical viewfinder. You have to use the LCD to frame your

shots. Nevertheless, the EX S500 still manages to pack in a 2.2-inch LCD (quite roomy by digital camera standards) and a 3X optical zoom lens.

And did I mention it snaps 5-megapixel photos? I don't mean to gush, but this camera truly is a marvel of modern engineering. It takes bright, colorful pictures (though serious photographers may find the

shots. The camera has a list price of \$399, but I've seen it selling online for less than \$300.

DVD TO GO

Portable DVD players are everywhere these days, but many models are so big and bulky that they're not particularly travel-friendly.

That's why I like the Axion AXN-6042 (axiontv.com), which looks like a portable CD player but has a 4.2-inch color screen on top.

It's very compact, it comes with two headphone jacks (as well as built-in speakers), and it can output video to a TV. Speaking of TV, an optional adapter lets



The compact Axion AXN-6042 comes with two headphone jacks as well as built-in speakers, and can output video to a TV. It's a splendid travel companion for children, teens, and anyone who likes to travel light.

you tune in local channels.

Not bad for \$130, though the low-resolution screen doesn't exactly make movies look their best. Even so, the AXN-6042 is a splendid travel companion for children, teens, and anyone who likes to travel light.

IPOD FOR EVERYONE

Listening to an iPod doesn't have to be a solitary experience. My wife's iPod Mini has taken up almost permanent residence in the Altec Lansing mMotion iM7 (altec Lansing.com), a portable speaker system that's compatible with all dockable iPods.

There are lots of similar gizmos on the market, but most of



Listening to an iPod doesn't have to be a solitary experience. The Altec Lansing mMotion iM7 is a portable speaker system that's compatible with all dockable iPods.

PLEASE SEE BROIDA, B3

MARKETPLACE

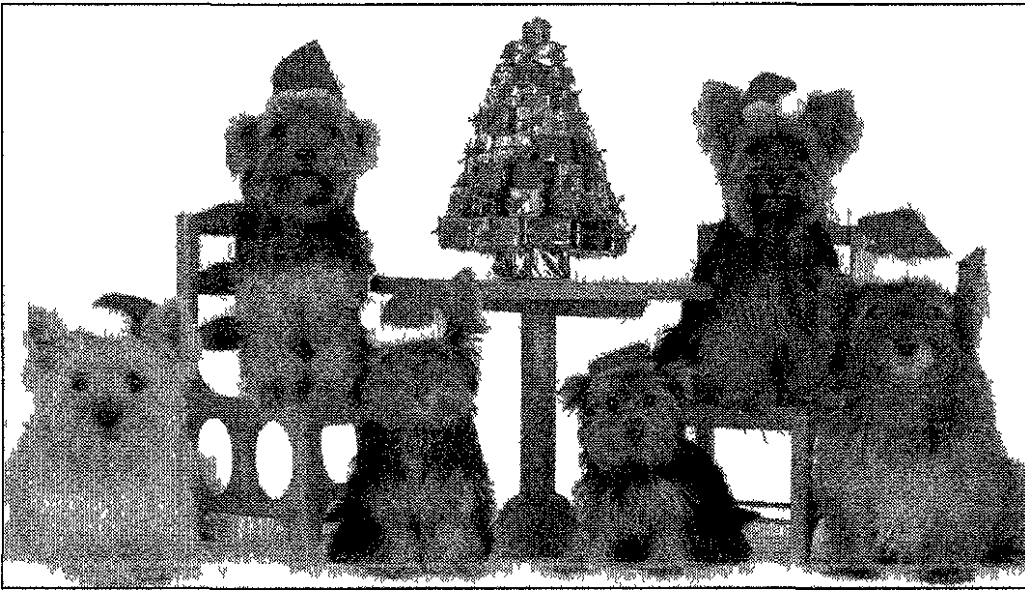

Pet project

Pet Star greeting cards, by the Pet Star Corporation of Miami, are a fun and unusual way to share your love of those with four feet and a wagging tail. There's a card to match your pet and your personality - from whimsical "interfaith" holiday cards featuring a group of different breeds wearing yarmulkes and Santa hats, to Halloween greetings starring pooches as pumpkins and witches. The fun doesn't stop with holiday cheer. There are patriotic puppy cards, including dogs in sailor uniforms and camouflage. Most Pet Star cards are blank inside with plenty of room for your personal message. Interfaith, Christmas and Hanukkah cards feature appropriate sayings inside. The high-quality cards are printed on heavy stock and measure 4-1/4 by 5-1/2 inches. A pack of six cards and envelopes costs \$10. Pet Star greeting cards are sold and shipped globally at www.petstar.net or by calling (305) 233-7722. Shipping is free in the United States. The cards are available at select retail outlets. Pet Star began as a successful photography studio for pets. It is involved in a wide variety of charitable organizations, including Canine Companions, the Humane Society, Adopt-a-Pet, Children's Home Society and the Actor's Playhouse.



Read the fine print: Service contracts often worth expense

Service contracts or extended warranties have been around now for a lot of years and the question is still asked by many people "Are they worth the expense?"

Depending on your viewpoint, there are several ways to answer the question without



Appliance Doctor

Joe Gagnon

making it sound all confusing. YES, service contracts and/or extended warranties are very worthwhile, provided the cost of such is reasonable.

This answer only creates another question of what is considered reasonable, which leads me to explain the history of contracts and warranties.

Many, many years ago when you bought a major home appliance, the retailer would offer you an extended service agreement on the product that would cost so much for each year of coverage after the initial purchase.

The older the product, the more you paid for the coverage. It was possible that once the product reached 10 years of age, you paid out a lot more for the warranty than you actually paid for the product.

Some appliance retailers really pushed their employees to sell these warranties, such as Montgomery Ward, which was eventually sued by some employees who were fired for not selling enough extended service contracts. Highland Appliance had seven employees on the phones six days a week, selling these contracts to their customers who had already bought contracts that were about to expire.

All in all, it was very big

Many, many years ago when you bought a major home appliance, the retailer would offer you an extended service agreement on the product that would cost so much for each year of coverage after the initial purchase. The older the product, the more you paid for the coverage. It was possible that once the product reached 10 years of age, you paid out a lot more for the warranty than you actually paid for the product.

business right from the start of it. It was reported that General Electric had cleared a profit of \$22 million a few years ago, just by selling enough service contracts.

There was some trickery used by some retailers at the point of sale where they scared the consumer into buying a contract or they informed the customer of facts that distorted the truth.

There was plenty of ammunition for Esther Shapiro to write several articles on the subject in her newspaper columns.

The conclusion back then was that contracts were way overpriced and not affordable by the average consumer, and yet Montgomery Ward made more money one year selling service contracts than it did in selling the appliances.

After 1996, the utility companies came out with a plan for their customers that would cover not only appliances but also the air conditioning, furnace and hot water tank.

This means that you can

have coverage on seven products or so for less than \$300 per year. Compared to the old way of business as described above, you can now get all this for the price of what some consumers had to spend for coverage on just one appliance.

SHOP AROUND

How can anyone say today that these extended contracts aren't worth it?

Some do because the contract doesn't cover every component on the product. I can understand and accept that fact and realize that most high-failure parts are covered. With the costs of service calls and labor always on the increase, it doesn't take much for one call per year to equal the cost factor you spend on these warranties.

When you are out shopping for an appliance these days, you owe it to yourself to listen to any sales pitches on extended warranties.

Evaluate what is being said and, very important, how much it costs.

As anything produced in this country, the cost seems to go down with increased production. This is true also of service contracts.

You now have more than one source to obtain one, so shop around. It's insurance that products won't cost you an arm and a leg after you make the initial purchase.

You already know my viewpoint on how they build products today, compared to yesterday.

A service contract or extended warranty might be the smartest thing you can buy. Stay tuned.

Joe Gagnon can now be heard on WWJ 950 and WXYT 1270. He is a member and past president of the Society of Consumer Affairs Professionals. His phone number is (248) 455-7281. Do you have a question about an appliance or a problem you have with an appliance? E-mail your question to kabramczyk@hometownlife.com and it will be forwarded to Joe Gagnon.

BROIDA

FROM PAGE B1

them are, well, hideously ugly. Not so the cylindrical, elegant iM7, a lovely complement to the iPod itself.

The iM7 cranks out deep, boisterous sound thanks to its built-in subwoofer.

It can run off batteries or AC power, and it comes with a wireless remote.

Plus, it has input jacks for connecting other audio devices and a video output for watching iPod videos on your TV.

At \$249, the iM7 is a pricey accessory, but it's absolutely awesome for freeing your music from the confines of your iPod earbuds.

Speaking of mobile devices that involve your ears, the Boostaroo Revolution (boostaroo.com) is a handy accessory. It splits and amplifies headphone output, thus allowing two listeners to share the same iPod, portable DVD player, or whatever.

I use mine in the car, where I have my MP3 player connected to the stereo.

The player's output level isn't

quite loud enough, but the Boostaroo Revolution gives it a major volume boost (400 percent, according to the company).

Unfortunately, the little white gizmo sells for \$79.95, which I think is overpriced. Plus, it relies on AAAA batteries (no, that's not a typo), which aren't always easy to find.

Solution: Buy the original Boostaroo instead. It is \$29.95, runs on AA batteries, and does pretty much the same thing.

FREE INNER SPIELBERG

Your spiffy new camcorder isn't of much value without a good video-editing program. I've tried most of them, and I remain partial to Pinnacle Studio Plus (pinnacle.com) for its simple interface and versatile feature set.

The latest version, Studio Plus 10, lets you copy camcorder footage straight to DVD, no editing required. It also adds support for high-definition (HD) camcorders.

I'll write more about the program in a future column. In the meantime, if you're looking for an inexpensive (less than \$100) but extremely capable video editor, this is it.

COOL GIFTS FOR KIDS

Want to indulge the kids with a new computer game that doesn't involve carjacking and other felonies? Consider Cosmic Blobs (cosmicblobs.com), which lets youngsters express their creativity by creating cool 3D animations (Pixar, here they come!).

It's a slick program, chockfull of tools for designing animals, vehicles, characters and objects, then animating a scene. However, I disagree with the company's claim that Cosmic Blobs is suitable for children as young as 7.

There's a fairly steep learning curve, so I'd recommend it for ages 10-15.

Children of all ages will love Disney's Magic Artist Deluxe. It's an older program, meaning you can scoop it up online for around \$15, but it's an absolute gem.

Rick Broida writes about computers and technology for the Observer & Eccentric Newspapers. Broida of Commerce Township is the co-author of numerous books including *How to Do Everything with Musicmatch* and *101 Killer Apps for Your Palm Handheld*. He welcomes questions sent to rick.broida@gmail.com.

Kitchen Top Shop Inc.

up to **65% off** **STARMARK** Cabinetry

248.477.1515

Open till 8 p.m. Tues. & Thurs.

AMERICAN HANDYMAN

734.459.9941

DRYWALL • PAINTING • MINOR PLUMBING REPAIRS
ELECTRICAL • CARPENTRY • KITCHEN & BATH REMODELING
EXTERIOR HOLIDAY DISPLAY INSTALLATION

20% OFF ANY REPAIR (Over \$250)
Coupon Only • Expires 12-31-05

CHIMNEY CLEANING \$39.99
Deodorize Chimney, Clean Glass Doors, Safety Inspection
Coupon Only • Expires 12-31-05

CHRISTMAS IN THE COUNTRY

Pick your tree while the kids visit Santa!

Saturday and Sunday call for details.

25-50% OFF ALL LIFE LIKE TREES

50% OFF 7.5' GRAND SPRUCE
1500 clear lights
Reg. \$399
6400-089

\$5.00 OFF Fresh Cut Tree
6' or larger • Limit one • Expires 12/11/05

PLYMOUTH NURSERY
Christmas in the Country

734-453-5500
www.plymouthnursery.net
Mon-Fri 9-8 • Sat 9-6 • Sun 10-6
OFFERS EXPIRE 12/7/05

9900 Ann Arbor Rd./Plymouth Rd.
7 Miles West of I-275 • 1 1/2 Miles South of M-14
Corner of Gotfredson Rd.

GREENMEAD

FROM PAGE B1

conversation or to sit by the fire to prepare Christmas letters and cards

The Kusches have only lived in the house since December, but they enjoy the Boulder Pines subdivision. They are pleased to help raise money for Greenmead.

"Anything that preserves history preserves the past and it is important to the community," David said.

"You can go to Greenmead for lots of events. We go to the Highland Games and farmers markets, plus they have events that you can bring the kids to. It is one place that includes the family in activities."

David is principal at St. Paul's Lutheran School at Eight Mile and Middlebelt in Farmington Hills. He brings his students to Greenmead for a festival of cultures.

"There's enough room there that you can bring hundreds of kids every day," Kusch said. "Again when you look at Greenmead from a historical standpoint, it's a chance to talk about life and what it was like in the olden days."

At the Kusch home, David enjoys the 12-foot tree in the living room.

"We have many decorations, purchased as we travel, that tell

of all the places we've been," Kusch said.

David also receives pieces for Dickens Villages each year from Rae Ann and other family members to add to the collection.

OTHER HOMES

There will be plenty of sights on the walk.

■ A home on Golfview features kitchen renovations and the addition of hardwood floors. A second kitchen renovation and a great room was added in 2004.

There's a collection of Santa Clauses, some from other parts of the world, including Scotland, Poland and the Ukraine.

The new great room features a Children's Tree with all the ornaments collected over the years, each of which holds special places and memories.

■ Visitors will journey to old Rosedale Gardens to a home on Auburndale, where a Victorian-style tree in the living room and a 3-1/2-foot tree in the dining room are decorated with antique prisms.

The family room displays an antique Christmas band. Outside you will see an antique sleigh filled with gifts that has been in the family since the 1940s.

■ A two-story Mediterranean-style home on Fairlane features marble tile

floors in the foyer, sunroom and atrium, and granite tile floors in the kitchen and dining room.

A dining room is described as exquisite with a high-gloss black, glass-topped table with matching chairs and credenza with a dramatic crystal chandelier.

The kitchen contains Old World charm with hand-crafted lighted cabinets with glass doors, ceramic tile and family curios.

■ The owners of a home on Stamford remodeled the kitchen, family room and bathrooms and installed hardwood floors. New doors also were installed and the home's exterior was revised from a Tudor colonial look to the colonial look preferred by the homeowners.

■ A custom Cape Cod home on Vanderhaven was built in 2004. A rustic theme displays the homeowners' love of nature. Warm brown tones are exhibited throughout the home.

A double-sided fireplace is a perfect location to display the village and working tram. A 9-foot Christmas tree adorns the great room and is decorated in a rustic, woodland theme.

■ A Victorian colonial on Park has an Amish gazebo, brick walkway, Victorian lamppost and vine-covered arbor. Each room is decorated for Christmas with its own theme.

The living room is highlighted

by a Victorian tree and porcelain dolls, the family room has snowmen. A Christmas train circles the ceiling.

The entertainment room has been taken over by Santa Claus, featured in various styles and sizes. The home office has toy soldiers, while the guest room contains collectibles.

■ At Greenmead, a natural Christmas is the theme for this year's Hill House decorations, decorated by several local Quester groups.

The library features a Christmas tree filled with dried hydrangeas, foliage and birds. The dining room table and chairs are original to the home. Decorations include a selection of greens, berries and fruit arrangements.

Variety and beauty are home qualities the organizers look at when organizing the annual Christmas Walk.

"We look for homes that are tastefully decorated," said Janet Bennet, president of Friends of Greenmead.

"We'll put together a walk with homes that have a variety of styles in decorating. Some people like homespun, others like modern and we try to get a variety."

Since 1989, Friends have raised \$247,000 through walks, picnics and fashion show fundraisers.

kabramczyk@hometownlife.com
(734) 953-2107

The Original BURTON'S
Plumbing & Heating
34224 MICHIGAN AVE. WAYNE
734-722-4170

BATHROOM and KITCHEN REMODELING
COMPLETE PLUMBING SERVICE
Visit Our Showroom

Clip and Save \$25 off SERVICE CALL
Not valid with other offers or coupons. Call Burton Plumbing at 734-722-4170. Good thru 2-28-06.

Clip and Save \$35 off WATER HEATER INSTALLATION
Not valid with other offers or coupons. Call Burton Plumbing at 734-722-4170. Good thru 2-28-06.

Clip and Save \$100 off HOME REPIPE
Not valid with other offers or coupons. Call Burton Plumbing at 734-722-4170. Good thru 2-28-06.

Don't Compromise ...Customize!

Now you can have wall systems, entertainment centers, or bookcases custom built just for you by master craftsmen using your measurements and the finest oak and cherry (no particle board). Best of all, we will do this at about the same price as production made systems. See over 40 entertainment centers and wall systems on display. All units can be sized to fit any wall, any TV, any sound system.

There's nothing better than being "front row center" in your own home theater. Our Cinema Collection is ideal for TV and movie viewing with generous proportions, plush cushions and a look that's just what the script called for. Choose fabric or leather with manual or power reclining units.

See our large selection of bedroom, dining room and living room furniture including reclining products by **LA-Z-BOY**.

Wm. C. Franks FURNITURE
2945 S. Wayne Road • Wayne
(4 Blocks N. of Michigan Ave.)
734-721-1044

Store Hours:
Mon., Thurs., Fri. 9-9
Tues., Wed., Sat. 9-6

HOMETOWNlife.com

We've recently refurbished our website. Given it a fresh coat of paint so to speak. We wanted it to be easier to navigate. And great to look at. And useful for everyone. It took us a while but we think we made all that happen. Check it out. A lot of what you see is still there—local news, special sections, classifieds and some of it is new like our partnership with CareerBuilder.com, Apartments.com and Cars.com., three great sites to use when you want really great results. So grab your mouse and see what's happening on hometownlife.com

THE Observer & Eccentric
NEWSPAPERS
WHERE HOMETOWN STORIES UNFOLD

OAKLAND COUNTY: 805 East Maple, Birmingham 48009 . 248-901-2500 . FAX 248-901-2553
WAYNE COUNTY: 36251 Schoolcraft, Livonia 48150 734-953-2153 . FAX 734-953-2121
HOMETOWNLIFE.COM

4-MONTH CD 12-MONTH CD

4.15% APY | 4.50% APY

\$1,000 minimum & Circle Checking

Is your money living up to its potential?

To open a CD, call 1-877-TOP-RATE or visit us in person at any Charter One branch.

Charter One
Not your typical bank®

Member FDIC. All accounts and services subject to individual approval. Annual Percentage Yield (APY) is accurate as of this publication date. Limited time offer may be withdrawn at any time. This offer cannot be combined with any other CD offer. Circle Checking Account with \$50 minimum opening deposit is required. Other rates and terms available. Minimum opening term deposit \$1,000. \$250 for an IRA CD. Penalty for early withdrawal. RA fees may reduce earnings. See a banker for details and FDIC coverage amounts and limitations.

RELIGION CALENDAR

If you want to submit an item for the religion calendar fax it to (734) 591 7279 or write Religion Calendar *Observer Newspapers* 36251 Schoolcraft Livonia MI 48150 The deadline for an announcement to appear in the Thursday edition is noon Monday

DECEMBER

Concert

Featuring Michael Card and the Ward Church Choir & Orchestra 7:30 p.m. Friday Dec. 2 at Ward Evangelical Presbyterian Church 40000 Six Mile Northville Tickets \$10 \$5 in advance for pre-concert dinner for singles at 6 p.m. in Parlor C317 Free childcare Call (248) 374 5920

Marian Advent retreat

9 a.m. to 5 p.m. Saturday Dec. 3 in Madonna University Center and Chapel 14221 Levan Livonia This year's theme is Mary's Christmas and Rev. Daniel Jones professor Sacred Heart Major Seminary will lead events Activities include reflection and prayer 3 conferences lunch individual reconciliation Exposition and Benediction of the Bless Sacrament the mysteries of the rosary with meditation prepared and led by students and Sunday Mass in the University Chapel at 4 p.m. The cost is \$18 and includes lunch and refreshments Reservations required call (734) 432 5524

Craft show

More than 80 crafters show their wares 9 a.m. to 4 p.m. Saturday Dec. 3 at St. Thomas a Becket Church 555 S. Lilley at Cherry Hill Canton Bake sale and lunch available Admission \$2 children under age 12 free Call (734) 981 1333

Holiday marketplace

10 a.m. to 2 p.m. Saturday Dec. 3 at Hosanna Tabor Lutheran School Gym 9600 Levere Redford Come do your Christmas shopping with us Vendors include Arbonne Arvon Creative Memories Discovery Toys Reliv Nikken Stamping Tupperware and more Call (313) 937 2424

Concert

The Detroit Lutheran Singers Christmas Concert 7:30 p.m. Sunday Dec. 4 at Holy Cross Evangelical Lutheran Church 30650 Six Mile Livonia Tickets \$10 \$7 seniors and students Call (734) 427 1414

Cookie walk

After 8 a.m. and 10 a.m. services Sunday Dec. 4 at Trinity Episcopal Church 11575 Belleville Road Belleville Call (734) 699 3366 Stop on yummy treats for the holidays

Concert

Featuring Schoolcraft College Choral Union's presentation of Vivaldi's Gloria and works by Buxtehude and Finzi 4 p.m. Sunday Dec. 4 in the sanctuary at St. Matthew's United Methodist Church 30900 Six Mile between Merriman and Middlebelt Livonia (734) 422 6038 No charge but donations accepted during intermission Also performing is the Oakland University chorus Call Schoolcraft College's liberal arts department for more information (734) 462 4435

Advent celebration

Festival of lessons and carols in the manner of King's College Chapel Cambridge England 7 p.m. Sunday Dec. 4 featuring the St. John's Episcopal Church parish choir hand bell choir children and youth choirs SonShine and men & of the church in Plymouth 574 S. Sheldon south of Ann Arbor Trail No charge and open to the public A reception will follow the service Call (734) 453 0190

Open house

For the Manresa Jesuit Retreat House 3 p.m. Sunday Dec. 4 at 1390 Quarton and Woodward Bloomfield Hills Meet the Jesuits and discover the programs and ministries offered to the community For information call (877) MANRESA or visit www.manresa.org The mission of Manresa is to help men and women grow spiritually through prayer reflection and teaching according to the tradition of St. Ignatius Loyola

Concert

Birmingham Concert Band present Holiday Ornaments 3:30 p.m. Sunday Dec. 4 at the Lutheran Church of the Redeemer 1800 W. Maple at Chesterfield Birmingham The band will be joined by the Lutheran High Northwest Concert Choir The band is looking for instrumentalists to fill several sections Call Grant Hoemke musical director at (248) 474 4997

Nativity story

The Council of Orthodox Christian Churches of Metropolitan Detroit sponsors The Story of the Nativity As Told in Icons a presentation by the Most Rev. Nathaniel Archbishop of Detroit and the Romanian Episcopate of the Orthodox Church in America 6:30 p.m. Sunday Dec. 4 at St. George Romanian Orthodox Church 18405 W. Nine Mile Road Southfield The program includes a concert of Orthodox Nativity Carols and Liturgical Hymns of the Nativity by the COCC Inter-Orthodox Choir a sing a long of familiar western Christmas carols and a visit by St. Nicholas for children The event is free and open to the public A freewill offering will be taken For further information contact Janet Damian at

(313) 706 0666 or send e-mail to damjan@juno.com

Christmas concert

Bach's Magnificat and Handel's Messiah Part I featuring the Kirk Chancel Choir and soloists and members of Detroit Chamber Winds 7:30 p.m. Sunday Dec. 4 at Kirk in the Hills 1340 W. Long Lake Bloomfield Hills Tickets \$18 \$15 seniors \$12 students Call (248) 626 2515

Series on Spiritual Principals

7 p.m. Wednesday Dec. 7 to Jan. 4 at Unity of Livonia 28660 Five Mile between Middlebelt and Inkster For more information call (734) 421 1760

Journey to Bethlehem

A walk through Christmas play 6:30 8:30 p.m. Friday Dec. 9 and 2 4 p.m. Saturday Sunday Dec. 10 at Unity of Livonia 28660 Five Mile between Middlebelt and Inkster Walk and sit with the townspeople shepherds kings and angels Drink at the well and speak with the innkeeper As you walk through the 30 to 40 minute journey others will follow (about every 20 minutes) and experience the Christmas promise For more information call (734) 421 1760

Christmas with family

Celebrate the holiday season with music drama skits dance numbers flying angels big screen video and more at Christmas with the Family 2005 7 p.m. Friday Saturday Dec. 9 10 at Detroit World Outreach 23800 West Chicago Redford Desserts will be served at end of performances Tickets \$5 before Dec. 3 \$10 after and at the door Call (313) 255 2222 ext. 236

Detroit World Outreach is a non-denominational church with cutting edge drama productions energized contemporary music high tech video and lighting programs for kids and teens a great place for college students singles married adults and seniors Services are 8 a.m. and 11 a.m. Sunday (6:30 p.m. the first Sunday of the month) Sunday school for all ages at 10 a.m. and Wednesdays at 9 a.m. and 7 p.m.

Cookie walk

Holy Transfiguration Orthodox Church's 12th Annual Cookie Walk is Saturday Dec. 10 doors open at 8 a.m. sale starts at 9 a.m. and lasts until sold out Pierogi stuffed cabbage bread nut and poppyseed rolls and more than 50 different assortments of ethnic (kifle kolachy rugela koulourakia biscotti linzer) and traditional cookies and candy will be for sale at the church 36075 W. Seven Mile east of Newburgh Livonia

Cookie walk

10 a.m. to 1 p.m. Saturday Dec. 10 at St. Michael's Orthodox Church 26355 W. Chicago between Beech Daly and Inkster Redford Cookies are sold by the pound Come early for best selection

Holiday craft fair

11 a.m. to 4 p.m. Saturday Dec. 10 at Tri City Christian Center 3855 Sheldon north of Michigan Avenue Canton Admission \$1 Bake sale and refreshments available Call (734) 495 3363

Advent concert

The fifth annual Advent Concert featuring the Langsford Men's Chorus will be held 7:30 p.m. Saturday Dec. 10, at Rosedale Gardens Presbyterian Church 9601 Hubbard at West Chicago Livonia Rosedale's own Campanelle Handbell Choir will also be featured For information call Dave Conrad at (734) 717 6356 or Ron Muresan at (248) 540 0621 For information about the church visit www.rosedalegardens.org or call (734) 422 0494

Christmas Cantata

Emmanuel Celebrating Heaven's Child 11 a.m. Sunday Dec. 11 at Mt. Vernon Baptist Church 8828 Wormer Redford Everyone is welcome Call (313) 537 7480

Christmas concert

Christ Our Savior Lutheran Church of Livonia presents their annual Christmas Concert 4 p.m. Sunday Dec. 11 in the sanctuary at 14175 Farmington Road north of 196 Livonia For more information call (734) 522 6830 Featured will be the Christ Our Savior Festival Choir the Jubellation Handbell Choir the Ringers of Joy Youth Handbell Choir the Laudate Choir (grades 1-6) the Confirmation Choir (grades 7 & 8) a Brass Choir and various instrumentalists providing uplifting holiday music The concert is free and open to the public with a freewill offering being taken

ONGOING

Worship services

All are welcome to attend worship service at St. Paul's Presbyterian Church Five Mile and Inkster roads Livonia Service is held at 10 a.m. every Sunday with an education hour all for ages at 9 a.m. Call (734) 422 1470

Fall Sunday services

8:30 a.m. Holy Eucharist 9:30 a.m. Bible study and 10:30 a.m. Holy Eucharist and Sunday school at Episcopal Church of the Holy Spirit 9083 Newburgh Livonia

Sunday services

Continue with traditional worship and children's Sunday School at 10 a.m.

and adult Bible study at 8:30 a.m. at Garden City Presbyterian Church 1841 Middlebelt one block south of Ford Road The Beatitudes are now the focus of the school curriculum which features music computers games and story telling Nursery care available The Mustard Seed service at 6 p.m. offers an informal casual environment Handicap accessible Call (734) 421 7620

Unity of Livonia

Services 9:30 a.m. and 11 a.m. Sundays at 28660 Five Mile between Middlebelt and Inkster roads Call (734) 421 1760

Shabbat services

The doors of Congregation Beit Kodesh a Conservative synagogue located at 31840 W. Seven Mile between Farmington and Merriman Livonia are open to the Jewish community of southeastern Michigan Call (248) 477 8974

Bet Chaverim

Services are open to all living in the western counties including Canton Plymouth Livonia and Northville The congregation follows traditions of Reform Judaism Interfaith families welcome to attend services at 321 S. Ridge south of Cherry Hill Canton Call (734) 646 3864 for information or visit www.betchaverim.com

Trinity Episcopal Church

Sunday Services 8 a.m. and 10 a.m. Wednesday service 6:15 p.m. Bible Studies and Worship Center for all ages at 11575 Belleville Road (four miles south of Michigan Avenue) Belleville Parents with Young Children Bible Study 6 p.m. Sundays includes dinner and child care Call (734) 699 3361

Shabbat Ricks

A musical celebration precedes traditional Shabbat service once a month at Adat Shalom Synagogue 29901 Middlebelt in Farmington Hills For more information call (248) 851 5100 or visit the Web site at www.adatshalom.org

English classes

Conversational English as a Second Language classes are being offered for adults of all ages and backgrounds 7 p.m. Monday and Tuesday at Christ Our Savior Lutheran Church 14175 Farmington Road Livonia Tutors will work on a one to one ratio to help students better understand and speak the English language No charge To register call (734) 525 0191 or (734) 522 6830

Scripture from scratch

If you've always wanted to learn about the Bible from square one here's square one 7:30 p.m. Thursdays in the Activity Center at St. Aidan Catholic Church 17500 Farmington Road Livonia Call (734) 425 5950 to register

Sunday school

Congregation Beit Kodesh (31840 Seven Mile between Farmington and Merriman Livonia) is registering children age 4 and up for Sunday school Financial assistance available Special discounts for new members For more information call (248) 477 8974

Services

St. John Lutheran Church (23225 Gill Road Farmington Hills) invites the community to a new worship service 5:30 p.m. Saturdays Also Sunday traditional worship services are 8:30 a.m. and 11 a.m. contemporary service is at 9:50 a.m. and Sunday School hour for all ages is at 9:45 a.m. Call (248) 474 0584 for more information

Single Point Ministries

For ages 30 and older join more than 350 single adults 11:30 a.m. Sundays for fellowship and related topics in Knox Hall at Ward Evangelical Presbyterian Church 40000 Six Mile Northville Coffee doughnuts conversations are present Call (248) 374 5920 Tennis continues 1 p.m. Saturdays and Sundays and 4 p.m. Tuesdays at Rotary Park Six Mile and Hubbard Livonia

Bible talks

4 p.m. Sundays at the Friendship Center 1119 Newburgh Westland Call (734) 728 9157

Worship services

All are welcome to attend worship services 10 a.m. Sundays at St. Paul's Presbyterian Church Five Mile and Inkster roads Livonia For more information call (734) 422 1470

The Gap

A new youth Sunday School (God Always Present) at Garden City Presbyterian Church 1841 Middlebelt south of Ford Road Lessons are taught using various media computers story telling games cooking music and art and a small theater complete with popcorn making machine Adult Bible study at 8:30 a.m. with a traditional service and The Gap at 10 a.m. Child care available Mustard Seed contemporary service at 6 p.m. with refreshments served afterward Call (734) 421 7620

Qigong

The ancient form of Chinese energetic medicine A safe and effective way to rid body of toxic pathogens and years of painful emotions Learn the art of natural movement and breath to cultivate vital life energy Classes at Livonia Unity 28660 Five Mile Monday - movement Qigong 7:30 p.m. Thursday - Qigong meditation 10:15 a.m. and Friday Therapeutic Qigong 7:30 p.m. Call (810) 813 4073 for

more information or send e-mail to gary@energeticarts.org

Worship services

8 a.m. and 11 a.m. Sundays with an education hour 9:30 to 10:40 a.m. at Prince of Peace Lutheran Church 37775 Palmer Westland Social hour follows each service Call (734) 722 1735

Detroit World Outreach

Nondenominational church with cutting edge drama productions contemporary energized music high tech video and lighting relevant life changing messages ministries for all ages services times are 8 a.m. 10:45 a.m. and 6:30 p.m. Sunday (Sunday school for all ages at 9:30 a.m. junior high serves for grades six eight at 10:45 a.m.) Wednesday services 8:45 a.m. and 7 p.m. (Family Night) and service for ages 18 28 at 7:30 p.m. Tuesday at 23800 W. Chicago Redford Call (313) 255 2222 or visit www.wayofwvictory.com

Worship services

All are welcome to attend worship

services 10 a.m. Sunday at Church of Our Saviour Presbyterian 6655 Middlebelt West Bloomfield For more information call (248) 626 7606

Aerobic class

Trinity Church of the Brethren 27350 W. Chicago at Inkster is offering a Women's Low Impact Aerobic Class to the community every Monday and Wednesday at 7 p.m. in the church basement To participate in this cost free 30 minute class wear comfortable exercise attire (floor mats optional) For more information call the church office (313) 937 1199

Bible studies

Led by C. Jack Brinkman 8:9 p.m. Thursdays at the Birmingham YMCA 400 E. Lincoln Brinkman wrote the book *The Word of God Jesus Christ* Part of the proceeds from book sales go to the YMCA

Community Bible study

Studying the Book of Proverbs break fast 7 a.m. or Bible study 8:9 a.m. at the American Table Eight Mile

Farmington Come when you can leave when you must For more information call (248) 924 2779

Contemporary service

New informal service in a casual environment 6 p.m. Sunday at Garden City Presbyterian Church 1841 Middlebelt south of Ford Fellowship hour after services including 10 a.m. traditional Call (734) 421 7620

Trinity Episcopal Church

Sunday worship 8 a.m. and 10 a.m. Bible studies Sundays at 8:50 a.m. and Wednesdays at 9:30 a.m. at the church 11575 Belleville Road four miles south of Michigan Avenue Belleville Call (734) 699 3361

Support group

Provides spiritual social and educational support for divorced and separated Catholic men and women 7:30 9:30 p.m. the first Wednesday of the month at St. Andrew's Parish Center 1400 Englewood Rochester For information call (248) 652 9173 or (248) 652 3860

Passages

Obituaries, Memorials, Remembrances

1-800-579-7355 ♦ fax 734-953-2232

e-mail OEObits@oehomecomm.net

BERYL LUCAS
(nee Henderson)

Age 84 passed away peacefully November 24 2005 Beloved wife of Sidney Loving mother of John (Christine) Lucas Karen (Richard) Paul & Kimberly (Matthew) Pisko Dear grandmother of John E. Lucas Erin & Christopher Paul and Mackenzie Pisko A private service will be held out of the country R.G. & G.R. Harris Funeral Home (734) 422 6720 in charge of arrangements Memorial contributions to Michigan Humane Society

DANIEL RICHARD
ANDREW

Of Livonia MI died Monday November 28 2005 age 78 Beloved husband of 56 years to Mary Louise Dear father of Michele Andrew Lescoe (Paul) and Ann Andrew King (Stephen W.) Grandfather of Monica McDowell (Mark) and great-grandfather of Carson Daniel McDowell Mr. Andrew was the first industrial coordinator for the city of Livonia from 1963 1970 He served as the chairman of the Livonia Planning Commission from 1971 1984 and was a member of Livonia's Zoning Board Appeals from 1997 2004 He was a member of the Livonia Housing Commission from 2003 2005 He served on numerous civic boards and organizations in Livonia In 1973 Mr. Andrew co-founded Damone Andrew Inc. serving as senior vice president and co-owner of this commercial real estate company head quartered in Troy MI He retired in 1999 Visitation Fred Wood Funeral Home 36100 Five Mile (one mile west of Farmington Road) Friday 2:50 p.m. and 7:00 p.m. Saturday 9:00 a.m. and Sunday 2:50 p.m. and 7:00 p.m. Scripture Service Sunday 7 p.m. Funeral Mass will be held Monday December 5th at 11 a.m. at St. Aidan Catholic Church 17500 Farmington Road Livonia Donations to the National Kidney Foundation and American Heart Association

DOROTHY ELIZABETH
PAXTON

Age 77, of South Lyon died November 26 2005 Born May 15 1928 in Chester Pennsylvania She came to the South Lyon community in 1994 from Novi She was a retired secretary from the Ford Automotive Chassis Control Division She was a member of the First Presbyterian Church of South Lyon and she volunteered with the Michigan Cancer Society Dorothy was a loving wife mother grandmother great grandmother and sister She is survived by her husband John her children Karen (Michael) Kozar and Kenneth (Teresa) Quartermus her step children Randolph Paxton and John J. (Suzan) Paxton 11 grandchildren 2 great grandchildren her brother Kenneth (Linda) McAnall, and her sisters Jean Fusco and Patricia (Bill) Coopersmith Funeral from Schrader Howell Funeral Home 280 S. Main Plymouth Saturday 7pm Visitation Friday 2:00pm and Saturday 2:00pm Memorials may be made to the American Cancer Society

In Memory Of

JULIE MICHELLE
RATKUS

November 27 1946 to November 29 2001 Four years can pass like a day or seem an eternity Time can change many things but time cannot diminish the memories, my love for you Til we meet at sunset Love Carl

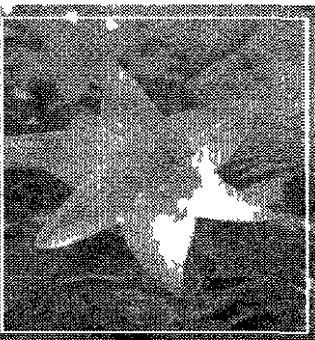

DOROTHY L. LENT

November 25 (at 91) Beloved wife of the late Wendell Lent Lent's Custom Clothing and loving mother of Linda (Stewart) Oldford Karen (James) Tobias Julie (Dale) Hall and Jamie Lent Dorothy's grandchildren Victor (Jill) West Steven (Sallie) West Keith Peltz Brian Peltz Jay (Julie) Tobias Kim Tobias Wendy Hall and Jessica Hall will miss her greatly In addition, Dorothy enjoyed 9 great grandchildren Dorothy a 73 year resident of Plymouth was born and raised in Hillsdale Dorothy was loved by a smile she knew her Always with a smile she was very active in scouting Red Cross community organizations and a 50 plus year member of First United Methodist Church Donations may be made to the Red Cross and Plymouth Historical Society A memorial service to celebrate Dorothy's life is Saturday December 3 at Plymouth's First United Methodist Church Lunch will follow the 11:00 AM service Arrangements by Vermeulen Funeral Home Plymouth 734 459 2250 www.vermeulenfh.com

JOSEPH L. O'CONNOR

Died peacefully in Ann Arbor on November 23rd, about one month before his 83rd birthday A beloved husband, father grandfather great grandfather and brother he is survived by his loving wife of 58 years Mary E. O'Connor Sister Patricia Haas (Edward) Brother Vincent (Barbara) children Terrance (Carolyn) Mary Jo (Robert Steinhilber) Karen Thomas (Donna) and Christopher (Cheryl) Regan as well as seven grandchildren, Kelly Brandy Emily Matthew, Elizabeth Christopher and Lucas and two great grandchildren Trey and Reagan. Mr. O'Connor was born January 1 1923 near Adrian He was a Navy veteran who served in the Pacific throughout World War II He went to college on the GI Bill at the University of Toledo earned his degree in marketing and advertising and thereafter had a long career in the heating and air conditioning business, both building his own successful contracting business and later as a sales engineer He is a past president of the Toledo Heating and Air Conditioning Contractors Association and was a member of the American Society of Heating Refrigerating and Air Conditioning Engineers He lived life enthusiastically even in retirement He was active as a volunteer in his adoptive community of Plymouth Michigan He was passionate about his family, politics history and sports He will be truly missed by those whose lives he touched especially his grandchildren with whom he formed a special bond. A memorial mass will be held at St. Thomas the Apostle Catholic Church 530 Elizabeth St. Ann Arbor on Saturday December 3 at 10:30 a.m. Contributions may be made to either the National Coalition for Homeless Veterans 333 1/2 Pennsylvania Avenue SE Washington DC 20003 1148 or to The St. Thomas the Apostle Heritage Fund, 530 Elizabeth St. Ann Arbor

NICHOLAS R. DIANA

Age 24 November 25 2005 Beloved son of Michael and Debra Dear brother of Tony and Mike Grandson of Myrna and the late Richard Hersh Nephew of Janet (Kirk) Turkish Julie, Ron and Dale (Jenne) Hersh Cousin of Marisa and Kyle Turkish Visitation Thursday 2:00pm at The John N. Santeu & Son Funeral Home 1139 Inkster (between Ford Rd and Cherry Hill) in state Friday 9:00am until a 10am Mass at St. Dunstan Catholic Church 1515 Belton (two blocks west of Inkster 2 blocks south of Ford Rd.)



LUCIUS C. TRIPP, M.D.

November 28 2005 Age 63 Beloved husband of Delores Father of Felicia L. Tripp Brother of Mary Olive Betty Houston Luke Tripp Jr. James Tripp Richard Tripp Bridg Hudson Judy Smith, Herbert Tripp, and Fred Tripp Memorial service Friday 6:00pm, at The Detroit Yacht Club 1 Riverbank Dr. Belle Isle, Detroit In lieu of flowers family suggests memorial tributes to The Old Newsboys Goodfellow Fund, P.O. Box 44444, Detroit, MI 48244 0444 For information, call A.J. Desmond & Sons (248) 549 0500 View obituary and share memories at www.DesmondFuneralHome.com

MARY ANN BRICKER

Age 55 Passed away November 27 2005 Formerly of Bloomfield Village Attended Stephens College Mary Ann was a member of Northbrook Presbyterian Church D. A. R. Village Club Survive by Daughter Sally Lynn Bricker of R.O. Son Edward John Bricker of Clawson Two Sisters Nancy (David Siebert) Eaton of Beverly Hills and Sally (Henry) Schott of Salt Point New York One brother, Charles L. (Susan) Bricker, Jr. of Plymouth MI Also Nieces and Nephews Daughter of the late Charles and Eleanor Bricker Funeral Services will be held at Wm R. Hamilton Co. 820 E. Maple Birmingham at 11:00 A.M. Thursday December 1 2005 Visitation was held Wednesday from 2 to 4 and 6 to 8 p.m. Entombment to follow in Woodlawn Cemetery Mausoleum Detroit Officiated by Reverend Peter T. Moore, Pastor Southfield Presbyterian Church Memorial tributes may be made to Royal Oak Animal Shelter, 1515 Edgeworth, Royal Oak, Michigan 48067

MARY ANN OPALINSKI

Age 83 passed on peacefully at home after a courageous battle with pancreatic cancer She was surrounded by her family and left her arms to be with the Lord on Monday morning November 21 2005 She was the devoted wife of Ted, for over 61 years loving mother of Carol (Steve) Lawrence Ken (Diane) Opalinski and Bob (Darlene) Opalinski dearest grandmother of Jill Lawrence Matthew (Jacque) Lawrence Jeff Ryan and Brian Opalinski, great grandmother of Austin and Kaitlynn Lawrence and loving sister of Michael (Barbara) Wolnick A memorial Mass of the resurrection will be held at 11:00 a.m. on Saturday Dec. 3, 2005, at St. Maurice Catholic Church Livonia Visitation with family and friends begins at 10:00 in the church hall In lieu of flowers, memorial contributions may be sent to the Father Solanus Guild, Capuchin Soup Kitchen, or Angela Hospice Please share a memory with the family at www.vermeulenfuneralhome.com

NANCY H. MORRISON

Of Birmingham passed away November 26 2005 Wife of the late William S. Morrison Mother of Julie, Bradley and Laure Grandmother of Callie and Ryan Wnuk Joshua and Courtney Morrison Daughter of the late Lawrence & Harriet Howe Memorial service Christ Church Cranbrook Bloomfield Hills Friday December 2 2005 at 1:00 PM In lieu of flower tributes to charity of choice

May You Find Comfort in Family & Friends

Your Invitation To Worship

BAPTIST

NEW HOPE BAPTIST CHURCH
33640 Michigan Ave • Wayne MI
(Between Wayne Rd & Merriman Rd)
(734) 728-2180
Virgil Humes, Pastor

Saturday Evening Worship 6:00 p.m.
Sunday Worship 7:45 a.m. and 10:45 a.m. Sunday School 9:30 a.m.
Wednesday Prayer Service 6:00 p.m. Wednesday Children, Youth and Adult Bible Study 7:00 & 8:00 p.m.



UNITED METHODIST

Clarenceville United Methodist
20300 Middlebelt Rd • Livonia
474 3444
Pastor James E. Britt
Worship Services 8:45 & 11:15 AM
Sunday Eve Bible Study 6:00 PM
Nursery Provided
Sunday School 10 AM

ST. MATTHEW'S UNITED METHODIST
30900 S. Middlebelt Rd (Bet. Merriman & Middlebelt)
Rev. Mary Margaret Eckhardt, Pastor
9:30 a.m. Sunday School
10:30 a.m. Worship
www.gbgn.umc.org stmatthews_von_a
Nursery Provided • 734-422-6038

LUTHERAN CHURCH MISSOURI SYNOD

Christ Our Savior Lutheran Church
14175 Farmington Road Livonia a Just north of I 96
734-522-6830

Sunday Worship 8:15 & 11:00 am Traditional
9:45 Modern

Sunday School 9:45 & 11 am
Early Childhood Center
Phone 734 513 8413

Making disciples who share the love of Jesus Christ
Rev. Luther A. Werth, Senior Pastor & Rev. Robert Bayer, Assistant Pastor



Canton Christian Fellowship

Pastor David Washington and The CCF Family would like to invite you to

"Where the Word is Relevant, People are Loved and Christ is the Key"

Join us for Worship Service at 10:30am
Sunday School and/or New Members Orientation 9:00am
Located at 6500 N Wayne Rd • Westland, MI
Between Ford Road and Warren Road
Inside Good Shepherd Church
734-721-9322

It's not about Religion it's about Relationships
Come to a place where lives are changed, families are made whole and ministry is real!



"More than Sunday Services"

9:00 and 11:00 a.m. Worship Service

- Dynamic Youth and Children's Programs
- Excellent Music Ministries
- Small Groups For Every Age
- Outreach Opportunities

Pastor Dr. Dean Klump
Associate Pastor Rev. Jeremy Africa

First United Methodist Church of Plymouth
95201 North Territorial Road (West of Sheldon Road)
(734) 453-5280
www.pfumc.org

NEWBURG UNITED METHODIST CHURCH
Open Hearts, Minds & Doors
36500 Ann Arbor Trail between Wayne & Newburgh Rds
734-422-0149

Worship Service and Sunday School 9:15 & 11:00 a.m.
Rev. Barbara E. Welbaum
visit our website www.newburgumc.org

GRACE LUTHERAN CHURCH MISSOURI SYNOD
25630 GRAND RIVER at BEECH DALY
313-632-2266 REDFORD TWP

Worship Service 9:15 & 11:00 A.M.
Sunday School 9:15 & 11:00 A.M.
Nursery Provided

The Rev. Timothy P. Helboth, Senior Pastor
The Rev. Dr. Victor F. Helboth, Assistant Pastor

HOSANNA-TABOR LUTHERAN CHURCH & SCHOOL
9800 Laverne • So. Redford • 313 937 2424
Rev. Jonathan Mano, S. Pastor
Dr. Steve Eggers, Assoc. Pastor

Sunday Morning Worship 8:30 & 11:00 a.m.
Education Hour 9:45 a.m.
Ch. s an School
P e K nide garden 8 h G ade
Fo mo e info mat on ca
313 937 2233

CATHOLIC

Tridentine Latin Mass
Approved by the Archdiocese of Detroit
Every Sunday at 9:30 AM

Sunday, October 31
Music Program.
Byrd, Mass for Four Voices
Benediction Following Mass

Discover the solemnity and majesty of the Traditional Rite of the Roman Catholic Church in one of Detroit's architectural masterpieces

St. Josaphat Church
691 E Canfield Ave
On the West I 75 Service Drive
Between Warren and Mack
(313) 831 6659
www.stjosaphatchurch.org

CHURCH OF CHRIST

CHURCH of CHRIST WEST
291 East Spring Street • Plymouth 48170

Sunday Worship • 11am & 6pm
Bible Class
Sunday 10am & Wednesday 7pm

734-451-1877 Michigan Bible School
Minister Tuesday & Thursday 7pm
John Natuo www.churchofchristwest.org

Aldersgate United Methodist
10000 Beech Daly

9:30 a.m. Traditional Worship
9:30 a.m. Sun School all ages
11:00 a.m. Cont. Family Worship
www.aldersgatemi.org

PRESBYTERIAN (U.S.A.)

Worship in Downtown Plymouth
First Presbyterian Church
Main & Church Streets - (734) 453-0464
8:30 9:30 & 11:00 AM
visit us at www.fpcpn.org

Risen Christ Lutheran
David Martin, Pastor
46250 Ann Arbor Road • Plymouth
(1 Mile West of Sheldon)
(734) 453 5252

Sunday Worship 8:15 & 10:45 a.m.
Sunday School (Children & Adults) 9:30 a.m.
All are Welcome Come as you are!
www.risenchrist.net

St. Matthew Lutheran Church & School
5885 N. Venable Rd. Westland • (734) 425 0260
Pastor K. E. Lambert, Pastor Phil A. Poole

Traditional Worship p. Sunday 8:00 & 11:00 a.m.
Bible Study & Sunday School 9:30 a.m.
Contemporary Worship p. 1st Sunday of every month 11:00 a.m.
Monday Night Service at 7:00 p.m.
N. on a y. Acc. ed. ed. Ch. s an School
P e 8 h G ade • Ca (734) 425 0261

NON DENOMINATIONAL

UNITED CHURCH OF CHRIST

NATIVITY UNITED CHURCH OF CHRIST
9435 Henry Ruff at West Chicago
Livonia 48150 • 421-5406
Rev. Larry Hoxey, Pastor
10:30 a.m. Worship Service
and Youth Classes
Nursery Care Available
WELCOME

BELL CREEK COMMUNITY CHURCH
Casual, Contemporary, Excellent Children's Program

Meets at Franklin H.S. in Livonia on Joy Road (Between Main and Middlebelt Roads) at 10:00 a.m.
734 425 1174
Join us for coffee, bagels and donuts after the service!

Rosedale Gardens Presbyterian Church (USA)
9601 Hubbard at W. Chicago Livonia MI
(Between Main and Farmington Rds)
(734) 422-0494
www.rosedalegardens.org

Contemporary Service 9:00 am
Traditional Service 10:30 am

Nursery Care Provided
We Welcome You To A Full Program Church
Rev. Richard Peters, Pastor
Rev. Kelli Bohman, Assoc. Pastor

EVANGELICAL LUTHERAN CHURCH IN AMERICA

Timothy Lutheran Church
A Reconciling in Christ Congregation
8820 Wayne Rd (Between Ann Arbor Trail & Joy Road)
Livonia • 427-2290
Jill Hegdal, Pastor
10:00 a.m. Family Worship (Nursery Available)

EVANGELICAL COVENANT

FAITH COVENANT CHURCH
4 M E R N D U K I N G O H I L L S
(248) 661-9191

Sunday Worship and Children's Church
9:15 a.m. Contemporary
11:00 a.m. Traditional
Child Care provided for all services
You G o u p s • Ad l t S m a G r o u p s

ST ANNE'S ROMAN CATHOLIC CHURCH
Immemorial Latin Mass
Approved by Pope St. Pius V in 1570
St. Anne's Academy - Grades K-8
23310 Joy Road • Redford Michigan
5 Blocks E of Telegraph • (313) 534 2121

Mass Schedule
First Fri 7:00 p.m.
First Sat 11:00 a.m.
Sun Masses 7:30 & 9:30 a.m.
Confessions Heard Prior to Each Mass
Mother of Perpetual Help Devotions
Tuesdays at 7:00 P.M.

CHRISTIAN SCIENCE

First Church of Christ, Scientist Plymouth
1100 W Ann Arbor Trail, Plymouth, MI
734-453-0970

Sunday Service 10:30 a.m.
Sunday School 10:30 a.m.
Wed. Evening Testimony Meeting 7:30 p.m.
Reading Room 550 South Main
Monday-Saturday 10:00 a.m. - 2:00 p.m.
734-453-1676

LOOKING FOR A CHURCH WHERE...

- There's a commitment to truth!
- There's authentic, contemporary worship!
- People are loved regardless of race, age or background!
- There's an incredible kids ministry!

HARVEST
Meets at Michigan Theological Seminary
Plymouth, MI
On Ann Arbor Trail between Eggenry and Lilly Rds

Sunday Service Time
10:30 am
734 459-7795
www.myharvestbible.org

St. James Presbyterian Church, USA
25350 West Six Mile Rd
Redford (313) 534 7730

Sunday Worship Service 10:00 A.M.
Sunday School 11:15 A.M.
Thursday Dinners 8:00 P.M.
Nursery Care Provided • Hand capped Access b e
Rev Paul S. Bousquette

HOLY CROSS Evangelical Lutheran Church
http://holycrosslv.com

Diane Runestad, Pastor
Nursery at Both Services
Handicapped Accessible
Sunday School 9:30 a.m.

(734) 427-1414 • 3850 S. ARDEN RD., LIVINGSTON
VISITORS WELCOME (1/2 Mile West of Middlebelt)

CHURCHES OF THE NAZARENE

PLYMOUTH CHURCH OF THE NAZARENE
48901 W Ann Arbor Road (734) 453 1525

Sunday School 9:45 A.M.
Sunday Worship 8:30 & 11:00 A.M.
Sunday Evening 6:00 P.M.
Family Night Wed 7:00 P.M.
NEW HORIZONS FOR CHILDREN
453 3196

RESURRECTION CATHOLIC CHURCH
46755 Warren Rd. Canton Michigan 48187
451-0444
REV RICHARD A PERFETTO

Weekday Masses
Tuesday & Friday 8:30 a.m.
Saturday 4:30 p.m.
Sunday - 8:30 & 10:30 a.m.

EVANGELICAL PRESBYTERIAN

WARD
Evangelical Presbyterian Church

40000 Six Mile Road
"just west of I-275"
Northville, MI
248-374-7400

Dr. James N. McGuire, Pastor

Traditional Worship 9:00 & 10:20 A.M.
Contemporary Worship 11:40 A.M.

Nursery & Sunday School During All Morning Worship Services
Evening Service • 7:00 P.M.
Services Broadcast 11:00 A.M. Sunday
WMUZ 580 AM
For additional information visit
www.wardchurch.org

JEWISH

CONGREGATION BEIT KODESH

1-248-477-8974
31840 W Seven Mile Rd Livonia
Rekindle your Jewish roots with us

Friday Night Services 8:00 pm
Saturday Services 9:00 am
Sunday School 9:30 am Sept-May
www.beitkodesh.org

LUTHERAN CHURCH WISCONSIN SYNOD

St. Paul's Ev Lutheran Church & School
17810 Farmington Road
Livonia • (734) 261 1380

SUNDAY WORSHIP SERVICES
8:30 A.M. & 11:00 A.M.
PASTOR JAMES HOFF
PASTOR ERIC STEINBRENNER

EPISCOPAL

ST. ANDREW'S EPISCOPAL CHURCH
16360 Hubbard Road
Livonia Michigan 48154
734-421-8451

Wednesday 9:00 A.M. Holy Eucha st
Wed Sept May 8:00 P.M. Dinner & Classes
Saturday 6:00 P.M. Holy Eucha st
Sunday 7:45 & 10:00 A.M. Holy Eucha st
Sun (Sept-May) 10:00 A.M. Sunday School

Sunday Morning Nursery Care Available
www.standrewschurch.net

The Rev. C. Allen Kannappell, Rector

Come Worship With Us
St. John's Episcopal Church
555 S Wayne Road • Westland
734-721-5023

Sun 8:30 & 10:30 am • Sun School 10:15 am
Wed Service 10:00 am

CHURCH OF GOD IN CHRIST

Power of the Word Worship Center
Church of God in Christ



Detroit - 4801 Oakman Blvd.
Sunday Services: 8:30 am & 10:30 am

Dr. Alfred D. Knight Jr. Senior Pastor
24 Hour Prayer Line 313-935-7729
www.powerofthewordcogic.org

For Church Directory changes and information regarding advertising in this directory, please call Donna Hart (734) 953-2153 the Friday before publication.

To mail copy: The Observer & Eccentric Newspapers, 36251 Schoolcraft, Livonia, MI 48150 or Fax to (734) 953-2121



Focus on Wine

Ray and Eleanor Heald

Enjoy outstanding sparkling wine from Michigan

As the holidays approach, you'll probably want to lay away some sparkling wine to highlight your celebration with family and friends. This year, consider the sparklers of L. Mawby, Suttons Bay, Mich. You won't be disappointed.

We've tasted Larry Mawby's sparkling wines in blind comparison with French champagne and they compete favorably with the big guys, but at better prices.

Mawby crafts his wines by the same method as the French, but his best wine, Tahsmøn Brut, is \$27 compared to at least \$35 for an entry level French version.

SPARKLING DECISIONS

Mawby is a farmer, a wine-grower, a vintner who grows and hand harvests his fruit to make small lots of handcrafted wines while paying close attention to every detail. Each of his wines expresses the character of the soil and climate in which they are grown.

Beginning in 1978, Mawby made every wine imaginable from red to white, dry and sweet. In 1984, he began to make sparkling wine by the champagne method, now known as Methode Traditionelle, following a recent agreement between the U.S. and the European Economic Community.

We remember when Mawby decided to imitate the French Nouveau Beaujolais, a red wine made from the gamay grape and released the week before Thanksgiving. His wine was called Turkey Red but it was made from grapes other than gamay. "Back then, I was one of just a few winemakers on the Leelanau Peninsula trying to attract consumers with a variety of tastes," Mawby said.

"Today there are 20 wineries in this region, which means I can specialize. Consumers come to see me if they like sparkling wines because they know that's all I do. If they don't care for sparkling wines, there are 19 other wineries glad to have them visit."

Mawby chose to make only sparklers because that's what he did best. He makes sparkling wines for the same reason the Champenoise do. In their climate, grapes don't always ripen completely. This is an advantage when it comes to sparkling wines because they require high acid grapes and that is exactly what one gets with grapes harvested at low sugar.

THREE TIERS

Mawby grows 12 acres of chardonnay, pinot noir, pinot gris, pinot meunier, seyval and vignoles. His estate wines are so popular that he plans to expand his vineyards over the next few years. Estate wines are Tahsmøn Brut (\$27) toasty, full-bodied, flavorful and Cremant Brut (\$22) distinctive flavor with notes of clove, cinnamon and apricot.

Peninsular Selections from Mawby include some grapes purchased from other Leelanau growers. They include Blanc de Blanc Brut.

PLEASE SEE MICHIGAN, B10



PHOTOS COURTESY OF WENDY ROSE BICE

Detroit's largest Greek salad consists of 168 heads of lettuce, 60 pounds of feta cheese, 4 gallons of pepperoncini, 3 gallons of olives, two cases of chickpeas, two cases of beets, four cases tomatoes, two cases cucumbers and 9 gallons of dressing.

Giving back

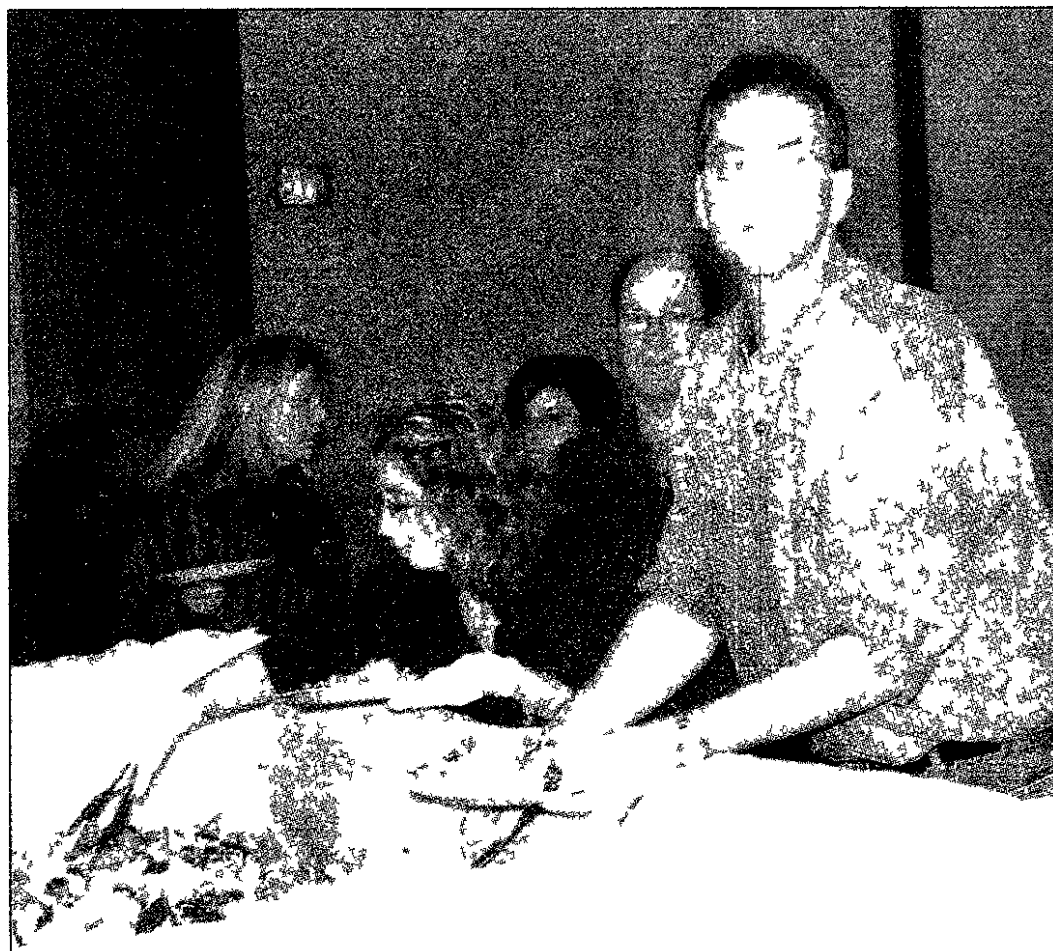

Gary Bice, chairperson of Detroit's Largest Greek Salad, serves up a bowl at the 2004 event, which raises funds for Children's Hospital.

What: Detroit's Largest Greek Salad, a fund-raiser to purchase Beanie Babies for Children's Hospital of Michigan in Detroit.
When: Noon-3 p.m. Sunday, Dec. 4.
Where: Temple Beth El, northwest corner of 14 Mile Road and Telegraph in Bloomfield Hills.
Tickets: \$5 for a bowl of salad and drink. Pre-paid tickets available from any Leo's Coney Island or Temple Beth El or at the door the day of the event.



Chelsea Rosenbaum, Erin Greenberger, Abby Bice and Brian Schulte serve bowls of salad to guests at the 2004 Detroit's Largest Greek Salad to benefit Children's Hospital. Some 400 salads were served at the event last year. This year, organizers hope to top 500.

PLEASE SEE SALAD, B10

Detroit's largest Greek salad tossed at fund-raiser

BY KEN ABRAMCZYK
STAFF WRITER

Six years ago Abby Bice became ill. Abby stayed for five days at an area hospital, where doctors had difficulty diagnosing her symptoms and she became gravely ill, her mother Wendy remembers. Once Abby transferred to Children's Hospital, she was diagnosed, treated and released after three days.

Today she is healthy and she's giving back to the hospital that helped her so much.

Abby and her mother have organized "Building Detroit's Largest Greek Salad" for a second year after raising more than \$4,000 last year toward the purchase of Beanie Babies for the hospital. Wendy's husband Gary, and children Jacob and Emily also help with the event.

Last year Abby wanted to ask Leo Stassinopolus, owner of Leo's Coney Island (and Abby's favorite restaurant), to donate salads as part of a fund-raiser. "I said, 'Why not ask him to build Detroit's Largest Greek Salad?'" Wendy said. Abby always orders Greek salad from Leo's.

After Stassinopolus agreed to help and Temple Beth El donated the space, organizers and volunteers sold 400 salads last year with enough money raised to purchase an entire year's worth of new Beanie Babies.

That went so well that the event - Building Detroit's Largest Greek Salad - has been scheduled again this year for noon to 3 p.m. on Sunday, Dec. 4, at Temple Beth El in Bloomfield Hills. Organizers hope to sell 500 salads this year.

Last year's salad required 168 heads of lettuce, 60 pounds of feta cheese, 4 gallons of pepperoncini, 3

Simple sauté saves time during holidays

For many families, a holiday celebration wouldn't be complete without an extravagant and filling feast, but holiday meals don't have to be elaborate to be festive and satisfying.

With a comfort food menu and wholesome seasonal ingredients, you can enliven holiday dishes and add a dash of nutrition without straying too far from family favorites.

This year, try a little olive oil to give traditional holiday dishes a makeover. Using olive oil in place of harmful saturated fats

gives your dishes a dose of heart-healthy monounsaturated fats without sacrificing taste.

Recognized in 2004 by the Food and Drug Administration as heart healthy, olive oil contains more monounsaturated or "good" fat per tablespoon than butter, margarine and all other cooking or salad oils.

"Using olive oil in place of butter or other cooking oils and spreads in traditional dishes adds flavor and health benefits," said Bob



NORTH AMERICAN OLIVE OIL ASSOCIATION

Sesame-Almond Vegetable Sauté is an easy side dish that can be prepared on the stovetop in less than 30 minutes.

PLEASE SEE SESAME, B10

Side dish

Book signing

Brian Polcyn, certified executive chef and owner of Five Lakes Grill in Milford, and author Michael Ruhlman will be on hand Tuesday, Dec. 6, to sign copies of their new book, *Charcuterie: The Craft of Salting, Smoking and Curing*.

A comprehensive book on the subject of preserving meats, Polcyn, who is also a charcuterie instructor at Schoolcraft College, and Ruhlman connect the ancient art to our early ancestors and create recipes that are adapted to the modern kitchen.

The signing will take place in the American Harvest Restaurant in the VisTaTech Center on the Livonia campus from 2:30 p.m. to 4:30 p.m. There will be refreshments prepared by Polcyn, including examples of charcuterie and hors d'oeuvres.

Copies of the cookbook are available in the college bookstore for \$22.50. The Culinary Arts Department requests that persons who plan to attend call to make a reservation at (734) 462-4423.

Win tickets

Win tickets to Super Bowl XL by filling out an entry form at any Big Boy restaurant in Michigan.

The prize includes Super Bowl XL tickets, round trip air or ground transportation for two, four nights in a hotel, two invitations to the Diet Pepsi Super Bowl party, two tickets to the NFL Experience at Cobo Center and \$250 in spending money and two gift bags.

A drawing to select the winner will be held on Dec. 26. Entry forms must be postmarked by Dec. 17.

For details, visit any Big Boy restaurant or go to www.bigboy.com.

Spice it up

Add a little spice to life this fall with Krispy Kreme's pumpkin spice doughnuts.

The popular flavor is back, in both doughnuts and doughnut holes this year. They are available now through Jan. 29 in participating stores.

Warm up as the weather cools down with this delicious, old-fashioned cake doughnut flavored with pumpkin and spices.

To find the nearest store, visit www.krispykreme.com/storelocator.

Food site

A new database will answer the question, "What's in your food?"

This database allows users to view a 60-nutrient profile for each of more than 13,000 foods.

Launched by the U.S. Department of Agriculture's Agricultural Research Service (ARS), the new resource is called "What's in the Food You Eat - Search Tool."

The database can be a tool for nutrition and health professionals and help consumers make informed decisions about food choices.

Free access to the ARS nutrient information database on thousands of foods typically eaten in the United States can be found at <http://www.ars.usda.gov/Services/docs.htm?docid=7783>.

Try baking sticky buns overnight

BY THE CULINARY INSTITUTE OF AMERICA FOR AP WEEKLY FEATURES

HYDE PARK, N.Y. (AP) — Why spend all morning in the kitchen making homemade sticky buns, when you can mix the dough and shape the rolls the day before?

In addition to offering a convenient alternative when you have overnight guests or early breakfast plans, the slow rise of the dough in the refrigerator makes the already mouth-watering buns even more moist, tender and flavorful.

Overnight sticky buns are made exactly like those baked the same day. The only difference is that the prepared rolls are stored in the refrigerator up to 24 hours before baking.

Just remove the pan from the refrigerator the next morning and allow the buns to warm to room temperature — depending on the temperature of your kitchen, this can take anywhere from one to two hours.

There's another way to streamline the production of sticky buns to satisfy sudden sweet cravings or unexpected guests.

Marc Haymon, lecturing instructor in baking and pastry arts at The Culinary Institute of America, suggests, "Freeze the prepared rolls instead of placing them in the refrigerator overnight. Stored in airtight containers between sheets of waxed paper, unbaked sticky buns will retain their quality for about one month."

"The day before you'd like to serve them, place the frozen rolls in prepared pans, store in the refrigerator to thaw, and bring them up to room temperature the following morning before baking."

The following recipe is from The Culinary Institute of America's *Breakfasts and Brunches* cookbook (Lebhar-Freidman, 2005, \$35).

Note: A candy thermometer is essential for preparation.

STICKY BUNS WITH PECANS

2 1/4 teaspoons active dry yeast
3/4 cup milk, warmed to 110

degrees Fahrenheit
4 cups bread flour
1/4 cup sugar
1/4 cup butter, softened
2 large eggs, lightly beaten
1 teaspoon salt
Egg wash (1 egg whisked with 2 tablespoons cream or milk)
1/2 cup pecans
2 cups Pan Smear (recipe follows)
1 cup Cinnamon Smear (recipe follows)

Place the yeast and warm milk in the bowl of a mixer and stir to dissolve, let stand about 5 minutes. Combine 2-1/2 cups of the flour with the sugar, butter, eggs and salt. Mix on low speed using the dough hook just until the dough comes together. Add as much of the remaining flour to the mixture as needed so dough is no longer sticky. Increase speed to medium-high and mix until dough is soft, smooth and elastic, about 5 minutes.

Shape dough into a ball and place in a lightly greased bowl. Cover with plastic wrap and let dough rise in a warm place until doubled in size, about 2 hours. Fold the dough gently over on itself in three or four places. Cover and let rise until doubled, about 1 hour. While dough rises, toast and chop the pecans and set aside. Prepare Pan Smear and Cinnamon Smear, and set aside.

Preheat oven to 400 degrees Fahrenheit. Prepare two 9-inch square baking pans by pouring 1 cup Pan Smear into each of them, sprinkle with the toasted, chopped pecans. Roll dough into a rectangle 8 by 14 inches and about 1/2-inch thick. Dust dough and rolling pin with flour to prevent dough from sticking. Brush a 1-inch-wide strip of egg wash along the long side of the dough closest to you. Spread the Cinnamon Smear evenly over the remaining dough. Roll the dough to form a log, starting with the edge opposite the egg-washed strip. Pinch the dough together to seal the seam. Slice into 12 equal pieces.

Place 6 rolls in each of the prepared pans. (You can refrigerate the rolls at this point for up to 24 hours, or freeze up to 1 month.) Cover the rolls and let them rise until they have nearly doubled, about 30 minutes. Brush lightly

with egg wash.

If sticky buns have been prepared in advance, remove them from the refrigerator and allow them to warm to 100-degree temperature before baking. Bake rolls until baked through and crust is golden brown, about 30 minutes. As soon as you remove the pans from the oven, turn each pan over onto a plate. Lift the pan away and cool rolls before serving.

Makes 12 sticky buns

Nutrition information per bun: 470 cal., 9 g. pro., 79 g. carbo., 15 g. fat, 280 mg. sodium, 40 mg. chol., 2 g. fiber

PAN SMEAR

1 cup light brown sugar
3/4 cup dark corn syrup
1 cup heavy cream

(Note: A candy thermometer is essential for preparation.)

Combine the brown sugar, corn syrup and heavy cream in a saucepan and heat to 220 degrees Fahrenheit, stirring frequently to prevent scorching. Cool to room temperature before using. (The smear will be caramel colored and syrupy.)

Makes 2 cups

CINNAMON SMEAR

1/2 cup bread flour
1/2 cup sugar
2 teaspoons ground cinnamon
3 tablespoons butter
3 large egg whites

Mix together flour, sugar and cinnamon in the bowl of a mixer. Add the butter. Using the paddle attachment, mix on medium speed for 1 minute, or until it looks like coarse meal and there are no visible chunks of butter.

With the mixer on medium speed, add the egg whites one at a time. Continue to mix until fully combined, scraping down the bowl as necessary. (The smear will be a kind of granular paste.)

Makes 1 cup

The recipes and more than 175 others are explained and illustrated in The Culinary Institute of America's *Breakfasts and Brunches* cookbook available at bookstores nationwide or at <http://www2.ciachef.edu/lm/erthustasiats/cookbooks.htm>

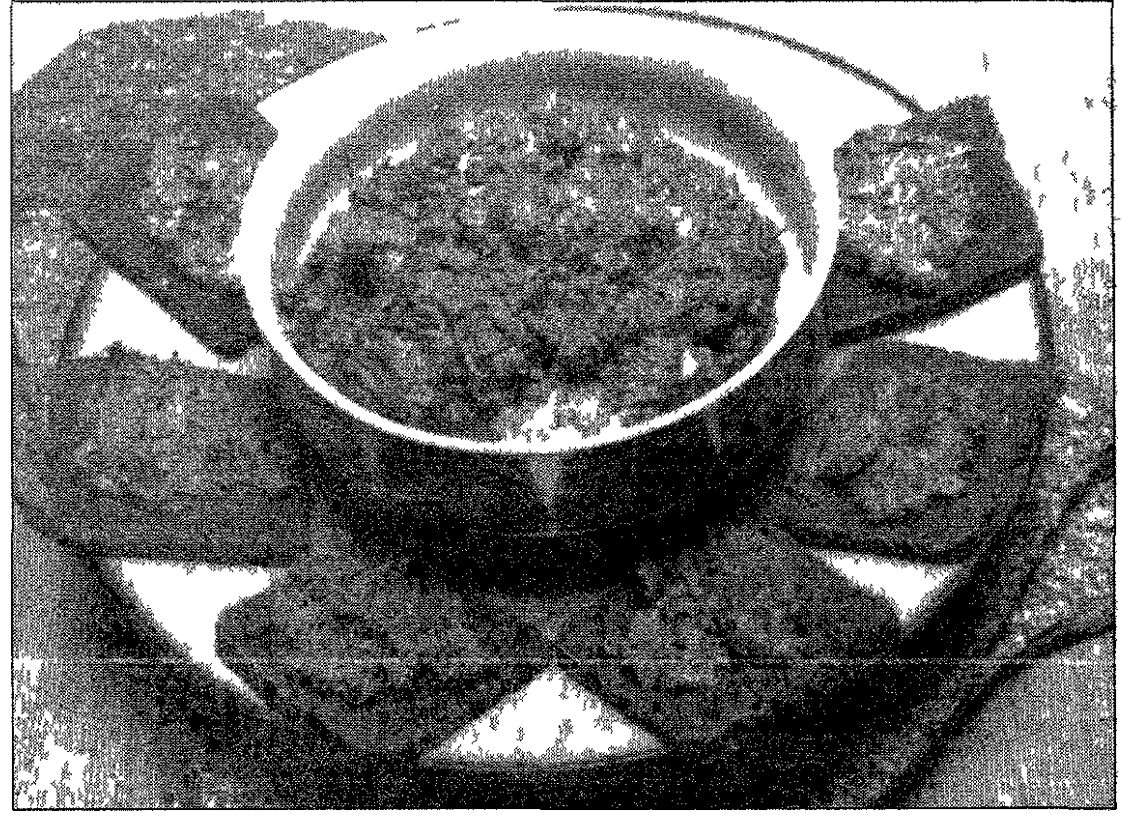

AMERICAN INSTITUTE FOR CANCER RESEARCH

Dishes featuring wild mushrooms are perfect for the holidays or when entertaining.

Go wild with mushrooms

BY DANA JACOBI
AMERICAN INSTITUTE FOR CANCER RESEARCH

Wild mushrooms are perfect for enriching the flavor of dishes and making them seem extravagant. Dishes featuring wild mushrooms are perfect for the holidays or when entertaining. Their deep, meaty flavor lets you offer meatless dishes that will satisfy the taste buds of carnivores as well as vegetarians. Despite their rich flavor, they are actually lean and healthy. You can serve them as an hors d'oeuvre, soup, or side dish.

The mushrooms in the crostini below are often prepared with a technique popular with chefs — dehydrating mushrooms and grinding them into a powder — but impractical in home kitchens. You can achieve approximately the same intense flavor with a simple method, detailed in the recipe below.

Cream cheese adds further richness. The reduced-fat version has a much better taste and texture than the fat-free type, but not too many calories. For the bread, slices of a whole-grain Italian loaf, toasted or grilled, complement the mushrooms nicely.

WILD MUSHROOM CROSTINI

1/2 package (4 ounces) sliced fresh shiitake mushrooms or 6 oz. whole shiitake mushrooms, stemmed and sliced

2 packages (8 ounces) sliced cremini mushrooms or 1/4 pound whole creminis, stemmed and sliced
1/2 cup chopped shallots
2 tablespoons butter or trans fat free spread
2 tablespoons fat free reduced sodium mushroom or chicken broth
2 tablespoons fresh lemon juice
1/4 cup reduced fat cream cheese, softened at room temperature
2 tablespoons finely chopped fresh dill
Salt and freshly ground black pepper
8 thin slices whole grain bread or untoasted black bread

Preheat the oven to 250° F. Set a baking rack on a cookie sheet. Arrange the shiitake mushrooms on the rack. Bake them 20 minutes or until dry but still somewhat flexible. (The thinnest slices may be crisp.)

Transfer them to a plate and set aside to cool. (This may be done up to one day ahead, stored in a bowl, uncovered at room temperature.)

Place half the cremini mushrooms in a blender or food processor. Add the dehydrated mushrooms and the shallots. Chop the remaining mushrooms and add to the blender. Pulse until finely chopped and moist.

Melt the butter/spread in a medium skillet over medium-high heat. Add the mushroom mixture. Sauté until the mushrooms release their liquid, 5 to 7 minutes. Stir in the broth and lemon juice. Cook stirring occasionally, until the liquid has evaporated and the mushrooms form a mass, about 15 minutes.

Transfer the mixture to a mixing bowl. Mix in the cream cheese and dill with a fork until well combined. Season to taste with salt and pepper. Cool the pâté before using. (The spread keeps up to 3 days, tightly covered in the refrigerator.)

To serve, bring the spread to room temperature, toast or grill the bread (leave black bread untoasted) and liberally spread them with the pâté.

Makes 16 servings (1/2 slice bread and 2 tablespoons pâté each)

Per serving: 74 calories, 3 g. total fat (1 g. saturated fat), 9 g. carbohydrate, 4 g. protein, 2 g. dietary fiber, 106 mg. sodium

Dana Jacobi is author of *The Joy of Soy* and recipe creator for the American Institute for Cancer Research.

Warm and fruity breakfast is easy fix

BY THE ASSOCIATED PRESS

Defeat the shivers and face cold mornings with breakfast bravado!

The following variation of classic oatmeal is so easy to make, the first effect will be a smug glow of satisfaction. The follow-up sensation of well-being will last on through the morning — as we all

know, that's one of the benefits of getting a nutritious start to the day.

HEARTY OATMEAL WITH PEARS, RAISINS AND PECANS

1 Bosc pear, cored and chopped
1 cup old-fashioned oatmeal
1/2 teaspoon ground cinnamon
4 tablespoons brown sugar
1/4 cup raisins

2 cups water
1/4 cup toasted pecans

In a large glass bowl combine pear, oatmeal, cinnamon, brown sugar, raisins and water. Microwave on high for 7 minutes or until pears are tender. Divide between two bowls, top with pecans and serve warm. Makes 2 servings.

BABY, WE MADE A DIFFERENCE!



North Oakland's New NICU Made possible by YOU!

The women and men of the Auxiliary to North Oakland Medical Centers raised more than \$120,000 for the new Neonatal Intensive Care Unit (NICU) at North Oakland Medical Centers! This group of volunteers has made a difference in the fight against infant mortality. Your gift to the North Oakland Foundation for our NICU fund will help keep our area's tiniest and most vulnerable citizens safe and healthy, saving precious lives.

Get Involved. Join us to save an infant's life.

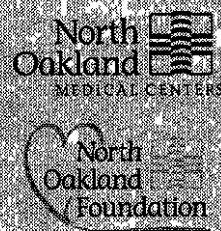
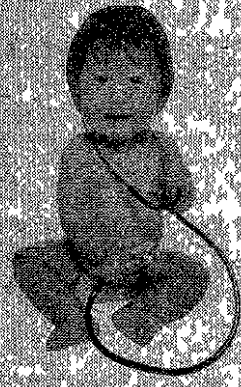

The North Oakland Foundation at North Oakland Medical Centers. A partnership to spread Health and Hope in our Community.

I'd like to help save an infant's life!

CONTACT INFORMATION

Name _____
Address _____
City _____ State _____ Zip _____
Phone (____) _____ Email _____

I've filled out the above information but would prefer my gift to remain anonymous.

PAYMENT INFORMATION

I have enclosed a check in the amount of \$ _____ payable to the North Oakland Foundation.

Please charge \$ _____ to my Visa MC AMEX

Name on card _____

Credit card Number _____

Exp. Date _____ Signature _____

Billing address (if different) _____

Mail to 461 West Huron Pontiac MI 48341
Fax to 248-857 7086
Phone 248-857 7096
Email foundation@nomc.org
www.northoaklandfoundation.org

POF020326309

Your donation provides me with shelter from the cold.

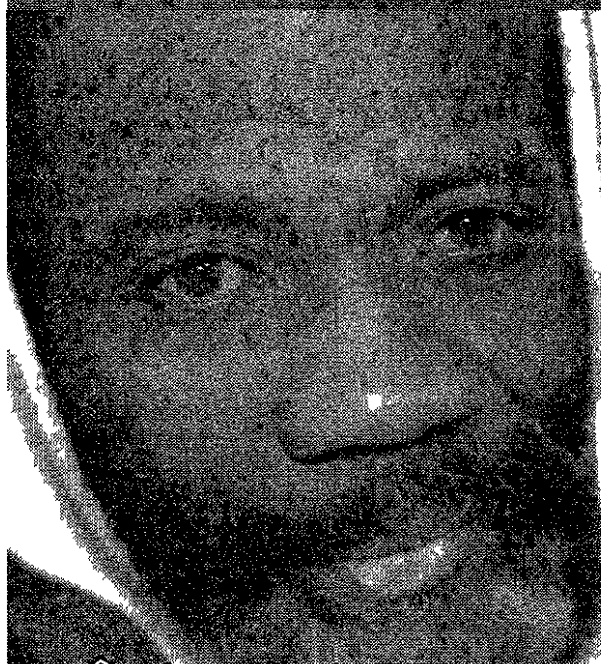

With your support, The Salvation Army feeds and shelters the homeless — and so much more. Thousands of Metro Detroiters face poverty every day. Let's make change happen right here at home.

MAKE Change HAPPEN



1-877-SAL-MICH

Donate at any LaSalle Bank or at WJR's Virtual Red Kettle at wjrc.com



Steaming gives you a break during holidays

Something steamed may be just the break you need during the holiday overeating season.

Steaming is a traditional Chinese cooking technique that uses gentle heat and no oil to cook foods. It is, therefore, a simple, convenient way to prepare low-fat, low-calorie entrées. As an added benefit during this busy season, it is a much cleaner process than stir-frying.

This cooking method also has health benefits. The Chinese diet, abundant in vegetables and just a little animal protein, mirrors the mostly plant-based diet the American Institute for Cancer Research recommends to protect against cancer and other diseases.

Steaming helps avoid overcooking and keeps vegetables crunchy and bright. And, in contrast to cooking directly in water, steaming protects water-soluble nutrients that would otherwise be leached during cooking. Steaming, therefore, results in more nutrient-rich food.

A deep saucepan, Dutch oven, pressure cooker, roasting pan, or wok all can be used for steaming food. The pot should be wide enough to hold a heat-proof plate that comfortably contains the ingredients in one layer, and elevated with a space of at least one inch between the plate and the water, which allows steam to circulate evenly around the food.

The plate of food can be set on any kind of heat-proof stand or rack that will keep it stable and high enough to prevent the water from splashing onto the food. The earthy, smoky flavor of Chinese dried mushrooms and black beans provides a full-bodied complement to the delicate taste of seafood in the following steamed dish.



AMERICAN INSTITUTE FOR CANCER RESEARCH

The earthy, smoky flavor of Chinese dried mushrooms and black beans provides a full-bodied complement to the delicate taste of seafood in the following steamed dish.

STEAMED FISH AND VEGETABLES

- 2 teaspoons fermented black beans*
- 1/2 teaspoon grated peeled fresh ginger
- 1/4 teaspoon grated garlic
- 1 tablespoon sesame seed oil divided
- 12 ounces (3/4 pounds) fillet of white fish scallops or shelled and deveined shrimp
- 24 small dried Oriental mushrooms (about 1 1/2 cups)
- 4 large scallions including green tops
- Salt and white pepper
- 3 cups cooked brown rice

In a small cup, mash beans with ginger, garlic and half the oil. Rub into surface of fish and set aside 10 to 20 minutes to marinate.

Soak mushrooms in warm water until softened. Drain and gently squeeze out excess water (Soaking juice can be saved for later use in sauces or soups.) Cut away stems and discard. Cut large mushrooms so all are about the same size. Diagonally cut white part of scallions into 2-

inch lengths. Finely chop green tops to make 1/2 cup.

Place mushrooms and white scallions on plate used for steaming. Sprinkle with remaining half-tablespoon of oil. Steam until mushrooms are tender.

Add fish to plate. Sprinkle chopped scallion over all. Steam until fish is tender.

Remove from heat and serve, pouring any excess liquid over food. Season to taste with salt and pepper. Serve with cooked rice.

*Fermented black beans are usually sold in small glass bottles and found in the Chinese food section of markets or in specialty stores. As an alternative, 1 teaspoon grated, fresh peeled ginger can be used.

Makes 4 servings

Per serving: 292 calories, 5 g total fat (less than 1 g saturated fat), 37 g carbohydrate, 22 g protein, 4 g dietary fiber, 68 mg sodium

Recipe from the American Institute for Cancer Research

CALENDAR

If you have an item for the Taste calendar please submit at least two weeks prior to your event to Ken Abramczyk, Taste editor, Observer & Eccentric Newspapers, 36251 Schoolcraft, Livonia, MI 48150. e-mail: kabramczyk@oe.homecomm.net or fax: (734) 591-7279.

Cuisine du Jour

Michelle Bommarito, culinary instructor and pastry chef, discusses Appetizers and Desserts on Thursday, Dec. 8 at a hands-on culinary training session at Trevarrow, 1295 N. Opdyke Road, Auburn Hills. For information, call (248) 377-2300.

Schoolcraft classes

Enjoy the following culinary seminars at the VistaTech Center at Schoolcraft College, 18600 Haggerty (between Six and Seven Mile roads) in Livonia this fall. For more information, call Continuing Education Services at (734) 462-4448 or visit www.schoolcraft.edu.

Hands On

Note: Hands On classes have a prerequisite of the Cooking 101 Skill Development class or instructor's approval. Plan to wear a white chef's jacket, dark pants

and comfortable shoes for all hands-on classes. Please prepare a tool kit with the following: a set of knives, peeler, spatula, dough cutter, thermometer and measuring spoons. Visit Web site: www.schoolcraft.edu for more information on these classes and others. Cookie Decorating with Royal Icing: 6 p.m. Dec. 6. Live Lobsterfest: 5:30-8:30 p.m. Dec. 8. Cooking Beef Tenderloin: 5:30-8:30 p.m. Dec. 15. Holiday Appetizers: 9 a.m.-noon Saturday, Dec. 17.

Busch's

Busch's cooking classes focus on easy appetizer recipes for adding elegance to holiday entertaining. Learn Busch's favorite shortcuts and garnishes. Make simple yet elegant crostini and canapes with tenderloin and smoked salmon. Work with pastry with crab meat, avocado, stuffed gougeres and wild mushroom purses. Use frozen and shelf-stable appetizer shells for various fillings (pear, leek and Gruyere and chocolate cups with honey mas carpone mousse). Class begins at 6 p.m. Dec. 6 at 24445 Drake in Farmington.

"Still Aching From Your Car Accident?"

Westland, MI -

Car Accident injuries are often misunderstood. The pain from automobile accident injuries can last weeks, months, even years down. After an accident, many feel frustrated because they don't know how they should feel, how long it should take to get better and what they should do. A free report has recently been available to accident victims that reveals:

- ✓ A common condition that keeps many accident victims from every feeling normal again
- ✓ How to determine if you may already have this seldom discussed condition
- ✓ How to protect yourself from insurance company abuse

To get a copy of this free report, call 1-800-888-744-2225 (Toll free 24 hr recorded message)

WIDEX
High Definition Hearing

Excellent Value. Digital Performance.™

Hear How Bravissimo 100% Digital Hearing Aid Technology Is Helping People Hear Better For Less.™

- Sound Stabilizer and Microphone Noise Reduction to help provide natural and comfortable sound
- Models for people with mild to profound hearing losses
- Long battery life with low battery replacement warning



Bravissimo
Excellent Value. Digital Performance.™

PERSONALIZED HEARING CARE, Inc.
Professional Audiology Services

35337 West Warren, Westland, Michigan
#734.467.5100

SIX GENERATIONS HAVE READ THE STORY. THIS ONE WILL SING IT!

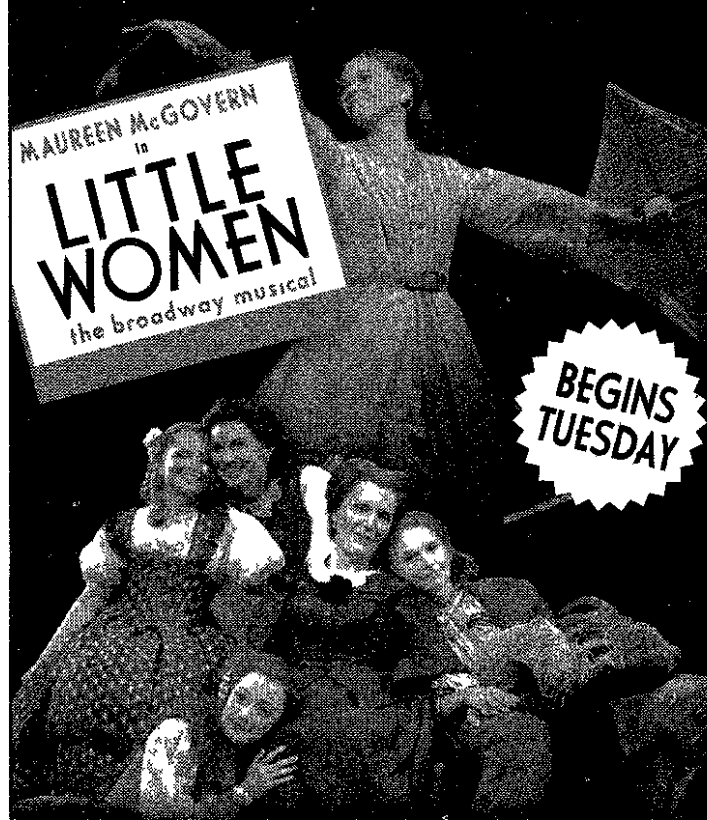

"A Broadway musical for the whole family!"
—New York Sun

"Maureen McGovern is superb!"
—Wall Street Journal

"UNBELIEVABLY BEAUTIFUL! Go see it!"
—CBS-FM Radio

Fisher Theatre • Dec. 6-18 & Dec. 27-Jan. 1
Tickets on sale at Fisher Theatre box office & all **ticketmaster** outlets inc Marshall Field's • **ticketmaster.com** • charge by-phone **248-645-6666**
Info 313-872-1000 • **NederlanderDetroit.com** • **LittleWomenOnBroadway.com**
Groups (12 or more) call weekdays 313-871-1132
6+ Signed performance for the deaf Sunday 12/11/05 6:30PM **LaSalle Bank**

Your donation gives me warm winter clothes.



With your support, The Salvation Army helps protect struggling families from the cold — and so much more. Thousands of Metro Detroiters face poverty every day. Let's make change happen right here at home.



1-877-SAL-MICH
Donate at any LaSalle Bank or at WJR's Virtual Red Kettle at **wjr.com**

A Christmas Carol

BY CHARLES DICKENS ADAPTED BY CHARLES NOLTE

November 25 ~ December 24

Thrill to the tale of mean-spirited Ebenezer Scrooge and the ghosts that haunt him, and pray that something, or someone can warm his heart in time.

DONT MISS THIS CLASSIC CHRISTMAS TALE

The Meadow Brook Theatre
248-377-3300 **www.mbttheatre.com**

MICHIGAN

FROM PAGE B7
 (\$18) with appley chardonnay fruit, crisp, fresh and delicious, Conservancy (\$22) is off-dry and Consort (\$18) slightly sweet
 The M. Lawrence Series (\$12-\$14) is produced by cuve closed (tank) fermentation from grapes purchased out of state. You will get a sense of Larry's humor just by reading the names of these wines. Us, Sex, Fizz and Redd
 Sandpiper (\$10) has gentle fruit aromas with a hint of toastiness that finishes off-dry. It's available only at the winery or ordered directly

from the winery
 If you don't plan to visit L. Mawby in Suttons Bay or cannot find these bubbles in your favorite retail shop, you can order online and have them shipped directly to your home. Michigan wineries can ship directly to you. Log on to www.lmawby.com, have your credit card ready and be able to verify your age. Case discount is 15 percent.
 Cheers!

The Healds are Contributing Editors for the internationally respected Quarterly Review of Wines and Troy residents who write about wine spirals and restaurants for the Observer & Eccentric Newspapers. Contact them by e-mail at focusonwine@aol.com

SALAD

FROM PAGE B7
 gallons of olives, two cases of chickpeas, two cases of beets, four cases of tomatoes, two cases of cucumbers and 9 gallons of dressing.
 "It is an honor to do this for the children," Stassinopolus said.
 "It's really generous of him, that he would do it for nothing," Wendy said. "It's just incredible."

The Bice family lives in Bloomfield Hills. They became involved in the Beanie Babies drive after Abby was diagnosed with Kawasaki's Disease, a rare disease where victims experience high temperatures that don't respond to treatment, rashes and swollen glands.
 The Bices were touched when they saw the economic circumstances surrounding some of the families of children hospitalized at Children's Hospital. "Abby saw that the kids around her had few toys and flowers and their families slept in the hospital room with them because it was often better than their own homes," Wendy said.

After talking with hospital staff, Wendy learned that nursing staff used Beanie Babies to ease the hurt of the IVs on the children.
 "It seems like a small thing, but those Beanies really help the kids," said Abby, an eighth-grader at Birmingham Covington School and Temple Beth El student. "We hope to see lots of people come out and help us eat the salad. For each \$5 donation, we will be able to purchase two Beanie Babies for these kids."

After Abby recovered, the Bice family showed their appreciation to Children's Hospital by donating several

dozen Beanie Babies to the hospital. The following year, Abby decided to continue the tradition and began an annual crusade to raise money for new Beanies.

In 2003, Children's Hospital asked if the family would donate the Beanies to the IV team so children needing an IV might receive a stuffed animal. In 2004, the Bices decided to make their crusade public. Last November the Bices, their friends, family and community members rolled up their sleeves and served nearly 400 Greek salads, raising more than \$4,000. Ty Incorporated, manufacturers of the Beanie Baby line of products, heard about the event and agreed to support it by matching funds raised.
 Wendy Bice emphasized that Children's Hospital does not want Beanie Babies delivered to the hospital from donors who may want to help Children's Hospital. Wendy wants them clean so they order them directly from the manufacturer (Ty Inc.). "We have a fund set up to help them."

Temple Beth El is located on the northwest corner of 14 Mile Road and Telegraph in Bloomfield Hills. Bowls of salad will require a contribution of \$5 and will include a drink.

Pre-paid tickets are available from any Leo's Coney Island or Temple Beth El. Tickets will also be available at the door.

kabramczyk@oe.homecomm.net
 (734) 953-2107

SESAME

FROM PAGE B7
 Bauer, president of the North American Olive Oil Association. "Of the cooking oils available in the grocery store, olive oil is one of the richest sources of heart-healthy monounsaturated fats, and it's naturally cholesterol-free. It also has antioxidants such as vitamin E, which promote good health, making olive oil and even more healthful choice."

Sesame-almond vegetable saute is an easy side dish that can be prepared on the stove-top in less than 30 minutes. Extra virgin olive oil is used to lightly saute a mixture of favorite autumn and winter vegetables, which are then tossed with fresh thyme and pepper. Toasted almonds and sesame seeds add hearty flavor and crunch to this colorful dish, which is sure to brighten and bring balance to any family meal or holiday table.

For more recipes or information about the North American Olive Oil Association, visit www.aboutoliveoil.org

SESAME-ALMOND VEGETABLE SAUTE

- 1/2 cup chicken broth or water
- 1/2 small (about 2 pounds) butter nut or buttercup squash, peeled, seeded and cut into 1/2-inch pieces (about 2 cups)
- 1 cup baby carrots, halved crosswise
- 2 cups broccoli florets (about 1 1/2 inches)
- 1/2 cups cauliflower florets (about

- 1/2 inches)
- 1/4 sliced almonds
- 1/4 cup extra virgin olive oil
- 1 medium onion, cut into thin wedges
- 1 clove garlic, minced
- 2 to 3 teaspoons fresh thyme leaves
- 1/2 teaspoon salt
- 1/4 teaspoon red pepper flakes
- 1 tablespoon toasted sesame seeds

In Dutch oven or large skillet, combine squash, carrots and chicken broth. Cook over medium-high heat until broth is steaming. Cover and cook three minutes. Add cauliflower and broccoli, cover and cook two to three minutes longer or just until squash is tender and broccoli is brightened. Drain and set aside.

In small skillet over medium-high heat, cook almonds 5 to 7 minutes or until light golden, stirring frequently. Remove from heat.

In very large skillet or Dutch oven, heat olive oil over medium heat. Add onion and garlic, cook and stir two to three minutes or until onion is softened. Increase heat to medium-high. Add well-drained vegetable mixture, thyme, salt and red pepper flakes. Cook and stir until hot and tender. Stir in almonds, turn into serving dish. Sprinkle with sesame seeds.

Note: Toasted sesame seeds are available in the spice section of grocery stores. To toast your own, follow the above instructions for toasting almonds, stirring frequently and watching carefully to prevent overbrowning.

Recipe courtesy of the North American Olive Oil Association

WINE PICKS

- When it comes to domestic sparklers from California, it's hard to beat **Schramsberg**. The following are your choices.
- **Mirabelle Brut (\$19)** sports green apple, tropical and fresh citrus crispness pairs with light appetizers and seafood.
 - **2001 Blanc de Noirs Brut (\$31)** with its toasted almond and spice notes pairs perfectly with caviar and smoked fish hors d'oeuvres.
 - **2001 Blanc de Blancs (\$33)** is simultaneously complex and refined. If you like oysters on the half shell, this is your bubbly to pair with them.
 - **2002 Crémant (\$35)** is off-dry (demi-sec) and a dessert-style bubbly that pairs well with crème brûlée or a wide array of spicy Asian dishes.
 - **2002 Brut Rosé (\$37)** is alive with strawberry and raspberry aromas and flavors. Try it with sushi, ahi tuna, aged cheeses or assorted fruits.
 - **1999 Reserve (\$70)** is 73 percent pinot noir. Its full body suits it to main courses, especially crab cakes.
 - **1999 J. Schram (\$80)** is 74 percent chardonnay. Its elegance is heavenly with risotto.

All wines mentioned are available in the metro-Detroit area. If a retailer does not stock a specific wine, ask that it be ordered from the distributor.

Save 40-50% on Your Heating & Cooling INSULATE NOW!

SAVE ON HEATING & COOLING BILLS

- Stop Hot & Cool Air Leakage
- Exceptional Insulation Qualities Can Reach Any R Value
- Works Hardest When It's Needed The Most - The Colder It Gets The Better It Works - The Warmer It Gets The Better It Works
- Protects Your Home From Ice Damage
- Increases The Value Of Your Home
- Installs Over Existing Insulation

20% Off Stabilized Cellulose Insulation Installed

Call Today For A Free Estimate

Advanced Energy Insulation
248-353-7305

www.insulationusa.com

Three Great Parties! Three Great Options! Choose One that Suits You!

Celebrate New Year's with Our Family

Saturday, December 31 7:30 pm to 2 am

PLATINUM
Burton Manor
 featuring Cassini's Mi rphy band
 Livonia \$160/couple
 734/427-9110

GOLD
Hellenic Cultural Center
 featuring Persiston
 Westland \$125/couple
 734/525-3530

SILVER
Roma Banquets
 featuring Persiston
 Garden City \$75/couple
 734/422-4550

NEW this year: Burton Manor teams up with Oldies 104.3 WOMC and Gail Purtan Ovarian Cancer Research Fund to make your evening even more memorable. Special guest appearance by WOMC's Dana Masucci. A portion of your ticket price goes to Gail Purtan Ovarian Cancer Research Fund.

TICKETS NOW ON SALE!
 Mon through Sat., 10 am to 5 pm

CANTON CINEMA
 www.cantoncinema.com

Ford Rd 1 Mile W of I 275 (734)
ALL DIGITAL STEREO 344-FILM

No Passes Free drink & 25¢ Horn Roll
 ALL STADIUM SEATING SHOWTIMES 12/2-12/8

TITLES AND TIMES SUBJECT TO CHANGE

YOURS, MINE, AND OURS (PG)
 11 15 11 45 1 15 1 45 3 15
 3 45 5 15 5 45 7 15 7 45 9 15
 9 45
 FRI/SAT LS 11 15 11 45

IN THE MIX (PG 13)
 11 00 1 05 3 10 5 15 7 20 9 25
 FRI/SAT LS 11 30

PRIDE AND PREJUDICE (PG)
 11 00 1 40 4 20 7 00 9 40

JUST FRIENDS (PG 13)
 12 35 2 50 5 05 7 20 9 35
 FRI/SAT LS 11 50

CHICKEN LITTLE (G)
 11 00 11 30 1 00 1 30 3 00
 3 30 5 00 5 30 7 00 7 30 9 00
 9 30
 FRI/SAT LS 11 00

COUPON
FREE 20¢ DRINK
 with \$2.50 purchase of 4oz. bag of buttery popcorn
 BEST DEAL in eNewsletter at www.cantoncinema.com

GRAND OPENING NOVEMBER 28, 2005
 50% Off on Selected Jewelry
 Drawing for \$1,000 in Store Shopping Spree

Ebel - Rado - Gucci - Tissot - ESQ - Movado Watch Collection

AGIUSON
 Watches & Fine Jewelry Boutique
 Dearborn
 Watch Sales & Service
 Official Dealer

Entry form must be completed and placed in drawing box no later than December 24, 2005 at 1 00pm. Public drawing at Aguson Watches & Fine Jewelry Boutique will take place December 28, 2005 at 1 00pm. Must be 18 years or older. Employees and family not eligible. No purchase necessary. One entry per person. Need not be present to win.

22174 Michigan Avenue, Dearborn, MI 48124 Phone: 313-561-1259
 Parking in Rear: Located Next to Buddy's Pizza and the Little Cafe, Across the street from Starbucks

BUSCH'S
 Fresh. Food. Ideas.

PRICES EFFECTIVE THROUGH SUNDAY, DECEMBER 4, 2005

SHOP ONLINE AT WWW.BUSCHS.COM

\$1.49 lb. FARM FRESH BONELESS SKINLESS CHICKEN BREAST

\$2.99 POINSETTIA PLANTS IN A 4.5-INCH POT

\$2.99 NAVEL ORANGES 4 LB BAG

\$2.99 SUNBURST TANGERINES 3 LB BAG

2005 Prep Hoop Preview

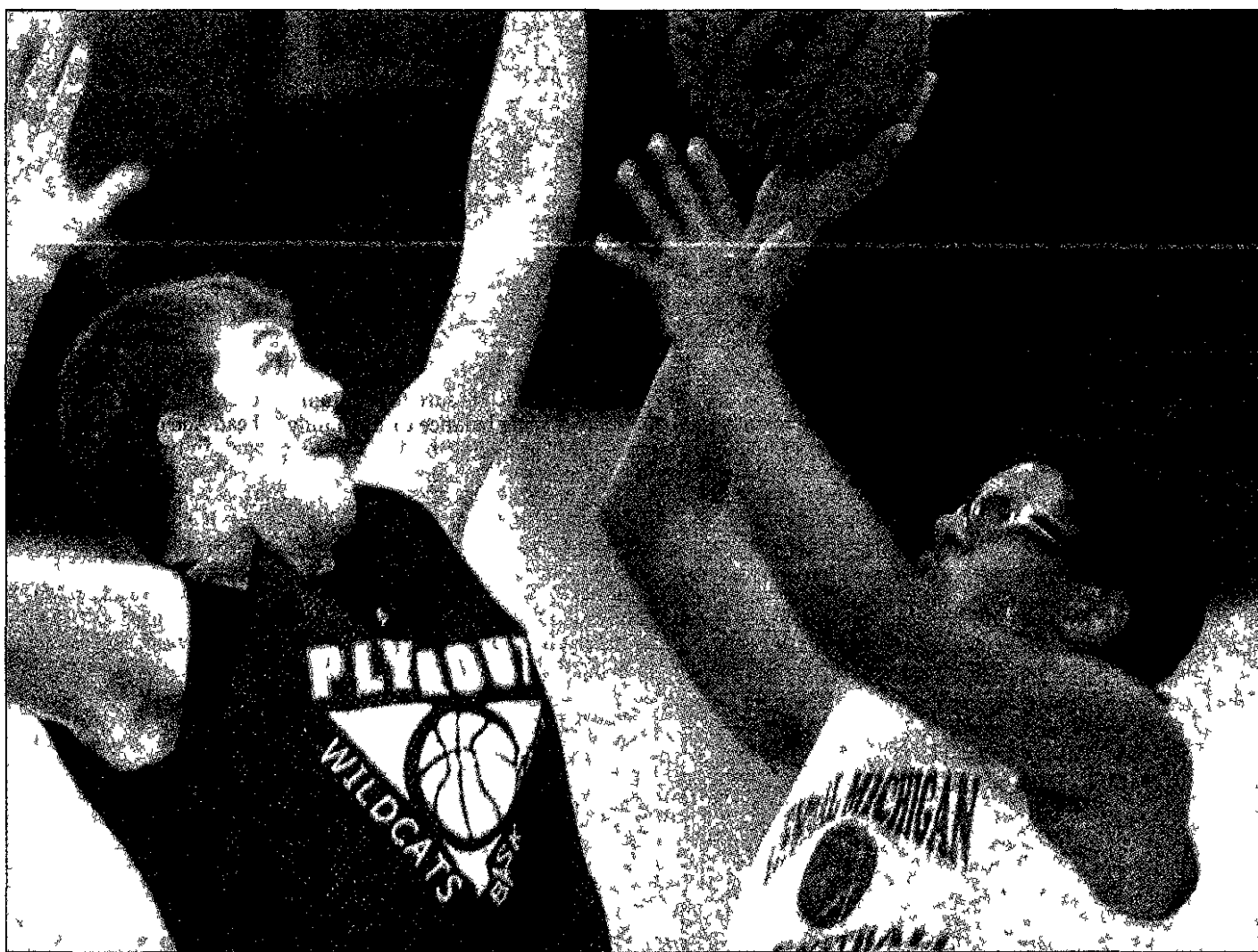

BILL BRESLER | STAFF PHOTOGRAPHER

Plymouth sophomore Jake Hager (left) defends Plymouth Christian Academy's Devyn Govan during the two teams' scrimmage Tuesday afternoon in the Plymouth High School gymnasium. The 6 foot 6 Hager will give the Wildcats a strong presence in the paint this season.

Back in black

No losses to graduation could equate to few losses on court for 'Cats

BY ED WRIGHT
STAFF WRITER

They're *baaacckkkk*.
Plymouth's boys basketball team returns all of its key players from last year's 11-9 unit — and a couple of talented new players as well — which should make the Wildcats a serious contender in this year's Western Lakes Activities Association title chase.

Plymouth finished fourth in the WLAA last season with a 6-5 record. The curtain came down on the Wildcats' inaugural all varsity season when it was derailed by Canton in the first round of the Class A district tournament. "We are looking for an improved season," said coach Tom Van Wagoner. "We have a nice mix of experience, youth and athleticism. The team is setting challenging goals."

Van Wagoner said his team should be well-tested by the time the league schedule commences in January. "Our non-league schedule is a tough one," he asserted. "We open by hosting Dearborn Heights Robichaud, which is one of the favorites to win its league this year. We also visit Mega schools Lincoln Park and Trenton, play against Chelsea

PLEASE SEE WILDCATS, C3

Knee device reduces gridiron injuries

BY ED WRIGHT
STAFF WRITER

The lateral knee stabilizer devices worn by several Salem football players this fall weighed only a pound, but they were worth their weight in gold when it came to preventing knee injuries.

The Rocks did not suffer one medial collateral ligament knee injury this season thanks largely to the device, said Salem athletic trainer Tony Bower. The Rocks had access to 18 of the \$50 braces, which were purchased through funding by the Salem football team booster club and the athletic department. The sta-

bilizers are made out of a combination of steel, neoprene and velcro.

"We had excellent results with the lateral knee stabilizers," Bower said. "Some of our players liked them, some didn't. Our offensive and defensive linemen were the ones that wore them because they're the ones who were more likely to get other players pushed into their legs or opposing players trying to take the legs out."

"Running backs are not good candidates for the stabilizers because they're a little bulky and running backs are usually sensitive to anything that may slow them down even a little."

The device helps the MCL from getting over stressed when a player is hit low from the side, Bower said.

"Normally, when a player's leg is hit with great force from the side, the force can open up the knee and the MCL is injured," Bower said, adding that the MCL injury is one of the most common knee injuries in football.

While Bower said the device was "100 percent effective" for Salem players this past season, there are no guarantees.

"It cannot totally prevent all MCL injuries," he said. "But it can at least reduce the severity of the injuries."

Bower said MCL injuries are graded one through three, with three being the most severe.

"If an athlete suffers a grade-one injury, it usually takes two weeks to get back," Bower said. "A grade three usually means they're done for the season."

The braces are one-size-fits-all and they are adjustable to fit either knee. Bower, a former athletic trainer at both the University of Toledo and Ferris State University, said many professional and collegiate players utilize the device.

For more information on the lateral knee stabilizer device, visit www.McDavid.com or www.medcosupply.com



BILL BRESLER | STAFF PHOTOGRAPHER

Salem athletic trainer Tony Bower displays the lateral knee stabilizer device that was used by several of the school's football players this past season. The device helps prevent serious medial collateral ligament knee injuries.

Football final lived up to all the hype

From my press-box seat just a few feet below the rafters at Ford Field Saturday afternoon, the players in the Division 1 football final between Canton and Rockford looked to be about the size of electric football players.

But that was appropriate considering everything about the game was electric.

The game offered just about everything you would expect when you put two of the state's best teams together on the same field.

■ **Crunching hits** (Rockford's leading tackler could do the most physical game he's ever played in),

■ **Dazzling moves** (there isn't a word in the dictionary that could effectively describe the fake Canton's Deshor McClendon put on a Rockford defensive back during his long

PLEASE SEE HYPE, C8



BILL BRESLER | STAFF PHOTOGRAPHER

Andrea Fleming proved to be a fast learner on the diving board for the Plymouth girls swimming and diving team the past four years.

Plymouth diver adapted quickly to new sport

BY ED WRIGHT
STAFF WRITER

To help prepare for dives this season, Andrea Fleming would visualize the twisting and turning maneuvers she was about to perform before her body sliced smoothly into the water.

Based on Fleming's outstanding senior season, her actual dives went as smoothly as her visualizations.

The Plymouth High School senior enjoyed a banner season for the Wildcats, qualifying for the Division 1 regional meet and placing seventh in the Western Lakes Activities Association's confer-

ence meet with a score of 256.35.

The former gymnast's accomplishments are extra impressive considering she didn't perform her first competitive dive until her freshman year at Plymouth.

"Andrea improved every year of her high school career," said

Plymouth coach Doug Schade. She really came into a tough situation because she hasn't had a steady diving coach here all the time. She would travel out to Eastern

Michigan University for practices during her junior year, which was difficult for her because she was away from the

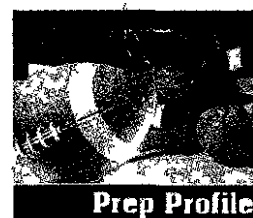

Prep Profile

PLEASE SEE FLEMING, C6

Sidelines

Free baseball clinic

A free strength-and-conditioning clinic for baseball players will be held Saturday, Dec. 3, from noon to 3 p.m. at the Velocity Sports Performance training center, located in the Arctic Edge in Canton. Baseball players will be given the opportunity to learn how to prepare correctly for their 2006 season by attending the special demonstration clinic that will be geared to increase overall athletic ability, including acceleration, speed, balance, quickness, strength and power.

Dennie Taft, the former strength-and-conditioning coach for the Detroit Tigers, will instruct drills and exercises used at Velocity Sports to train professional baseball players. Attendees will also get a chance to meet Detroit Tigers pitcher Nate Robertson and receive an autographed picture of Robertson as part of the clinic.

For more information, contact Velocity Sports Performance at (734) 485-2561.

Free throw aces

Canton Leisure Services and the Plymouth Elks held their annual free throw competition on Saturday, Nov. 19, at the Summit on the Park in Canton. Following are the winners for each age group.

■ **ages 8-9:** 1st place girls - Madison Neff; 1st place boys - Taylor Burke, 2nd place girls - Paige Slominksi, 2nd place boys - David Torrey, 3rd place girls - Katie Stevens; 3rd place boys - Graham Eanes.

■ **10-11:** 1st place girls - Sarah Yursis, 1st place boys - Nicholas Flowers, 2nd place girls - Devin Slominksi, 3rd place boys - Zach Hardy.

■ **12-13:** 1st place girls - Bridget Cole, 1st place boys - Josh Osinski, 2nd place girls - John Polonchan, 3rd place boys - Evans Peters.

Youth lacrosse

The City of Plymouth Recreation Department is offering a youth lacrosse program for boys and girls in grades third through eighth beginning in the spring 2006. The program will be instructional at the beginning and will add competitive scrimmages and games as the players' skills develop.

The season will run from mid-April through mid-June with all practices and games played on mid-week nights only.

Registration will be held the entire month of January. Visit the City of Plymouth's Web site at www.ci.plymouth.mi.us, or call (734) 455-6620, Ext. 304.

Plymouth boosters

The final meeting of the year for the 2005 Plymouth Wildcat Football Boosters will be held Tuesday, Dec. 6, at 7 p.m. in room 401 of Plymouth High School. Nominations for next year's board of directors will be voted upon.

This deer-hunting season is far from over

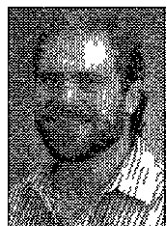

Outdoor Insights

Bill Parker

Firearms deer season is winding down. Wildly fluctuating weather — warm and sunny one day, wind swept and snowy the next — and a smaller deer herd than in past years will likely result in

a lower overall deer kill during the 16-day season, which ends Nov 30. Preliminary numbers have not been released by the state Department of Natural Resources, but indications from reports coming in from hunters around the state point to a lower than normal firearms season harvest. But that's not to say the deer hunting season is almost over. Far from it. Hunters who haven't filled their tags yet still have plenty of opportunities

ahead. For starters, the December archery deer season opens statewide on Dec 1 and runs through Jan 1. Bowhunters can use their archery license, or their regular (not the restricted) combo license, to tag either a buck or a doe. Antlerless licenses are also available in many areas of the state.

On Dec 2, muzzleloader season opens in the Upper Peninsula and the southern Lower. The muzzle season opens Dec 9 in the northern Lower Peninsula.

The muzzleloader season is usually a nine-day hunt, but this year the DNR has expanded the season in southern Michigan to 17 days, running Dec 2-18. The UP season is Dec 2-11 while the season in the NLP runs Dec 9-18.

The reason behind the change in southern Michigan is to get hunters here to har-

vest more antlerless deer.

Over the past several years, the state has been openly trying to reduce Michigan's deer herd, which is estimated by DNR biologists to stand around 1.6 million to 1.7 million animals. Their goal is to reduce the herd to approximately 1.3 million to 1.4 million animals, which they feel is more in tune with the habitat available in Michigan. To reach that goal, biologists are encouraging hunters to kill more does — producers. Harvesting males of a species is not a good approach to population control. The way to manage a population is to reduce its reproductive ability and to do that the producers must be reduced.

Deer numbers have successfully been reduced in the Upper Peninsula and the northern Lower, where some hunters feel they have been reduced too far. Now, biolo-

gists have their sights set on the southern third of the state, where half of the state's deer population resides.

DESIGN A WILD TURKEY PATCH

The Michigan DNR is encouraging students to submit a design for the third annual wild turkey patch contest, which is being sponsored by the Michigan chapter of the National Wildlife Turkey Federation, Project WILD and the Michigan DNR. All entries must be postmarked by Dec 5, 2005.

Students from kindergarten through grade 12 can participate in the contest. The winning design will be incorporated into the 2007 Michigan wild turkey management cooperator patch. The winner will receive an award of \$100.

This is a great opportunity for youth to use their design skills and creativity, and help wild turkeys by improving their habitat in Michigan. Dale Elshoff, Project WILD coordinator at Michigan State University, said in a press

release: "Wild turkeys disappeared from our state in the early 1900s, but now, thanks to proper management, Michigan's turkey population has returned to healthy levels."

Michigan's wild turkey patch program is coordinated by the Michigan chapter of the NWTF, in partnership with the DNR. Young hunters, ages 12-17, who have a valid wild turkey hunting license may receive a free patch. Adult hunters, collectors and other interested individuals may purchase the patch for \$5, including postage and handling.

For more information and complete contest rules, visit www.carrs.msu.edu/projectwild/ or contact Dale Elshoff at elshoff@msu.edu or (517) 355-1712.

(Bill Parker covers the outdoors for the Observer & Eccentric Newspapers. Hunters and anglers are urged to report their success. Questions and comments are also encouraged. Send information to Bill Parker c/o Outdoors 805 E. Maple Birmingham MI 48009.)

DECEMBER 2ND & 3RD

FOR TICKETS CALL **734-453-8400** **ticketmaster**

PLYMOUTH WHALERS VS **MISSISSAUGA ICE DOGS**
DECEMBER 2ND 7:30PM

PLYMOUTH WHALERS VS **KITCHENER RANGERS**
DECEMBER 3RD 7:30PM

FRIDAY DECEMBER 2ND 7:30PM AAA SAFETY NIGHT
SATURDAY DECEMBER 3RD 7:30PM WINDOW DECAL GIVEAWAY

COMPUWARE SPORTS ARENA
 14900 BECK ROAD PLYMOUTH TWP, MI 48170
www.plymouthwhalers.com

NOTICE OF PUBLIC HEARING
CHARTER TOWNSHIP OF PLYMOUTH
REQUEST FROM SOIL AND MATERIALS ENGINEERS, INC., FOR AN INDUSTRIAL FACILITIES EXEMPTION CERTIFICATE
TUESDAY, DECEMBER 13, 2005

PLEASE TAKE NOTE that a public hearing will be held on Tuesday December 13 2005 during a regular meeting of the Board of Trustees of the Charter Township of Plymouth to consider a request from Soil and Materials Engineers Inc for a twelve year Industrial Facilities Exemption Certificate covering an addition to their existing corporate headquarters located at 43980 Plymouth Oaks Blvd Lot 7 and part of Lot 6 Plymouth Oaks Business Park Plymouth Township Wayne County Michigan.

The request is on file in the Clerk's Office where it is available for public perusal during regular business hours 8:00 a.m. to 4:30 p.m. Monday through Friday. Any Township resident or member of any taxing authority within the Township of Plymouth shall have the right to appear and be heard. Written comments directed to the Clerk and received prior to the date of the meeting will be considered. Following the public hearing the Board of Trustees may consider the request.

The public hearing, commencing at 7:00 p.m. will be held in the Meeting Room at Plymouth Township Hall 42350 Ann Arbor Road Plymouth Michigan 48170 on Tuesday December 13 2005 during the regularly scheduled Board of Trustee Meeting. Telephone number 734 354 3224.

Marilyn Messengill Clerk
 Charter Township of Plymouth

Published December 1 2005

NOTICE OF PUBLIC HEARING
CHARTER TOWNSHIP OF PLYMOUTH
REQUEST TO TRANSFER INDUSTRIAL FACILITIES EXEMPTION CERTIFICATE NO. 03-312 FROM VISTEON CORPORATION TO AUTOMOTIVE COMPONENTS HOLDINGS, LLC
TUESDAY, DECEMBER 13, 2005

PLEASE TAKE NOTE that a public hearing will be held on Tuesday December 13 2005 during a regular meeting of the Board of Trustees of the Charter Township of Plymouth to consider a request to transfer Industrial Facilities Exemption Certificate No 03 312 from Visteon Corporation to Automotive Components Holdings LLC for a facility located at 14425 Sheldon Road, Plymouth Township Wayne County Michigan.

The request is on file in the Clerk's Office where it is available for public perusal during regular business hours 8:00 a.m. to 4:30 p.m. Monday through Friday. Any Township resident or member of any taxing authority within the Township of Plymouth shall have the right to appear and be heard. Written comments directed to the Clerk and received prior to the date of the meeting will be considered. Following the public hearing the Board of Trustees may consider the request.

The public hearing, commencing at 7:00 p.m. will be held in the Meeting Room at Plymouth Township Hall 42350 Ann Arbor Road, Plymouth Michigan 48170 on Tuesday December 13 2005, during the regularly scheduled Board of Trustee Meeting. Telephone number 734 354 3224.

Marilyn Messengill Clerk
 Charter Township of Plymouth

Published December 1 2005

ENERGY answers

Dial Down & Save

The cost of natural gas to heat your home will be higher this winter. But lowering your thermostat even one degree can save you money on your home heating bill. And month after month, your savings will continue to add up.

For tips on how to reduce gas consumption and for information on financial assistance for low-income families, visit consumersenergy.com/energyanswers. Or call 800-477-5050. A customer service representative is ready to help.

Request our free brochure, *More Than 100 Ways to Save on Your Energy Bill*. Or view it online.

consumersenergy.com/energyanswers

Consumers Energy
 Count on Us

PDF0503893 3

REDEFINING FIT

... Beautifully

Our new Naturalwear bras incorporate the same beautiful fabrics and styling as the bras you wore before your breast surgery. Designed with your comfort and security in mind, they feature Cool Max pockets and soft, yet supportive fabrics.

Discover the beautiful fit you deserve!

WRIGHT & FILIPPIS

Schedule your fitting today at any of our 30 locations, or one of these in your area:

www.FirstToServe.com

15044 Michigan Avenue Dearborn, MI 48126 (313) 584-0070

27678 Middlebelt Road Farmington Hills, MI 48334 (248) 615-0041

28453 Five Mile Livonia, MI 48154 (734) 421-8400

PDF05038400

WILDCATS

FROM PAGE C1

in a holiday invitational and host Adrian, which has a strong program.

Leading the charge for Plymouth this season will be seniors Brent Jones (5-foot-10), Josh Le Duc (6-4), D J Coleman (6-1), Jim Wilbur (6-1) and Alex Harvey (6-0). Jones is a smooth-dribbling point guard who led the team in assists last season, Le Duc is a force in the paint and on the perimeter, having averaged 10 points, 10 rebounds and three blocks per game during the 2004-05 season, Coleman paced the Wildcats in scoring (15.0) and steals (3.0), Wilbur was a solid contributor at both ends of the court (8.0 points, 4.0 rebounds) while Harvey supplies a top-notch skills along with a high energy level.

Plymouth has a stellar junior class as well. It is led by 6-3 forward Kulraj Sandhu, who averaged seven points and three rebounds a contest as a sophomore.

"Kulraj is a junior with senior experience," Van Wagoner said.

Other key juniors include Austin Barnett, a 6-0 forward who can rebound, defend and run the court, LaBroderick Caldwell, who is "very explosive," according to Van Wagoner, and Nick Boyd, a strong, athletic low-post player, who "brings size and strength to the mix."

A pair of sophomores will also be seeing considerable playing time, Van Wagoner said.

Brandon Roberts, a 5-10 guard, gained valuable experience while starting in the Wildcats' district game last season, while 6-6 Jake Hager gives the Wildcats a strong low-post player who will either provide strong play off the bench or from the starting line-up.

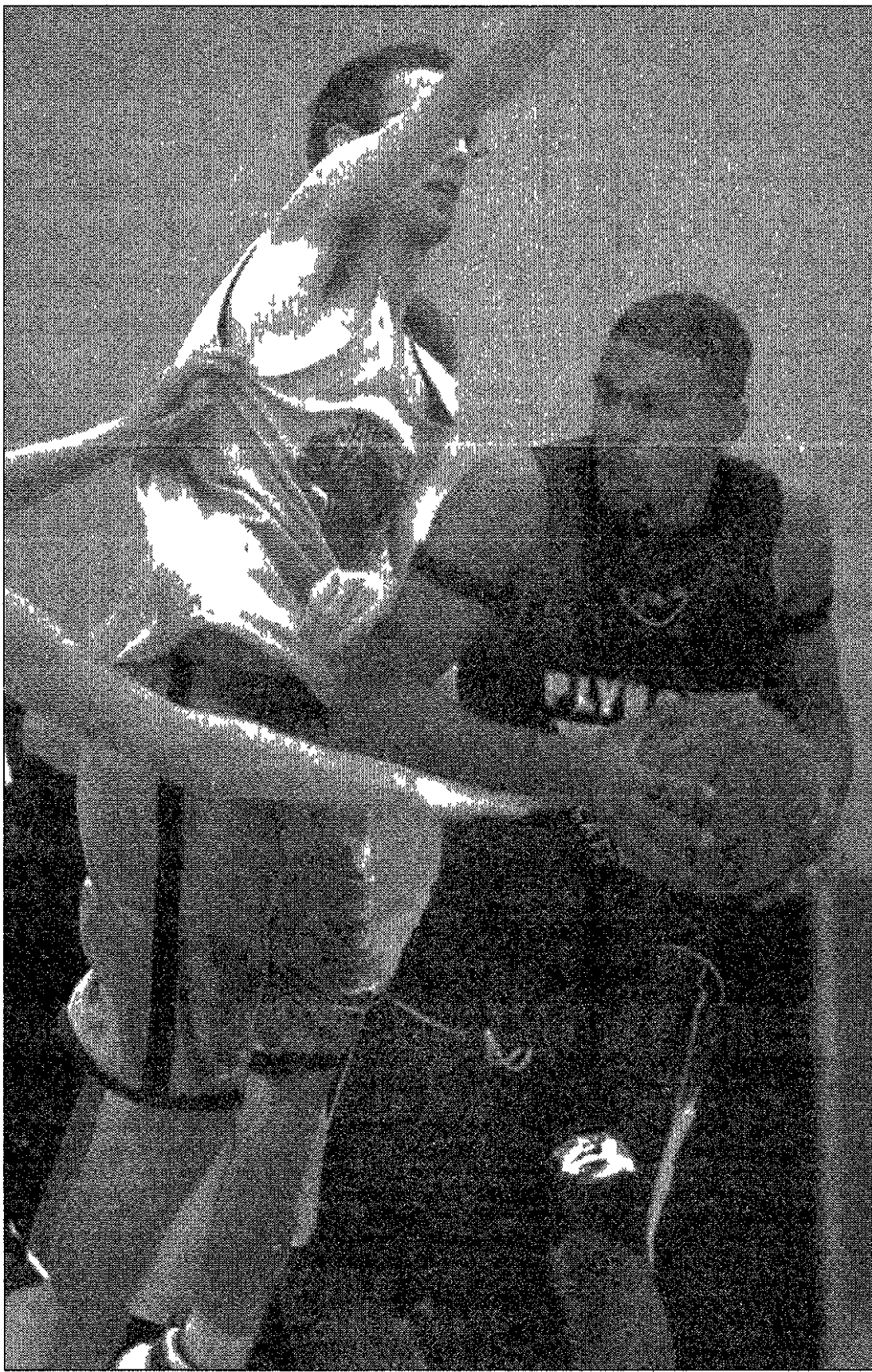

Plymouth Christian Academy's Scott Brandt (left) makes Plymouth's Josh Le Duc work hard for a shot during Tuesday's scrimmage at Plymouth High School.

BILL BRESLER | STAFF PHOTOGRAPHER

Branch and Company returning Wayne Memorial, the other co champ seems to reload with success every year. Livonia Franklin returns

just about everyone, including Andre Bell and will be tough. Northville has size and experience at the top with Alvin Storrs and Chris Lorente, and

our cross-campus rival Canton, has Andre Bridges and a lot of size inside.

ewright@hometownlife.com | (734) 953 2108

Whalers lose shootout

It's fair to say the Plymouth Whalers gave the top rated Peterborough Petes all they could handle in a 6-5 shootout loss in an Ontario Hockey League game played Saturday night before 2,647 at the Compuware Sports Arena.

In winning the shootout, Peterborough — the OHL's top team with a record of 20-2-1-0 — has now won 15 games in a row. In losing the shootout, Plymouth (13-8-1-3) remains in first place in the OHL's West Division and picked up a point on Saginaw, which lost 8-2 to Owen Sound on Saturday.

Despite the 10 goals through 65 minutes of play, there was never more than a one-goal differential. Peterborough's Dan Ryder and Steve Downie scored in the shootout to decide the game. Earlier, Patrick Kaleta scored a pair of goals to pace the Peterborough attack, while Aaron Dawson, Jordan Morrison and Fredrik Naslund scored singles.

Plymouth received single goals from John Vigilante, Vaclav Meidl, Jared Boll, James Neal and Andrew Fourmier. Evan Brophy contributed three assists and Ryan McGinnis two for Plymouth. There were two penalty shots awarded, which was a first since Compuware Arena opened in 1996.

The teams traded seven goals in a wild first period, which ended with Plymouth ahead, 4-

3 Vigilante, Meidl, Boll and Neal scored for the Whalers.

Naslund tied the game at 4-4 on a penalty shot at 5:51 of the second period, but Fourmier gave the Whalers a 5-4 advantage when he scored on a short-handed breakaway with 22 seconds left in the second period.

Kaleta tied the game at 5-5 with 5:17 left in regulation when he scored in the middle of a scramble in front of the Plymouth goal. Whalers goalie Ryan Nie got a piece of the shot, but it trickled over the line to tie the game. That set the stage for the shootout. Plymouth outshot Peterborough, 44-39.

Peterborough's 15-game winning streak is approaching league records. The 1983-84 Kitchener Rangers won 25 straight games from Jan. 11, 1984 through March 16, 1984, the 2004-05 London Knights won 18 straight games from Oct. 23, 2004, through Dec. 8, 2004, the Plymouth Whalers won 17 straight from Feb. 4, 2000 through March 12, 2000, and the 1987-88 Windsor Spitfires won 16 consecutive games from Jan. 18, 1988, through March 3, 1988. Plymouth is idle until Friday when it hosts Mississauga at 7:30 p.m. at the Compuware Sports Arena. The Whalers host Kitchener Saturday at 7:30 p.m. Tickets are available for all Whaler games by calling (734) 453-8400.

CITY OF LIVONIA PUBLIC NOTICE VEHICLE AUCTION

Under Provisions of Sections 2-32-070 and 3-05-1006 of the Livonia Code of Ordinances The Police Department will be conducting an Auction of Forfeited vehicles

Friday December 9 2005
Inspections begin at 9:30 a.m.
Auction begins at 10:00 a.m.

Midwest Auto Auction & Services Inc
14666 Telegraph
Redford MI 48239

ALL VEHICLES TO BE AUCTIONED MAY BE VIEWED BETWEEN 9:30 A.M. AND 10:00 A.M. ON THE MORNING OF THE AUCTION. VEHICLES ARE SOLD 'AS IS' AND ALL SALES ARE FINAL.

ALL SALES MUST BE IN CASH AND ARE DUE IN FULL THE MOMENT THE BID IS ACCEPTED.

VAL VANDERSLOOT City Clerk

Publish December 1 4 & 8 2005

CE053033

BEAT OLD MAN WINTER!

Now Only \$599.00 (List Reg. \$699.00)

- 5.5 HP Tecumseh Engine
- 13 Aggressive X TracTires
- Ergonomically Designed Hand Controls
- Fold Down Handlebar for easier storage
- Durable Aluminum Gear Case
- Long Life Revers Ble Skid Shoes
- Manual Quick Turn Chute Rotation
- Disc-O-Matic Drive System (an Arenas exclusive)
- 120 Volt Electric Start
- 12 Impeller
- Free Set Up

Now Only \$539.00 (List Reg. \$599.00)

- 5HP 2 Cycle Engine
- Patented Dura-Clean™ Auger Limited Lifetime Warranty
- Large F.I. Gas Cap and See Through
- Large Capacity Fuel Tank (1.2 quart)
- Fold Down Handlebar
- Polymer Blower Housing
- 120 Volt Electric Start
- Free Set Up

WESTLAND LAWN & SNOW

Open Monday - Friday 9-6 • Saturday 10-2
27427 Joy Rd. Just West of Inkster • PHONE: 734-261-1250

TOWN 'N' COUNTRY LANES

1100 S. Wayne Rd. • Westland
Between Cherry Hill & Palmer

Join us for our New Years Eve Party!
Call now for reservations

Ask about our BIRTHDAY PARTY PACKAGES

OPEN BOWLING SPECIALS

Mon. & Fri. 11 am - 6 pm \$1.35 a game
Sun. Eve. 6 pm - 9 pm \$1.75 a game

9 PIN NO TAP DOUBLES & SINGLES

Prize \$, Mystery Game, Lucky Strike
Saturdays 10:30 pm

DURING THE MONTH OF DECEMBER - 9 PIN NO TAP
2 Couples for the Price of One

For More Information Call (734) 722-5000

Filter PURE ENTERTAINMENT!

Let us entertain you! Every Thursday

TRAIN WHERE THE PROS TRAIN!

Velocity SPORTS PERFORMANCE

Improve your athletic potential in:
BASEBALL
SOFTBALL
FOOTBALL
SOCCER
LACROSSE
TRACK & FIELD
SWIMMING
TENNIS

NOW OPEN Inside the Arctic Edge Ice Arena

Velocity Sports Performance is where people of ALL AGES AND SKILL LEVELS maximize their athletic potential. With the help of our professional degreed and certified coaches, you will actually experience the thrill of accelerated gains in speed, power and agility—the three pillars of athleticism. And you will do it all in tightly focused groups of six or fewer.

CALL TO SCHEDULE YOUR FREE TRIAL SESSION TODAY!

NOW ENROLLING!
Youth • Adult • Team Training Programs

OUR STATE-OF-THE ART TRAINING CENTER INCLUDES:

- 10,000 sq. ft. indoor training center
- 40 yard Track w/ electronic timing system
- Strength/cardio area
- Power Lift Equipment
- Video analysis

46615 Michigan Ave. • Canton, MI 48188
(734) 485-2561
www.velocitysp.com/canton

No more scapegoats: Now that 'Mo

How did this happen? My mind can't help but to go back to late July in Allen Park. For whatever reason, I always enjoy going out to Lions training camp. I guess it's because my favorite season — fall — is right around the corner. Fall has leaves falling, cider mills, the return of football, start of hockey and hoops, and hope. Yes, hope that this year just might be the year the Lions get it right. One playoff win since 1957, no sniff of the playoffs since 1999, this is the year it will be different.

Allen Park was different this July, as well. You had the sense that it was not talk this time. You had the thought that since this division was so mediocre, the Lions could do just enough to at least slip back into the playoffs and raise the North Division banner. Who knows? Anything can happen in



Sean Balgjian

the playoffs, right?

When you talked to the players after practice, there was no talk of getting better, it was playoff talk. To a man, the motto seemed to be "playoffs or bust." The Lions were in Year 3 of the "Mooch" regime and looked loaded. Joey Harrington finally had some weapons, Kevin Jones was going to

see the ball a ton, Rogers and the Williamses were going to light the league up.

Who could stop this offense? The Lions, of course. What happened? How did this go so wrong, so fast?

I know many would like to believe it was

Mooch's fault, and are glad he is gone today. Does that mean we will see vast improvement in the last five games under Dick Jauron? Does it mean the excuses will go away since the scapegoat has as well?

First off, Steve Marucci deserved to lose his job. He is a good coach and good man, but it was not working here. Perhaps he was too stubborn, perhaps his system is archaic and obsolete — whatever the reason, it was not working.

Joey Harrington has not progressed, the argument could be made that he has regressed. Is it Joey, or is it the system? I think in this regard, it's 50-50. This system is one in which a quarterback is supposed to excel with high-percentage passes, and Joey is having a problem doing even that. It always makes me laugh when I hear people say that he is in the wrong system, he is

Bob Neugebauer
travel
Serving Eastern Michigan For 25 Years
Voted One Of Michigan's Best
FULL SERVICE TRAVEL AGENCY
From Weekend Getaways To Exotic Vacations
•Las Vegas Specialists •Cruise Specialists
•Group Travel Experts
Mon-Fri 9am-5:30pm • Sat 9am-1pm
(586) 77-VEGAS
(586) 778-3427
16170 Thirteen Mile • Roseville 48066
Visit us online at www.77vegas.com

DAMP or WET BASEMENT?
MIDWEST WATERPROOFING
\$750.00 OFF
Full Basement Waterproofing.
Offer available to the first 50 homeowners.
Lifetime Guarantee • 100% Financing
Special Senior Discounts
1-800-718-9889

FOR 2006 - NORTH BROTHERS FORD LEADS THE WAY!

2006 Ranger XLT 4x4 Supercab
4.0 V6 automatic sliding rear window Pioneer 290 W sound pkg ar speed control tilt wheel privacy glass
— WAS... \$26,325 —
24 MO. LEASE \$14372*

2000 Mustang Convertible
Black, only 34,000 miles
ONLY \$9995*

NORTH BROS
33300 FORD RD. WESTLAND
www.northbros.com
www.serviceapps.com

Monday & Thursday... 9-9
Tuesday, Wednesday, Friday... 9-6
Saturday... 9-3
NEW VEHICLES 1-734-524-1264
USED VEHICLES 1-800-649-2127

North Brothers Ford is pleased to announce the addition of **PHIL PRECZEWSKI** to our sales staff. Phil invites all of his previous customers to see him for the best deal!

Fly Saab Holiday Event
WHEN YOU USE TO BUILD JETS, YOU DON'T BUILD JUST ANOTHER CAR

LEASE A 2006 SAAB 9-3 SPORT SEDAN
LEASE A 2005 SAAB 9-5

SAAB OF TROY
1819 MAPLELAWN • MAPLE ROAD AT CROOKS • IN THE TROY MOTOR MALL
visit us online at www.saaboftrroy.com
For an appointment please call **1-866-233-3486**

THIS WEEK'S GAMES!
ADVERTISER PICKS
Sunday, December 4, 2005

Minnesota	at	Detroit
Atlanta	at	Carolina
Buffalo	at	Miami
Cincinnati	at	Pittsburgh
Dallas	at	NY Giants
Green Bay	at	Chicago
Jacksonville	at	Cleveland
Tampa Bay	at	New Orleans
Washington	at	St. Louis
Denver	at	Kansas City
NY Jets	at	New England
Oakland	at	San Diego

Monday, December 5, 2005
Seattle at Philadelphia

Observer & Eccentric NEWSPAPERS
PICK THE PROS!
CONTEST
WIN A \$50.00 Shopping Spree From HOLIDAY MARKET in Royal Oak!!

FIREARM EXCHANGE
BUY • SELL • TRADE
NEW and USED

OUR NEW LOCATION IS NOW OPEN!
Please visit us at
1310 S. Wayne Rd.
Just S. of Cherryhill

We are your local source for the best prices on firearms. We stock all your gun and rifle accessory needs.
734-729-GUNS

Advertisers Pick

Bruce Campbell Brian Campbell Dodge	Bill Albrecht Bruce Campbell Dodge	Joe Gagnon Joe Gagnon Family Heating and Cooling	Wah Wong Firearm Exchange	Larry Daye Grand Rapids Bedding Mattress Superstore	Dr. Haddad Laser Eye Institute	Baby Leo Midwest Waterproofing	Brian Godfrey Pat Milliken Ford	Bob Neugebauer Bob Neugebauer Travel	Brian North North Bros Ford
7-5 84-80	11-1 80-84	10-2 84-80	8-8 84-80	7-5 85-89	4-8 81-83	8-6 82-82	10-2 82-82	7-5 74-76	9-3 86-88
Detroit Carolina Buffalo Cincinnati NY Giants Chicago Jacksonville Tampa Bay St. Louis Denver New England San Diego	Detroit Atlanta Buffalo Cincinnati Dallas Chicago Cleveland Tampa Bay Washington Denver New England San Diego	Minnesota Atlanta Miami Cincinnati NY Giants Chicago Cleveland Tampa Bay Washington Denver New England San Diego	Minnesota Atlanta Miami Pittsburgh Dallas Green Bay Cleveland Tampa Bay St. Louis Kansas City New England Oakland	Minnesota Carolina Miami Pittsburgh NY Giants Chicago Cleveland New Orleans St. Louis Denver New England San Diego	Detroit Carolina Buffalo Pittsburgh NY Giants Chicago Cleveland Tampa Bay St. Louis Denver New England San Diego	Detroit Carolina Buffalo Pittsburgh NY Giants Chicago Jacksonville Tampa Bay Washington Kansas City New England San Diego	Minnesota Carolina Miami Pittsburgh NY Giants Chicago Jacksonville Tampa Bay St. Louis Denver New England San Diego	Minnesota Carolina Miami Cincinnati Dallas Chicago Jacksonville Tampa Bay Washington Denver New England San Diego	Minnesota Atlanta Miami Cincinnati NY Giants Chicago Jacksonville Tampa Bay St. Louis Denver New England San Diego

You'll Always Be Miles Ahead At...
Tennyson CHEVROLET

GM RED TAG EVENT
Now Through January 3, 2006

32570 Plymouth Road • Just East of Farmington Road
Livonia • 734-425-6500
www.tennysonchevy.com

Sales Hours:
Monday & Thursday 8:30 am - 9:00 pm
Tues, Wed, Fri 8:30 am - 6:00 pm

AN AMERICAN REVOLUTION

Family Heating, Cooling & Electrical, Inc.
FAMILY OWNED & OPERATED FOR OVER 30 YEARS
• SALES • SERVICE
• INSTALLATION • PARTS
FURNACES ALL MAKES and MODELS

As seen on YOUR LOCAL EXPERT on WOIV Channel 4 TV

TRANE Carrier YORK
Lennox Coleman
FREE Estimates
Licensed and Insured
Michigan State Lic: 71-01595
734-422-8080
30210 Ford Road • Garden City
Showroom and Parts

PAT MILLIKEN

All New 2006 Fusion
Up to 32 MPG Highway

America's #1 Volume Fusion Dealer!
Pat Milliken
(800) 737-0278
9600 Telegraph Rd
1 Mile South of I 96

'ch' is gone, Millen is accountable

better going downfield. How do you expect his accuracy or completion percentage to improve if he is throwing lower-percentage passes further downfield?

To Joey's credit, the line never gelled. I heard countless times that this line would be a "work in progress" while out in Allen Park. I guess the work has not really started then, based on its play thus far through 11 games.

The receivers — where to begin? Mike Williams was not ready for this level, which I suppose we should have seen coming since he sat out of football a year. Charles Rogers was finally healthy, but decided it was more important to become his own worst enemy and get suspended. Roy Williams continues to show flashes of greatness, but they are few and far between when he is healthy. Marcus Pollard never

provided the impact we thought he would and Ted Tollner could not sack anything as the offensive coordinator. Actually, I think he accomplished part of it — the offense was certainly offensive.

So now we turn our eyes to the interim man, Dick Jauron. The guy who was much maligned for being too conservative with his defensive schemes. Funny how life works out, eh? The guy who probably received more heat than any of the coaches on staff up until this year is now the head coach. Remarkable. Let's be honest folks, if it was not for his defense, it could be very ugly right now. We were supposed to be worried about the defense, but it can be said that maybe it's been the Lions' best unit thus far, with the offense and special teams lacking.

Last, but not least — unless you are

counting his winning percentage since taking over for the Lions in 2001, which is dead last — Matt Millen. The excuses are done, Matt. No more. It's your show now. You have fired three coaches. You have had countless drafts. If things do not progress from here, the buck truly does stop with you.

No more scapegoats, this is *your* team in every sense of the imagination. Do something with it, please. No more talk, we want action. No more building, we want a foundation. Everybody else has been held accountable for your 20-55 record as the Man, when will you?

Are you man enough to step aside yourself if it doesn't work soon?

Listen to Sean Bailgion from 9 a.m. to noon week days on WDFN AM (1130) Sports Radio.

MAN'S BEST FRIEND.
Sports RADIO 1130 WDFN
Detroit's #1 Sports Station
Visit www.WDFN.com to Listen Live

SCORE BIG with Custom LASIK!

The most experienced Custom LASIK Center in Michigan
Now the first with Iris Registration
Results Routinely 20/20 Or Better*

LASER EYE INSTITUTE
The Ball Is In Your Hands...
Make The Call To Schedule Your FREE Consultation With Daniel S. Haddad, M.D.
Offices in Troy and Dearborn
248.689.2020

MEXICAN MONDAYS 25¢ TACOS 4-9 PM
5 CORONAS FOR \$6

2 FOR TUESDAYS BEER DOMESTIC DRAFT & STANDARD MIXED DRINKS 4-11 PM

ALL GAMES NFL, NHL & COLLEGE
\$1 Draughts, \$2 bottles & 25¢ wings

PAPA JOE'S BAR & GRILL

FRIDAYS & SATURDAYS KARAOKE
Open 7 Days a Week!
34275 FORD ROAD WESTLAND
734-722-2884

AVIS FORD

Customer Satisfaction Is Our Number 1 Priority!

2006 F-150 STYLESIDE SUPERCAB 4X4

Trailer Tow Package - Auto, air, loaded.
\$160 OR **\$119**
24 Mo. Tax 24 Mo. Tax
A-Plan w/Z Plan
Bonus Cash

AVIS FORD

CALL **248-355-7519**
29200 Telegraph Road • Southfield
24 Hour Automated Credit Approval 1-800-779-2566
Visit Us 24 Hrs. A Day On The Internet At <http://avisford.com>

IT'S NOT TOO LATE TO PLAY!

To play go to www.oonline.com
Click On The Pick The Pros Icon To Play!
Play week through the Super Bowl! Be entered for a chance to win WEEKLY PRIZES and a GRAND PRIZE TRIP FOR 4 TO LAS VEGAS!

GRAND PRIZE TRIP FOR 4 TO LAS VEGAS!
See details on www.oonline.com

YOUR NAME Could Be Listed Here!

LAST 2 WEEKS WINNERS!
1st Place • Week 11: Greg Malcomb (Plymouth, MI)
2nd Place • Week 11: Lyle Daniels (Westland, MI)
Random Winner • Week 11: Jason Grogowski (Livonia, MI)
1st Place • Week 12: Dana Johnston (Livonia, MI)
2nd Place • Week 12: Susan Feltz (Livonia, MI)
Random Winner • Week 12: David Zalewski (Livonia, MI)

of the Week!

North Bros Ford	Papa Joe's	Saab of Troy	Tennyson Chevrolet	WDFN Radio	WDFN Radio	WDFN Radio	WDFN Radio
9-3 84-80	5-7 78-86	5-7 85-89	9-3 87-87	10-2 98-46	8-4 86-88	6-6 95-49	10-2 94-50
Minnesota Atlanta Cincinnati NY Giants Chicago Jacksonville Tampa Bay Washington Denver New England San Diego	Minnesota Atlanta Cincinnati Dallas Green Bay Jacksonville New Orleans St. Louis Denver New England San Diego	Detroit Carolina Miami Pittsburgh NY Giants Chicago Jacksonville Tampa Bay Washington Denver New England San Diego	Minnesota Carolina Miami Pittsburgh NY Giants Chicago Jacksonville Tampa Bay Washington Denver New England San Diego	Minnesota Carolina Buffalo Pittsburgh NY Giants Chicago Jacksonville Tampa Bay Washington Kansas City New England San Diego	Minnesota Carolina Miami Pittsburgh NY Giants Chicago Cleveland New Orleans Washington Denver New England San Diego	Minnesota Carolina Buffalo Pittsburgh NY Giants Chicago Jacksonville Tampa Bay Washington Denver New England San Diego	Minnesota Carolina Miami Pittsburgh Dallas Chicago Jacksonville Tampa Bay St. Louis Kansas City New England San Diego

EMAGINE

THE MAGIC OF MOVIES & MORE

TWO MOVIE PASSES

2ND PLACE Rochester Mills BEERC O THE ROYAL OAK BREWERY

\$50 GIFT CERTIFICATE
To be used at one of the participating breweries. (Not interchangeable)

GRAND RAPIDS BEDDING CO. MATTRESS SUPERSTORE

NO Down Payments
Interest
Payments of 12 Months

ADJUSTABLE BEDS NOW ON SALE

FREE DELIVERY - REMOVAL - SET-UP - LAYAWAY

TROY/MADISON HEIGHTS
Showroom • 455 E. 14 Mile Rd.
1-866-618 MATS

ROYAL OAK
Showroom Clearance Center
2222 Woodward
1-800-339-MATS

SHELBY TWP-LAKESIDE
Showroom • 45287 Market St.
1-800-518-MATS

MADISON HEIGHTS
Warehouse Clearance Center
52301 Stephenson Hwy.
1-800-668 MATS

WATERFORD
Showroom Clearance Center
4825 Dixie Hwy.
1-800-929-MATS

ROCHESTER HILLS
Showroom • 2067 S. Rochester
1-800-579 MATS

Prime TICKET

Specializing In GREAT Seats For ALL Local And National Events!

Mention This Ad And Receive A **\$20 DISCOUNT** On Your First Purchase!

248-891-6969
Ask For Amy
7421 Orchard Lake Road • West Bloomfield
www.primeseat.com

SPORTS!
CONCERTS!
THEATER!
LOCAL & NATIONAL!

GREAT DEALS AT THE BIG STORE!

NEW 2006 DAKOTA QUAD CAB 4X4
2 Year Prepay Lease \$1,983*

3.7L V6 engine, sliding rear window, air conditioner, CD sound system, rear anti-lock brakes, 22 gal fuel tank, folding rear seat, 18" steel wheels, full size spare & more. Stk #1625009

Chrysler Employee Special Chrysler Emp. Sign-N-Drive Special

27 Month **\$86*** \$999 Total Due 27 Month **\$149*** \$0 Due

NEW 2006 GRAND CARAVAN SXT PACKAGE

Power drivers seat, remote keyless entry, power windows, & locks, tilt wheel, speed century, deep tinted glass, dual sliding side doors, CD sound, custom aluminum wheels and much more!

Chrysler Employee Special Chrysler Emp. Sign-N-Drive Special

27 Month **\$86*** \$999 Total Due 27 Month **\$139*** \$0 Due

BRUCE CAMPBELL DODGE
14875 TELEGRAPH • REDFORD • www.brucecampbelldodge.com 313-538-1500

*Purchase price plus taxes, title, plates. Must add destination, doc. fee, all rebates to dealer. Lease payments based on 12,000 miles per year. Duration lease payment based on 24 months with \$279 total due. Must finance with Chrysler Financial, payments subject to change due to credit approval. Must qualify for lease loyalty, prior sales excluded. Must be an owner or be leasing a Durango or Dakota to qualify for the Ram, Durango, and Dakota lease payment. Limit one per household. Sale ends 12-9-05.

MU spikers put unbeaten record on the line

BY TIM SMITH
STAFF WRITER

Win or lose, the wonderful ride is about to end for the Madonna University women's volleyball team

But Crusaders head coach Jerry Abraham is focusing more on getting his team ready to battle for the National Association of Intercollegiate Athletics championship than on maintaining a perfect record

Of course, a national title will secure an unblemished season for 44-0 MU, ranked No. 3 nationally entering Wednesday's play in the nationals at Point Loma Nazarene University in

San Diego, Calif.

"At this point we don't need too much more motivation," said Abraham last week. "We still have goals to achieve and will work very hard to reach those goals"

"We are fortunate to be one of the participating teams in the NIAA National Championships and we'll prepare to compete for our biggest goal, a national championship"

The Crusaders opened up play at the nationals on Wednesday, taking on Indiana University-Southeast in a Pool C match that took place after this issue of the Observer went to press

By Friday, MU will also face

pool opponents National American (No. 6, 33-1), Azusa Pacific (No. 7, 24-9) and Savannah Art and Design (No. 15, 24-9)

If the Crusaders are one of their pool's two top teams, they will advance to the quarterfinals on Friday

SPECIAL CORE

According to Abraham, the outstanding run - which included championships in the Wolverine-Hoosier Athletic Conference regular season and postseason tournament - is due to a myriad of factors

The top reason is "the core" of the squad, very talented seniors Natalja Timna (Redford resident), Laura Lesko, Ashley Frost and Stefanie Denardin

"These four seniors are the core of our team," Abraham emphasized. "Best of all, they are surrounded by a very talented group of players"

Those include Livonia Churchill alums Jacqui Gatt, a sophomore, and Kelsey Mack, a

freshman

Others include Heather Spooner, Caryn Inman, Becci Crane, Amy Szymanski (Redford/Livonia Ladywood) and freshman Lubovj Tihomirova, like Timna an import from Latvia

Abraham said the team's deep roster gives him the luxury of having different players "stepping up and contributing each night. We have excellent balance across the net and play a fast tempo"

Another primary reason for the Crusaders' excellent season is the fact the team is comprised of athletes "with a genuine desire to be the best they can be"

"We've had many remarkable seasons at Madonna with each one being special in its own way," Abraham continued. "But going through an entire (regular) season undefeated is really something. They work extremely hard, love playing with each other and are really focused"

FLEMING

FROM PAGE C1

rest of the team

"But she was dedicated to getting better and she improved dramatically, especially this year. Andrea is our school record holder and she's set a standard for future divers here to try to meet or surpass"

NO EXPERIENCE REQUIRED

Fleming had zero competitive diving experience when she walked into her first Plymouth swimming and diving team practice in August of 2002. But she was equipped with two vital elements - athleticism and determination - that helped overcome the inexperience

"During my freshman year, I pretty much had to learn the basics and the mechanics of diving," Fleming remembered. "The hardest part for me wasn't the physical part of diving - it was the mental part. I'd visualize myself performing the dive, then I'd go do it. When I first started, I thought, 'This isn't so hard.' But now in hindsight, I know now that's not the case. My background in gymnastics helped me a lot at the beginning"

During her junior season, while her teammates practiced in the Salem High School pool, Fleming commuted to Eastern Michigan University, where she was instructed by highly-respected diving coach Buck Smith

"We didn't have a diving coach at Plymouth, so they

hired a coach at Eastern to work with us," Fleming said. "We'd go out there four nights a week to practice. The coaching was phenomenal and the equipment we got to use was amazing. The bad part was I was separated from the rest of the team and I'd only get to see them at meets"

Matt Breen was hired to work with the Plymouth divers prior to this season

"Andrea worked hard this year," Breen said. "She also did a good job working with the younger divers. She definitely left her mark on the program and did a nice job of passing the torch to the younger divers"

A B-plus student, Fleming's favorite class at Plymouth is "Early Childhood Education"

"We get to work at the 'Kidde Campus', which is like a preschool located at the high school," Fleming said. "It's a great class for me because I want to go into education at the elementary level, so it's good experience. We work with the preschoolers, draw up lesson plans, a little bit of everything"

For the past six years, she's played the fife for the renowned Plymouth Fife & Drum Corps, which has led to several educational summer trips

"Our big thing every year is to travel to the eastern United States and perform at the historical sites," she said. "We've played at Independence Hall in Philadelphia and the Tomb of the Unknown Soldier. I've really enjoyed it"

ewright@hometownlife.com | (734) 953 2108

NOTICE OF PUBLIC HEARING CHARTER TOWNSHIP OF PLYMOUTH PLANNING COMMISSION

PROPOSED ACTION: Request Approval of a Special Land Use

DATE OF HEARING: Wednesday December 14 2005

TIME OF HEARING: 7:00 PM

PLACE OF HEARING: Plymouth Township Hall 42350 Ann Arbor Road

NOTICE IS HEREBY GIVEN that the Planning Commission of Plymouth Charter Township has received an application requesting Special Land Use Approval for expansion of a gas station, relocation of the convenience store and car wash, and construction of a new oil change facility in a General Commercial District (C 2), on Tax ID R-78 010 99 0016 000 and R 78 010 99 0017 701, pursuant to Zoning Ordinance No. 99, Section 13 2 11 and 13 2 12

Application 1901. Applicant, Ecourse Landing, L.L.C.

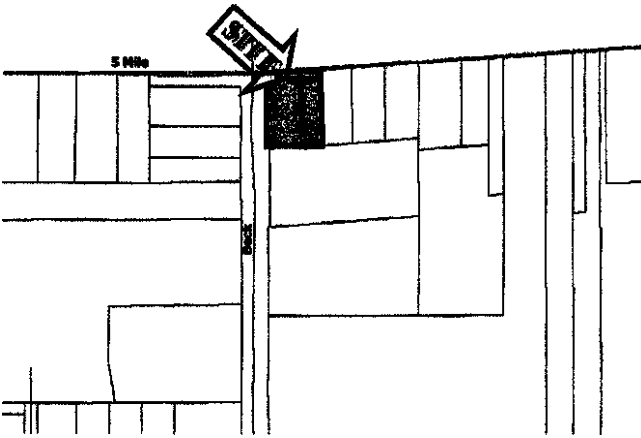

LEGAL DESCRIPTION: For parcel descriptions, see tax records based on Tax ID Nos R-78-010-99-0016-000 and R-78-010-99-0017-701

The application may be examined at the Plymouth Township Division of Public Services Building Community Development Department during regular business hours from 7:30 AM to 4:00 PM. Written comments will be received prior to the meeting and may be mailed to 46555 Port Street, Plymouth, MI 48170 or call 734 453 8131, ext 37. The meeting will be held in the Meeting Room at Township Hall which is located at 42350 Ann Arbor Road Plymouth Township MI 48170

PLEASE TAKE NOTE: The Charter Township of Plymouth will provide necessary reasonable auxiliary aids and services, such as signers for the hearing impaired and audio tapes of printed materials being considered at all Township meetings to individuals with disabilities at the meetings/hearings upon one week notice to the Charter Township of Plymouth by writing or calling the Supervisor's Office, 42350 Ann Arbor Road, Plymouth, MI 48170. Phone 734-453-3840. TDD users: 800-849-3777 (Michigan Relay Service).

KENDRA BARBERENA, SECRETARY
PLANNING COMMISSION

Publish December 1 2005

0608394237

PLANNING COMMISSION CHARTER TOWNSHIP OF CANTON NOTICE OF PUBLIC HEARING

PROPOSED AMENDMENT TO THE ZONING ORDINANCE OF THE CHARTER TOWNSHIP OF CANTON, WAYNE COUNTY, MICHIGAN

NOTICE IS HEREBY GIVEN pursuant to Act 184 of the Public Acts of 1943 of the State of Michigan, as amended, and pursuant to the Zoning Ordinance of the Charter Township of Canton that the Planning Commission of the Charter Township of Canton will hold a Public Hearing on Monday December 5, 2005 in the First Floor Meeting Room of the Canton Township Administration Building, 1150 S. Canton Center Road at 7:00 p.m. on the following proposed amendment to the Zoning Ordinance

BORDINE REZONING CONSIDER REQUEST TO REZONE PARCEL NOS 066 99 00007 000, 066 99 00008 000, 066 99 00111 000 AND 066 99 00112 000 FROM RA, RURAL AGRICULTURAL AND RR RURAL RESIDENTIAL TO R 2, SINGLE FAMILY RESIDENTIAL. Property is located south of Ford and west of Ridge Road

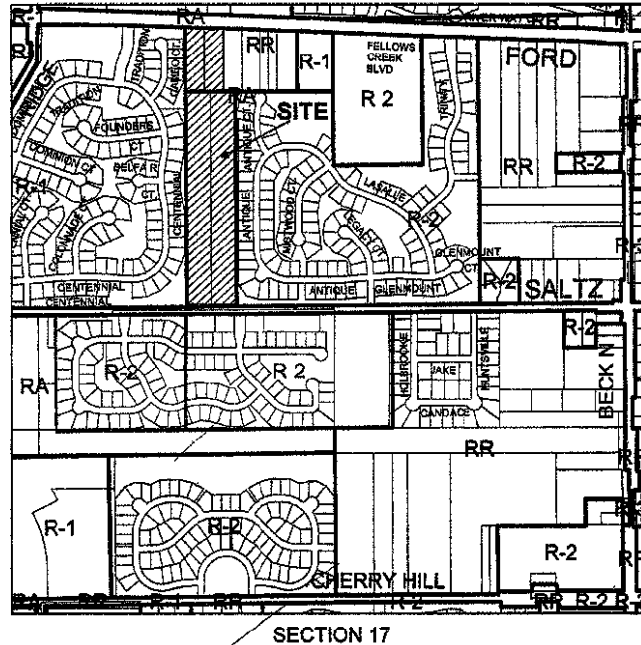

Written comments addressed to the Planning Commission should be received at the Canton Township Administration Building, 1150 Canton Center S prior to Thursday December 1, 2005 in order to be included in the materials submitted for review

Vic Gustafson Chairman

Publish November 13 and December 1 2005

060839028

CHARTER TOWNSHIP OF CANTON ZONING BOARD OF APPEALS AGENDA DECEMBER 8, 2005

Notice is hereby given that there will be a meeting of the Zoning Board of Appeals THURSDAY, DECEMBER 8, 2005 AT 7:30 PM. The meeting will be held in the Board Room at the Township Administration Building located at 1150 S CANTON CENTER ROAD, CANTON MI 48188. The following Agenda will be discussed

Pledge of Allegiance to the flag

Roll Call Randy Blaylock, Jim Cisek, Cathy Johnson, Vicki Welty and Steven Johnson

Acceptance of Agenda

1. Tim Hader of Schonsheck Inc 51331 W Pontiac Trail Wixom, MI 48393 representing US Storage Depot 1400 E Michigan Avenue, Saline MI 48176 for commercial property located at 41984 Ford Road north side of Ford Road between Haggerty and Lilley Roads, appealing Sign Ordinance, Chapter 102 Article II, Section 102 35 (1), a, wall sign variance Zone C 3 Parcel 044 99 0009 701 (Building)

Election of officers for 2006

Approval of the October 13, 2005 Minutes

Approval of the November 3 2005 Minutes

Approval of the November 10, 2005 Minutes

Publish December 1 2005

0608393317



REGISTRATION

is still open!
(No keg, but barrels of expertise and a chance to win \$1,000)

DFCU Canton is celebrating our first year in the neighborhood with a special Orientation event! Let us introduce ourselves and show you how we can help you achieve "Higher Learning, Higher Earning." And while you're here, register to win one of three Grand Prizes of \$1,000!

Take advantage of a special-rate 6-month Certificate with a rate of **4.05% Annual Percentage Yield**** (APY)

4.05%
APY

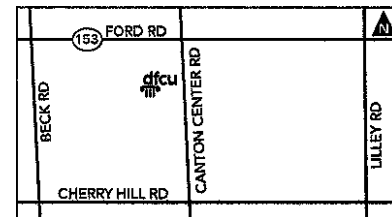

See U there!

1477 N. Canton Center Road
9:30 a.m. - 6 p.m. M-F
9:30 a.m. - 2 p.m. Sat
Call 888 336 2700
www.dfcufinancial.com

*Limited time. Drawings to be held on November 5, November 25 and December 9, 2005. Entries only available at the Canton branch. No purchase required. Entries accepted up to the end of the business day. One entry per individual. Each entry good for all three drawings. **Minimum deposit required to receive quoted APY is \$25,000. Penalties apply for early withdrawal. All rates subject to change without notice.

NCUA: You sav ngs are federally insured up to \$100,000 by the National Credit Union Administration, a U.S. government agency.



PF0606393804

TAX PROBLEMS?
We settle any tax, any year
(248) 985-HELP (4357)

CANTON CINEMA
www.cantoncinema.com
Ford Rd 1 Mile W of I 275 (734)
ALL DIGITAL STEREO 844-FILM
No Passes Free drink & 25¢ corn refills
ALL STADIUM SEATING SHOWTIMES 12:12/8

TITLES AND TIMES SUBJECT TO CHANGE

YOURS, MINE, AND OURS (PG)
11 15 11 45 1 15 1 45 3 15
3 45 5 15 5 45 7 15 7 45 9 15
9 45
FRI/SAT LS 11 15 11 45

IN THE MIX (PG 13)
11 00 1 05 3 10 5 15 7 20 9 25
FRI/SAT LS 11 30

PRIDE AND PREJUDICE (PG)
11 00 1 40 4 20 7 00 9 40

JUST FRIENDS (PG 13)
12 35 2 50 5 05 7 20 9 35
FRI/SAT LS 11 50

CHICKEN LITTLE (G)
11 00 11 30 1 00 1 30 3 00
3 30 5 00 5 30 7 00 7 30 9 00
9 30
FRI/SAT LS 11 00

COUPON
FREE 20oz DRINK
with \$2.50 purchase
o 48oz bag of butter popcorn
the best deal in cinema at
www.cantoncinema.com

A Gift To Leave A Lasting Impression...

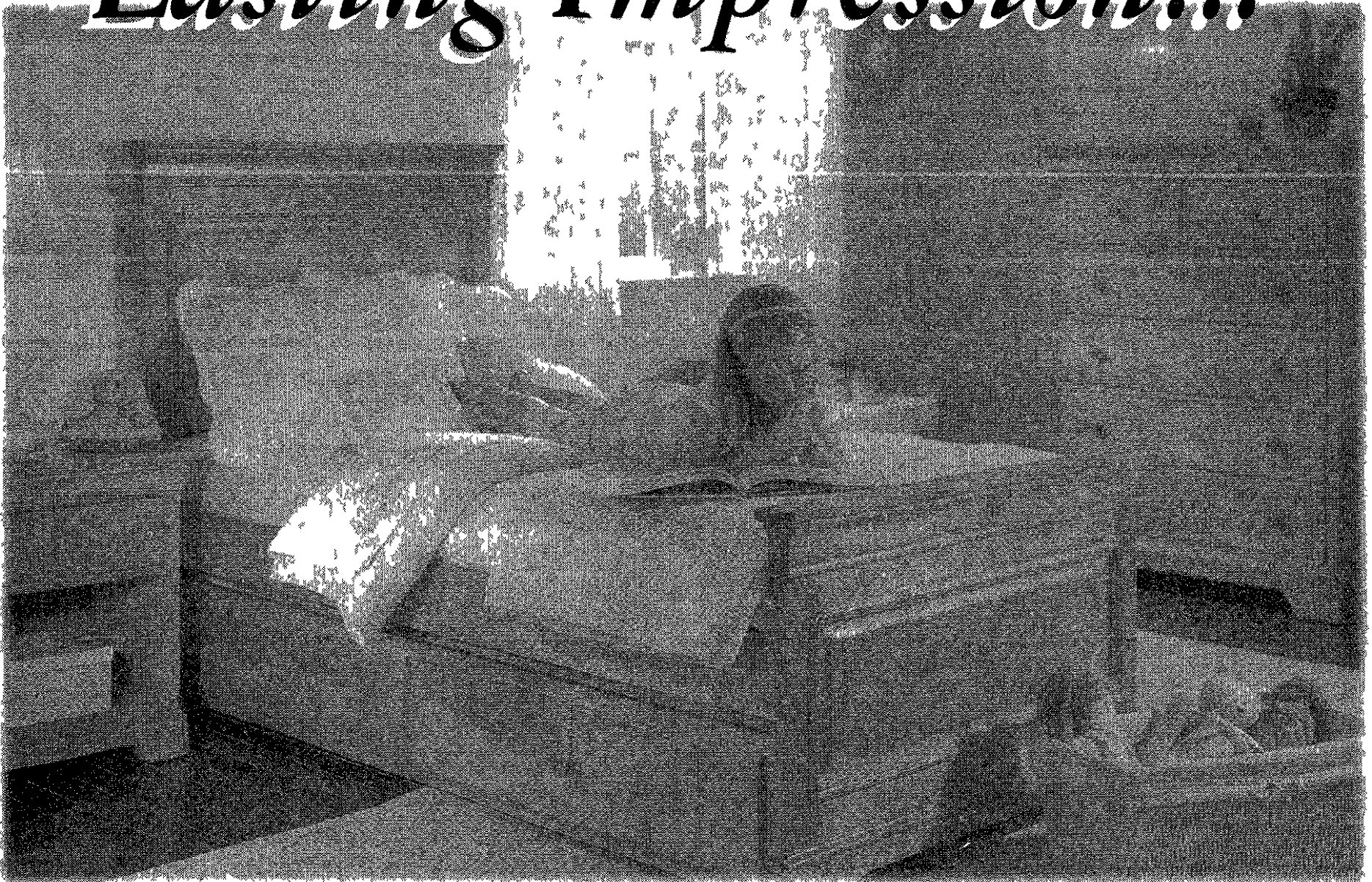

...Youth furniture, the foundation of a child's room, will leave a lasting impression. Right now, in our new display, discover exciting collections! These groupings are designed to grow with your child from crib to college and beyond. Durable, safe, fun and stylish describe the beds, desks, and other storage and organizing options.

Save Big during our Annual Stanley Furniture Youth Sale!

STOREWIDE
HOLIDAY BONUS OFFER...

Save an Additional 10%...on any Stanley Youth Item
AND anything else in our Showroom!

Get your home ready for the holidays, plus find great gift items. Accents, recliners, lamps, artwork, dining sets, desks, sofas, accessories and more unique gift ideas are here!

MARINE CORPS RESERVE



This holiday, leave a lasting impression on a child by bringing in a new, unwrapped toy to benefit the U.S. Marine Corps Reserves Toys for Tots program. While you're here, enter our drawing for a \$500 Walker/Buzenberg Gift Certificate!

Since 1933



Walker/Buzenberg
fine furniture

240 North Main Street • PLYMOUTH • 734-459-1300
Mon., Thurs., Fri. 10-9 • Tues., Wed., Sat. 10-6 • Sun. 1-5
Financing and Gift Certificates available.

Stanley Youth Sale ends 12-18-05. www.walkerbuzenberg.com

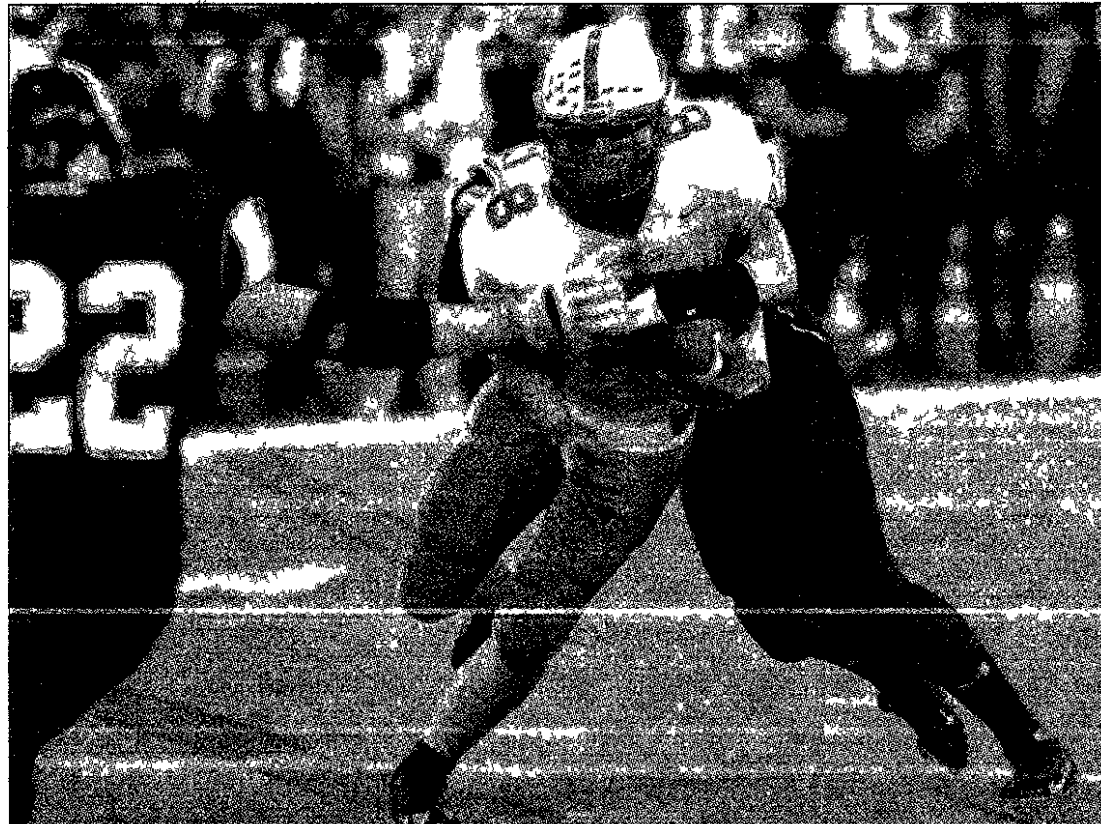

Brandon Fender (8) is one of several Canton starters who will be returning for the 2006 football season. Fender caught a pair of passes in the Chiefs' 31-21 loss to Rockford in Saturday's Division 1 final game at Ford Field.

PHOTOS BY BILL BRESLER | STAFF PHOTOGRAPHER



Canton running back Deshon McClendon will have an opportunity to pad his team records next year when he returns for his senior season. McClendon eclipsed the 2000-yard mark in total yards this season.

Family Heating, Cooling & Electrical
 FAMILY OWNED & OPERATED FOR OVER 30 YEARS
SALES • SERVICE • INSTALLATION • PARTS
 As seen on "YOUR LOCAL EXPERT" on WDIV Channel 4 TV
FURNACE ALL MAKES REPAIR MODELS
 Endorsed by **JOE GAGNON** "The Appliance Doctor" 1270 & 860 AM Radio "Ask The Hardymen" Consumer Advocate Radio Talk Show Host "Front Investigator"
Furnace Cleaning and Inspection
 Reg \$79.95 NOW \$59.95 **SAVE \$20.00**
 With this coupon. Not valid with other offers. Expires 1-31-06
 FREE Estimates Licensed and Insured Michigan State Lic. 71-41569
734-422-8080
 30210 Ford Road • Garden City Showroom and Parts
 65 Trucks for Fast Service!

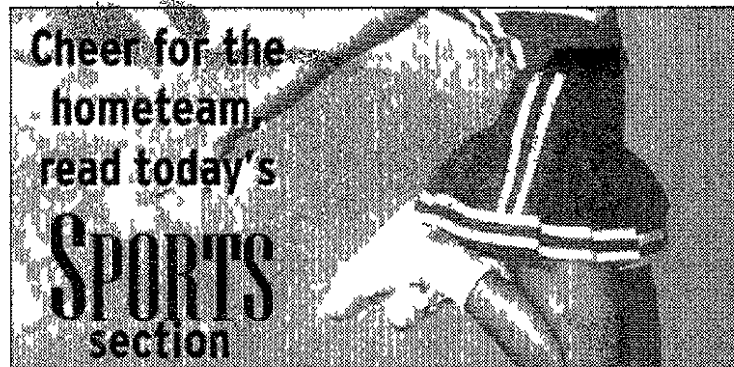

Cheer for the hometeam, read today's **SPORTS** section

HYPE

FROM PAGE C1

reception late in the first quarter.

■ Nearly flawless execution (there was not one turnover committed by either team despite the intense pressure of playing at Ford Field), and

■ Drama (only three points separated the two teams with just over three minutes remaining)

When Canton grabbed a brief 14-7 second quarter lead, it appeared as if the Division 1 championship trophy would be heading straight to the Phase III trophy case. At the time, the Chiefs were mounting long, sustained drives and they seemed to be wearing down the Rams' talented defense.

More importantly, the Canton defense was coming up big when it had to stop Rockford on a couple of key third-down plays.

But in the end, Rockford turned to the big plays it's relied on the past two seasons.

to earn its second consecutive state championship.

The Rams' defense was the quickest bunch I've seen this year. The Chiefs executed several plays that gained anywhere from eight to 12 yards during the regular season and in the playoffs, it was these plays that would often go the distance for Canton. However, the speedy Rams' secondary and linebacking corps prevent-

ed good plays from becoming huge, put-six-points-on-the-scoreboard plays with their excellent sideline-to-sideline pursuit.

Canton's crowd was more than impressive, too. From my seventh-level seat at Ford Field, the huge gathering behind the Chiefs' bench resembled a massive sea of red.

Overall, it was inspiring to see how a group of hard work-

ing athletes pulled an entire community together for one unforgettable afternoon.

CANTON POLICE DEPARTMENT
 1150 S. CANTON CENTER RD.
 CANTON, MI 48188

The following vehicles have been deemed abandoned and will be sold at public auction December 06, 2005 at 10:00 AM. The auction will be held at Westland Car Care Towing, 6375 Hix Rd, Westland, MI 48185. The vehicles will be sold as is, starting bid is for towing and storage.

YEAR & MAKE	MODEL	BODY	VIN#
1998 FORD	F 150	P/U	2FTZX18WXWCA14216
1991 OLDS		4 DR	2G3AL54N4M2346667
1980 BUICK	RIVERIA	2 DR	4Z57RAE429476
1992 CHRYSLER	VAN	VAN	1C4GH54R9NX193776
1991 CHEVY	CAVALIER	2 DR	1G1FP23E6ML160339
1986 DODGE	RAM	VAN	2B6HB23T0GK543456
1993 FORD	AEROSTAR	VAN	1FMCA11U3PZB999967
2004 FORD	F 150	P/U	1FTPX14584NB98356
1995 CHEVY	VAN	VAN	1GBEG25K5SF196464
1989 TOYOTA	CAMRY	4 DR	JT2SV21WXX0294091
1996 PONTIAC	GRAND PRIX	4 DR	1G2NE52T2TC703957
1993 TOYOTA	COROLLA	4 DR	JT2SK12E7P0129843
1990 GEO	PRISM	4 DR	1Y1SK5464LZ104291
1995 DODGE	INTREPID	4 DR	1B3HD46T0SF530163
1990 HONDA	ACCORD	4 DR	1HGCB7657LA143143
1993 FORD	ESCORT	S/W	1FAPP15J8PW210781

Publ sh December 1 & 4 2005

CE6388200



HARDEN • KOHLER • DELTA • HANSGRÖHE

MATHISON HARDWARE

CANTON STORE LOCATION

CLOSING!

Inventory Liquidation SALE 30-50%

Everything Must Go!

Hardware • Kitchen & Bath • Tools
Plumbing • Electrical

6130 Canton Center Road
(734) 455-9440

MAAX • JASON • BLANCO • BERTCH | **ST. THOMAS • GERBER • STERLING • GATCO**
MANHATTAN • US MARBLE • NEW PORT BRASS

Comcast High-Speed Internet.
 It's faster than, well... pretty much everything.

Comcast High-Speed Internet. Leave dial-up and DSL in the dust. With Comcast High-Speed Internet, you can surf the web with a faster, more reliable connection. You'll find Michigan's premier broadband service packs all the power you need to download news, videos and music at lightning fast speeds. Plus, you get enhanced features only available here—like our interactive entertainment portal, Video Mail, PhotoShow, live streaming NHL™ hockey games with Hockey Live, security tools and so much more.

Act fast. Only **\$19.99** a month for 6 months.

Call **1-888-COMCAST**
 www.comcast.com



Speed comparisons for downloads only and compare Comcast download speed of 6.0Mbps (maximum download speed of 384Kbps) to 768Kbps DSL and 56K dial-up. Many factors affect speeds. Actual speeds may vary and are not guaranteed. Limited time offer and is limited to Comcast Cable Video customers who do not currently subscribe or who have not during the past 60 days subscribed to Comcast High-Speed Internet service, located in wired and serviceable areas only. Equipment (including a cable modem) required and offer does not include equipment charges. Following the promotional period, Comcast regular service and equipment charges apply. Service charges for non-Comcast cable video customers vary. Installation for professional installation (for an additional fee) required for non-Comcast cable video customers and rates vary. Prices shown do not include installation, taxes and fees. Pricing and content may change. Not all applications and features are compatible with Macintosh systems. Video Mail requires additional equipment. Hockey Live subject to change. Blackout restrictions apply. NHL™ is a registered trademark of the National Hockey League. See website for restrictions, minimum requirements, and details about service and prices. Use subject to Comcast's terms and conditions. Other restrictions apply. ©2005 Comcast Cable Communications, LLC. All rights reserved.

Home Equity Loan

5.99%
 APR

15-year term
 No points
 No closing costs

Charter One
 Not your typical bank®

No, the rate is not a typo.

To find out more, visit your nearest branch, go to charterone.com or call 1-877-TOP-RATE.

5.99% APR available for qualifying properties in IL, IN, MI and OH with a loan to value (LTV) of 85% or less for loans of \$100,000 to \$249,999 or an LTV of 80% or less for loans of \$250,000 or more. This auto deduct on from Credit Checking and a 15-year term. An equity loan of \$100,000 with a 15-year term at 5.99% APR results in 180 monthly payments of \$843.31. Other rates and terms available. Rates and terms vary by property type, loan amount and LTV ratio. Offer subject to change without notice. 1. To 4 family owner occupied property only. Property insurance required. Flood insurance may be required. Trust review fees ranging from \$85 to \$175 apply for properties held in trust. Not available for homes currently for sale or intended to be sold within six months of closing. All accounts and services are subject to dual approval. See a banker for details. Equal Housing Lender.



Homes do sell during hectic holiday season

BY JULIE BROWN
STAFF WRITER

Selling a home during the winter holidays isn't an impossibility.

"The holiday season always presents some difficulties for both the buyer and the seller," said Jason Miller, broker/owner of RE/MAX Home Sale Services in Plymouth. There are typically fewer home showings, but buyers are more focused.

"You get more of the serious buyer who maybe needs to buy a home," he said. Although corporate transfers are down in this economy, those who do plan such a move often come during the holidays when schools are out to check out a community and housing options.

"The house shows typically very well," Miller said, noting holiday time homes are generally clean and nicely decorated. We tell them to decorate just like they normally would.

Exteriors should be clean and small details matter when selling a home, he said.

Realtors who plan a prosperous 2006 stay focused during the holidays, he added, evaluating properties on the market and really spend some time looking at their marketing plan.

Miller's found the local spring market tends to break earlier here than in other areas of the country, and says it could be pent up demand. During the holidays, there's less competition for sellers, he said, and a home that's marketed properly and priced right can be sold.

Sellers don't have to wait until spring to put a home up for sale, he said. "Waiting isn't always the best thing to do."

Joan Downing, broker/owner of RE/MAX in the Hills Bloomfield Hills, also finds the holiday slowdown isn't insurmountable. There may be less showings, but the quality of the buyer is 10 times better," she said.

Downing said it's important to make your home look festive in a tasteful way. For some homes, just walking into the foyer allows a visitor to bask in the warmth and good feelings.

"That in itself helps sell the home," she said, adding such touches as a fire in the fireplace, candles and a nice wreath on the door all help, as does exterior curb appeal.

Downing doesn't slow down too much when the holidays arrive.

I think it's a time everybody in our profession does use to regroup," she said of the season. Realtors focus on how to improve business and customer service and ask what changes to

make in their business plans.

It's also a great time of year to touch base with clients from the past year. Downing said, "mostly just to say Happy Holidays, I'm thinking about you."

Dr. Kim Shunkwiler and wife Peggy of Wayne moved in February 2002 to their current home. Shunkwiler, a Westland chiropractor, didn't find selling their Dearborn Heights home and moving to the new one during the holidays all that stressful.

Of course, I should talk because Peggy did all the work," he said with a smile, adding it was a little more hectic than usual. The Shunkwilers faced no real hardships and didn't have to come down on their price. "The market was pretty good back then," he said. "Now it's hard to get buyers into your place."

Adam and Karen Olwean were busy in recent weeks preparing for their Thanksgiving move from Westland, where they have lived 11 years in their home, to Livonia. They have two children, ages 7 and 10 and needed more space.

A little bit," he said of the hectic pace of moving now. "But we'll get it done," said Olwean, a route driver for Snyder's of Hanover.

His family is looking forward to having Christmas in their Livonia home. "It's going to be nice," he said.

FEATURED HOMES OF THE WEEK



FABULOUS BLOOMFIELD HILLS

756 Palms Road

Newer construction in exclusive development in Bloomfield Hills. Open floor plan with high end amenities. Gourmet kitchen, every bedroom is a suite. Hilltop setting with extensive professional landscaping. Finished lower level with full kitchen, family room, exercise room and full bath.

\$1,699,000

RONNI KEATING
Top Producer

Office 248.644.7000 Ext. 192

Ronni's Cell 248.330.9750

www.ronnikeating.com



SKBK

SNYDER KINNEY BENNETT KEATING
REALTORS® SINCE 1932

1/2 OFF MAKES THE DECISION
Easy



Cheshire Park CONDOMINIUMS



From the \$170s
Located in Clarkston



Townhome condominiums
Two bedrooms with den or optional third bedroom
Great room with balcony
Attached garage with opener
Complete GE appliance package
Close to historic downtown Clarkston shopping and entertainment

248-922-9626



Models Open Daily 12-6pm
Brokers Welcome
To visit: I-75 exit to Sashabaw Rd,
1/4 mile south of Walden.

1/2% Off - A Whole Lot of Savings!
*Offer good on qualified rate mortgages. See program details. Excludes many homes.

IT IS THE PASSION, PERFORMANCE AND PROFESSIONALISM OF OUR FAMILY OF EMPLOYEES THAT MAKE THE DIFFERENCE AND MAKE ABBEY HOMES THE EASY NEW HOME CHOICE.

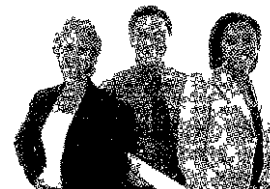

ABBNEY HOMES

Where the Living is Easy

For more information visit MyAbbeyHome.com

Grand Opening!

PHASE III



River Bend Condominiums

Units 3-6 Featuring
Finished Walk-Out Basements
Included in the Sale Price -
Starting at **\$289,900**
Total 2300 sq. ft. Living Area

OPEN HOUSE:
December 2,3,4, 2005
12:00 Noon to 5:00 pm

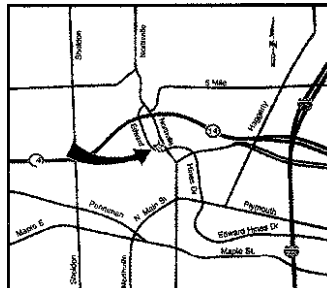

Northville Rd at
Edward Hines
Plymouth, MI

























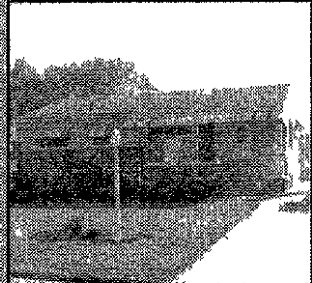

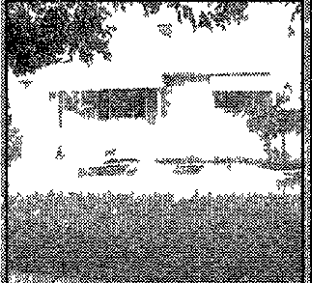















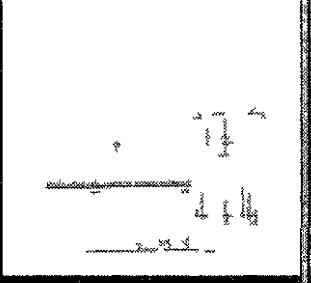

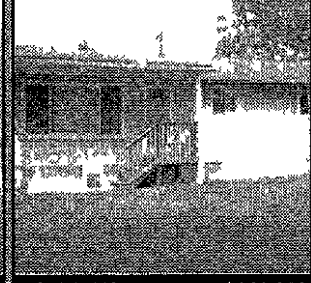
734-254-9077

OE08393671

REALTORS TO ADVERTISE ON THIS PAGE CALL 734-953-2176

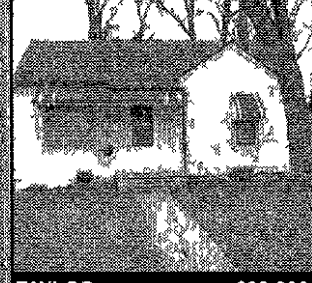
COLDWELL BANKER **SCHWEITZER REAL ESTATE**
Residential Real Estate

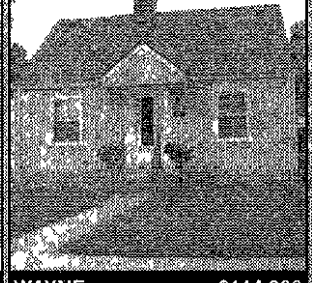
#1 Coldwell Banker in Michigan

 <p>BIRMINGHAM \$999,500 Beautiful High End Newer Construct on Near Bham Co Gourmet Kit Flowing Floor Plan Extensive Use of Granite & Ceramic Excellent Den/office Space On Entry Level Mstr Ste W/Bonus Rm Except on a Neighbor hood MLS# 25169360 248 347 3050</p>	 <p>CANTON \$449,900 3400 sq ft w/ wlg slnd kt mple cbnts & work stat Upgraded crmc foyer kt & pvd m 1s f w 9' dgs & r n m d ngs Form LR DR cthd mstr suite w/H&H WIC grdn tub Lg fin bsmt w/half BA Overzd crnr lot MLS# 25151226 734 453 6800</p>	 <p>CANTON \$399,900 Fabulous 4 BR 2 1 BA colonia n Heritage Farms Lght bright kt nook w/H&H WIC 2 sory farm y room w/gas replace Master w/jetted tub & fash on bath Neutral Full basement 3 car gar Estate sized lot MLS# 25163572 734 453 6800</p>	 <p>CANTON \$364,900 Fabulous 4 BR 2 1 BA colonial Lg lot back ng to commons & woods Spacious kt hen nook w/H&H WIC floor FR open to kitchen w/FP Lux master suite 3 car S/E garage Walk to pool & clubhouse! MLS# 25163687 734 453 6800</p>	 <p>CANTON \$362,500 Phenomenal 4 BR 2 1 BA colonial on picturesque lot backing to large commons Hug kt hon & nook x master FR s open to kitchen w/FP Formal dng room Newer carpet Freshly painted MLS# 25168127 734 453 6800</p>	 <p>CANTON \$359,900 Perfect cul de sac locat on for th s ranch condo Golf course & wooded views from all vndws 2 BP 2 BA custom kitchen den & 2 car attached garage Full daylight basement A beauty MLS# 25143605 734 453 6800</p>	 <p>CANTON \$217,900 Brck Detached Condo Tastefully Decorated & Ready To Move In Nicely Landscaped Door Wall In Spacious Kit To Deck Large Fam Room W/ Gas F replace Large Mstr Suite w/ Full Bath & Walk n Closet Full Basement MLS# 25166286 248 347-3050</p>
 <p>CANTON \$174,900 Lots Of Updates Including Tea off Roof With Architectural Shingles Furnace And C/a Newer Windows A m m trim concrete Drive & Appliances Hardw Floors Tiled Bsmt FP In Fam Rm W/gas Log Fenced Yard MLS# 25189106 248 347 3050</p>	 <p>CANTON \$129,900 Crisp clean 2 bdrm 1 5 bath town house Open flr plan skylts over star & ma n bath Bay wndw n breakfast area gas fp partially fin bsmt Apps stay New roof & road paving retn shed deck Prv entrance MLS# 25169958 734-453 6800</p>	 <p>COMMERCE \$499,000 Welcome Home To Ths Beaut ful 4 Bed 3 1 Bath Colonial Gourmet Kitchen W Granite Counters Is Any Chef's Dream 2 way F replace Forma Dining Rm Huge Family Rm Master BD W/ private Bath Cathedral Ceilngs MLS# 25164688 248 347 3050</p>	 <p>DEARBORN HGTS \$369,000 3 BR 2 BA ranch w/over 2000 sq ft Large kitchen w an abundance of counter space Huge bsmt w plenty of room for roller bladng n the winter Large backyard w patio for summer fun 1st flr Indry & 2 car att gar MLS# 25160663 734 453 6800</p>	 <p>DEARBORN HGTS \$137,000 Move n perfect 3 BR 2 BA b ck ranch w/HWH & plaster wals LR w/beautiful bay wndw updated kt open to dng area Updated baths wndw turn hwn F n LL w/g rec rm Indry rm & tons of storage 22x24 garage MLS# 25164320 734 453 6800</p>	 <p>DETROIT \$78,500 Attractive 3 Bedroom 1 1/2 Bath Ranch W th Newe Sding F nished Basement Central Air Large 2 Car Garage W/ opener La ge Fenced Backyard That Offers Plenty Of Privacy & More A! At An Affordable Price MLS# 25164665 248 347 3050</p>	 <p>FARMINGTON HILLS \$249,900 Ths s a true diamond in the rough Seller has done some of the updates includng new vnyl siding newer w n dows refaced kt cabinets & ripping out overgrown landscaping Great area w/large lots MLS# 25167632 248 347 3050</p>
 <p>GARDEN CITY \$169,900 First time buyers dream! You w not find a better value Ths 3 BR 2 BA home w/fin basement & heated garage s truly move n ready Newer roof furnace AC Wallside wndws updated kt & baths Freshly painted MLS# 25163426 734 453 6800</p>	 <p>GREEN OAK \$40,000 Spectacular Tuscan Style Custom Home W/fin Lake Views! Prem um Limestone Elevat on Unfin Extra Deep W/lo W/ions Of W ndws Dua Star cases Exter Recessed Lghtng To Granite Counters 1st Flr Mstr MLS# 25150587 248 347 3050</p>	 <p>LINCOLN PARK \$104,900 Large Lot 40x174 Large K tchen 21x11 Large Mbr 14x12 Newly Landscaped Ranch Beautiful Hard wood Floors Remodeled Bath Roof Was a Tear Off In Furnace & A/c New Fabulous Family neighborhood MLS# 25129997 248 347 3050</p>	 <p>LIVONIA \$329,900 Absolutely Gorgeous Sprawlng Ranch On A most An Acre Cust Gourmet Kit W/restaurant Appas All GE Appli ances Walk n Pantry Ceramic Floors & Recessed Lghts Great Landscapng includs 2 Large Stone Terraces MLS# 25164340 248 347 3050</p>	 <p>LIVONIA \$280,000 Detached Ranch Condo Located On a Cul de sac Open Flr Pan Hrdwd Floors 12 Ceilngs Apple Frplc W/Oak Mantle Waste Suite Has Jetted Tub & Its Own Shower 2nd Br Has Its Own Bath 6 Panel D s MLS# 25160610 248 347 3050</p>	 <p>LIVONIA \$274,900 Well Maintaned Lr Forma Dr 1st Flr den & Fam n w/ pl Spacious Eat n Kt White Cabnets M cro & Dishwasher 2 Doorwalls To Mult level Deck Bsmt W loads Of Storage 97 furnace Ac & Roof MLS# 25146215 248 347 3050</p>	 <p>LIVONIA \$269,900 New construct on! 4 BR colonial w/ great locat on Maintenance free exte r & ge lot Spacious kitchen w/nook & breakfast ba 2 5 baths w/Corlan cnt s Lge LR w/gas FP & bay wndw 2nd flr Indry & loft 2 car gar MLS# 25168537 734 453 6800</p>
 <p>NORTHVILLE \$497,000 4 BR 3 5 BA home bilt n 2004 filled w/ custom touches HDWD flr own mid ngs form LR & DR Grmie kt w/c s dng FP to FR Mstr w/2 WIC ceramic ba & jetted tub Prof Indscp yd w/2 tered deck paver patio & walkway MLS# 25153238 734 453 680</p>	 <p>NORTHVILLE \$199,900 Wooded r vfront settng for ths 2 BR condo n downtown Northvle Move rght n! Vaulted ceilings FP 1 5 baths att garage balcony & appliances Included Charming Brownstone ac oss from histor c C derm ll MLS# 25163248 734-453 6800</p>	 <p>NOVI \$900,000 Gorgeous Private Cape Cod Nestled In Woods W/pond On 2 23 Acres! New! Lscapng & Circu ar Dr Fab Ext a Deep W/lo W/bm Fr W 2 way Fp HM Theatre Bath Rec & Work Rm Spacious Gr W/2 way Fp To Huge K1 MLS# 25145142 248 347 3050</p>	 <p>NOVI \$725,000 Totally emodeled home nestled n woods on 2 04 acres Remodeled kt w/42 maple cab w/granite counters & vaulted cedar ceilng 100 project on TV screen n frpoured concrete 2nd gar Florida rm w/900 gal hot tub MLS# 25159800 248 347 3050</p>	 <p>NOVI \$579,000 Breckenrdge Mode In Broadmoor Pa k On Awesome Private Lot Backng To Preserve 9 Ft Ceilngs On 1st Fidual Sta ceases 3 5 Cargarge Fu W o W/bath Rough ns br dge Overlooks 2 story fr W/ p hwd Floors t/o MLS# 25154879 248 347 3050</p>	 <p>NOVI \$559,900 Stunning 5 BR cape cod Qua ty feat ures & custom upgrades t/o Grmt k! w/lge nook island hearth oom & drwall to gorgeous screened n po ch Jenn are appis nc 2 story foyer vault ed great rm & 9 ft cgs t/o MLS# 25164764 734 453 6800</p>	 <p>NOVI \$450,000 Immediate Occupancy! On Large Lot W/southern Exposure To Enjoy Th In ground Pool Mstr Suite w/Sitting 2 story Foyer Hwd Fls In Foyer Half Bath & K1 P Fin Bsmt W/rec Rm & Partial Kt 2 5 Car Garage MLS# 25154837 248 347 3050</p>
 <p>NOVI \$399,000 Beautiful end unit condo located n Island Lakes of Novi \$10 000 lot prem um convenient to everything w/club house pool & tennis courts Fu fin bsmt & att 2 car gar Almost \$70 000 n extras Turnkey property! MLS# 25151238 734 453 6800</p>	 <p>PLYMOUTH \$1,399,000 Downtown Plymouth estate home All brick 3 story 5 BR 5 1 BA colonial complete y remodeled n past 2 years Gourmet kitchen nook w/granite Every bedroom is a suite 5 6 car garage Prof fin wa kout MLS# 25148099 734 453 6800</p>	 <p>PLYMOUTH \$627,500 Execu ve 4 BR 4 2 BA colonial on park like settng back ng to commons Gigant c kitchen Open FR w/FP Lux maste w/FP LR w/FP BRs are enor mous Fin shed LL w/ktchenette & bath MLS# 25141420 734 453 6800</p>	 <p>PLYMOUTH \$459,900 3-4 BR w/opt study 3 full BA custom bilt br ck ranch w/in law ste GR w/gas FP & 10ft clgs 9ft clgs on rest of 1st flr Mstr w/soaring o g Ande sen wndws Daylts bsmt w/9ft cgs Overzd gar Pick co ors & cbnts MLS# 25162198 734 453 6800</p>	 <p>PLYMOUTH \$429,900 \$5 000 ho day bonus to buyers at c os ng Charming home w ma or updates nc off wndws s dng pmbg & etrcal 2 sto y addtion c eatng huge mstr & FR 1st flr offc New 2 car ga age w/nt finished 2nd story MLS# 25160503 734 453 6800</p>	 <p>PLYMOUTH \$359,900 New construction Now s you chance to own new construct on near downtown Plymouth while payng lower townshp taxes Brazil an cherry HDWD floors maple cabnetry 1 ep ace deck sod GA & 2 car garage MLS# 25148810 734 453 6800</p>	 <p>PLYMOUTH \$159,900 Great Duplex Priced Right! Investors Take Notice Wonderful In Town Locat on Near Schls Shopping Chu ches Ths Duplex Is In Great Cond Newe Roof 2 Bm Each Side dont Snooze on Ths One! MLS# 25077915 248 347 3050</p>
 <p>PLYMOUTH \$135,900 The Nest Location In Pinewood Village 2 Bed 1 1/2 Bath Upper Ranch W/ament es Ga ors Pr v Entrance Totally Neutral Great Rm W/cathedral Ceiling 2 Skylights Fireplace Shero Oak Kt Large Mbr W/w/c MLS# 25166397 248 347 3050</p>	 <p>ROMULUS \$146,900 Stunning 1 1/2 acres! Enjoy the magnif cant views & tranquil settng on peace ful low traffc street Property offers plenty of room for a garage or pole barn Updates roof(04) newer wndws oak kt remodeled bath MLS# 25167088 734 453 6800</p>	 <p>ROMULUS \$129,900 Open Flr Plan Situated On Quarter Acre Lot Great Starter Home W th Nice Finished Basement Which Includes Open Family Room With Bar Spacious Laundry Area And Additional Storage 3 5 Car Garage With Tall Ceilings MLS# 25137575 248 347 3050</p>	 <p>ROYAL OAK \$76,900 Updated Condo! Freshly Painted T/o Kt n Updated W/ r dge Range Cabnets Counte Tops Disposal T e Floor S nk/auceot Bthrm Updated Updated W ndws & Lght F stures T/o MLS# 25068609 248 347 3050</p>	 <p>SOUTH LYON \$389,900 A perfect 10 Located on a prem um cul de sac ths home is better than brand new Your best buyer w l enjoy the profess on y landscaped yard custom window treatments & decorated lke a model interior! MLS# 25121903 734 453 6800</p>	 <p>SOUTHFIELD \$234,900 Park like ot w/ove 1/3 acres kitchen w/cherry wood cabinetry Corlan counte rs & ceramic flrlng & dng rms w/hwdwd frs Flex m off kitchen w/nt frpl family rm w doorwall to deck Rec m n bsmt Newer wndws MLS# 25155184 248 347 3050</p>	 <p>TAYLOR \$159,900 New Construct on End Unit Mstr Suite W/Walk In Closet & Bath 1st Floor Laun Counte Tops Ceramic 36 Gas Log F replace W/Wood Mantle & Ceramic Su round 2 Cargarge W/ Drywall & Ceiling MLS# 25147934 248 347 3050</p>
 <p>TAYLOR \$92,900 Ranch conven ently located to free ways restaurants stores etc Home is neutral w/updated kt newer crpt new roof n 99 Lge breezeway that s heated & could be used as a family room 1 5 car attached ga age MLS# 25168587 734 453 6800</p>	 <p>WATERFORD \$149,900 Newer end unit condo that backs to wooded privacy Bult n 1997 w/1242 sq ft 2 BR & 1 5 baths GR w/vau ted ce l ngs & gas FR kitchen w/ceramic floor nook & doorwall to deck 1 car garage & basement MLS# 25165054 734 453 6800</p>	 <p>WAYNE \$114,900 Cozy home 3 BR bungalow w/updates nc cof s dng Wa side wndws water heater furnace elect cal & new carpet ng upstals Located near parks ele mentary school & community center Home warranty ncuded MLS# 25131995 734 453 6800</p>	 <p>WEST BLOOMFIELD \$289,999 Pr ced Cons derab y Below Appraisal & Sev Fabulous Backyard View Walkout Basement Great Floor Pan W/very Large Rooms Very Private Settng Backng To Large Commons N ce Size Lot (111x142) Home Warranty MLS# 25163220 248 347 3050</p>	 <p>FARMINGTON HILLS \$445,000 Colon al w 2 entry drs dua sta ceases wooded Now d men roof (tearoff) 04 c o drve(04) 18x18 tile n hall & kt off n I Andersen wndws t/o 2 furns & c/a Fla rm off kt w 4 sklgts & pat os 2 fs hwd foyer & dr 10 ft ce ngs n unfn bsmt MLS#248 348 3050</p>	<p style="text-align: center;"><i>Are you serious about a career in real estate?</i> We are serious about your success!</p> <ul style="list-style-type: none"> • Free pre licensing classes • Exclusive success systems training and coaching programs • Earn while you learn • Variety of commission plans including 100% • Join the #1 Coldwell Banker affiliate in the Midwest <p style="text-align: center;">Contact Lloyd O'Dell at 248-347-3050</p>	

If it's on the market, it's on our website... www.cbschweitzer.com
Northville 248-347-3050 • Plymouth 734-453-6800
 Real Estate Classes & Training, 888-414-8330 Or visit our web site, and sign up online.

Following key steps makes loan process easier

Have you ever been faced with a daunting task that you know is sure to sap your time, effort and energy, but you know it must be done? Too often, that formidable task keeps slipping to the bottom of your prioritized stack. Most of us would rather knock out ten simpler list items than tackle "the monster."



Timothy Phillips

Your mortgage loan officer is really no different than you are in that regard. There are some simple things you can do to make sure your file gets "top priority" on your loan officer's list.

An easy way to get your file off to a good start is to prepare to complete a bulletproof loan application. Initially, your lender will need the complete name, current address and social security numbers for each borrower to pull their credit histories.

For most of my clients, I check credit during our very first phone conversation. If your credit report is a bit bruised up, your loan officer may immediately give you specific tasks - I call them "homework assignments" - that will help him or her either clear up those blemishes, or at least mitigate their impact.

Some of these credit-related tasks may include supplying copies of divorce or bankruptcy papers, proof of paid collections, or copies of previously discharged mortgages. These requests may seem trivial (or

even painful), but leaving them undone may result in your loan being left undone. Do these things right away.

During this pre-application phase, plan on also digging out some other documents, including your past two pay stubs, your most recent banking and investment statements, and your past two years' W2s or tax returns, if you are self-employed. Renters should also compile their landlord information for the previous two years, and real estate investors should list property and lien information on each of their properties.

Today's TIMBIT! Getting your mortgage approved efficiently requires a team effort between you and your loan officer. You will usually receive priority service from your mortgage loan officer if you give the same energy in return.

Timothy Phillips is a mortgage banker and newspaper columnist. Visit www.phillipsHQ.com for free information online or call him toll free at (866) 369 4516. Homebuyers should always consult a professional for guidance specific to their situation.

These are the Observer & Eccentric area residential real estate closings recorded the weeks of July 5 & 2005 at the Wayne County Register of Deeds office. Listed below are cities, addresses and sales prices.

City	Address	Sale Price
Canton	4063 Amanda	\$230,000
Canton	41558 Bedford	\$118,000
Canton	4064 Bridgeview	\$52,000
Canton	475 Canford Park	\$412,000
Canton	8301 Chatham	\$608,000
Canton	8446 Chatham	\$313,000
Canton	46525 Creekside	\$300,000
Canton	40761 Deer Pines	\$85,000
Canton	40843 Deer Pines	\$85,000
Canton	39542 Dorchester	\$300,000
Canton	7474 Emerson	\$250,000
Canton	43761 Fredericksburg	\$175,000
Canton	43900 Fredericksburg	\$178,000
Canton	45689 Graystone	\$184,000
Canton	42289 Hanford	\$213,000
Canton	46271 Hanford	\$265,000
Canton	2176 Hogan	\$219,000
Canton	44676 Jeffrey	\$230,000
Garden City	427 Lenox	\$462,000
Garden City	42595 Lilley Pointe	\$127,000
Garden City	45647 N Stonewood	\$187,000
Garden City	8573 New Haven	\$355,000
Garden City	1975 Pinecroft	\$174,000
Garden City	1993 Pinecroft	\$171,000
Garden City	4744 Pond Run	\$282,000
Garden City	2203 Preserve	\$248,000
Garden City	43061 Providence	\$195,000
Garden City	42462 Saratoga	\$128,000
Garden City	41452 Singh	\$387,000
Garden City	42425 Somerset	\$200,000
Garden City	29590 Balmoral	\$137,000
Garden City	5914 Helen	\$146,000
Garden City	5694 Henry Ruff	\$190,000
Garden City	29414 Meadow	\$144,000
Garden City	30075 Rosslyn	\$219,000
Livonia	15197 Arden	\$155,000
Livonia	31782 Bretton	\$188,000
Livonia	38973 Dover	\$215,000
Livonia	16516 Fairway	\$270,000
Livonia	31608 Gable	\$192,000
Livonia	18675 Hillcrest	\$182,000
Plymouth	29622 Mason	\$191,000
Plymouth	19450 Rensellor	\$190,000
Plymouth	20105 Saint Francis	\$93,000
Plymouth	9810 Shadyside	\$183,000
Plymouth	37619 Summers	\$216,000
Plymouth	14233 Sunbury	\$155,000
Plymouth	14628 Taylor	\$110,000
Plymouth	16042 Woodring	\$259,000
Plymouth	15117 Yale	\$239,000
Plymouth	11647 Butternut	\$200,000
Plymouth	42506 Hammill	\$162,000
Redford	12903 Brady	\$144,000
Redford	16361 Glenmore	\$142,000
Redford	25130 Graham	\$175,000
Redford	19354 Kinloch	\$108,000
Redford	19133 Lexington	\$164,000
Redford	19379 Lexington	\$198,000
Redford	19995 Lexington	\$123,000
Redford	17021 Macarthur	\$160,000
Redford	9054 Mercedes	\$186,000
Redford	18851 Negaunee	\$132,000
Redford	24931 S Sylbert	\$153,000
Redford	8892 Virgil	\$179,000
Westland	26705 W Chicago	\$137,000
Westland	15863 Woodworth	\$133,000
Westland	33716 Arrowhead	\$151,000
Westland	31741 Birchwood	\$130,000
Westland	34742 Birchwood	\$151,000
Westland	7453 Deering	\$88,000
Westland	34939 Donnelly	\$118,000
Westland	2214 Ellsworth	\$113,000
Westland	34640 Florence	\$205,000
Westland	34640 Florence	\$87,000
Westland	38129 Greenwood	\$104,000
Westland	31225 Hivley	\$150,000
Westland	8196 Huntington	\$72,000
Westland	6394 Pembroke	\$169,000
Westland	1331 Rahn	\$135,000
Westland	35354 Rosslyn	\$105,000
Westland	330 S Byfield	\$157,000
Westland	2314 S Christine	\$134,000
Westland	4926 S Inkster	\$50,000
Westland	4926 S Inkster	\$124,000
Westland	2038 S Parent	\$120,000
Westland	1147 Sharon	\$145,000
Westland	35127 Webster	\$87,000

THE OBSERVER & ECCENTRIC MORTGAGE MONITOR													
	30 Yr	Pts	15 Yr	Pts	Other		30 Yr	Pts	15 Yr	Pts	Other		
1st Choice Mortgage Lending	(734) 489-0782	5.5	0	5.5	0	J/A	GMAC Mortgage Corp	(900) 888-1622	5.625	0	5.75	J/A/V/F	
1st National Bank in Howell	(517) 545 2207	6.125	2	5.875	2	J/A	Golden Rule Mortgage	(800) 991 9922	5.5	1.75	5	1.625	J/A/V/F
A Best Financial Corp	(800) 839-8919	5.375	2.125	4.375	2.125	J/A	Goldstar Mortgage	(800) 724-1074	5.875	0	5.875	0.25	J/A/V/F
AAXA Discount Mortgage	(877) 728 3569	5.5	2	5	2	J/A	Group One Mortgage	(734) 953-4000	6.125	0	5.75	0	J/A/V/F
AFI Financial	(877) 234-0600	5.875	0.125	5.5	0	J/A	Home Finance of America	(800) 253-5623	5.875	0	5.375	0	J/A
America's Premiere Mortgage	(800) 585 8730	6	0	5.5	0	J/A/V/F	Honzon Financial Group	(866) 538 7887	5.625	2	5.125	2	J/A
Amerplus Mortgage Corp	(248) 740-3323	5.875	0.125	5.5	0	J/A	JMC Mortgage Corp	(248) 489-4020	5.625	3	5.125	3	J/A
Bay Pointe Mortgage Corp	(248) 652-3598	NR	NR	NR	NR	J/A/V	Keystone Mortgage	(866) 539 3733	5.5	2.25	5.25	1.75	J/A
Brighton-Commerce Bank	(810) 220-8846	5.875	0	5.5	0	J/A	LaSalle Bank Midwest	(800) 460-3500	5.375	2	5.5	2	J/A/V/F
Brinks Goldstar Mortgage	(800) 785-4755	5.625	0.875	5.25	0.875	J/A/V/F	Lira Financial	(586) 228 0900	6	0	5.5	0	J/A/V/F
Capital Mortgage Funding	(248) 569-7283	5.75	2.5	5.5	2	J/A/F	Macomb Schools & Gov. C/U	(586) 263-8800	5.625	2	5.125	2	J/A
Captiva Group Mortgage Co	(248) 682 8643	5.75	0.25	5.5	0	J/A	Mainstreet Mortgage	(800) 900 1313	6	0	5.625	0	J/A/V/F
Centerbrook Mortgage	(248) 851-4450	5.75	0.25	5.5	0.125	J/A	Manufacturers	(586) 777-1000	5.75	1	5.625	1	J/A
Charter One Bank	(800) 342 5336	6.5	0	6	0	J/A/V/F	Mortgages by Golden Rule	(800) 991 9922	5.75	0.5	5.25	0.75	J/A/V/F
Client Services by Golden Rule	(800) 569-5805	5.625	1.125	5.125	1.25	J/A/V/F	National City Bank	(888) 825-0825	5.875	1.5	5.375	1.625	J/A
Co op Services Credit Union	(734) 486 6113	5.875	2	5.375	2	J	Northlawn Financial	(248) 988-8488	5.875	0	5.5	0	J/A/V/F
Community Bank of Dearborn	(734) 981-0922	6.25	0	5.75	0	J/A	Pathway Financial LLC	(800) 726-2274	6	0	5.5	0	J/A/F
Credit Union One	(800) 544 5567	6.25	0	5.875	0	J/A	Peoples Mortgage	(800) 730 5087	5.875	0.125	5.5	0	J/A*
Dearborn Fed. Savings Bank	(313) 585-3100	5.25	0	5.875	0	A	Premiere Mortgage Funding	(248) 355-2900	6	0	5.75	0	J/A
DFCU Financial	(800) 739 2770	5.875	2	5.375	2	J/A	Prime Financial Group	(248) 203 7010	6	0	5.5	0	J/A/V/F
ERB Financial	www.ERBFIN.com	5.375	0	5.5	0	R	Shore Mortgage	(800) 878-3663	5.8	0	5.5	0	J/A/V/F
Fifth Third Bank	(800) 792 8830	6.125	0.375	5.75	0.125	J/V/F	Sterling Bank & Trust	(800) 928-5826	6.125	0	5.75	0	J/F
First Alliance Mortgage Co	(800) 292-7357	6.25	0	5.875	0	J/A/V/F	United Mortgage Group	(586) 268-9500	6	0	5.5	0	J/A
First International Inc	(248) 258 1584	5.875	0	5.5	0	J/A	York Financial Inc	(888) 839 9675	5.875	0.75	5.375	0.75	J/A

Above information available as of 11/29/05 and subject to change at anytime. Rates are based on \$150,000 loan with 20% down. Jumbo rates. ARM rates specific payment calculations and most current rates available Fridays after 2:00 P.M. at www.rmcreport.com. All participating lenders are Equal Housing Lenders. Key to Other Column: J = Jumbo, A = Arms, V = VA, F = FHA, R = Reverse Mtg, and NR = Not Reported. © Copyright 2005 Residential Mortgage Consultants, Inc. All Rights Reserved.

COLDWELL BANKER

PREFERRED, REALTORS

DISCOVER THE DIFFERENCE

PROFESSIONALISM. SATISFACTION. RESULTS.

View

Thousands of available homes in your area

On our website @ www.cbpreferred.com

CUTE NEW CONDO Gorgeous newer condo on a low traffic street. Clean bright and neutral decor. Direct access garage. Stove and refrigerator included. Why rent when you can own in a sought after Canton area? \$159,900 (P 885CA)

EYE CATCHING FEATURES In this newly constructed condo offering a ceramic floor, 1st floor laundry, hardwood and autumn maple kitchen, dual toned paint, master w/ garden tub, treated deck & more. \$209,900 (C-472GL)

SMART BUY Move in and settle down in this awesome 4 bedroom, 2.5 bath colonial situated on a huge lot that measures to almost half an acre! Updated roof, furnace, electrical, window paint, fixtures and more. Home warranty too! \$179,900 (P 314KE)

NOT JUST NEW CONSTRUCTION This is a quality constructed Redford ranch with high eff. furnace and air all kitchen appliances, a 9 foot basement, 3 bedrooms, 2 baths and more. Still time to pick your own colors. Call now \$154,900 (C 945SA)

NICELY DONE RANCH Many upgrades in this beautiful Pulte built ranch. Hardwood in the great room, dining & kitchen, new carpeting in the bedrooms, extensive landscaping w/ large brick paver patio. Over 1600 sq ft. \$257,000 (P 673TI)

ESTATE SIZED LOT Overlooking adjoining commons with impressive details and upgrades throughout. Well planned, beautiful landscaping deck w/ hot tub, finished basement, 4 bedrooms (possible 5th) and 3.5 baths. \$510,000 (P 118ME)

LOOK NO FURTHER! Than this exquisite 4 bedroom colonial in Canton's Central Park. Grand entry, hardwoods, gourmet kitchen, formal areas, fireplace, a superb master and an oversized lot! \$379,900 (C 077LI)

A NATURAL BEAUTY Custom ranch on 5 acres in Canton. Features include 9 ceilings, egress windows, euro style island kitchen w/ granite, ceramic floors, side entry garage and an out of this world master. Wow! \$449,000 (C 250MC)

NEED A LOT OF SPACE? This home has 3 huge bedrooms upstairs plus a storage room, 1 full bath, dining and living room open to the breakfast nook, big kitchen w/ walk in pantry to the Florida room overlooking the backyard. 2233 sq ft. \$145,900 (P 274EL)

STOP RENTING! This home is ready to be lived in! Nice size living room, 2 bedrooms on the first floor and a full bath. Huge bedroom upstairs with an extra 6x7 area. Basement garage and a cute screened in porch to enjoy all summer. \$74,999 (C 946EV)

THIS ONE WON'T LAST Brick ranch with 3 bedrooms on a quiet street in Livonia. New roof, furnace and central air. Fabulous 3 season room in a very pretty fenced yard. Just move in and enjoy! \$159,900 (P 863WE)

A HOME FOR ALL SEASONS Extend your summer in the 3 season sunroom with a hot tub or cozy up to the family room fireplace in the fall. This well cared for home offers formal living areas, oak kitchen w/ Pergo floor, a private master and more. \$259,900 (C-490AA)

HILLTOP TREED SETTING 4 bedroom ranch on a beautiful 1.6 acre setting. Atop the hill you'll find an impressive master, an oversized kitchen w/ center island/snack bar, finished walkout, 3 inviting decks and a 3 car garage. Like new presentation throughout. \$499,900 (P 665WA)

HOME SWEET HOME One of the biggest homes in the neighborhood with a large upstairs, dormer, finished basement w/ rec area. Updated roof, carpet, furnace & more. Central air, appliances and a garage. \$120,500 (C 092EL)

ALL ABOUT THE SETTING Backing and sliding to hillsides & woods, this Plymouth condo has 3 bedrooms each with a bath, 2 kitchens, lot overlook, 25 ft snack bar, central vac, intercom system, morning porch and notable ceiling detail. \$535,000 (P 401BE)

AMAZING BRICK RANCH Beautifully maintained Dearborn Heights home with a family room, trepane formal living & dining rooms and major updates that include sprinklers, windows, plumbing, furnace and more. \$174,900 (C 261MI)

FIRST TIMED OFFERED Maintenance free brick ranch featuring newer windows, a finished basement, newer roof, fenced yard, updated kitchen with appliances, hardwood floors and a home warranty! Can't be beat for only \$145,000 (P 825SAL)

THE TOTAL PACKAGE Quality brick ranch with 3 bedrooms/2.5 bath. Large floor plan offering rich hardwood floors, huge eat in kitchen, appliances, family rm, fireplace, finished basement, 1st floor laundry, air attached garage and fenced yard. \$250,000 (P 448SH)

LOCATION! CONDITION! PRICE! All 3 are perfect and you even get a park like setting in a cul de sac! Beautifully maintained 2 story with a fabulous kitchen, finished basement, 1st floor laundry and lots of updates. Must see! \$225,000 (C 245TE)

CUTE STARTER HOME Turn key condition with neutral décor, wonderful curb appeal and a huge updated oak kitchen. New vinyl windows, air, 6 panel doors, 1st floor laundry and kitchen appliances stay. Even has a pool! \$107,900 (P 730DE)

EASY CONDO LIVING At a great price! Location plus charm abounds in this 2 bedroom, 1.5 bath condo. Updates include the deck, carpeting, kitchen and paint. Close to the schools, shopping and major freeways. Downriver area. \$124,000 (P 703RO)

IMMACULATE PRINCETON MODEL 2 story foyer, lighted crown moldings, large family room w/ fireplace, hardwood floors, large master w/ vaulted ceilings, fashion soaking tub and WIC. Finished basement w/ bar, beautiful deck and a premium lot. \$306,000 (C 748SH)

JUST TURN THE KEY To this welcoming starter home with 2 bedrooms and 2 full baths. Formal living room plus a family room in a great open floor plan. Numerous updates, privacy fence, large front porch and a great location. Call today! \$123,500 (P 781PU)

LOVELY HOME 4 bedroom Cape Cod with an updated garage door, landscaping, furnace, hwh and vinyl siding. Big country kitchen, dining area, w/ bay window, master with walk in closet. Don't miss this one! \$69,900 (C 573EV)

NORTHVILLE/NOVI
(248) 305-6090

CANTON
(734) 392-6000

FARMINGTON
(248) 478-6022

WESTLAND/GARDEN CITY
(734) 392-6000

PLYMOUTH
(734) 459-6000

LIVONIA
(734) 425-6060

Statute impacts state residents

Q I understand that there is a new zoning statute in Michigan regarding contract or conditional zoning, can you be of any help?

A Governments land use planners, property owners and developers have a new tool at their disposal to assist in reaching compromise regarding development or re-development of land in Michigan. The new legislation which pertains to various zoning acts affecting townships, cities, villages and counties is essentially identical and generally provides as follows:
1 An owner of land may voluntarily offer in writing and the (township, or city, or village or county) may approve, certain use and development of the land as a condition to a rezoning of the land

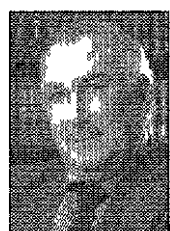

Real Estate Inquires
Robert Meisner

or an amendment to a zoning map
2 In approving the conditions under subsection (1), the (township, or city, or village or county) may establish a time period during which the conditions apply to the land. Except for an extension under Subsection (4), if the conditions are not satisfied within a time specified under this subsection, the land will revert to its former zoning classification.
3 The (township, or city, or village or county) shall not add or alter the conditions approved under subsection (1) during the time period specified under subsection

(2)
4 The time period specified under subsection (2) may be extended upon the application of the land owner or approval of the (township, or city, or village, or county), and
5 A (township, or city, or village or county) shall not require a land owner to offer conditions as a requirement for re-zoning. The lack of an offer under subsection (1) shall not otherwise affect a landowner's rights under the act, the ordinances of the (township, or city, or village or county) or any other laws of the state.
 You are best advised to consult with your real estate attorney concerning the ramifications of this new and relatively expansive zoning statute.

Robert M Meisner is a lawyer and the author of *Condominium Operation Getting Started & Staying on the Right Track* second edition. It is available for \$99.95 plus \$1 shipping and handling. He also wrote *Condo Living A Survival Guide to Buying, Owning and Selling a Condominium* available for \$24.95 plus \$5 shipping and handling. For more information call (248) 644-4433 or visit rbmeisner@meisnerassociates.com. This column shouldn't be construed as legal advice.

WEIR MANUEL

REALTORS

Birmingham 248-644-6300
 Plymouth 734-455-6000
 Rochester 248-651-3500
 West Bloomfield 248-851-5500

<p>CANTON \$408,000 3440 1166175170285</p>	<p>NORTHVILLE \$429,900 344556000 11638075168671</p>
<p>PLYMOUTH \$370,000 3415000 11880075148619</p>	<p>GARDEN CITY \$245,000 344556000 1163807512794</p>
<p>PLYMOUTH \$221,900 3440000 119617513800</p>	<p>WAYNE \$169,900 344556000 1177817516119</p>
<p>PLYMOUTH \$167,900 3440000 1596175152561</p>	<p>NOVI \$142,000 344556000 1163807516119</p>

For a complete list of open houses and more than 30,000 listings visit www.weirmanuel.com

Featured

HOMES OF THE WEEK

Presented By

REMERICA

INTEGRITY REALTORS

<p>CANTON - Beautiful 2400 sq. ft. on oak that backs to creek. Great room w/ cathedral ceilings and a natural fireplace. Large kitchen w/ island and hardwood floors. 1st floor laundry. 6 pane doors formal dining room. Master suite has walk in closet and master bath. Finished bsmt. underground sprinklers. C/A & more. \$315,000 (38TRF)</p>	<p>LIVONIA - Well maintained 3 bed brick ranch on a quiet cul de sac location. Basement sprinklers. 2 car garage bay window updated kitchen including oak cabinets. Pergo floors and newer appliances. Kitchen opens to generous family room w/ gas fireplace. Doorway to deck w/ retractable awning. \$234,900 (99BA)</p>
<p>DEARBORN HGTS - Gorgeous 3 bed 1.5 bath brick ranch. Family room w/ fireplace. Attic fan. Hardwood floors. 6 panel doors. Double sinks in bath. Oak kitchen cabinets. Pantry. Pella windows. Large closets. Beautiful sunroom. Finished bsmt. private fenced yard. Newer electric. roof shingles. gas age. \$235,000 (16TMI)</p>	<p>LIVONIA - Nest home in the neighborhood. Immaculate 3 bed 1.5 bath ranch with brand new carpeting thru out. Florida room. 2 car garage. Beautiful fenced yard. Freshly painted extra large family room overlooking the new Florida room. Remodeled kitchen and bath. Newer roof shingles. \$232,000 (34HOU)</p>
<p>Livonia - Beautiful 3 bed 1.5 bath brick ranch on a gorgeous landscaped corner lot. Oak trim and doors in all rooms. 2 car garage. Sprinklers. ssmt. open floor plan. From the kitchen to family room overlooking a beautiful California stone wall fireplace. Patio w/ strata. swimming and private fenced. \$254,900 (95BA)</p>	<p>Livonia - Adorable 3 bed 2 bath brick ranch. Newer roof. New windows. garage door. remodeled kitchen and bath. all ref. shd. hardwood floors. 2nd full bathroom in finished basement. Home war. any 2 car garage. fenced yard. \$169,900 (12PER)</p>
<p>LIVONIA - Freshly painted 2 bed condo. Updates include remodeled kitchen with oak cabinets. new electrical service with breakers and new windows. Coved ceilings in living room and dining room. C/A bsmt. app. ances stay. very nice condition. Association fee includes water. \$91,900 (12MID)</p>	<p>Northville Twp - Spectacular waterfront estate! Built by Mosen on a premium cul de sac lot w/ views of 2 lakes in prestigious Stonewater sub. Granite gourmet kitchen. magnific. millwork thru out. 5th bdrm in the beautifully finished walk out lower level w/ granite kitchen and home theater. spacious deck. \$1,375,000 (59MIS)</p>

Read Taste for great recipes

Hometowne BUILDING CO.

Quality People Building Quality Homes

Three for FREE

Be home by the holidays, be on vacation for the New Year!

"THREE FOR FREE" new buyers may pick 3 of the 7 gift options for purchases between now and January 7th.

- Granite in the Kitchen
- Chef kitchen package
- Visa gift card or cash towards closing
- SS appliances package including refrigerator
- Premium laundry package
- Master bathroom upgrade
- Expense paid vacation

Hurry offer ends Jan. 7th.
 *Contact sales associate for details.
Information Centers
 Open Daily 11am - 6pm Closed Thursdays
www.hometownebuilding.com

REMERICA INTEGRITY

Two Locations for your Convenience
 Livonia and Northville
734-525-4200 • 248-912-9990
www.remericaintegrity.com

EARN EXTRA \$\$\$

Booming Real Estate Offices in Livonia and Northville are seeking outgoing Salespeople! Training Available.
Call Robert or Kim at:
734-525-4200 or 248-912-9990

<p>PLYMOUTH TWP 5 BEDROOM COLONIAL 1st floor laundry. Master suite has 2 walk in closets. Large lot backing to school playground. All important systems are updated. roof furnace. C/A vinyl windows. U G sprinklers & low maintenance exterior. (GRE57) \$309,900</p>	<p>CANTON HOME W/LOADS OF UPGRADES! Wonderful floor plan. Oversized 2.5 car garage. Front porch. Hardwood floors. raised island. custom lights. Crown moldings. 9 ceilings. custom windows. gas fireplace. master suite w/ jacuzzi. paneled ceiling. LL. plumbed upgr. elec. All appl. pre-inspected. (RIVE9) \$409,999</p>
<p>NORTHVILLE 4 BEDROOM 3 1/2 BATH COLONIAL. Cathedral ceiling. GR with gas fireplace. chef's kitchen. granite counters. butler's pantry. 1 bry. Master suite with bath. walk in closet or access suite. Jack N Jill. Walk out bsmt. (BIB92) \$699,900</p>	<p>PLYMOUTH WARM HARDWOOD FLOORS in LR & DR. Open kitchen is all new. Added counter space & pantry. Newer appliances. FR has gas flpic. Large laundry room. 2 full baths. one fully redone. other updates include roof siding windows. Great area. (SHA54) \$239,900</p>
<p>PLYMOUTH TWP COLONIAL BOASTS updates: hardwood in foyer kitchen & dining room. Updated kitchen w/ nook. Family room w/ corner flpic & built in bookcase. Newer windows & doorwall. Fully remodeled main bath. Free form patio on a spacious 80 yard. (MAP47) \$279,900</p>	<p>CANTON 3 BEDROOM COLONIAL 19x10 LOF 2 1/2 baths hardwood floors. 1st floor laundry. beautiful master suite. large WIC. granite bathroom. professional finished basement. w/wet bar. large corner lot. sprinkles. patio deck. (WEL52) \$309,000</p>
<p>CANTON RANCH IN POPULAR SUB. Walk to schools & parks. Open kitchen w/ fireplace. gas fl. & lots of cupboards. fireplace in FR. remodeled bath. Updated roof. windows. carpet. Finished basement w/ laundry storage area. Heated inground pool. (DER09) \$223,900</p>	<p>CANTON HOME AVAILABLE FOR LEASE! 2 story foyer w/ grand staircase. 2nd stairway to large kitchen. Granite and all kitchen appliances. LR w/ cathedral ceiling. den w/ FR doors. Hardwood floors. laundry w/ ceramic floor. master suite w/ cathedral ceiling. WIC. 3 car garage. Beautiful yard backs to 3 acres of common lot. (CHE23) \$2,000/mo</p>
<p>CANTON HOME IN GREAT FAMILY NEIGHBORHOOD! Comm. pool. club house and tennis courts. Hardwood in foyer. kitchen and nook. 02 windows. 03 new carpet. 04 all appl. to stay. inc. new dish. ref. sink. W&D. fresh paint. DR. w/ bay window. lead glass entry door. sprink. syst. visible fence. deck. hot tub. (REG72) \$299,900</p>	<p>CANTON QUAD W/LOTS OF ROOM! Ceramic entry. freshly painted kitchen. w/ new counter. oak floor. vaulted ceiling & doorwall. Formal DR. Large FR w/ flpic. Full kitchenette. Newer roof. C/A & landscaping. All appl. to stay. 3 car garage. Warranty. (KIN89) \$244,500</p>
<p>CANTON QUAD WALL 4 BEDS on upper floor. Kitchen w/ ceramic tile. new Dupont cherry fls. huge family room with flpic. Large laundry room. deck off master overlooking. Appl. stay. includes Home Warranty. (HANE0) \$229,900</p>	<p>CANTON 3 BDRM 1 1/2 BATH HOME. Lg corner lot. full bath redone. tear off roof. 00 and newer windows. Gas FP most appl. stay. part in bsmt. kt. updated w/ new floor. ceiling fans and more. Home warranty. (ME439) \$209,900</p>

SOLD

1365 S. Main, Plymouth
 or Visit us on the web...
www.GMACKee.com

(734) 451-5400

Trusted Advisor
 Skilled Negotiator
 Expert Facilitator
 Service You Deserve. People You Trust.

<p>STONEGATE POINTE</p> <p>NORTHPOINTE</p> <p>PONTIAC From \$179,900 248.334.7900</p> <p>DEARBORN AREA From \$119,900 313.381.7900</p>	<p>IRISH RIVER</p> <p>HARTLAND From \$234,900 810.629.2264</p> <p>GARRIAC</p> <p>SOUTH LYON From \$279,900 248.446.1439</p>
<p>WILLOWDALE</p> <p>AUGUSTA TWP. From \$249,900 734.461.9608</p> <p>PARKLANE</p> <p>WOODHAVEN From \$129,900 734.675.7550</p>	<p>WOODLAND RIDGE</p> <p>COMMERCE TWP. From \$259,900 248.684.1335</p>

Classified

0001-2450 Home & Service Guide

3000-3890 Real Estate For Sale

3890-3980 Commercial Industrial

4000-4980 Real Estate Rent/Lease

5000-5980 Employment Instruction Services

6000-6980 Announcements

7000-7780 Merchandise

7110-7130 Garage and Moving Sale

7800-7980 Animals Pets/Livestock

8000-8780 Automotive Recreational Vehicles

Place your ad toll free at 1-800-579-SELL



Walk-In Office Hours: Monday - Friday 8:30 am - 5:00 pm
Publication Day: SUNDAY PAPER.....5:00PM Friday
Deadline: THURSDAY PAPER.....5:30PM Tuesday



Private Party Customers Place your ad ONLINE 24/7 at www.hometownlife.com

The power of print and the internet

On-line at www.hometownlife.com • E-Mail Us: oeads@oe.homecomm.net

OBSERVER SALES OFFICE 36251 Schoolcraft, Livonia, MI 48150 • ECCENTRIC SALES OFFICE 805 East Maple, Birmingham, MI 48009

3000's Real Estate. Listings for 3000, 3009, 3040, 3043, 3045, 3050, 3055, 3060, 3070, 3080, 3090, 3100, 3110, 3115, 3120, 3130, 3135, 3140, 3145, 3150, 3155, 3160, 3170, 3180, 3190, 3200, 3210, 3220, 3230, 3234, 3235, 3236, 3238, 3240, 3250, 3260, 3265, 3270, 3280, 3290, 3300, 3310, 3315, 3318, 3320, 3330, 3340, 3345, 3350, 3360, 3370, 3380, 3390, 3400.

Open Houses 3030. Plymouth OPEN SUNDAY 14 14254 Shadywood N of Wilcox & W of Haggerty Very sharp & updated! 3 bdrm 2 baths living room dining room family room w/gas fireplace Hardwood floors clean & neutral New kitchen bath windows roof & more! Lake Po rite sub See it on Sunday! \$239 900 (SHA54) Call Lynn DeJohn (734) 451-5400

Birmingham 3050 Woodward Place The festive offered a a p est gous B mingham address convenient to shopping dining out a events entertainment & m t less othe exc'ng chooes to add to their qua ty of life Woodwa d Place and plan a amenit es offe a pr vate scen c meande ring fast flow ng r ver & a courtya d that calls to you to stop and take t me to sit to read play garden o ust be among large ha dwood trees n a pa k sett ng n the own backyard All the t me knowing out de the gates the last pace wor d awa ts them but for now wh a home n Woodward P ace t s the ve y own pr vate safe & beautif tile pece of pa adise shared only w th others who have chosen Woodwa d Place to ca home Visit our model homes today 1113 N Old Woodward Call for appt (248) 594-6680 Stating n the low 300's

Canton 3080 LOCATION LOCATION! 3 bdrm 1 5 bath home backing to nature preserve living room family room w/replace furnace a/c OS 2 car garage \$210 000 CENTURY 21 PREMIER (734) 453-4300 www.premersoldit.com JUST LISTED! NEED SOMETHING SPECIAL? 1/2 ACRE LOT 1 YEAR OLD Over 3500 sq ft upstas family room 3 car garage absolutely oaded w/apptas \$479 000 Call DANNY for deta s Group Ten Realtors (734) 454 0000

Garden City 3170 BUILT IN 2000 31495 Cambridge 1350 sq ft brck ranch 3 bdrm 2 bath 2 car attached garage \$199 900 734 564 5535 Owner Financing Available 3 bdrm full basement large yard large garage appliances included Great for first time buyers or investors \$133 900 Realtors OK 810 231 3639 PRICED TO SELL! New construction 1800 sq ft 3 bdrm 2 1/2 bath 3 car attached Warren/Merriman \$219 900 734 564 5535 Hartland 3200 JUST LISTED! Immaculate 3 bedroom 2 1/2 bath 2 story home on peaceful 37 acre setting with pond! Home includes lovely kitchen with oak cabinets and all appliances formal dining area cozy family room with fireplace and doorwall to deck 2nd fireplace in living room Basement is plumbed for bath 2 car attached garage plus a 30 x 40 pole barn with 220 & cement floor Hartland Schools \$289 900

Livonia 3250 CAPE COD 17138 Stamwich N/6 Mile E/Merriman 3 Bdrm 1 5 bath full bsmt garage A most 1700 sq ft Updates roof windows kitchen furnace \$219 900 MICHELLE ASCIONE 248 939 7355 (sell) 248 348 3300 ext 150 Re/Max 100 LAND CONTRACT 3 bdrm ranch garage fresh y remod eed Fenced yard \$139 000 \$1000/mo 313 805 5309 JUST LISTED! LIVONIA Honey stop the car! Ove 2300 sq ft 4 bdrms 2 full baths Updated kitchen w/appl ances hardwood floor s Great locat on \$239 900 CATHY ZENI 734 718 5451 Century 21 Row 734 464 7111

Novi 3290 Just Reduced! Extremely well maintained 2400 sq ft 4 bdrm 2 5 bath home This house has many extras incl a finished basement 2 1/2 car garage Lots of potential for expansion MARY McLEOD RE/MAX Alliance 734 462 3600 248 477 2006 www.marymcleod.com Call to place your ad at 1-800-579-SELL(7355)

Plymouth 3347 This Craftsman Style Bungalow has been completely modernized while maintaining the integrity of the era Double lot close to town Full basement 2 1/2 car garage Lots of potential for expansion MARY McLEOD RE/MAX Alliance 734 462 3600 248 477 2006 www.marymcleod.com Redford 3350 JUST LISTED! HOT! HOT! HOT! Nicely updated 3 bdrm 1 5 bath brck Ranch w/open floor plan Sun room finished bsmt w/office & attached garage New oak cupboards newer carpet windows roof & more \$147 000 (LY243) CENTURY 21 TODAY (313) 538 2000 www.century21today.com RANCH 3 Bdrm New roof siding windows a/c \$85 900 734 709 5900

3900-3980 Commercial/Industrial. Listings for 3900, 3910, 3920, 3930, 3935.

Westland OPEN 12 4 1 4 1447 Betty W of Wayne N of Palmer Completely renovated 3 bdrm ranch attached garage oversized lot full bsmt Move in condition Immediate occupancy Agent (734) 260 5747 WESTLAND OPEN Sat 1-4 34353 JOHN HAUK ST This 2 bdrm ranch w/deck & hot tub Lots of updates! A must see!! \$94 900 HELP U SELL (734) 454 9535 WIXOM 846 Nature's Cove N of Maple E/off Beck Beautiful 2 bdrm 2 5 bath townhome w/ull finished walk out bsmt & attached garage \$184 900 ALSO FOR RENT call for details KAREN BROWN RE/Max 100 248 348 3000 ext 212

Birmingham 3060 BUILDERS CUSTOM Parade of Homes over 2100sq ft + finished lower level pristine home 1/2 acre lot backing to Huron Meadows Metro Park Brighton schools Too many extras to mention MUST SEE \$310 000 (810) 281 0872 REAL-ESTATE at it's best! Observer & Eccentric WARM AND INVITING! Updated 3 bedroom brick ranch with basement! Great location paved road natural gas and relatively low taxes Master bedroom has room for 1/2 bath f des red Motivated Seller wants you to call about this wonderful home! Brighton Schools \$164 900 ENGLAND REAL ESTATE 888 211 9560 or 810 632 7427 Canton 3080 JUST LISTED! BEAUTIFUL 3 bdrm 2 5 bath Colonial w/2 story hardwood entry hall & powder room Family room w/replace & French doors to lg deck Dining room w/bay window Nice kitchen w/all appliances Bsmt 2 car attached garage \$344 000 (GL453) CENTURY 21 TODAY (734) 462 9800 www.century21today.com

Dearborn 3110 MUST SEE! Large 5 bed rooms 1 1/2 baths new carpeting fresh paint new furnace finished basement kitchen appliances Immediate occupancy \$0 down \$116 900 248 420 3474 VERY MOTIVATED Gorgeous 3 bdrm bungalow for sale or rent Hardwood floors neutral decor finished bsmt marble & granite throughout A must see! \$174 900 or \$1200/mo (313) 712 6500 Farmington 3140 BRICK RANCH 3 Bedroom Finished Basement \$0 Down \$500 approximate move in cost 517 202 9294 Farmington Hills 3145 By Owner GREAT DEAL! 3 bdrm totally updated ranch new kitchen \$20 000 off original price Must see Great schools Quiet street \$184 000 Call Jeff 248 787 3807 IMMEDIATE OCCUPANCY 3 Bdrm 1 5 bath brck ranch Exc cond Hardwood large new kitchen w/ appliances New paint in/out Bsmt w/ washer dryer C/A 2 car w/ opener \$169 900 248 867 6963

Farmington Hills 3145 FULL OF PEACE & JOY! Peaceful 10 acre tree set ng surroundings this 2492 sq ft 1 1/2 story home! Home includes 3 bedrooms 3 5 baths brick fireplace and skylights in living room spacious kitchen Florida room off dining and full finished walkout lower level 3 car attached garage 60x54 horse barn 48x35 utility barn and more! Hartland Schools \$548 000 CHRISTMAS SHOPPING? This appealing 3 bedroom ranch on pretty 2 84 acre setting would be perfect Great location on paved road with natural gas This spacious 2438 sq ft home includes Great room family room large mud room full finished basement fenced yard nice kitchen with eating area 2 car attached garage and more! Hartland Schools \$319 900 A HOME FOR ALL SEASONS! Peaceful 2 38 acre setting surrounds this lovely 3 bedroom 2 5 bath home on paved private road Home features family room with striking full wall brick fireplace and doorwall to 10x15 screened porch attractive white kitchen large 18x14 walk-in closet off master bedroom walkout basement large deck for relaxing 2 car attached garage plus 4 car detached garage and 10x12 potting shed! Hartland Schools \$310 000 ENGLAND REAL ESTATE 888 211-9560 or 810 632 7427 Howell 3230 IMMEDIATE OCCUPANCY 3200 sq ft 4 br 3 5 bath walkout 4 5 acres 64x52x14 heated out building \$410 000 (517) 548 5229

Northville 3280 Move before Christmas! Newly updated home w/open floor plan great locat on close to town oversized 2 1/2 car garage & more Only \$214 900 Fantastic 4 Bdrm 2 1/2 bath colonial centrally located in sub has extras galore & 3 car garage Now \$549 900 MARY McLEOD RE/MAX Alliance 734 462 3600 248 477 2006 www.marymcleod.com

Plymouth 3347 FOR SALE BY OWNER PLYMOUTH TWP 4 Bdrm colonial \$269 900 By appt 734 254 0611 By Owner OLD VILLAGE Craftsman Style raised ranch 2 bdrm 1 bath Hardwood Updated mechanicals Large covered porch Bsmt 2 car garage Private brck paver patio \$184 900 Call For Appt 734 306 5791

Rochester 3360 OAKLAND TWP Gorgeous 3200 sq ft 4 bdrm 3 5 bath colonial 3 fireplaces 1350 sq ft finished walk out Premium wooded lot Motivated sellers! \$535 000 586 243 3224 West Bloomfield 3440 (NORTHWEST) 3 4 br 3 bath Flexible layout 1900 sq ft Br 2 car garage With deck which views private wooded preserve Below Market \$299 900 Agents Protected Call 248 761 3467 no listings

3000-3980 Real Estate For Sale. Listings for 3000, 3009, 3040, 3043, 3045, 3050, 3055, 3060, 3070, 3080, 3090, 3100, 3110, 3115, 3120, 3130, 3135, 3140, 3145, 3150, 3155, 3160, 3170, 3180, 3190, 3200, 3210, 3220, 3230, 3234, 3235, 3236, 3238, 3240, 3250, 3260, 3265, 3270, 3280, 3290, 3300, 3310, 3315, 3318, 3320, 3330, 3340, 3345, 3350, 3360, 3370, 3380, 3390, 3400.

Open Houses 3030 DEARBORN HEIGHTS 25716 Cherry Hill 3 900sq ft new construction Open 7 days a week NORTHVILLE Colonial for sale Open Sun 2822 sq ft walkout wooded lot Call or visit for schedule 859 691 8108 www.sherwoodin.com Plymouth Open Sun 1-4 14146 B Drive N/N Territorial W off Ridge Very nice mobile home 2 bdrm 1 1/2 bath Completely updated \$16 500 Make offer! Ask about 3 free months lot rent Could be moved on property (586) 489 8474 CLASSIFIEDS WORK! 1-800-579-7355 ROCHESTER HILLS Open Sat Dec 3 1 3 BE HOME BY THE HOLIDAYS! \$25 Grocery Card Drawing! 3 Bdrm 1 5 bath 2 car garage New carpet & paint \$224 777 Move in condition 211 Dressler (S of Avon & E of Livonia) North Star Realty Inc 248 765 4422

Beverly Hills 3049 JUST LISTED! BEVERLY HILLS BIRMINGHAM SCHOOLS On nearly an acre spacious 2 250 sq ft 4 bdrm 3 full bath brck ranch w/2 car side entry garage Living room w/gas fireplace Huge kitchen w/gathering area has new cabinetry stainless steel appliances & hardwood floor Possible in law or au pair suite Circle drive \$274 900 (TH206) CENTURY 21 TODAY (248) 647 8888 www.century21today.com It's All About Results Observer & Eccentric 1-800 579 SELL

Farmington Hills 3145 By Owner CHARMING 1923 BUNGALOW 1300 sq ft 3 bdrm 2 new full baths New kitchen roof windows Natural fireplace copper pump Walk to downtown Ferndale \$176k 248 541 4508 Ferndale 3155 By Owner BEAUTIFUL COLONIAL 3 bdrm 1 5 bath 43608 Ger Drive (Canton School) Immaculate interior spacious kitchen finished bsmt C/A lg deck w/ fenced yard Naar sports field park Asking \$215 000 Call 616 780 9616 or 800 692 2413 x 301 for more info nation and \$0 down financing options Land contract possible

Ferndale 3155 By Owner CHARMING 1923 BUNGALOW 1300 sq ft 3 bdrm 2 new full baths New kitchen roof windows Natural fireplace copper pump Walk to downtown Ferndale \$176k 248 541 4508

Howell 3230 IMMEDIATE OCCUPANCY 3200 sq ft 4 br 3 5 bath walkout 4 5 acres 64x52x14 heated out building \$410 000 (517) 548 5229

Fair Housing Your Right, Our Business. As members of the NATIONAL ASSOCIATION OF REALTORS®, the METROPOLITAN CONSOLIDATED ASSOCIATION OF REALTORS® is proud of our contributions in support of the Fair Housing Act and other Fair Housing Compliance programs. Our REALTORS® have led the housing industry in promoting fair housing and are committed to opening the door of your choice. FAIR HOUSING OPENS DOORS REALTORS ARE THE KEY

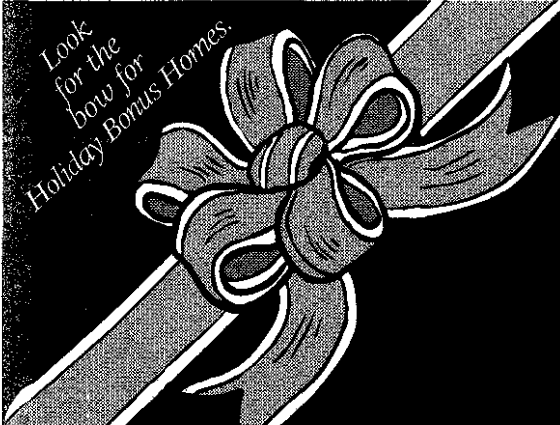

Holiday Bonus Homes



Receive \$2000-\$5000 when you purchase a participating property by January 31, 2006. Go to HolidayBonusHomes.com for complete details.

The Real Estate One family of Companies: Real Estate One • Max Brock Realtors • Johnstone & Johnstone • Capital Title Insurance Agency • Insurance One Agency • John Adams Mortgage Company • Relocation America

- | | | | |
|--|--|---|---|
| <p>BLOOMFIELD TWP 248-348-6430
 RAMBLING RANCH ON 3/4 ACRE CUL. DE SAC Low maintenance 3 BR freshly painted inside new windows hrdwd flrs under carpet full fin bsmt c/a & all appl 2 car side entry gar w/storage 349 6200 (25131804) \$389 000</p> <p>BROWNSTOWN TWP 734-455-7000
 FORMER BUILDERS MODEL I Dream Home Quality on Premium Lot awaiting the most discerning buyer Custom evaluation loaded with upgrades - 4BR 2 5BA 3 car garage (25129230) \$296 900</p> <p>CANTON 734-455-7000
 WOODS AT CHERRY HILL VILLAGE 14 BR/ 3 1BA Col Spec nestled in protected woodlands 3 home styles available to build Holiday Bonus Upgrade of \$10 000 to buyer if PA signed by 1/31/06 (24158216) \$499 900</p> <p>CANTON 734-455-7000
 ONE OF A KIND ENERGY EFFICIENT HOME 1 New const Foyer w/cir staircase hrdwd fl in foyer kit & half BA Granite tops in kit isl and lav Rear staircase Mstr ste w/wash BA Ready to move in (25159198) \$499 900</p> <p>CANTON 734-455-7000
 POPULAR GLENGARRY SUB 3-car gar 1st fl Indry Lg deck 2-story foyer Kit w/oak cabs isl hrdwd flrs FR w/gas FP LR w/bay window Mstr ste w/cath ceiling mstr BA w/shower Wood wndws (25111125) \$330 000</p> <p>CANTON 734-455-7000
 RANCH CONDO ON 26TH FAIRWAY! Instantly appealing Upgrades T/O 2BR 2BA den lg GR 2-way FP Deck Beautifully decorated (25163038) \$310 000</p> <p>CANTON 248-348-6430
 ATTRACTIVE AND INVITING COLONIAL Meticulously cared for on cul de sac charming kit & brkfst area LR w/vaulted ceiling cozy DR comfortable FR wonderful fin bsmt 2 brck paver patios 349 6200 (25151186) \$300 000</p> <p>CANTON 734-455-7000
 FAMILY-FRIENDLY EXECUTIVE COLONIAL! Beautiful 4 lg bedrooms including a sumptuous master suite 2 5 BAs new carpet freshly painted newer built (25104771) \$294 000</p> <p>CANTON 734-455-7000
 PRETTY AS A PICTURE! 4BR Colonial with Plymouth/Canton schools Private backyard surrounded by trees Great deck for entertaining Well decorated & ready to move in (25149937) \$269 957</p> <p>CANTON 734-455-7000
 CLOSEST THING TO CAREFREE LIVING! Best lot in complex backing to woods Hardwood thruout Mstr on main fl Corian counters Jetted tub 3BR/2 5BA (25165192) \$264 900</p> <p>CANTON 734-591-9200
 New construction 2 Fir Plns to choose from Prices starting at 219 900 Loc SE Corner of Joy & Sheldon (COLUMBIA) \$219 900</p> <p>CANTON 734-455-7000
 A DREAM COME TRUE! 3BR Colonial w/ updated kitchen Beautiful maple cabs & hrdwd flrs Major updates complete and ready for you to move in (25162144) \$214 900</p> <p>CANTON 734-455-7000
 MOVE RIGHT IN! A wonderful 2BR 2 5 Bath condo with full basement Everything is done One of the best locations in the complex Hurry and check out the view in back (25131534) \$199 000</p> <p>CANTON 734-591-9200
 2 bedrooms 2 5 bath dramatic staircase in GR Cath ceiling w/fan & FP Mstr BR has 2 WIC Bright kit has new fir & drwall to patio appls stay 1st fl Indry 2 car gar & bsmt (25009266) \$175 900</p> <p>CANTON 734-326-2000
 WOW! 1 440 SQ FT OF PURE LUXURY w/these wonderful upgrades appliance package maple raised paneled cabinets brushed chrome hardware rollout shelves 2 Big BR & 2BA located near the Pool (25149374) \$162 900</p> <p>CANTON 248-348-6430
 CANTON FORD & SHELDON BEAUTIFUL 3 BR Condo w/ 1 1/2 BA Close to shopping & freeways & fin bsmt have new carpet Eat in kit w/new maple cab & all appl Ceramic tile in foyer & bathrooms 349-6200 (25130248) \$147 500</p> <p>COMMERCE TWP 248-348-6430
 BUILDERS MODEL 3300 sq ft All granite t/o 1st fl mstr GR custom kit Fully landscaped & cedar deck Beautiful! Nothing spared 349 6200 (25167921) \$600 000</p> <p>COMMERCE TWP 248-348-6430
 CUSTOM BUILT HOME IN TWIN SUN LAKE Home features 1st & 2nd fl mstr suites Sun bathed GR w/sconing ceiling opens to lg DR Backs to commons pond & play area Community offers lake access 349 6200 (25129270) \$339 900</p> <p>DEARBORN 248-348-6430
 SUPER SHARP! 5 BR 2 5 BA HOME Totally remodeled from the inside out in 2004 New kit baths win doors roof siding plumbing hrdwd flrs 349-6200 (25136031) \$170 000</p> <p>DEARBORN HEIGHTS 734-591-9200
 Huge new eat in kitchen with tons of storage in the new oak cabinets Great open flr plan perfect for entertaining large groups of family & friends Newer wndws roof turn and more (25162385) \$144 900</p> <p>DETROIT 734-455-7000
 A VERY UNIQUE 3BR BUNGALOW! Lg front porch Back deck w/hot tub Huge Mstr BR w/2 lg closets Spacious kit w/dining area FR w/drvl leading to deck Roof is 4 yrs old Newer wndws on main lvl (25133232) \$132 000</p> <p>DETROIT 734-326-2000
 TERRIFIC INVESTMENT Is this 3/3 Flat Lower unit w/ Oak Cabinetry & Moldings Clean & Well Maintained with a Basement Upper Rented Two Boilers and two Electrical Meters Garage (H644) 25066364 \$79 000</p> | <p>FARMINGTON 248-348-6430
 ATTRACTIVE COLONIAL ON A PRIVATE WOODED LOT 4 BR 2 full & 2 half BA huge kit w/panoramic view of serene back yard 6 panel doors t/o fin LL w/frplc bath wet bar home warranty 349 6200 (25148796) \$366 500</p> <p>FARMINGTON HILLS 734-591-9200
 Do some of your own updating and reap the rewards 3 BR brck ranch in ever popular Kendalwood w/large lots Liv Rm w/FP fam rm full bsmt 2 cat att gar Good condition & some updates (25153478) \$219 900</p> <p>GARDEN CITY 734-326-2000
 WOW \$179 900 FOR ALMOST 2000 SQ FT! No I dont have a Basement I have SQ FT! 2 yes I said 2 Master Stes 1 EL (Perfect for Mom in law 2 addl BR 2 BA GR w/FP 1st FL Laundry Fence for Fido (C570) 25148918 \$169 900</p> <p>GARDEN CITY 734-455-7000
 SUPER HOME! You ll love this beautiful brck ranch Fin bsmt 2 full baths Newer roof A/C deck copper plumbing kit carpet circuit bck HWH too many to list Call today! (25139275) \$159 900</p> <p>GARDEN CITY 734-326-2000
 ROOMY YET COMPACT Is this Unique 3 Bedroom Tr Level in Garden City with 1 1/2 Baths Refinished Hardwood Floors Family Room LL Walkout C/A and 2 Car Garage (D325) 25142267 \$154 900</p> <p>GARDEN CITY 734-326-2000
 COUNTRY ATMOSPHERE Defines this Aluminum Bungalow on a Huge 92x135 Lot with Family Room Ceramic Tile Bath Hardwood Floors Newer Roof & Garage All for only \$144 900 (H288) PC 220992 25135991 \$144 900</p> <p>GARDEN CITY 734-455-7000
 ALL BRICK BUNGALOW ON A LARGE CORNER LOT New tear-off roof w/newer furnace and windows 2BR upstairs and 1 main Remodeled bath w/large tub (25160337) \$138 900</p> <p>GREEN OAK 248-348-6430
 NEW CONSTRUCTION RANCH W/LAKE ACCESS Almost 2000 sqft of fabulous 1st flr living full brck exterior Awesome island kitchen Huge master suite All sports Whitmore Lake priviledges 349 6200 (25129235) \$349 500</p> <p>HAZEL PARK 734-591-9200
 If you want to move into a home & relax this 3 BR ranch is for you Wonderful updates thruout Roof kit plbg elec Beautifully finished bsmt w/1/2 BA special patio effects in backyard & more (25102517) \$129 900</p> <p>INKSTER 734-326-2000
 PERFECT STARTER HOME Cozy & Comfortable 2 BR Brck Ranch has an Open Floor Plan Fireplace lg deck & Hot Tub off the Family Rm Basement Partially Fin w/ Bar All Appliances inc (A515) 25115815 \$93 000</p> <p>LATHRUP VILLAGE 248-348-6430
 CLEAN AND READY IN LATHRUP VILLAGE Move right in to this awesome ranch! 3 bedrooms finished basement hardwood floors and 2 car garage 349 6200 (25148771) \$179 900</p> <p>LIVONIA 734-591-9200
 Location quality value & charm! Attractive 2400 sqft brk colonial 4 BR 2 5 BA FR w/FP 1st flr Indry bsmt & 2 car att gar New roof & doors All appls stay (25076879) \$314 900</p> <p>LIVONIA 734-591-9200
 Well Maintained HBH 3 bedroom 2 bath ranch located in Green Bner Estates Sub 5 acre lot with mature trees Home also has a Florida Rm and a 2 5 car garage (25131287) \$299 900</p> <p>LIVONIA 734-591-9200
 Hurry to this beautiful 4BR 2 5 bath colonial in Francavilla Sub! Fabulous curb appeal fam rm w/FP open to kit Bsmt 2 car att gar Clean great 500 sq ft deck Lv Stevenson HS (25080889) \$289 900</p> <p>LIVONIA 734-455-7000
 WELCOME HOME! Move in! Updates thruout Lg kit w/conan counters 2 1/2 car att gar Part fin basement Mstr BR/BA Wallside windows roof on house and garage new in 2001 (25128638) \$217 000</p> <p>LIVONIA 734-591-9200
 Location quality value & charm 1200 sqft brk ranch completely updated in 05 Updts incl all new kit w/cabs cer tile flr & cntr tops New appls All new BA Refin hrdwd flrs bsmt & 2 car gar (25131463) \$189 900</p> <p>LIVONIA 734-326-2000
 AVAILABLE TODAY Is this 3 bedroom Vinyl Bungalow on a Half Acre lot in Livonia W/ Family Room with Fireplace 1 1/2 baths redecorated Kitchen and 2 Car Garage (G155) 25071070 \$189 900</p> <p>LIVONIA 734-591-9200
 Livonia! All You Are Looking For! 3 BR brck ranch w/fin rec rm Feat newer Weather Guard Wndws w/marble sills & DR wall leading to deck & fenced yrd Newer furn & C/A oversized gar dr w/opener (25063982) \$179 900</p> <p>LIVONIA 734-326-2000
 COME SEE WHAT'S NEW In this 3 BR brck & vinyl Livonia ranch w/full fin bsmt w/bar 2 full baths Central air newer windows & 2 1/2 car garage W/opener you won't be disappointed (H906) PC 220892 25092598 \$169 900</p> <p>LIVONIA 734-591-9200
 3 BR 2 BA brck ranch w/ finished basement Neutral t/o FR w/ fireplace garage fenced yard fire pit (25136766) \$167 900</p> <p>LIVONIA 734-591-9200
 Great! Updated 3 bedroom ranch with Livonia Schools! 2 car garage Fireplace new roof windows furnace kitchen bath ect (C28546) 25135123 \$154 900</p> <p>LIVONIA 734-591-9200
 3 BR 2 BA brck ranch in excellent location Fenced yard large deck detached garage and all mechanicals updated (25166213) \$149 900</p> <p>LIVONIA 734-591-9200
 All brck bungalow Livonia with 1467 sq ft 2 full BA newer roof electrical HWH & more 2 5 car garage w/220 heat built in air lines & a second story for finishing or storage (25149222) \$149 900</p> | <p>LIVONIA 734-591-9200
 Beautiful updated private entry 1st flr 2 BR 2 Bath 971 sq ft condo Scenic views of the private nature pond All appls stay (25120925) \$119 000</p> <p>NORTHVILLE 248-348-6430
 STATELY COLONIAL ON 0 4 ACRES Kit has island cherry cabs granite cntrs & high-end appliances Lib w/bev/gls drs & custom cherry bk cases LL has custom wet-bar 349 6200 (25137759) \$1 190 000</p> <p>NORTHVILLE 248-348-6430
 RAVINES OF NORTHVILLE EXECUTIVE HOME 4 bdrm 3 5 baths Gourmet kit w/granite island FR w/vaulted ceiling Spacious mstr suite Jack n-Jill bath Extensive use of crown molding & wainscoting 349-6200 (25160133) \$599 900</p> <p>NORTHVILLE 248-348-6430
 OWN A LITTLE PIECE OF HEAVEN 3 5 acres Beautiful prop Secluded yet close to everything Custom bit ranch Tons of upgrades Granite kit amazing LL w/2020 add l sq ft 349 6200 (25166299) \$570 000</p> <p>NORTHVILLE 248-348-6430
 CLOSE TO TOWN UPDATED 3 BR RANCH Custom kit refinished hrdwd flrs fresh paint in & out new carpet DR w/ bay window GR w/fp Quiet cul de sac location close to parklike commons 349-6200 (25146840) \$349 900</p> <p>NORTHVILLE 248-348-6430
 HISTORIC NORTHVILLE Walk to quaint downtown Northville Charming cape cod Two frplcs DR w/bay window Updated kit & baths Mechanics dream garage Lovely lot w/ many perennials 349-6200 (25068900) \$314 900</p> <p>NORTHVILLE 248-349-6200
 OPEN FLOOR PLAN IN THIS CHARMING RANCH Beautifully maintained updated thruout hrdwd flrs in kit DR & FR Super LL w/daylight windows Country feeling walk downtown A great condo alternative 348 6430 (25034152) \$299 999</p> <p>NORTHVILLE 248-348-6430
 BEAUTIFUL CONDO Spacious 3 bdrm 2 5 ba unit with a fin bsmt Updated kit furnace A/C H2O wndws Deck frplc newer carpet Everything you want is in this one 349-6200 (25128841) \$199 900</p> <p>NORTHVILLE 734-591-9200
 Desirable 2 BR ranch condo features prof finished bsmt with 2nd flr bath private patio with deck many updates Highland Lakes A great place to live (25150365) \$149 900</p> <p>NOVI 248-348-6430
 COZY LITTLE WELL MAINTAINED HOME Loving pride of ownership reflected t/o this fine ranch home in wonderful Whispering Meadows subdivision Located back in the treed section Lg GR w/frpl 349 6200 (25072285) \$221 900</p> <p>NOVI 248-348-6430
 UPDATED HOME ON GREAT LOT Wonderful home priv yard backing to stream nice oak kit 3BR 2 full BA lg laundry new drive covered patio new hi E furnace well cared for home 349-6200 (25096192) \$200 000</p> <p>NOVI 248-348-6430
 LAKE ACCESS BIKE TRAILS & MUCH MORE Enjoy this 2 bdrm 2 bath Novi condo overlooking Walled Lake Buyer must be 50+ upper unit near elevator in bldg All appl included Assigned carport 349-6200 (25093259) \$127 900</p> <p>PLYMOUTH 734-591-9200
 Built in 2001 3 BR 2 5 BA cape cod delivers exclusive upgrades incl maple kit cabs extensive HDWD flrs 1st flr Mstr w/bath that offers jetted tub & sep shower volume clngs in GR & FP (W51013) (25130836) \$424 900</p> <p>PLYMOUTH 248-348-6430
 Nature lovers delight 2 2 acres w/Plymouth Canton schools Tons of features including new oak kit new roof vinyl wndws hrdwd flrs Spacious room sizes w/4 brdms & 2 full baths 349-6200 (25141161) \$299 950</p> <p>PLYMOUTH 734-455-7000
 SPACIOUS COLONIAL IN OLD ORCHARDS SUB 3BR 1 5BA COL Easy access to 1 275 & downtown Ply New roof White bay cabs Conan sink Cozy FR w/FP bookshelves on sides of brck hearth Dbl doors into Mstr (25139267) \$223 900</p> <p>PLYMOUTH 734-455-7000
 BEAUTIFULLY MAINTAINED AND UPDATED Spacious 3BR home in affordable Twin Arbors with outstanding 12 x 11 sunroom w/Pella windows and doorwall (25134481) \$219 900</p> <p>PLYMOUTH 734-455-7000
 WALK TO DOWNTOWN PLYMOUTH 2BR upper ranch condo w/bay window vaulted ceiling sky lights oak cabs Mstr BR has 2 WICS Andersen windows new furn in Aug 05 Seller motivated (25139282) \$129 900</p> <p>PONTIAC 248-348-6430
 CHARMING BRICK RANCH ON PEACEFUL STREET Enjoy the warmth of plaster walls and cove ceilings in beautiful shades of beige Hrdwd flrs t/o Newer ceramic flr in kit Full bsmt for storage 349 6200 (25125884) \$134 900</p> <p>REDFORD 734-591-9200
 3 BR 2 5 BA 2200+ finished sft Hardwood FR w/ fireplace Master w/full bath HUGE Florida room Treed lot great value! (25154185) 174 900</p> <p>REDFORD 734-591-9200
 Lots of home for the money! 3 BR brck ranch 2 5 BAs full basement and enclosed breezeway to attached garage Put this one on your list to see (25133401) \$158 900</p> <p>REDFORD 734-591-9200
 3 BR 1 5 bath ranch finished basement with bar for entertaining family & friends Bath and a half on the main floor All appliances stay (25158479) \$144 900</p> <p>REDFORD 734-591-9200
 Wonderful brck home located in desirable neighborhood within walking distance of parks and schools 3BR full bsmt side entry gar lots of nice updates doorwall walks out to deck (25101125) \$129 900</p> <p>REDFORD 734-591-9200
 This wonderful home has an awesome backyard beautiful landscaping & big ticket updates like furn & wndws Lrg eat in kit has plenty of room for table & lg wndw overlooking backyard (25124629) \$116 900</p> | <p>REDFORD 734-591-9200
 Affordable updated ranch All new kit w/cer fir updated BA w/marble flr & pedestal sink Refin hrdwd flrs all new paint & lgt fixtures Clarenceville Schls Appls tool (25157771) \$104 900</p> <p>ROCHESTER 248-348-6430
 BROOKLYN PIZZA/ICE CREAM BUSINESS Downtown Rochester Wood fired oven homemade ice cream gelato Italian ice 1800 sq ft seats over 40 Includes equipment & inventory 349-6200 (25084901) \$100 000</p> <p>ROMULUS 734-455-7000
 AFFORDABLE GOLF COURSE LIVING! Sharp and stylish contemporary cape cod on the golf course! 3BR fin bsmt w/4th BR 1st fl mstr ste open and airy GR Tons of upgrades 40 deck (HBH) (25120465) \$224 900</p> <p>SOUTH LYON 248-348-6430
 VERY SPECIAL HOME PRETTY AS A PICTURE! Attractive remodeled Col stone frplc in DR charming kit lovely LR oak flrs crown molding 3 brdms 2 baths covered front porch side porch stone patio 349 6200 (25164144) \$219 900</p> <p>SOUTHFIELD 248-348-6430
 SPACIOUS DETACHED RANCH CONDO AMUST SEE Wood entry w/pantry closet White kitchen w/wood flrs eat-in area Lg laundry rm w/lots of cabinets & desk area 2 assigned parking spaces in front 349 6200 (25125546) \$139 900</p> <p>SUPERIOR TWP 248-348-6430
 BETTER THAN NEW Move in ready Landscape deck sprinklers C/A wndw treatments all done Brook model w/add sq ft upgrade Open flr plan neutral lg yard commons playgrd 349 6200 (25126363) \$215 000</p> <p>WARREN 248-348-6430
 GREAT STARTER CLOSE TO GM TECH CENTER LR carpet door & wndws in 04 vault cel w/skylites in mstr bdrm & DR lg Fla rm in front remodeled kitchen w/newer oak cabs freshly painted 349-6200 (25156408) \$100 000</p> <p>WATERFORD 734-591-9200
 1947 sq ft 3 bedrooms 2 5 baths Mstr suite w/bath & WIC kitchen w/oak cabs walk out bsmt backs to woods lake access to Pleasant Lake deck and paver patio (C617) \$249 900</p> <p>WAYNE 734-326-2000
 BEAUTIFUL FAMILY FRIENDLY HOME! Lighted Deck Hardwood Foyer & Hallway Island Kit Mstr w/Bath FP Basement ready for Drywall framing complete plumbed for full bath Immed occupancy (B500) 25149281 \$189 900</p> <p>WAYNE 734-326-2000
 COUNTRY IN THE CITY 3 BR Ranch 1 5 car gar & 16x16 Shed Newer Wndws & Rf Mud Rm MBR w/WIC 257 Lot PC 221012 (25127909) \$103 000</p> <p>WESTLAND 734-591-9200
 Well maintained 5 BR 3 full bath home in Westland Mother in law apartment upstairs w/2BR & 1 BA Lg home offers newer roof newer wndws hrdwd flrs lrg eat in kit part fin bsmt (25119773) \$204 900</p> <p>WESTLAND 734-591-9200
 Newer Construction Condo w/loads of updates Fully fin basement w/ceiling Egress wndw Home features gas fireplace deck ceramic tile hrdwd flrs stainless steel appliances and much more (25074971) \$199 900</p> <p>WESTLAND 248-348-6430
 Very Nice! Very neutral! Very newly new! 3 BR 2 5 BA colonial w/professionally fin bsmt Built in 2001 home is bright neutral & in move-in condition Newer sub/wsidewalks & close to everything 349-6200 (25156459) \$195 000</p> <p>WESTLAND 734-326-2000
 IDEAL OPPORTUNITY In this 2 bedroom 1 1/2 bath 2 story condo in Westland Full finished basement 2 car attached garage first floor laundry C/A (D702) PC 220082 (25142567) \$168 000</p> <p>WESTLAND 734-591-9200
 Charming 3BR brck ranch with full bsmt Home features family room with fireplace deep lot 2 car garage hardwood floors newer roof glass blk windows and much more (25104228) \$149 900</p> <p>WESTLAND 734-326-2000
 BEGIN HERE AND LOOK NO MORE! Enjoy this beautiful 3 BR 2 BA home Everything is just like new Independence begins by owning your own home This home is perfect for the 1st time buyer (G323) (25124963) \$145 900</p> <p>WESTLAND 734-326-2000
 PERFECTLY PERFECT! No stone unturned Beautiful hardwood floors brand new kitchen updated bath finished basement new roof new windows Squeaky clean! (F318) (25149851) \$139 900</p> <p>WESTLAND 734-326-2000
 ABSOLUTELY FABULOUS OPEN FLOOR PLAN! 2 Walk-In Closets in a huge Master BR formal DR lg eat in kit C/A sharp landscaping 2 car garage deck Couldn't be any cleaner Move in condition (B143) (25165648) \$139 900</p> <p>WESTLAND 734-326-2000
 GREAT RETURN FOR A SMALL INVESTMENT! This duplex is in great shape! Newer roof & plumbing vinyl siding Both sides are rented This one won't last long Hurry! (A316) (25123915) \$109 900</p> <p>WESTLAND 734-326-2000
 GREAT RETURN ON A SMALL INVESTMENT! This duplex is in great shape! New roof newer furnace in 1 Unit updated kitchen & bath in the other Both units are rented (A317) (25123925) \$99 900</p> <p>WESTLAND 734-326-2000
 SHARP DUTCH COLONIAL Great curb appeal on this 3 BR 1081 Sq Ft Colonial w/fin bsmt Needs minor TLC Lots of bang for the buck w/newer furnace windows & siding Big front porch! (C232) (25078766) \$89 900</p> <p>WESTLAND 734-326-2000
 BUDGET WISE? Then you will appreciate this 2 bedroom brck ranch with full basement in Westland Newer carpeting and windows & remodeled kitchen and bath (A259) (25060976) \$84 900</p> |
|--|--|---|---|

Observer & Eccentric



Real Estate

HOMETOWNlife.com

<p>Homes 3000</p> <p>POLICY All advertising published in the Observer and Eccentric Newspapers is subject to the conditions stated in the applicable rate card. Copies are available from the advertising department. Observer and Eccentric Newspapers reserve the right not to accept an advertiser's order. Observer and Eccentric Newspapers sales representatives have no authority to bind this newspaper or only publication of an advertisement shall constitute final acceptance of the advertiser's order. When more than one insertion of the same advertisement is ordered, no credit will be given unless notice of typographical or other errors is given in time for correction before the second insertion. Not responsible for omissions. Publisher's Notice: All real estate advertising in this newspaper is subject to the Federal Fair Housing Act of 1968, which states that it is illegal to advertise any preference, limitation or discrimination. This newspaper will not accept any advertising for real estate which is in violation of the law. Our readers are hereby informed that all dwellings advertised in this newspaper are available on an equal housing opportunity basis. (FR Doc 724983 3 31 72) Classified ads may be placed according to the deadlines. Advertisers are responsible for reading their ads the first time it appears and reporting any errors immediately. The Observer and Eccentric Newspapers will not issue credit for errors in ads after the FIRST CORRECTED INSERTION. Equal Housing Opportunity Statement: We are pledged to the letter and spirit of U.S. policy for the achievement of equal housing opportunity throughout the nation. We encourage and support an affirmative advertising and marketing program in which there are no barriers to obtaining housing because of race, color, religion, national origin, Equal Housing Opportunity slogan. Equal Housing Opportunity. Table III illustration of Publisher's Notice.</p>	<p>Westland 3445</p> <p>JUST LISTED! \$124,900 GETS ALL THIS! 3 spacious bdrms garage 1st floor laundry bsmt covered patio C/A newer roof windows carpet driveway Fresh & clean! Call DANNY for details Group Ten Realtors (734) 454 0000</p> <p>JUST LISTED! BEAUTIFULLY MAINTAINED Brick Ranch 3 bdrm 1.5 bath updated kitchen wood floors & walls side windows Bsmt w/bar All appliances stay New roof on house & garage \$159,900 (GA825)</p> <p>BRING ALL OFFERS! 3 bedroom ranch living room dining room 3 season Florida room never furnace & roof basement \$141,000 CENTURY 21 PREMIER (734) 453-4300 www.premiersold.com</p> <p>BY OWNER Meticulously maintained home is ready for immediate occup. Most of the expensive updates are done. 3 bdrm 1 bath fin bath 1020 sq ft \$162,500. Additional info call 734 425 8003</p> <p>SHARP & CLEAN 3 bdrm brick ranch finished bsmt with c/o newly remodeled oak kitchen w/ built in appliances 3558 Florane W of Wayne off Avondale Open Sat Sun 1-4pm \$157,900 734 812 3465</p> <p>WESTLAND Rent to own \$900/mo 3 bdrm 1 bath 1 car attached Brand new kitchen & bath 246 910 1077</p>	<p>Lapeer County 3515</p> <p>CHRISTMAS IN METAMORA! Magnificent stone & brick country French home on 10 acres 4 bedrooms 6 baths vaulted ceilings great room den 1st floor master granite hardwood floors finished walk out 4 fireplaces new carriage house trout pond private gated assoc Additional 10 acres avail \$1,395,000. Can't be duplicated for this price! Much more Snyder Kinney Bennett & Keating 248 505 7770</p> <p>Livingston County 3520</p> <p>SEARCH THOUSANDS of homes online @ www.livingstonmls.com 810 599 6471</p> <p>Wayne County 3570</p> <p>NEEDS TLC! 3 Bedroom ranch w/garage. As is. Fixer upper w/lots of potential! \$59,900 (39D0)</p> <p>PACK YOUR BAGS! Move in ready! 2 bedroom Ranch. Many updates & upgrades! \$53,900 (351S)</p> <p>Century 21 Hartford South 734 464 6400</p> <p>Real Estate Auction 3620</p> <p>Grosse Isle, MI AUCTION 12-3-05</p> <p>Personal property 10am Real Estate 2pm 7 96 Acre 20521 Meridian Road 2365 sq ft ranch Open 11 27 05 1 3pm 11 30 05 6 7 30pm Bid Your Price Call for your FREE Property Info Packet (517) 678 9800 shendanauctionservice.com Harley Davidson Soft Tail Pontiac F rebird Firearms Commerce at Equip including End Loader Old Pocket Watches Collectibles Meat Processing Generator Tools & much more Visit website www.auctions.com Or call (248) 473 1547 SHERIDAN REALTY & AUCTION CO</p> <p>CLASSIFIEDS WORK! 1-800-579-7355</p>	<p>Real Estate Services 3640</p> <p>FORECLOSED HOMES Residential commercial & land Low % rates \$0 down 1st time buyers or investors 1 800 949 8020</p> <p>Condos 3720</p> <p>BETTER THAN NEW! 2 bdrm end unit condo backs to pond Tons of upgrades great room eat in kitchen 1st floor master 2nd bdrm or loft all appliances bsmt with egress window garage CENTURY 21 PREMIER (734) 453-4300 www.premiersold.com</p> <p>BLOOMFIELD HILLS Secluded 3 bdrm condo Cranbrook area Remodeled \$360,000 248 752 0342</p> <p>Blomfield Hills City of Gorgeous condo 2 bdrm 2 bath den cin g room living room kitchen w/a nook 2 car attached garage model condition Overlooking park like setting 1835 sq ft \$349,000 or lease Michael @586 929 6055 Killarney Realty 1280 US 12</p> <p>BLOOMFIELD HILLS By owner better than new completely updated 3 bdrm 5 5 baths library atrium fin shed bsmt MUST SEE! \$549,900 (248) 433 1184</p> <p>It's no gamble</p> <p>when you advertise in The Observer & Eccentric Classifieds! 1-800-579-7355</p>	<p>Condos 3720</p> <p>JUST LISTED! FARMINGTON HILLS GATED COMMUNITY Spotless 1650 sq ft 2 bdrm 2.5 bath end unit brick ranch Condo w/ssid 1 000 sq ft in finished daylites bsmt Great room w/fireplace Master suite has private bath w/Jacuzzi & separate shower First floor laundry All appliances stay Vaulted ceilings throughout 2 car garage Tread park like setting \$325,000 (SA369)</p> <p>FARMINGTON HILLS Two bedroom condo with stunning view from every window Balcony faces trees and rver Freshly painted Kitchen includes appliances Assocat on fee includes water and heat Move in and enjoy! Century 21 Hartford North 734-525-9600</p> <p>GROSSE POINTE CONDO Walk to Village & Hospital 3 Bedrooms 2.5 Baths lots of upgrades Basement & attached garage 2 000 sq ft \$160 000/mo CMS (248) 549 0900</p> <p>LIVONIA 2 bdrm 1 1/2 bath full bsmt carport Spacious sharp 6 appliances heart of Livonia Many features! \$124,900 313 535 1183</p> <p>1999 BUILT 2 bdrm 1 1/2 bath ranch w/convenient location Deck attached garage all appliances Immediate occupancy Now \$169,900 MARY McLEOD RE/MAX Alliance 734 462 3600 248 477 2006 www.marymcleod.com</p> <p>JUST LISTED! LIVONIA Don't miss the 2 bdrm 2.5 bath w/basement & 2 car attached garage 1st floor laundry hardwood flooring skylight fireplace & so much more! \$250,000 Call Wally Justus Century 21 Row 734 464 7111</p>	<p>Condos 3720</p> <p>JUST LISTED! LIVONIA Gorgeous premium end unit Cape Cod style condo w/open floor plan Huge great room w/fireplace library gourmet designer kitchen & 1st floor laundry Bsmt 2 car attached garage \$329,000 (NE376)</p> <p>Century 21 CENTURY 21 TODAY (734) 462 9800 www.century21today.com</p> <p>JUST LISTED! LIVONIA New Construction 3 bdrm finished bsmt attached garage Super low assoc fee \$277,900 Karen Camilleri 734 502 8289 Century 21 Row 734 464 7111</p> <p>1995 BUILT 3 bdrm 2 bath detached ranch w/bsmt and 2 car attached garage Beautiful neutral decor cathedral ceilings open floor plan \$349,900 MARY McLEOD RE/MAX Alliance 734 462 3600 248 477 2006 www.marymcleod.com</p> <p>By Owner</p> <p>PLYMOUTH UPSCALE 2 bdrm ranch condo in beautiful down town Heated underground parking Move in immediately! \$239,900 734 416 8176</p> <p>It's all here!</p> <p>1-800-579-SELL www.hometownlife.com</p>	<p>Condos 3720</p> <p>JUST LISTED! SOUTHFIELD ONLY \$157,900 Well maintained & spacious 1520 sq ft 3 bdrm 2.5 bath townhouse Condo Living room w/fireplace & dining room have hardwood floors Updated kitchen w/breakfast area 2 doorways to patio/garden area Bsmt awaits finishing touches Carpet Pool in complex (FR250)</p> <p>Century 21 CENTURY 21 TODAY (248) 647 8888 www.century21today.com</p> <p>TROY 2 bdrm condo in Strathmoor complex New appliances in kitchen Hot tub \$163,900 248 752 0342</p> <p>WEST BLOOMFIELD 2 bdrm 2 bath totally updated w/beautiful view of pond & woods balcony garage \$150,000 249 921 6632</p> <p>JUST LISTED! WEST BLOOMFIELD ONLY \$167,900 Spacious 2 story Condo w/open floor plan high ceilings & skylites Living room w/fireplace Kitchen w/dining area bay window & appliances 2.5 baths Two bdrms including master suite w/walk in closet & bath Finished bsmt Brck paver patio Two car attached garage (GR706)</p> <p>Century 21 CENTURY 21 TODAY (248) 855 2000 www.century21today.com</p> <p>Sell it all with Observer & Eccentric 1-800-579-SELL</p> <p>Westland TWO YEARS NEW And ideally situated at the rear of complex this 2 bedroom 2 bath unit is neutral with vaulted ceilings deck attached garage and more \$157,500 MARY McLEOD RE/MAX Alliance 734 462 3600 248 477 2006 www.marymcleod.com</p>	<p>Condos 3720</p> <p>WESTLAND Woodland Creek Manor 7633 Manor Circle No 201 Central City Parkway/Warren 915 sq ft upper unit 2 bdrm 1 bath large walk in closet master bdrm in unit laundry New Laminite kitchen/dining room Floor Includes kitchen appliances \$93,500 Call for appt 248 982 5513</p> <p>Manufactured Homes 3740</p> <p>CANTON For sale in Holiday Park 734 453 0569 289 963 7677</p> <p>GREAT DEALS! SKYLINE HOME FOR THE HOLIDAYS! 3 Bed rooms 2 Baths All Appliances Separate Laundry Room With Washer & Dryer C.A. Shed 20' Covered Deck \$49,900</p> <p>VICTORIAN WELCOME HOME! 2 Bedrooms 2 Ba's in A1 App almost C.A. Gas den Tub Shed Deck Must See \$14,000</p> <p>SKYLINE MUST SEE! 3 Bed rooms 2 Baths Includes Stove Refrgerator Dishwasher Gas bags 3 spaces & Shed \$28,200</p> <p>SKYLINE MODEL HOME SWEET HOME! 3 Bedrooms 2 Baths Includes Stove Refrgerator Gas bags 3 Spaces Laundry Room & Shed \$29,900</p> <p>Nov Schools</p> <p>QUALITY HOMES IN HIGHLAND HILLS ESTATES on Beech Rd. N. of G and Pave (248) 474-0320</p> <p>HANDYMAN SPECIAL!</p> <p>24 x 56 3 bed 2 bath appliances Only \$13,900</p> <p>16 x 68 2 bed 2 bath Only \$7,900</p> <p>In Canton QUALITY HOMES at Sherwood Village Wayne Westland Schools on the southeast corner of Michigan Ave. & Haggerty Rd (734) 397-7774</p> <p>For the best auto classifications check out the Observer & Eccentric Newspaper It's all about RESULTS!</p>	<p>Resort & Vacation Property 3800</p> <p>FLA MONTHLY RENTAL Bonita Springs Condo 2 bdrm 2 bath 1700 sq ft 1st floor 22 ft Lana attached garage pool club house golf gated REDUCED 248 342 0871 or 586 350 5142</p> <p>Lots & Acreage/Vacant 3820</p> <p>FARMINGTON HILLS Buildable lot all utilities available 8 mile and Gill area \$75,900 248 563 2737</p> <p>Real Estate Wanted 3870</p> <p>AVOID FORECLOSURE! Trouble selling your house? We'll buy or lease your house make your payments do repairs close quickly any area any price any condition 248-496 0514</p> <p>I BUY HOUSES Any area condition or price Close quickly 247 call 248 232 6336</p> <p>Cemetery Lots 3880</p> <p>WESTLAND 2 Great plots Vault and double plaque at Cadillac Memorial Gardens West List \$7500 asking \$6200 Call (313) 277 1269</p> <p>WESTLAND Cadillac Memorial Gardens West 60 plots will sell in pairs 50% off market price (904) 321 4216</p> <p>WHITE CHAPEL - TROY 8 lots most desirable location \$2200 or best offer (941) 204 0007</p> <p>Commercial/Industrial/Retail For Sale 3880</p> <p>Plymouth Commercial/Multi-Family For Sale 1 On Ann Arbor Tr 176 frontage Development opportunity \$1,495,000 2 3 Family 1 blk from Main St \$353,000 3 3 Family on Ann Arbor Tr Super cond Fully leased \$295,000 C21 Curran & Christie Commercial 313-563 4210</p> <p>Land 3880</p> <p>HOWELL/MARION TWP 3 Country Acres Perked w/Driveway \$78,000 Call (517) 546 6478</p>
---	---	--	---	--	--	--	---	---

Observer & Eccentric



Apartments

HOMETOWNlife.com

<p>4000's Real Estate For Lease</p> <table border="1"> <tr><td>4000</td><td>Apartments/Unfurnished</td></tr> <tr><td>4010</td><td>Apartments/Furnished</td></tr> <tr><td>4020</td><td>Condos/Townhouses</td></tr> <tr><td>4030</td><td>Duplexes</td></tr> <tr><td>4040</td><td>Flats</td></tr> <tr><td>4050</td><td>Homes For Rent</td></tr> <tr><td>4060</td><td>Lakefront/Waterfront</td></tr> <tr><td>4080</td><td>Mobile Homes/Rentals</td></tr> <tr><td>4090</td><td>Southern Rentals</td></tr> <tr><td>4100</td><td>Time Share Rentals</td></tr> <tr><td>4110</td><td>Vacation Resort/Rentals</td></tr> <tr><td>4120</td><td>Living Quarters To Share</td></tr> <tr><td>4140</td><td>Rooms For Rent</td></tr> <tr><td>4200</td><td>Halls/Bu Items</td></tr> <tr><td>4210</td><td>Residence To Exchange</td></tr> <tr><td>4230</td><td>Commercial/Industrial</td></tr> <tr><td>4300</td><td>Garage/Mini Storage</td></tr> <tr><td>4400</td><td>Wanted To Rent</td></tr> <tr><td>4410</td><td>Wanted To Rent</td></tr> <tr><td>4500</td><td>Furniture Rental</td></tr> <tr><td>4560</td><td>Rental Agency</td></tr> <tr><td>4570</td><td>Property Management</td></tr> <tr><td>4580</td><td>Lease/Option To Buy</td></tr> <tr><td>4590</td><td>House Sitting Service</td></tr> <tr><td>4620</td><td>Home Health Care</td></tr> <tr><td>4640</td><td>Misc. To Rent</td></tr> </table> <p>1-800-579-SELL</p>	4000	Apartments/Unfurnished	4010	Apartments/Furnished	4020	Condos/Townhouses	4030	Duplexes	4040	Flats	4050	Homes For Rent	4060	Lakefront/Waterfront	4080	Mobile Homes/Rentals	4090	Southern Rentals	4100	Time Share Rentals	4110	Vacation Resort/Rentals	4120	Living Quarters To Share	4140	Rooms For Rent	4200	Halls/Bu Items	4210	Residence To Exchange	4230	Commercial/Industrial	4300	Garage/Mini Storage	4400	Wanted To Rent	4410	Wanted To Rent	4500	Furniture Rental	4560	Rental Agency	4570	Property Management	4580	Lease/Option To Buy	4590	House Sitting Service	4620	Home Health Care	4640	Misc. To Rent	<p>BIRMINGHAM 1 MONTH FREE To Qualified Applicants Studios and 1 & 2 bedrooms available in town Birmingham at the 955 Building Call Jess ca (248) 645 1191</p> <p>BIRMINGHAM MANORS 1 bdrm newly decorated terrace air pool gas heat water dishwasher blinds parking storage Shop dine close by \$650 Jan 1 (248) 646 6777</p> <p>Call to place your ad at 1-800-579-SELL(7355)</p>	<p>Franklin Palmer EHO Newly Renovated 1 Bedrooms w th FREE Heat from \$525 \$300 Security Depos t (866) 267-8640 On Palmer Rd Between Lilley & Sheldon www.cmproperties.net</p> <p>CANTON We have new homes for rent. Pets welcome Call Sandy at Sun Homes for details at 888 304 8941 Skyline/Clayton Retailer</p> <p>CANTON BRAND NEW Unique Terrace Carriage House Townhome and Theatre Flat floor plans Garages and fireplaces available Includes full size washer and dryer and 9ft ceilings 1 2 & 3 bdrms in the superb Cherry Hill Village location Call 888 658 7757 or visit online uptownapts.com</p>	<p>Dearborn Dearborn Club EHO REDUCED RATES & Security Deposit! FREE HEAT & WATER! Apartments from \$550 Townhomes from \$795 (866) 534-3358 On Inkster Rd Just N of Ford Rd www.cmproperties.net</p> <p>Dearborn Heights CAMBRIDGE APARTMENTS FREE RENT UNTIL 2-1-06 CALL NOW! Free Heat (313) 274-4765 (www.yorkcommunities.com Equal Housing Opportunity)</p> <p>FARMINGTON HILLS 1 bdrm 1/2 Month Free! Spacious 1 & 2 bdrm Laundry in unit Water & carport incl \$675 \$690 (586) 254 9511</p>	<p>Farmington Grand River Middlebelt Clarenceville School D strict CEDARIDGE APARTMENTS Limited Time Special 1 Bedroom \$600 2 Bedroom \$700 Vertical blinds carpeting storage w/in apt (Enter on Tulane 1 block W of Middlebelt S side of Grand River) Model Open Daily 1 6 Except Wednesday 248-471-5020</p> <p>Farmington Hills EHO CHATHAM HILLS 2 BDRM SPECIAL! Select Units As Low As \$680 *REDUCED Sec Deposit * FREE Water * Indoor Pool * Attached Garages (866) 588 9761 On Grand River Btwn Halsted & Drake www.cmproperties.net</p> <p>FARMINGTON HILLS Mobile homes 1 & 2 bedroom appliances No pets From \$400/month 8 Mile/Merriman 248 477 2080 Call to place your ad at 1-800-579-SELL(7355)</p>	<p>Farmington Hills TIMBERIDGE APARTMENTS 30310 Timberidge Circle N of 8 Mile on Truck between Middlebelt and Orchard Lake 1 Bedroom - \$575 2 Bedroom \$665 Immediate Occupancy CALL (248) 478-1487 Reduced Rental Rates (For a limited time only) Fully Equipped Kitchen Large 4x6 Storage Room Carpets Available On-Site Laundry Facilities Swimming Pool Basketball Court</p> <p>Farmington Hills WALNUT CREEK HOLIDAY SPECIAL (On Site Manager) 700 + sq ft 1 bdrm only Low Security Deposit STARTING AT \$545/Mo Call (248) 961 2753</p> <p>FARMINGTON HILLS Annege Apts Heat Included! 1 bed room \$485 Appliances carpeting 9 Mile/ Middlebelt 248 478 7489</p> <p>FARMINGTON PLAZA APTS ASK ABOUT OUR SPECIALS Deluxe 1 bedroom \$600 Includes heat & water (248) 478 8722</p> <p>FIVE Five Five ONE MONTH FREE To Qualified Applicants Studios 1 & 2 bedrooms available in town Birmingham 555 S Old Woodward Call Jessica (248) 645 1191</p>	<p>GARDEN CITY 2 bdrm refrigerator stove heat & water included \$650 Mint cond 313 645 0348</p> <p>GARDEN CITY 1 2 bdrm Newly decorated Heat water appliances incl \$510 \$550 734 261 6863/ 734 464 3847</p> <p>KEEGO HARBOR 2 bdrm Cass Lakefront Immaculate heat incl free month \$895 (248) 770 7067</p> <p>LIVONIA FAIRFIELD ARMS 14950 FAIRFIELD \$99 moves you in! 1 & 2 bdrm \$50 off 1st year's lease 734 516 0539 *on approved credit</p> <p>LYON TWP 2 br 1.5 bath patio 1150sq ft \$750/\$825+\$500 security (248) 640 7531 Northville Novi Road North of 8 Mile</p> <p>TREE TOP APARTMENTS Stunning 1 bedroom with den from \$765 includes HEAT and washer/dryer Charming 1 bedroom from \$645 Covered parking For an appointment please call (248) 347 1690 EHO</p> <p>NOVI Meadowbrook N of 10 Mile ONE MONTH FREE Hurry includes our beautiful fully remodeled apartments with new kitchens and in unit washer dryers! Limited availability come see why! EHO</p> <p>TREE TOP MEADOWS (248) 348 9590 A word to the wise when looking for a great deal check the Observer & Eccentric Classifieds!</p>	<p>Novi Waterview Farms EHO AMAZING RATES! As Low As \$495 for 2 Bdrms \$635 for 1 Bdrms * REDUCED Sec Deposit * SOUND CONDITIONED * FREE city water * HUGE floor plans (866) 534-3356 On Pontiac Trail Just East of Beck Rd www.cmproperties.net</p> <p>Novi WESTGATE VI EHO Apartments AMAZING RATES! As Low As \$495/Month * REDUCED Sec Deposit * FREE City Water * Carpets Included (866) 238 1153 On West Park Dr Just S of Pontiac Tr www.cmproperties.net</p> <p>OAK PARK NORTH LINCOLNBRIAR APARTMENTS * 2 bedroom 1.5 bath to 1160 sq ft * 3 bedroom 1.5 bath 1380 sq ft + full basement FROM \$795 FREE GAS HEAT! (248) 968-4792 Come See Our Renovated Kitchens Ask about our move in Specials</p>
4000	Apartments/Unfurnished																																																										
4010	Apartments/Furnished																																																										
4020	Condos/Townhouses																																																										
4030	Duplexes																																																										
4040	Flats																																																										
4050	Homes For Rent																																																										
4060	Lakefront/Waterfront																																																										
4080	Mobile Homes/Rentals																																																										
4090	Southern Rentals																																																										
4100	Time Share Rentals																																																										
4110	Vacation Resort/Rentals																																																										
4120	Living Quarters To Share																																																										
4140	Rooms For Rent																																																										
4200	Halls/Bu Items																																																										
4210	Residence To Exchange																																																										
4230	Commercial/Industrial																																																										
4300	Garage/Mini Storage																																																										
4400	Wanted To Rent																																																										
4410	Wanted To Rent																																																										
4500	Furniture Rental																																																										
4560	Rental Agency																																																										
4570	Property Management																																																										
4580	Lease/Option To Buy																																																										
4590	House Sitting Service																																																										
4620	Home Health Care																																																										
4640	Misc. To Rent																																																										

THE APARTMENT SPECIALISTS

Isn't It About Time You Got Your Own Place?

<p>Westland</p> <p>Parkcrest Apts. Designed with ROOMATES in MIND! Across from Meljers Livonia Schools (734) 522-3013</p>	<p>Plymouth</p> <p>Carriage House Move In Special! FREE HEAT Ph 1 CENTRAL AIR Ph 2 Corner of Haggerty & Joy (734) 425-0930</p>
<p>Wilderness</p> <p>SPACIOUS!! 2 Bdrms 1000 sq ft CARPORTS POOL WASHER & DRYER in de unit Livonia Schools (734) 425-5731</p>	<p>Garden City</p> <p>Luna Apts. Move In Special! Central Air Near Westland mail (734) 425-0930</p>
<p>Take advantage of one of these great specials today!</p> <p>Village Apts. FREE HEAT HUGE Bathrooms Bordering Westland (734) 425-0930</p> <p>734-451-5210 www.ssleasing.com</p>	

Franklin Square Apartments

1 & 2 Bedrooms from \$615

- *FREE HEAT & WATER
- *Livonia Schools
- *Convenient to I-96
- *Security Deposit from \$200
- *OPEN 7 DAYS!

Call for details 734-427-6970

Two Months Free!

1 & 2 BEDROOMS from only \$620
*Free Heat & Water * 2 Bedrooms have 1 1/2 Baths *Security Deposit from \$200

WAYNEWOOD Apartments
(734) 326-8270
Open 7 Days! * Call for details

www.hometownlife.com

HOLIDAY SPECIAL!

FORDHAM GREEN APARTMENTS
1, 2 & 3 Bedroom Apartments & Townhomes
5600 Fordham Circle Canton MI 48187 (734) 981-3700
fordhamgreen@homeproperties.com

Heat & Gas Included
Pets Welcome - Small Dogs and Cats

1 to 2 Months FREE* on Select Floor plans
\$0 Security Deposit*
*Some restrictions apply

PONTIAC
A GREAT PLACE TO LIVE!
Move-In Special \$294 moves you in!
Newly renovated units A great community Weekend resident gatherings in our updated clubhouse
549 Lakewood Drive South Lyon, MI 48178 (248) 437 3303 Office pontiac@bcglobal.net

hometownlife.com



CROSSWORD PUZZLER

ACROSS
 1 Miles away
 5 E mail option
 9 Old crone
 12 Omigod!
 13 Great Lakes port
 14 Ms Thurman
 15 Love god
 16 Nun's room
 17 Soggy ground
 18 Devotee's suffix
 20 Walrus teeth
 22 Sparkle
 25 Ritzy
 27 Close relative
 28 Brownish fruit
 29 Renown
 33 Made tracks
 34 Dog days in Dijon
 35 Mouth part
 36 Physics particle
 38 Dactyl
 39 Inventory wd
 40 Roasting chamber

42 Nobel Prize category
 43 Luan-sharking
 46 Which person
 47 Temper
 48 Andes empire
 51 Sweater material
 55 Bullring yell
 56 Kind of miss
 57 Sea eagle
 58 Soap pad brand
 59 Mineral finds
 60 Bug repellent

DOWN
 1 Yes vote
 2 Evergreen tree
 3 GI mail drop
 4 Stand up to
 5 Faction
 6 Sooner than anon
 7 Goose egg
 8 Shoulder muscles

9 Wheel parts
 10 On a rampage
 11 Comedian's stock
 19 Library sound
 21 TV band

22 Raise corn
 23 Hula-dance feast
 24 Livy's year
 25 Rock climber's aid
 26 Painted arch
 28 Big celebration
 30 Swit co-star
 31 Var topics
 32 Touche provoker
 37 Neither's mate
 39 Ceterwaulead
 41 Striving to win
 42 Soil test
 43 Pilots sightings
 44 Corn holder
 45 Comanches kin
 46 Treaties end them
 49 Maiden-name indicator
 50 Trippet
 52 Mother lode
 53 Four quarters
 54 Sanction

CHECK YOUR ANSWERS HERE



© 2005 United Feature Syndicate, Inc.

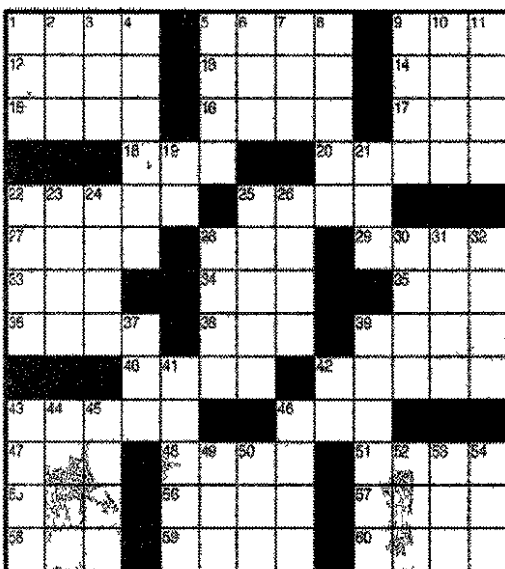

PUZZLE ENTHUSIASTS Get more puzzles in Random House Crossword MegaOmnibus Vols. 1 & 2

Compliments of the MCAR REALTOR

Metropolitan Consolidated Association of Realtors

Don't take a chance...
 place your ad in The Observer & Eccentric Classifieds today!
 1-800-579-SELL

\$200 MOVES YOU IN!
 1 MONTH FREE
 Rent SameDay-Electronic Bonus
 On Select Units Hurry! Call Today!
 Cedar Lake Apartments in Northville
 La used on 6 MI between Haggerty and Northville Roads 2 m. e. w. of I 275
1 & 2 Bedroom Apartments
 • Private Entry • Full Size Washer & Dryer
 • Small Pets Welcome • Water Included
 Call today for details & pricing info!
248-348-1830
 www.cedarlakeapartments.com

CANTON
SPACIOUS 1 & 2 BEDROOM

- Washer/Dryer hook-up
- Self cleaning oven
- Vertical Blinds
- Swimming Pool
- New Fitness Center
- Pets Welcome
- Furnished Apts Available

Ask about our Winter Specials!

Autumn Ridge APARTMENT
 Cherry Hill at I 275
734-397-1080
 Call Today For An Appointment!

Apartment/Unfurnished 4000
Plymouth Hillcrest Club
 \$0 SECURITY DEPOSIT! With Qualifying Credit
FREE HEAT!
 From \$520/mo
 (866) 235 5425
 On Haggerty
 S of Plymouth Rd
 www.cmpproperties.net

PLYMOUTH Beautiful Place Beautiful Price
 • private entrance/patio
 • washer/dryer hook ups
 • inside storage central air
 • pets welcome
 • single story ranch style apartments
 • minutes from Hines Park
PRINCETON COURT
 734-459-6640 EHO

PLYMOUTH BROUGHAM MANOR
 1 & 2 Bedroom Apts.
 ASK ABOUT OUR SPECIALS!
 From \$590 (734) 455 1215

FREE RENT UNTIL 2-1-06 CALL NOW!
 FREE HEAT & WATER Newly Upgraded
 1 & 2 Bedrooms
Plymouth Manor Plymouth House
 Close to downtown Plymouth!
 734 455-3880
 www.yorkcommunity.com
 Equal Housing Opportunity

PLYMOUTH Park Manor
 Apts Dc Special! 2 bdrm non smoking \$540 incl heat No pets 1 parking space per apt 734 454 9274

Plymouth SHELDON PARK APARTMENTS
 Spacious 1 & 2 bedroom central air Carport Swimming pool Close to shopping \$565 \$665 Ask about our specials
 Call (734) 453 8811

PLYMOUTH DOWNTOWN
 1 bdrm air coin laundry private wood deck Lg storage Heat/water included \$575/mo 313 682 7225

Plymouth Winter Special
 Large 1 bd m sto age laundry \$550 incl heat/water \$650 total move in 248 446 2021

PLYMOUTH 2 bdrm 2 bath
 Laundry air all appliances Close to everything \$825 734 455 4169

PLYMOUTH Old Village Lg 1 bdrm
 \$520 1st month free + sec Stove & refrigerator included (586) 344 6624

PLYMOUTH SQUARE APTS
 50% OFF FIRST 3 MONTHS RENT
 1 & 2 bedroom central air pool From \$580 734 455 6570

REDFORD SPECIAL! 26053
 Five Mile Road 1 bedroom Air Carport available \$550 313 538 8553

ROYAL OAK Between 12 & 13 Mile off Coolidge 1 bed room apt newly redecorated carpet \$540/mo Heat & water included (248) 488 2251

Apartment/Unfurnished 4000
ROYAL OAK (NORTH)
 1 Bedroom bath Laundry facilities No pets Basement Immediate Occupancy Approx 700 sq ft Includes heat water stove refr gerator microwave gar d disposal a/c assigned parking updated clean & quiet \$570/mo 248 740 9836

ROYAL OAK Deluxe 2 bed room 1000 sq ft starting at \$685 across from Beaumont hospital 248 549 1761

ROYAL OAK Spacious 1 bed room
 hardwood floors c/a near downtown \$875/mo ShareNet Realty 248 642 1620

South Lyon MEADOWS OF SOUTH LYON
 townhouse style apts 2 & 3 bdrm laundry dry free cable Starting at \$750 per mo 248 767 4207

Affordable! Great Location!
 What more could you ask for? Enjoy the comfort and convenience you deserve in our spacious one bedroom homes Just one mile from I 696 I 96 M 10 (The Lodge) and Southfield Freeway you will enjoy all the wonderful things that Metro Detroit has to offer. Come visit your new home today! Features:
 • Water included
 • Fully equipped kitchens
 • On Site laundry
 • Close to shopping dining
 • Carport included
 • 24 hour emergency maintenance
One Bedrooms \$595
 Directions From I 696 exit Greenfield North to 11 Mile Rd Go west on 11 Mile and we are one half mile down on the left by apt only 248 557 1582 586 754 7816 Professionally managed by First Holding Corporation

TROY'S NICEST 1 bdrm apt incl full size washer/dryer carport C/A dishwasher pergola/carporting vertical blinds start at \$110/week heat & water \$745 No pets Specials 248 398 0960

Walled Lake \$599* FOR A TOWNHOUSE!
 • Best price anywhere!
 • 2 Bd m 1 1/2 bath TOWNHOMES
 Open 7 days a week (248) 624-6606
 *with good credit

WAYNE EFFICIENCY APT
 All utilities no lease weekly/monthly rates cable incl start at \$110/week (734) 728 0738

WEST BLOOMFIELD Clean quiet renovated 1 bdrm Non smoking Lake access \$450 \$800/mo 248 245 5393

Westland Hawthorne Club
1 MONTH FREE On 2 Bedrooms
\$300 OFF 1st MONTH'S RENT On 1 Bedrooms
 (866) 262-3697
 On Merriman Rd between Ann Arbor Tr & Warren Rd
 www.cmpproperties.net

Westland EHO
Huntington On The Hill
\$300 OFF 1st Month's Rent On 1 Bdrms
FREE HEAT! New Fitness Center Now Open!
 (866) 413 1672
 On Ann Arbor Trail Between Middlebelt & Inkster Rds
 www.cmpproperties.net

Westland WEST HAMPTONS
 The perfect location at great rates 1 bdrm apts starting from \$499 Short term leases available! Heat & water included Rent to own option 734 427 1997
 On Warren Ave E of Middlebelt Rd OPEN DAILY

WESTLAND CAPRI WINTER SPECIAL
FIRST MONTH RENT FREE
 California Style Apts
 • 1 bedroom from \$565
 • Water included
 • Cathedral ceilings
 • Balconies
 • Carport
 • Fully carpeted
 • Vertical blinds
 • Great location to malls
 • Lvonla school system
 (734) 261 5410

Edgewood Court North
 Grant at Davs Not a Condo Luxury Townhouse Rentals Live in style without the commitment of ownership • Spacious updated 2 bed /1 1/2 bath with private patio full basement hardwood flooring covered parking Short distance to downtown & shopping \$1080 per mo + heat just ask Alce

Maple Road Townes Maple at Columbia (east of Adams) Close to downtown from these quaint updated 1 bedroom townhomes (\$820) and 1 bedroom apts (\$725) in vly covered building

Edgewood Court 14 Mile between Pierce and Greenfield Beautiful kitchens highlight these updated 2 bed 1 bath townhouses with covered parking \$995

BLOOMFIELD HILLS 1 Bdrm washer/dryer large storage unit Club house pool \$660/mo (248) 310 9129

CANTON CHERRY HILL VILLAGE
 Brand New 2 Bdrms 2 baths 2 garages Bsmnt 1800 sq ft \$1500/mo 248 761 1008

FARMINGTON 3 Bdrm 2 bath condo Cathedral/Hardwood Furnished or Unfurnished \$1450mo 9eth 734 521 0185

Apartment/Unfurnished 4000
WESTLAND Blue Garden Apartments from \$530*
AMAZING! MOVE IN SPECIAL
\$100 OFF 1st 7 MONTHS RENT REDUCED SEC DEPOSIT
 • HEAT/WATER INCLUDED
 • POOL
 • CLUBHOUSE
 • CABLE READY
 • Pet Welcome
 Spacious 1 and 2 bdrm apartments with Balcony Rents from \$530*
 Cherry Hill near Merriman
Call for Details* 734-729-2242

Westland FREE RENT UNTIL 2-1-06 CALL NOW!
ORCHARDS OF NEWBURGH
 • Larger Apartments
 • 1 & 2 Bedroom plans
 • Playground Area
 • Pool & Clubhouse
 • Carport included
 (734) 729-5090
 www.yorkcommunity.com
 Equal Housing Opportunity

Westland FREE RENT UNTIL 2-1-06 CALL NOW!
VENOY PINES APARTMENTS
 NEWLY RENOVATED KITCHENS & BATHS
 1 & 2 bedroom apts some with f replace Clubhouse
 (734) 261-7394
 www.yorkcommunity.com
 Equal Housing Opportunity

Westland WEST HAMPTONS
 The perfect location at great rates 1 bdrm apts starting from \$499 Short term leases available! Heat & water included Rent to own option 734 427 1997
 On Warren Ave E of Middlebelt Rd OPEN DAILY

Westland WEST HAMPTONS
 The perfect location at great rates 1 bdrm apts starting from \$499 Short term leases available! Heat & water included Rent to own option 734 427 1997
 On Warren Ave E of Middlebelt Rd OPEN DAILY

Westland WEST HAMPTONS
 The perfect location at great rates 1 bdrm apts starting from \$499 Short term leases available! Heat & water included Rent to own option 734 427 1997
 On Warren Ave E of Middlebelt Rd OPEN DAILY

Westland WEST HAMPTONS
 The perfect location at great rates 1 bdrm apts starting from \$499 Short term leases available! Heat & water included Rent to own option 734 427 1997
 On Warren Ave E of Middlebelt Rd OPEN DAILY

Westland WEST HAMPTONS
 The perfect location at great rates 1 bdrm apts starting from \$499 Short term leases available! Heat & water included Rent to own option 734 427 1997
 On Warren Ave E of Middlebelt Rd OPEN DAILY

Westland WEST HAMPTONS
 The perfect location at great rates 1 bdrm apts starting from \$499 Short term leases available! Heat & water included Rent to own option 734 427 1997
 On Warren Ave E of Middlebelt Rd OPEN DAILY

Westland WEST HAMPTONS
 The perfect location at great rates 1 bdrm apts starting from \$499 Short term leases available! Heat & water included Rent to own option 734 427 1997
 On Warren Ave E of Middlebelt Rd OPEN DAILY

Westland WEST HAMPTONS
 The perfect location at great rates 1 bdrm apts starting from \$499 Short term leases available! Heat & water included Rent to own option 734 427 1997
 On Warren Ave E of Middlebelt Rd OPEN DAILY

Westland WEST HAMPTONS
 The perfect location at great rates 1 bdrm apts starting from \$499 Short term leases available! Heat & water included Rent to own option 734 427 1997
 On Warren Ave E of Middlebelt Rd OPEN DAILY

Westland WEST HAMPTONS
 The perfect location at great rates 1 bdrm apts starting from \$499 Short term leases available! Heat & water included Rent to own option 734 427 1997
 On Warren Ave E of Middlebelt Rd OPEN DAILY

Westland WEST HAMPTONS
 The perfect location at great rates 1 bdrm apts starting from \$499 Short term leases available! Heat & water included Rent to own option 734 427 1997
 On Warren Ave E of Middlebelt Rd OPEN DAILY

Westland WEST HAMPTONS
 The perfect location at great rates 1 bdrm apts starting from \$499 Short term leases available! Heat & water included Rent to own option 734 427 1997
 On Warren Ave E of Middlebelt Rd OPEN DAILY

Westland WEST HAMPTONS
 The perfect location at great rates 1 bdrm apts starting from \$499 Short term leases available! Heat & water included Rent to own option 734 427 1997
 On Warren Ave E of Middlebelt Rd OPEN DAILY

Westland WEST HAMPTONS
 The perfect location at great rates 1 bdrm apts starting from \$499 Short term leases available! Heat & water included Rent to own option 734 427 1997
 On Warren Ave E of Middlebelt Rd OPEN DAILY

Westland WEST HAMPTONS
 The perfect location at great rates 1 bdrm apts starting from \$499 Short term leases available! Heat & water included Rent to own option 734 427 1997
 On Warren Ave E of Middlebelt Rd OPEN DAILY

Westland WEST HAMPTONS
 The perfect location at great rates 1 bdrm apts starting from \$499 Short term leases available! Heat & water included Rent to own option 734 427 1997
 On Warren Ave E of Middlebelt Rd OPEN DAILY

Westland WEST HAMPTONS
 The perfect location at great rates 1 bdrm apts starting from \$499 Short term leases available! Heat & water included Rent to own option 734 427 1997
 On Warren Ave E of Middlebelt Rd OPEN DAILY

Westland WEST HAMPTONS
 The perfect location at great rates 1 bdrm apts starting from \$499 Short term leases available! Heat & water included Rent to own option 734 427 1997
 On Warren Ave E of Middlebelt Rd OPEN DAILY

Westland WEST HAMPTONS
 The perfect location at great rates 1 bdrm apts starting from \$499 Short term leases available! Heat & water included Rent to own option 734 427 1997
 On Warren Ave E of Middlebelt Rd OPEN DAILY

Westland WEST HAMPTONS
 The perfect location at great rates 1 bdrm apts starting from \$499 Short term leases available! Heat & water included Rent to own option 734 427 1997
 On Warren Ave E of Middlebelt Rd OPEN DAILY

Apartment/Unfurnished 4000
Westland HAVE A MERRY CHRISTMAS LIVING AT WESTERN HILLS
FREE HEAT! FREE RENT! FREE WATER \$199
MOVES YOU IN!
 1 Bdrm \$489
 2 bdrm \$559
 (734) 729-6520
 Mon Fri 8 6pm Sat 10 2
 * CONDITIONS APPLY

Apartment/Furnished 4010
Birmingham 700 Ann St One bedroom 1 bath living room kitchen utilities included All amenities Small building Laundry facilities carport \$975/mo 248 546 3056

BIRMINGHAM Downtown
 Townsend 1 bdrm completely furnished Off street parking \$995/mo incl utilities 6 mo minimum Molly 248 642 7789 or 248 705 8281

BIRMINGHAM Downtown lux
 unous 2 bdrm 2 bath apt available Jan 1 May 1 248 647 9207 248 761 2014

FARMINGTON HILLS Park Motel
 Furnished rooms efficiency & apts from \$150/week No deposit 248 474 1324

AN OLDE REDFORD TOWN HOME
 2 bdrm carpeted blinds bsmt heat water cable \$725 + security 248 735 0877

BELLEVILLE 2 bdrm 1 1/2 bath all appliances water & gas free Carport No pets non smoking \$750 mo + security 734 461 1861

BIRMINGHAM 1 bdrm remodeled condo Lease w/ option to purchase or short term lease avail 248 790 1256

BIRMINGHAM RENTAL SPECIALISTS
 Edgewood Court North Grant at Davs Not a Condo Luxury Townhouse Rentals Live in style without the commitment of ownership • Spacious updated 2 bed /1 1/2 bath with private patio full basement hardwood flooring covered parking Short distance to downtown & shopping \$1080 per mo + heat just ask Alce

Maple Road Townes Maple at Columbia (east of Adams) Close to downtown from these quaint updated 1 bedroom townhomes (\$820) and 1 bedroom apts (\$725) in vly covered building

Edgewood Court 14 Mile between Pierce and Greenfield Beautiful kitchens highlight these updated 2 bed 1 bath townhouses with covered parking \$995

BLOOMFIELD HILLS 1 Bdrm washer/dryer large storage unit Club house pool \$660/mo (248) 310 9129

CANTON CHERRY HILL VILLAGE
 Brand New 2 Bdrms 2 baths 2 garages Bsmnt 1800 sq ft \$1500/mo 248 761 1008

FARMINGTON 3 Bdrm 2 bath condo Cathedral/Hardwood Furnished or Unfurnished \$1450mo 9eth 734 521 0185

Condos/Townhouses 4020
LIVONIA First mo rent free 2 bdrm 2 bath screen porch appliances \$1050/mo D&H Properties 248 737 4002

NORTHVILLE RENT OR RENT TO OWN
 Large 1 bdrm 1 bath condo \$675 rent 1st Mo Rent FREE! 24 hr recorded message 866 237 2647 ext 11

NORTHVILLE 1609 sqft 2 bdrm 2 1/2 bath 2 car built 2003 Stainless washer/dryer \$1500 734 502 4512

PLYMOUTH 2 bdrm facing woods newly renovated garage 2 1/2 bath deck no pets \$980 (734) 354 9613

PLYMOUTH Charming Ranch Condo
 Right downtown Cathedral ceilings skylights fireplace balcony open floor plan Tastefully decorated and clean Freshly painted neutral throughout \$995/month lease also for sale Century 21 Hartford North 734-525 9600

SOUTH LYON New 2 bdrm bsmt hardwood floors close to town \$785/mo D&H Properties 248 737 4002

SOUTHFIELD TOWNHOUSE/CONDO
 2 bdrm 2 1/2 baths full bsmt 2 car garage 1600 sq ft no pets 1 1/2 month sec deposit 248 855 8110

SOUTHFIELD Beautiful 2 bdrm 2 bath hardwood floors new appliances \$750/mo Share Net Realty 248 642 1620

Belleville 2 bdrm hwd floors updated Kitchen w/all appliances new vinyl windows new blinds bsmt w/washer & dryer hook up & possible 3rd bedroom \$625/mo \$1000 sec dep 2 units avail now pets negotiable Call Tina 734 416 8736

BIRMINGHAM Lower 2 bdrm
 hardwood floors bsmt air no pets \$1100/mo (248) 644 1689

CANTON 3 bdrm 1 1/2 bath Appliances No Pets Ford/ Sheldon area \$865/mo Call/4 248 514 0585

Dearborn Area EVERGREEN & FORD RD
 Newly renovated 2 bdrm duplex w/ bsmt near Fairlane HFCC & U of M Ext \$525 + sec Avail now! 248 388 2905

GARDEN CITY 1 bdrm duplex no smoking appliances no pets \$495/mo Leave message 734 425 5305

HAZEL PARK 2 bedroom upper \$575/month includes heat water cable and garage parking (248) 398 4935

NORWAYNE 2 bdrm remodeled kitchen & bath newer carpet freshly painted nice location \$569/mo 313 278 0282

Westland 2 bedroom Full basement Clean & neat Quiet neighborhood Immediate occupancy From \$645/month Call Jamie 734 721 8111

WESTLAND Norwayne area Duplex 31581 Alpena 2 bdrm \$540 mo + security 32406 Lapeer 3 bdrm \$650 + sec Call (248) 428 0573

WESTLAND/NORWAYNE
 2 bedroom Clean Remodeled kitchen! Under \$560/ security 734 416 9799

Berkley Lower flat 1207 Dorthea 2 bdrm 6 rooms Updated Appliances Clean \$850 per mo 2 yr \$925 one year lease (248) 770 1964

BIRMINGHAM Downtown
 1 bedroom upper flat includes heat garage & balcony \$800 248 645 0171

FERDALE 467 W Chester field 1 bdrm upper \$650 2 bdrm lower + office \$800 Both nice 1 1/2 mo sec credit check 248 855 0616

Flats 4040
PLYMOUTH DOWNTOWN
 Great location seconds to downtown 1 bdrm lower flat Updated thruout freshly painted deck hardwood floors neutral decor large eat in Kitchen w/all appliances Bonus Room could be office or 2nd bed room Bsmnt w/extra storage washer/dryer Central Air & vinyl windows 1 yr lease \$695/mo \$1000 sec dep Pets negotiable 641 Forest St Ava l now Call Tina 734-416 8736

Homes For Rent 4050
BAD CREDIT?
 YOU CAN STILL BUY A HOME WITH SO DOWN IN ANY AREA!
 Short term employment OK Bankruptcy OK Call Randy Lesson, METRO FINANCE 248-709-2244 metrofinance.net

BIRMINGHAM
 2604 Manchester renovated 3 bdrm 2 bath hardwood floors all appliances fireplace finish bsmt garage fenced deck \$1595/mo 248 761 0627

BLOOMFIELD Well maintained 4 bdrm 2 bath Ranch fire place attached garage \$2150 ShareNet Realty 248 642 1620

CANTON 4 bdrm 2 1/2 bath deck fireplace appliances 2 car garage fenced yard bsmt c/a \$1500/mo 734 716 7827

CANTON We have new homes for rent! Pets welcome Call Sandy at Sun Homes for details at 898 904 8941 Skyline/Clayton Retailer

CANTON 3 bdrm ranch 2 1/2 detached garage \$1185/mo Call (734) 416 9799

CANTON 4 bdrm bsmt 2 car attached garage fireplace fenced yard pets okay all appliances \$1400/mo Derek 810 533 2342

CANTON TOWNSHIP

REAL ESTATE BRIEFS

Education Seminars

The Building Association of Southeastern Michigan is sponsoring the following seminars

■ 8 30 a.m. to 10 30 a.m. Thursday, Dec 1 -- "Condominium Nuts and Bolts When To Consider Using a Condominium Format" at BIA Headquarters, 30375 Northwestern Highway, Suite 100, Farmington Hills Registration fee is \$20 for BIA or Apartment Association of Michigan members and \$40 for guests (248) 862-1033

■ 8 a.m. to 4 p.m. Friday, Dec 2, "Builder's License Preparation Course" at BIA Headquarters, 30375 Northwestern Highway, Suite 100, Farmington Hills Material covered will include topics on the exam, laws and rules, construction drawings, codes, procedures, sample test questions and test tips Registration is \$200 (248) 862-1033

■ 8 30 a.m. to 10 30 a.m. Monday, Dec 5, "Convention Strategies" at BIA Headquarters, 30375 Northwestern Highway, Suite 100, Farmington Hills Registration fee is \$20 for BIA or Apartment Association of Michigan members and \$40 for guests (248) 862-1033

■ 8 30-10 30 a.m. Wednesday, Dec 7, "Extreme Success" seminar at Stagecrafters Baldwin Theatre, 415 S Lafayette, Royal Oak A discussion on risks that yield better results, new ways to deal with fear and how to break free from the "Struggle Syndrome" Registration fee is \$59 for sales and marketing

council members, \$89 for BIA or Apartment Association of Michigan members and \$109 for non-members and guests (248) 862-1033

■ 8 a.m. to noon Thursday, Dec 8, "Codes and Quality Control" at BIA Headquarters, 30375 Northwestern Highway, Suite 100, Farmington Hills Chuck Breidenstein of Builders Professional Services Group will discuss setting performance expectations, a superintendent's responsibilities regarding codes and will provide tips to enforce code compliance on the job site Registration fee is \$145 (248) 862-1033

■ 8 30 a.m. to 10 30 a.m. Monday, Dec 12, "Managing a Business for the Long Term" seminar at BIA Headquarters, 30375 Northwestern Highway, Suite 100, Farmington Hills Richard G. Willam, CPA, of Polk and Associates PLC will discuss strategic planning for the small to medium size business, exit strategies and business valuation Registration is \$20 for BIA or AAM members and \$40 for guests (248) 862-1033

■ 8 a.m. to 9 a.m. Friday, Dec 16, "Managers Roundtable" discussion at AAM headquarters, 30375 Northwestern Highway, Suite 100, Farmington Hills The program is free for Property AAM, PMC and BIA members and \$15 for guests Coffee and bagels will be provided (248) 862-1033

How To Classes

Oakland Builders Institute will offer the following

■ Builder's Pre-License Class -- This course will help those who want to subcontract the construction of their own home, real estate investors, developers and building trades people

Classes will be held 6-10 p.m., Monday/Wednesday, Dec. 5, 7, 12 & 14, at Henry Ford Community College, Dearborn Heights Campus, 22586 Ann Arbor Trail, Dearborn Heights, (313) 317-1500, \$189 for residents and \$208 for non-residents, plus a \$20 textbook and sample question fee, and 6-10 p.m., Tuesday/Thursday, Dec 6, 8, 13 & 15, at Berkshire Middle School, 21707 W 14 Mile, Beverly Hills, (248) 203-3800, \$190 plus \$20 for textbook and sample questions

Upbeat. Upscale. Uptown!

Uptown
apartment living

IMMEDIATE OCCUPANCY BRAND NEW!

Furnished four star monthly rentals also available!

- Thru-unit condo style design
- Attached garage*
- Private entrance
- State-of-the-art fitness center

One Bdrm from \$899
Two Bdrm from \$1160
Three Bdrm from \$1385

Available in select rentals only
888-723-2133
www.uptownapts.com

1275 to Ford Rd. Take Ford Road west 4 miles Turn left on Ridge Rd On the corner of Cherry Hill and Ridge Rd

OFFICE HOURS
MON FRI 9-6 SAT 10-5 SUN 12-5

CAREFREE living at an AFFORDABLE price, in LIVONIA'S most DESIRABLE area.



BROOKSIDE VILLAS

Ranch/Lofted Ranch Homes from \$290,000

- 1800-2100 sq ft plans available with first floor master suites
- 2 & 3 bedrooms, 2.5 baths, 2-car attached garages and basements
- Convenient to freeways, shopping and entertainment districts

(248) 476-3536

Conveniently located in Livonia • Farmington Road, between 7 and 8 Mile Rds.
3% Realtor commissions paid half at purchase agreement, half at closing

Phoenix Land Development

Sales Hours: 11 A.M. to 6 P.M. Daily - Closed Thursdays.

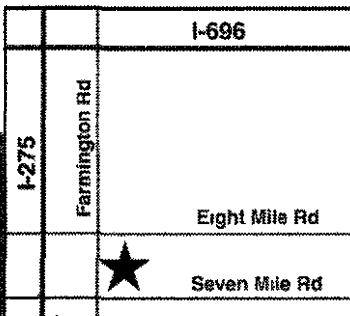

LUXURIOUS living at an AFFORDABLE price, in LIVONIA'S most DESIRABLE area.



BROOKSIDE ESTATES

Luxury Single Family Homes from the \$380's

- Single family homes, attached 2 and 3 car garages • 2500-2900 sq. ft., 4 bedrooms & 2.5 baths
- Highly regarded Livonia schools • Get to freeways easily
- Walkouts and so much more...

(248) 476-9960

Conveniently located in Livonia • Farmington Road, between 7 and 8 Mile Rds.
3% Realtor commissions paid half at purchase agreement, half at closing

Phoenix Land Development

Sales Hours: 11 A.M. to 6 P.M. Daily - Closed Thursdays.

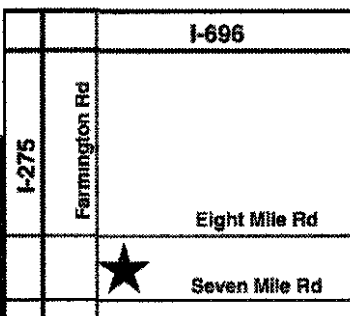

HOMES SOLD IN OAKLAND COUNTY

These are the Observer & Eccentric area residential real estate closings recorded the week of Aug 8-12 2005 at the Oakland County Register of Deeds office. Listed below are cities, addresses and sales prices.

City	Address	Sale Price
Birmingham	1207 Bird	\$276,000
Birmingham	1750 Bradford	\$225,000
Birmingham	529 Catalpa	\$336,000
Birmingham	1051 Chapin	\$660,000
Birmingham	1109 Derby	\$145,000
Birmingham	1858 Graefield	\$134,000
Birmingham	1481 Hazei	\$229,000
Birmingham	588 Larchlea	\$460,000
Birmingham	724 Madison	\$570,000
Birmingham	1380 Pierce	\$375,000
Birmingham	1889 Pine	\$490,000
Birmingham	1990 S Bates	\$206,000
Birmingham	1239 Webster	\$417,000
Birmingham	1860 Yorkshire	\$477,000
Bloomfield Hills/Township	150 Billingsgate	\$154,000
Bloomfield Hills/Township	1979 Devonshire	\$265,000
Bloomfield Hills/Township	434 Fox Hills	\$102,000
Bloomfield Hills/Township	2709 Indian Mound	\$1,060,000
Bloomfield Hills/Township	7410 Jackson Park	\$700,000
Bloomfield Hills/Township	7440 Jackson Park	\$435,000
Bloomfield Hills/Township	5645 Meadow Wood	\$3,500,000
Bloomfield Hills/Township	2845 Meadowood	\$785,000
Bloomfield Hills/Township	2409 Mulberry	\$129,000
Bloomfield Hills/Township	2499 Parcels	\$212,000
Bloomfield Hills/Township	2712 Rambling	\$306,000
Bloomfield Hills/Township	1793 S Hill	\$195,000
Bloomfield Hills/Township	903 Tartan	\$395,000
Bloomfield Hills/Township	1145 Timberview	\$247,000
Bloomfield Hills/Township	240 Warrington	\$900,000
Bloomfield Hills/Township	662 Wattles	\$313,000
Bloomfield Hills/Township	42160 Woodward	\$187,000
Farmington	33677 Alta Loma	\$160,000
Farmington	32718 Grand River	\$91,000
Farmington	31641 Lamar	\$195,000
Farmington	23021 Orchard Lake	\$105,000
Farmington	22824 Violet	\$145,000
Farmington Hills	37882 Amber	\$297,000
Farmington Hills	23103 Ashley	\$181,000
Farmington Hills	21410 Collingham	\$140,000
Farmington Hills	32040 Coronet	\$235,000
Farmington Hills	24514 Creekside	\$258,000
Farmington Hills	22772 Glenmoor	\$155,000
Farmington Hills	29362 Laurel	\$163,000
Farmington Hills	28767 Leamington	\$265,000
Farmington Hills	22279 Nearbrook	\$415,000
Farmington Hills	32626 Olde Franklin	\$330,000
Farmington Hills	34519 Princeton	\$275,000
Farmington Hills	38192 Saratoga	\$218,000
Farmington Hills	35088 Savannah	\$325,000
Farmington Hills	22391 Sheffield	\$388,000
Farmington Hills	33712 Stocker	\$186,000
Farmington Hills	30049 Stockton	\$189,000
Farmington Hills	31291 Stonegate	\$360,000
Farmington Hills	22139 Tuck	\$135,000
Novi	24815 Apple Crest	\$250,000
Novi	43042 Ashbury	\$480,000
Novi	24427 Bashian	\$159,000
Novi	30835 Centennial	\$218,000
Novi	22817 Cranbrooke	\$168,000
Novi	29345 Douglas	\$260,000
Novi	44634 Dunbarton	\$350,000
Novi	40624 Heatherbrook	\$235,000
Novi	44781 Huntingcross	\$385,000
Novi	40712 Ladene	\$254,000
Novi	42695 Morgan Creek	\$140,000
Novi	30251 Pennington	\$456,000
Novi	25640 Portico	\$272,000
Novi	25642 Portico	\$235,000
Novi	41811 Quince	\$260,000
Southfield	17048 Addison	\$169,000
Southfield	29528 Fairfax	\$139,000
Southfield	29852 Fairfax	\$145,000
Southfield	17305 Gateway	\$217,000
Southfield	17359 Gateway	\$169,000
Southfield	18515 Hilton	\$155,000
Southfield	23389 Hunters	\$160,000
Southfield	20415 Ledgestone	\$221,000
Southfield	16256 Mayfair	\$182,000
Southfield	23604 Mcallister	\$172,000
Southfield	23805 Oak Glen	\$165,000
Southfield	25169 Parsons	\$219,000
Southfield	24030 Philip	\$205,000
Southfield	24044 Pierce	\$205,000
Southfield	24750 Plumridge	\$139,000
Southfield	20499 Roseland	\$192,000
Southfield	22060 Rougewood	\$175,000
Southfield	19820 W 12 Mile	\$81,000
Southfield	29075 Wellington	\$146,000
Southfield	17530 Westland	\$215,000
Southfield	20455 Westover	\$105,000
Troy	2346 Alexander	\$198,000
Troy	1918 Axtell	\$132,000
Troy	1942 Axtell	\$134,000
Troy	233 Cloveridge	\$323,000
Troy	1914 Crimson	\$349,000
Troy	6929 Dakota	\$754,000
Troy	2265 Deer Path	\$615,000
Troy	685 E Maple	\$120,000
Troy	3859 Fadi	\$630,000
Troy	3930 Fadi	\$635,000
Troy	60 Florence	\$158,000
Troy	1449 Fountain	\$352,000
Troy	3943 Gatwick	\$495,000
Troy	3107 Heritage	\$285,000
Troy	2790 Mayfair	\$329,000
Troy	5804 Northfield	\$192,000
Troy	926 Norwich	\$210,000
Troy	4045 Parkstone	\$395,000
Troy	2755 Roundtree	\$140,000
Troy	5705 Whitfield	\$217,000
Troy	1005 Woodslee	\$133,000
West Bloomfield	2554 Alden	\$345,000
West Bloomfield	7494 Autumn Hill	\$543,000
West Bloomfield	1536 Bawtree	\$154,000
West Bloomfield	6338 Bentley	\$583,000
West Bloomfield	2160 Bordeaux	\$265,000
West Bloomfield	6555 Bridgewater	\$712,000
West Bloomfield	7499 Buckthorn	\$320,000
West Bloomfield	3741 Elder	\$368,000
West Bloomfield	4397 Foxpointe	\$225,000
West Bloomfield	3138 Gilbert Ridge	\$345,000
West Bloomfield	6707 Grassland	\$180,000
West Bloomfield	7380 Honeysuckle	\$327,000
West Bloomfield	2361 Horseshoe	\$413,000
West Bloomfield	2526 Ivanhoe	\$153,000
West Bloomfield	2575 Ivanhoe	\$140,000
West Bloomfield	3655 Knollview	\$163,000
West Bloomfield	4447 Laurel Club	\$165,000
West Bloomfield	6776 Locklin	\$258,000
West Bloomfield	3825 Lone Pine	\$115,000
West Bloomfield	2541 Middlebelt	\$282,000
West Bloomfield	6639 Minnow Pond	\$973,000
West Bloomfield	2953 Moon Lake	\$215,000
West Bloomfield	7109 N Wertybrook	\$215,000
West Bloomfield	1878 Oldtown	\$184,000
West Bloomfield	3774 Pine Lake Knoll	\$638,000
West Bloomfield	6930 Playfair	\$157,000
West Bloomfield	5533 Putnam	\$265,000
West Bloomfield	6575 Stonebridge	\$620,000
West Bloomfield	1591 Sugar Maple	\$430,000
West Bloomfield	7322 Village Square	\$565,000
West Bloomfield	5380 W Briarcliff Knoll	\$237,000
West Bloomfield	2468 Walce	\$167,000
West Bloomfield	7295 Willow Oak	\$265,000

APARTMENTS AVAILABLE

• Your Weekly Guide to Apartment Living •

CANTON

GREYBERRY APARTMENTS

Wayne - Westland Canton

2 Bedroom
920 Square Foot Apts
Washer & Dryer and
Window Treatments
In Every Unit

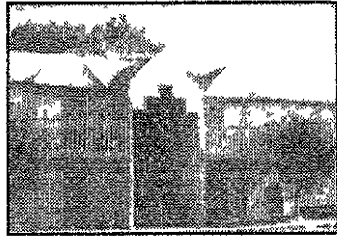

Now offering
**Rent Specials and
\$100 Security Deposit!**

Located N of Michigan Ave and East off Hannan Road

734-326-1530

CANTON

Make Your New Home At Beautiful Fordham Green Apartments

where you will experience exceptional service everyday!

1 & 2 Bedroom Apartments from \$705
2 & 3 Bedroom Townhouses from \$1000
Heat included AND 1 month free rent!
(on select homes)

5600 Fordham Circle, Canton, MI 48187
Call (734) 981-3700

For a Beautiful Living Experience

CLAWSON

Looking for the Purrfect Place?

Luxury Townhouse
447 N. ROCHESTER ROAD
2 bedroom,
1 1/2 bath, fireplace, air,
full basement with hookups.
We absolutely adore pets!
\$820

(248) 354-9119 Ext 206

CLAWSON

Partial to pets? So are we!

526-C 14 MILE ROAD

Luxurious 2 bedroom townhouse with fireplace
central air, hook ups for washer & dryer
\$780

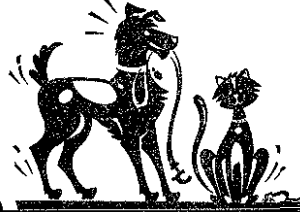

Please bring your pets -
we love them!

248-354-9119 x.206

DEARBORN HEIGHTS

Peace and Serenity Waiting
For You at

CARRIAGE PARK APARTMENTS

where you can expect outstanding
service in a park like setting



1 & 2 Bedroom Apartments from \$645
Heat included and 1 month **FREE RENT!**

27201 Canfield Dr #110 • Dearborn Heights, MI 48127
Call (313) 274-7277

For a beautiful living experience

DEARBORN HEIGHTS

Come Home to Beautiful

CARRIAGE HILL APARTMENTS

where you can relax & enjoy the mature
landscaping & the residential living
style of Dearborn Heights!



1 & 2 Bedroom Apartments from \$745
Heat included and **\$300 IN FREE RENT!**

26322 Westphal, Dearborn Heights, MI 48127
Call (313) 274-5141

For a beautiful living experience

DEARBORN HEIGHTS

Come Home to the
Serene and Peaceful

CHERRY HILL VILLAGE APARTMENTS

where you will be pampered & the exceptional
service and maintenance you can't find elsewhere!



1 & 2 Bedroom Apartments from \$595
Heat included and 1 MONTH **FREE RENT!**

238 Yorkshire #116 • Dearborn Heights, MI 48127
Call (313) 274-1933

For a Personalized Tour

FARMINGTON HILLS

Happiness Is...



Moving Into A Cozy,
1 Bedroom Apt,
With Reduced Rent
& Security Deposit

Carport & Water Included

Starting At \$545

CEDARBROOKE APARTMENTS
248-478-0322

FARMINGTON HILLS

Super location

STONERIDGE MANOR APARTMENTS

Enter off Freedom Road West of Orchard Lake South of Grand River

Deluxe 1 Bedroom Sub-Level from \$500/Mo.
Includes
Carpeting, vertical blinds, deluxe appliances

Monday Friday 9-5
Saturday & Sunday By Appointment

Rental Office: **248/478-1437**

FERNDALE

Royal Oak Towers

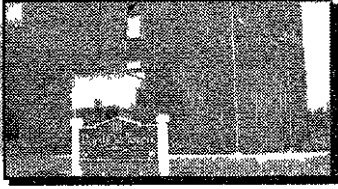

SPECIAL
1 bedroom from
\$450/mo.

55+ Senior Community
Includes Free Heat Water Electricity!

Affordable living spacious apt home w/balcony & many amenities. Enjoy many
activities fitness center walking paths beautiful grounds community room
solarium library & more Centrally located near shopping banks & bus route

Call or visit us today!

(248) 542-0882 • 20800 Wyoming

HOWELL

Pine Hill Apartments

Exceptional Value
Exceptional Amenities
Spa k rig Pool
Pets We come
Central a
Laundry fac
Extra storage
Private Balcon es patios
Co po a e Suites Ava ad e
Walk n closets
24-hr eme gency
ma ntenance

1 Month FREE Rent
& **FREE HEAT**
& **Reduced Security Deposit**
517-546-7660

307 Holly Drive, Howell MI 48843

TTY 800-989-1833

info@pinehillapartments.com

www.fourmidable.com

Professional y Managed By

INKSTER

Make Your New Home At Beautiful CHERRY HILL CLUB APARTMENTS

where you will experience
exceptional service everyday!

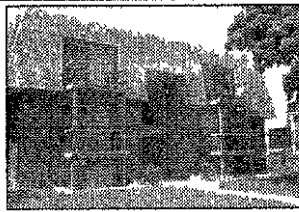

Studio, 1 & 2 Bedroom Apartments from \$495
Heat included and 1 month **FREE RENT!**

209 Cherry Hill Trail • Inkster, MI 48141
Call (734) 729-4550

For a beautiful living experience

KEEGO HARBOR

Bloomfield Lakes Apartment

Large Studio 1 & 2 bedroom Apartments
in small quiet complex next to park
West Bloomfield Schools

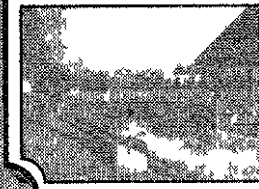

Rents from \$550
includes water

Furnished apartments also available

248-681-8309

LIVONIA

Come Home to Beautiful

DEERFIELD WOODS

where you can enjoy a resort
living style and leave the
maintenance to us!



1 & 2 Bedroom Apartments from \$675
with 1 month **FREE RENT!**

19559 Farmington Road • Livonia, MI 48152
Call (248) 476-6868

For a Beautiful Living Experience

MADISON HEIGHTS

Royal Madison Apartments

Clean
1 & 2 Bedroom
Apartments
\$565 - \$665

Small Apartment Community
Corner of 13 Mile and Campbell Centrally & conveniently
located to shopping 1 75 & 1 696 Pool and ample parking

\$0 Security Deposit
ONE MONTH FREE with approved 13 month lease
248-585-5077

www.royalmadisonapartments.com

NOVI

NOVI RIDGE

We C A T F R our residents!
24-hour fitness center
Conveniently located to shopping
dining & freeway access

1 Bedroom from \$655
2 Bedroom from \$699
2 Bedroom Townhouse from \$795
3 Bedroom Townhouse from \$895

25640 Chipmunk Trail • Novi, MI 48375
248-549-8200 • www.noviridge.com

Circle Rent Includes Apply Select Apartments

NOVI & WESTLAND



Fountain Park APARTMENTS

**UP TO \$2000 IN
FREE RENT!**

2 Locations • Washer/ Dryer • Private Entry

NOVI
On Grand River next to Main St
866-365-9239

WESTLAND
Newburgh S of Joy
866-365-9238

fountainparkapartments.com
When you lease expect it!

OAK PARK

Come Home to Beautiful OAK PARK MANOR

where you can enjoy a maintenance
free lifestyle while keeping the
privacy of home-style living!



2&3 Bedroom Townhomes from \$825
with 1 MONTH **FREE RENT!**

13600 Kenwood • Oak Park, MI 48237
Call (248) 541-8455

For a beautiful living experience

APARTMENTS AVAILABLE

• Your Weekly Guide to Apartment Living •

OXFORD
WELCOME HOME



- Free Heat
- Free Air Conditioning
- Extra Storage Area
- Emergency Call System
- Barrier Free Apartments
- Carpools Available
- Elegant Community Room
- On Site Laundry Facilities
- Social Events
- Close to Shopping
- On Site Management
- On Site Beauty Salon

For more information call (248) 628-7676 or stop by for a tour
Hope Senior Apartments • Age 62 or Better
 210 West Drahn Road • Oxford MI 48371
 TDD 1 800 649 3777 • lockwoodcompanies.com

PONTIAC
Stop, Look & Lease

1 & 2 Bedrooms
 Starting at \$599 to \$649
 \$99 Security Deposit
 December Rent **FREE!**
Based on 1 year lease

248-253-1777

1301 WOODLAKE LANE
 PONTIAC MI 48340
(OFF BALDWIN 1/4 MILE S OF GREAT LAKES CROSSING)

- Private Entrance
- Central Air
- Washer & Dryer Hook-ups

*INCOME RESTRICTIONS

REDFORD
Cozy Complex



1 Bedroom • \$585
 2 Bedroom, One Bath • \$655
1/2 Off 1st Month's Rent!

★ **Fill out application at time of 1st visit and we will waive the application fee!** ★

Includes water, C/A secured entrances, park like setting
 Near Joy/Inkster

(313) 937-3319

ROYAL OAK
ROOM FOR THE WHOLE FAMILY!



3535 Kent Court
 2 bedroom, 1 1/2 bath
 luxury townhouse
 with fireplace,
 air, basement
 with hookups.
\$320
 We Love Pets!
248-354-9119
 extension 206

ROYAL OAK
BRING YOUR PETS!



115 AMELIA

2 huge bedrooms lots of closets approximately 1550 sq ft + full basement 1 1/2 baths formal dining room fireplace central air hookups for washer & dryer Extra deep backyard Pets ARE welcome! \$1200/mo
 248 354 9119 Ext 206

ROYAL OAK



2205 STARR ROAD
 2 bedroom, 1 bath luxury townhouse with fireplace, air, full basement with hookups
 Nice backyard
 \$780
 We ♥ PETS!
CALL 248.354.9119 x206

ROYAL OAK
Luxury Townhomes



2700 Rochester Road
 3 bedroom 1 1/2 bath
 townhouse with fireplace
 air full basement
 with hookups and
 We Adore pets!
 \$1050
 (248) 354 9119 ext 206

SOUTHFIELD
We're BIG on Square Feet

1, 2 & 3 Bedroom
 Apartments & Town Homes
 From \$815

- Heat, water, carpet included • Pet Policy
- Night Gatekeeper • Heated Pool
- Private Balcony • Short Term Leases
- Close to Birmingham Shopping and Freeways

Country Corner
 30300 Southfield Road
Located on Southfield • Between 12 & 13 Mile Road
 248-647-6100
Academy Residential Manager

WATERFORD
Stop by and Check Out Our Fabulous FALL SPECIALS!

2 Months Free • \$99 Move In!

- Private Balcony/Patio • Carpools
- Central Air Conditioning • Dog & Cats Welcome
- Walk in Closets • Laundry Facilities • Clubhouse
- Sparkling Pool • Picnic Area with Grills
- Resident Functions

Heritage Park Apartments
248-673-2226
*Select Units Only

WAYNE
TAE KEUK VILLAGE

KOREAN AMERICAN COMMUNITY HOUSING SERVICES INC
 3712 WILLIAMS ST WAYNE, MI 48184
 Phone: 734-729-7920, 729-3432
 Fax 734-729-0938

Efficiency Units Available Right Now!!

- Section 8 apartments for the elderly and disabled
- Studio & One Bedroom
- Applicant must be either at least 62 years of age or disabled
- Emergency Medical Call System
- Rent includes Heat and Water

Professionally managed by Midwest Management, Inc.

WEST BLOOMFIELD
THORNBERRY APARTMENTS

COME HOME FOR THE HOLIDAYS

FEATURING
 West Bloomfield Location
 Luxurious Renovations
 Private entrances
 Private garages
 In home full-size washer/dryer
 24 hour fitness center
 Beautiful Community Room

Call for details
 (888) 206 4709

TTY (409) 969-1832
 5460 Bentley Road
 West Bloomfield, MI 48322
Let us show you why you should move to Thornberry.

Professionally Managed By
FOURMABLE

WESTLAND
Westland Estates

“WOW”
\$99 total move-in!

No fine print in this ad!
 Heat/Water included • \$25.00 Application Fee
 New Resident's Only

1 bedroom 700 sq ft from \$565
 2 bedroom 900 sq ft from \$655
 2 bedroom plus 1000 sq ft from \$680

734-722-4700

WESTLAND
RIDGEWOOD APARTMENT HOMES

6470 YALE AVE.
 WESTLAND MI 48185

We Will Pay For Your Move!!!!

Studios Available
 Starting at just
\$499 a Month

MOVE IN TODAY AND WE WILL PAY FOR THE MOVERS WHILE YOU ENJOY A MASSAGE OR A NIGHT OUT ON US!!!

Private Entrance
 On-Site Laundry Facility
 Single Story Design
 Satisfaction Guarantee
 Service Request Guarantee
 Large Pets Welcome

734-728-6969
 Tues-Fri 10 am 5 pm • Sat 9 am 1 pm

WESTLAND
WESTLAND PARK APARTMENTS



\$199 moves you in
(1st Month \$100 + Security Deposit \$99)
2nd Month FREE RENT

2 Bedroom 1 1/2 bath 936 sq ft \$650
 1 Bedroom 728 sq ft \$575
 Heat/Water included

Very clean apartments • Excellent maintenance • Central air Intercom • Appliances include dishwasher and more • No pets
(734) 729-6636
(New residents only with approved credit 1 year lease)

WESTLAND
HAMPTON COURT APARTMENTS

Come Home to the Beautifully Maintained



where you will have all the amenities you desire!!

1 & 2 Bedroom Apartments from \$665
Hurry in and get 1 month FREE RENT!
(on select apartments)

5800 N Christine, Westland, MI 48185
 Call (734) 729-4020
For a Personalized Tour

WESTLAND
GREAT RATE! \$450/MONTH



★ **Fill out application at time of 1st visit and we will waive the application fee!** ★

NEWBURGH COLONIAL APARTMENTS

1 bedroom Michigan Ave/Newburgh area Private entrance walk in closet air conditioning ample parking onsite laundry
CALL 734-721-6699

WESTLAND
WE WILL PAY FOR YOUR MOVE!!!!

RIDGEWOOD APARTMENT HOMES

6470 Yale Ave • Westland MI 48185

- Private Entrance
- On Site Laundry Facility
- Single Story Design
- Satisfaction Guarantee
- Service Request Guarantee
- Large Pets Welcome

Studios
 One Bedroom And Two Bedroom Apartment Homes Available

MOVE IN TODAY AND WE WILL PAY FOR THE MOVERS WHILE YOU ENJOY A MASSAGE OR A NIGHT OUT ON US!!!

Starting At Just
\$499 A Month

CALL TODAY!! 734-728-6969
 Office Hours Tues Fr 10 5 Sat 9 1
 equityapartments.com

WOODHAVEN

Nestled in a beautiful country setting at
SOUTHPOINTE SQUARE APARTMENTS
Here you can have the convenient location & all the amenities!



1 & 2 Bedroom Apartments from \$575
 Heat included with 1 month free rent!

22520 West Road • Woodhaven, MI 48183
 Call (734) 675-3844
For a Personalized Visit



Preview Hundreds of SUNDAY OPEN HOUSES
Throughout the Week at
www.Century21Town-Country.com

OPEN HOUSES
 Search for this week's
 Open Houses **GO**

■ Printable Feature Pages ■ Color Photos, Multiple Views ■ Directions and More

Take Your Search for a New Home to the Next Level.

 NOVI Spacious Condo This great 2 bedroom 2 bath unit overlooking protected wetlands. Great room w/bath ceiling gas fireplace master bedroom w/private bath and jetted tub. All appliances. 2 car attached garage & in unit laundry. (E09CAR) 734 455 5600 \$239,900	 WESTLAND Great Location 2 bedroom 1.5 bath condo w/Livonia school. Close to shopping & dining. Neutral decor LR w/natural flrptic to DR. Doorwall to private deck kitchen appliances & washer & dryer included. 2 WIC basement & att gar. (E83PRI) 734 455 5600 \$139,000	 NORTHVILLE TWP Spacious Colonial On beautiful interior lot in Crestwood Manor. Everything from hwd 2 story foyer w/winding staircase to full professionally fin bsmt. Formal DR FR w/fireplace den w/bay w/ndow mstr ste w/WIC's & Jacuzzi + att gar. (E10RDL) 734 455-5600 \$684,000	 NORTHVILLE Stately Colonial 4 BR 3.5 BA home on approx 2.4 acres. Formal DR FR master suite w/frpc & balcony. 2nd flr laundry lovely kitchen w/white cabinets, HWF. Conan counters. 2nd BR has private BA plus Jack & Jill bath for 3 & 4th BR. (E01SEV) 248-349-5600 \$714,900	 NORTHVILLE Walking Distance To Town Contemporary condo w/many upgrades. Hardwood floors heated floor in master bath. Large WIC in LL. W/O. Two large bedrooms. 2 car attached garage on wooded setting. All appls. Large deck off drng room. (E00MOU) 248-349 5600 \$320,500
 LIVONIA This Is The One! 3 bedroom 2 bath ranch located on double lot w/privacy fence for entire backyard. Open floor plan updated kitchen & bath. awesome finished basement w/bath & 2+ car gar. Newer shingles windows & drwf. (E68BUT) 734 455 5600 \$207,900	 LIVONIA Private Setting Ranch pool many updates! Roof (tear off) newer windows w/marble sill s d ng gutters and driveway. Spacious kitchen shed LL with gas fireplace. 2 car attached garage and updated baths. (E69MAY) 734 455-5600 \$204,000	 WESTLAND Meticulously Maintained Condo Cathedral ceilings 1st floor master suite w/WIC & bath, large kitchen w/eat in area. Large 2 bedrooms w/full bath 1st floor laundry finished basement large deck 2 car attached garage & ready to move into. (E23DAN) 734-455-5600 \$189,900	 REDFORD Nice Size Corner Lot 4 bedrooms new windows gutters & glass block in cedar paneled LL since 2004. Hardwood under carpet on 1st floor. Entire home repainted in 05. Partially finished LL. 2 car garage w/extra storage next to it. (E02WOR) 248 349-5600 \$135,000	 WEST BLOOMFIELD Designer Perfect! House beautiful on a wooded cul de sac! Maple cabinets granite and hardwood in this cooks delight kitchen. Grand master suite w/glamour bath. Jack and Jill guest suite private backyard and 3 car garage. (E43CHE) 248-349-5600 \$699,900
 DETROIT Lovely Home This 3 bedroom bungalow offers newer windows steel entry doors oak cabinets in kitchen basement and a home warranty is included. This home is ready for you. (E35LON) 734-455 5600 \$64,000	 PLYMOUTH 5 Star Condo Amazing 3 bedroom 3.5 bath townhouse w/2 car attached garage. Fin shed LL walkout library 2 fr areas hardwood floors. 1st floor overlooking G&E. All appls gated courtyard w/brick pavers and much more. (E41BEA) 734 455 5600 \$429,700	 CANTON Freedom From The City Updated 3 bedroom custom brick ranch on approx 1 acre. Open floor plan great room sizes huge finished basement fireplace in living room and heated workshop in 2 car garage. (E88DIO) 734-455-5600 \$249,900	 REDFORD Cozy Comfortable Home Fall in love with this home. Newer windows furn/AC. Updated kitchen w/coramic flrs. Lg owner suite. Freshly painted w/ hardwood flrs. Two car gar. Close to schools shopping & x ways. Maintenance free brick exterior. (E27WIN) 248-349-5600 \$134,900	 CANTON Ranch End Unit Great location. Newer windows carpet neutral throughout. Spacious living room children's play area. Plymouth Canton schools. Why pay rent when you can own. A must see. (E38DRC) 248-349-5600 \$94,900
 VAN BUREN Updated Brick Ranch 3 bedroom 2 bath w/in partially finished basement fenced yard backing to open park like area. Updated kitchen w/Pergo floor newer bathroom sink glass block windows newer roof electric. Walkside windows C/A. (E34JAC) 734-455 5600 \$159,900	 LIVONIA Enjoy The Tranquility Of sitting around your inground pool or in the Florida room on hot summer days + lovely family room w/cozy fireplace for cool winter night. All this in this 3 bedroom 2 bath ranch w/in bsmt & 2 car att gar. (E30PER) 734 455-5600 \$209,900	 MILFORD Cul-De-Sac 3 bedroom 2.5 bath colonial backs up to nature preserve. Custom interior painting shows like a model. Exterior roofed and painted in summer of 05. Closest organizers in all bedrooms. A must see! (E51DOR) 734 455 5600 \$299,900	 GARDEN CITY Tree-Lined Streets! 3 BR ranch Lg LR w/Andersen bay window. Refaced w/oak cab doors pull out B I dishwasher & stove incl. Cozy FR w/Andersen d wall to patio. 90% plus furnace C/A. Heated 2.5 car gar w/paner 1 yr warr. (E37BRO) 248 349 5600 \$139,900	 LIVONIA Updated Ranch Convenient location 3 bedroom 1 bath ranch with lots of updates including roof kitchen crown moldings hardwood floors LR & FR 2 car garage. Livonia schools one year home warranty. (E05PAD) 248 349-5600 \$159,900
 PLYMOUTH Walk to Downtown This spacious open floor plan offers easy to clean laminated wood flooring in kitchen foyer and high traffic areas. Freshly painted with neutral colors. 1/2 Added room in partially finished basement. (E19ANN) 734 455 5600 \$159,900	 WESTLAND A Real Dream House Home offers 3 bedrooms w/gorgeous basement w/summer kitchen nicer than you can imagine. It's only outdone by the main floor that's wonderful! Updated kitchen A/C turn roof windows and drive. (E39GIL) 734 455-5600 \$168,900	 PLYMOUTH Gorgeous Colonial This spacious 4 bedroom 2.5 bath home has it all from formal dining room gas fireplace in family room large eat in kitchen w/chostry cabinets & granite counters. 3 car attached garage master ste w/dressing area more. (E60WIL) 734 455-5600 \$417,900	 LIVONIA Popular Coventry Gardens 4 bedroom 2 bath cape cod. Priced for an immediate sale. This home has plenty of room to enlarge or keep things as they are and enjoy this great home. A great opportunity. (E30EDI) 248 349-5600 \$209,900	 SOUTH LYON Classic Custom Cape Cod Two toned cherry cabinets granite counters upgraded trim & molding. 1/2 two story BR w/large stone faced fireplace & custom mantle. 4 car garage insulated & fin. Park like yard w/mature trees. 27 hole golf course. (E60POI) 248-349-5600 \$659,900
 PLYMOUTH Immaculate Colonial 4 bedroom 2.5 bath home w/newer kitchen w/all built in appliances master suite w/renovated master bath new furnace & HWH 05 FR w/gas fireplace finished basement & 2 car attached garage. Prof landscp. (E40PAL) 734 455 5600 \$274,900	 LIVONIA Nestled Deep In The Subl This spacious home provides a tranquil setting with n walk n distance of school's. Updated garage door kitchen bath w/ furnace A/C roof w/ndows and more in this 3 bedroom 1.5 bath brick ranch. (E83HEE) 734 455 5600 \$211,900	 FARMINGTON Close To Town One story unit that has been newly decorated in 2005. Refrigerator and flat top range 2005. Carpeting and excellent landscaping. Great location close to schools shopping and expressways. (E53KIN) 248-349-5600 \$75,900	 DEARBORN HGTS Just Pack Your Bagel! This 3 bedroom brick ranch home is a move in ready. Updated carpet paint electrical and much more. Super location. Garage fenced yard appliances and one year home warranty included. Du ck occupancy better hurry! (E79MCK) 248 349-5600 \$109,900	 WEST BLOOMFIELD Fabulous Walkout Bring your fustiest buyer to this elegant colonial. Maple cabinets/kitchen granite in all baths. 2 story family room w/wooded view. Newer deck and brick pavers. 3 car garage. Grand master suite. Freshly painted. (E01PEM) 248-349 5600 \$649,900
 REDFORD Buyers Require A 10+ This is the one! Stunning 3 bedroom 1.5 bath brick ranch with South Redford schools. Sensational updated kitchen & main bath. Beautiful hardwood floors awesome finished basement + all appls stay & garage. (E35WES) 734 455-5600 \$179,500	 CANTON Look No Further! Spacious 4 bdrm 2.5 bath colonial w/2 story foyer fin bsmt. 2 car att gar. n dwd flrs 1/2 kit. LR FR w/frpc. 2nd flr laundry extra high ceilings on FR. Open floor plan from kitchen to family room. A rea must see!! (E96FEN) 734 455 5600 \$359,000	 DEARBORN Remarkable Home 4 bedroom 2 bath brick tudor w/2 full baths. prof fin bsmt. 2.5 car garage newer furnace 00 newer roof. 01 excellent landscaping. Great location close to schools shopping and expressways. (E18KEN) 248-349-5600 \$224,900	 SOUTHFIELD Move In Condition Clean bright and spacious 3 bedroom ranch with updated windows shingles and exterior doors. Spacious family room HDU. 05 Appliances included. Home warranty also included. (E97VEE) 248 349-5600 \$109,750	 LINCOLN PARK Great Area 3 bedroom 2 bath bungalow w/full basement oversized 2.5 car garage. Florida room deck large covered country porch newer roof furnace & A/C all nestled in a quiet serene neighborhood in des table area. (E04LEB) 248-349-5600 \$119,000
 TAYLOR Make It Your Own The charming 3 bedroom 2 bath ranch home has gorgeous rear yard with 1/2 moon BBQ grill. Newer furnace C/A & roof. Open floor plan w/fireplace & hwd flrs. Used as residential but zoned commercial. (E48GOD) 734 455 5600 \$239,000	 FARMINGTON HILLS Fantastic Cape Cod Freshly painted! Newer hardwood flooring in foyer hall and formal DR. GR w/natural brick flrpic vaulted ceiling to lib/FR and formal DR. Kit w/loads of counters. Fin bsmt w/rec room play room and cedar closet. (E26BRI) 734-455 5600 \$299,500	 REDFORD My First Home Great brick ranch with many updates throughout. Refinished hardwood floors newer windows and some painting. Finished basement private fenced yard and one year home warranty included. (E23FIV) 248-349-5600 \$116,000	 NOVI Super Condo Exquisite! This one won't last! Impress ve upgrades. Ground level 1 bedroom with wheelchair access. Extra large bath. Neutral decor freshly painted. View of woods. Shows like a model. Access to Walked Lake. (E55SLA) 248 349-5600 \$85,500	 CANTON One Of 'Sunflower's' Finest Feels like nature preserve. Backs to Fellows Creek. Lg MBR. Prof designed brick paver entry. Leadad glass window above entry door. Fin bsmt & storage. Prem lot. Oversized kit w/island. Covered screened porch off kit. (E99MOR) 248-349 5600 \$353,000
 WESTLAND Terrific Home! This 3 bedroom 1.5 bath home features attached garage basement hardwood floors in living room & bedrooms. family room w/natural flr replace awesome 2 tiered deck + updated oak kitchen bath & windows. (E40RED) 734-455 5600 \$169,000	 PLYMOUTH City of Plymouth Put your money into this great opportunity 3 bedroom 1 bath 1634 built home. Restore it to its original beauty and get your cash back very quick. Buy now. Home sold as is. Seller motivated. (E87ADA) 734 455 5600 \$170,000	 DEARBORN Welcoming Bungalow 3 BR brick bungalow near Fordson HS with hardwood floors 1/2 2nd floor bedroom with hugh walk in closet. Partially finished basement. All appliances included. Two car garage. In nicely fenced deep yard. (E49MAP) 248 349-5600 \$149,900	 NOVI Ranch Like New Accessible with no steps and 1 car att garage. Double lot w/privacy fence & above ground pool. Fresh paint & newer carpet. Jetted tub in master bath. 3 bedrooms 2 baths. Super location near x ways 12 Oaks & sch. (E30PAR) 248-349-5600 \$189,900	 SOUTH LYON Ranch Condo 55+ ranch condo in Centennial Farms w/clubhouse and beach on Crooked Lake. 2 bedrooms 2 baths newer carpet and paint. C/A. Florida room finished basement and covered porch. (E69CAR) 248-349-5600 \$125,000
 LIVONIA Beautiful Brick Ranch This 3 bedroom home is gorgeous inside & out. Updated from top to bottom with open floor plan. Partially finished basement 2 car garage and appliances. Awesome front yard and prof done patio. (E82ANT) 734 455 5600 \$189,000	 LIVONIA This Is The One! Updated in 2005 this 3 bedroom ranch offers newer kitchen bath windows hardwood floors interior and exterior doors vinyl s d ng so much more and priced to sell! (E05STF) 734 455 5600 \$134,900	 NORTHVILLE Golf Course Community 4 BR 4.5 BA col w/hwd flrs. Kid w/gran te counters & tumbled marble backsplash. Wow! LL w/built in media center/surround sound. Dramatic raised patio w/Pergola backs to 1st fairway. Crown molding. (E93RIV) 248 349-5600 \$659,000	 NOVI Spectacular Custom Home Beautifully detailed offers 4 spacious bedrooms 4.5 baths. Master suite features fireplace 2 WIC & granite bath. Gourmet kitchen w/Viking stove Sub Zero fr gr. Walkout LL w/heated floors sauna & full granite kitchen. (E55VAS) 248 349-5600 \$989,000	 LIVONIA Immaculate Condo 2 bedrooms 1.5 baths w/newer carpet updated kitchen molding & spacious open flr plan. Lg utility rm newer appls. Custom lighting. Carpet & screened in patio. Cust wndw trims. Clubhouse w/pool & gym. (E83UNI) 248-349 5600 \$139,900

Relocation Services 800-448-5817

CENDANT Mobility Broker Network

Birmingham 248-642-8100	Chesterfield Twp. 586-949-5590	Clarkston 248-620-7200	Clinton Twp. 586-286-6000	Commerce Twp. 248-383-1200	Fraser 586-294-3655	Grosse Pointe 313-896-5040	Northville 248-949-5600
Plymouth 734-455-5600	Rochester 248-652-6000	Royal Oak 248-280-4777	Shelby Twp. 586-731-8180	St. Clair Shores 586-778-8100	Sterling Heights 586-839-2600	Troy 248-524-1600	West Bloomfield 248-826-8800

Observer & Eccentric



Apartments

HOMETOWNLife.com

This Classification continues from Section F

Homes For Rent 4050

FERDALE 3 bdrm applances new C/A & furnace large back yard full size bsmt \$925 248 399 6974

FREE RENT! New homes for rent 1 month free and \$100 off FIRST 6 months
3 bdrm 2 bath \$889/mo All appliances and a/c included Pets Welcome 888 304 0078
College Park Estates 51074 Mott Rd Canton MI 48188 (Between Geddes & Mich Ave off Ridge Road) *on select homes Skyline/Clayton Retailer

Garden City Very clean 3 bedroom bungalow No pets Frst last & security \$850/mo + utilities 734 954 0554

GARDEN CITY Newly remodeled 2 bdrm home 1 car garage \$850/mo (313) 350 5227

GARDEN CITY LIVONIA Both are 3 bdrm bsmt garage \$995 Sec 8 okay Dec Free! lease option 734 487 7177

GARDEN CITY 139 BRANDT 4 bedroom 2 bath family room with fireplace C/A appliances microwave shed fenced granite throughout Available now
Reduced \$795/mo Showing Wed & Sun @ 4 00 313 920 5966/248 593 0064

INKSTER 3 4 bdrm 1 5 baths garage bsmt c/a Wayne/Westland schools \$975/mo 734 461 6113

INKSTER Remodeled 3 bdrm brick ranch 2 car garage Avail now option to buy avail \$600 248 788 1823

Homes For Rent 4050

Livonia \$1 275 w/\$500 move in Beautiful ranch w/3 bdrm 1 5 baths Attached garage Hx/Joy area Mark Regal Agent Direct 734 718 6176

LIVONIA 2 or 3 bdrm 2 bath home Middlebelt & Plymouth Rd Natural fireplace applances Starting at \$800 (734) 207 5123

LIVONIA Updated 3 bdrm ranch 1 bath 2 car attached garage fenced yard \$985/mo 734 420 5154

LIVONIA 3 bdrm 2 bath brick ranch Fireplace Wood floors all appliances FL room \$1200 313 999 4719

LIVONIA 1200 sq ft 3 bdrm 2 bath Newly emodeled Very clean All appliances \$1150/mo incl water OPEN HOUSE SUN noon 4pm 34299 Wadsworth St 48150 734 716 1918

LIVONIA 2 Bdrm 2 car garage \$825/mo plus \$1000 sec deposit Avail immediately Please call (734) 395 2131

When seeking out the best deal check out the Observer & Eccentric Classifieds 1 800 579 7355

LIVONIA 2 bdrm carpet appliances garage no pets option to buy \$725/mo + security (248) 685 8138

LIVONIA 3 bdrm bungalow All appliances air fenced Pets OK 9111 Hugh \$995+ sec 313 779 8506

LIVONIA 3 bdrm ranch garage freshly remodeled Fenced Option to buy on LC \$1000/mo 313 805 5309

LIVONIA 3 bdrm brick ranch 2 bath Livonia schools lg garage hardwood \$1180/mo avail Jan 15 810 923 9057

LIVONIA 3 bdrm carpeted fenced garage w/ walk up storage \$1050/mo + security 248 684 4398 248 259 1556

Homes For Rent 4050

NOVI 24018 LYNWOOD 3 br Ranch 1 5 bath 2 Car 1800 sq ft \$1 290/mo (248) 760 3373

OAK PARK Cute & remodeled 2 bdrm ranch immediate occupancy Option to buy avail \$350 248 788 1823

OAK PARK Gorgeous 2 bdrm 2 bath 2 car Finished bsmt \$1100/mo Ferndale Schools 248 217 2077

PINCKNEY on 10 acres 3 bdrm 2 bath home!! 5320 Patterson Lk Rd 1600+ sq ft pets ok basement avail NOW \$1075 760 598 6000

PLYMOUTH 3 bdrm Colonial 1 1/2 bath finished bsmt 2 car garage natural fireplace with many updates \$1450/mo Call for appt 734 812 1743

PLYMOUTH 5 bdrm 4 bath 2500 sq ft Finished bsmt 2 car garage \$2000/mo + security 734 788 1642

PLYMOUTH Completely updated 1930 2 bdrm bsmt garage CA gas FP deck & garage \$1100 + security Georgious! 734 576 0894

Redford 2 bdrm ranch base ment garage \$700 mo 19435 Po niana 7/inkster 248 476 6498

REDFORD Inkster/ School draft 2 bdrm bsmt garage Fenced appt \$775 mo + security 248 969 2624

REDFORD Very nice very clean 3 bdrm 1 5 bath ranch Joy Rd & Beach Daily garage lg bsmt fenced yard All pets welcome \$997 + security 734 429 2111 leave message

REDFORD (South) 3 bdrm bungalow 1250 sq ft new bath & kitchen appliances fshsd bsmt new a/c & furnace garage No Section 8 \$900/mo 248 872 6706

RENTERS Dreaming of home ownership? Call me for a list of affordable homes in your area. Sue @ The Michigan Group 810 844 2335

Homes For Rent 4050

ROCHESTER HILLS S Boulevard & Livonia area 3 Bdrm 1 5 bath \$900/mo (313) 824 0543

ROYAL OAK Downtown Charming! Wow! The best location and a sweet house just 2 blocks from downtown 1 3 bdrm 1 5 bath 2 car garage 1600sq ft Never been a rental before! Flexible lease terms \$1300 1600 Call Jeff (Agent) (248) 376 1513

SOUTHFIELD 2 Bdrm 1 5 bath brick ranch could be 0 down \$675/mo Call Mish 734 521 0194

SOUTHFIELD 3 bdrm 1 5 bath ranch Newly refurbished 2 car garage large lot Telegraph & 9 Mile \$1200 mo 248 722 5577

SOUTHFIELD 3 Bedrooms 2 baths 2 garage Central air Private 2 5+ acres wooded on Rouge/ravine walkout/rec room new furnace washer/dryer appliances deck No water bills! No smoking please Immediate Occupancy! Millers Leasing and Property Development \$1900 313 345 9950

SOUTHFIELD 8 Mile & Inkster 3 bdrm 2 bath upgraded kitchen lg deck \$950/mo + 1/2 sec dep 248 225 2737

SOUTHFIELD Very nice 3 bdrm brick ranch 2 car garage Section 8 welcome \$1200 248 914 0819 or 0707

CLASSIFIEDS WORK! 1-800-579-7355

Homes For Rent 4050

TROY 4 bed 2 5 bath 2 car garage almost new Full bsmt deck Troy Schools 2100 sq ft \$1900 248 641 7928 248 942 9218

WAYNE 3 Bdrm bsmt garage and appliances Fenced yard \$900/mo + security (734) 326 2622

WEST BLOOMFIELD 4467 APPLE VALLEY Newly remodeled 2700 sq ft 4 bdrm 2 5 bath family room fireplace appliances deck C/A 313 920 5666 248 593 0064
REDUCED TO \$1995/mo

WEST BLOOMFIELD 3 bdrm ranch 2 bath fireplace c/a garage fenced beach place leges \$1085 248 478 0213

WEST BLOOMFIELD 5 bdrms 3 5 bath quad level Remodeled 2 5 car garage Maple & Orchard Lake \$2150 immed ate Occup 248 577 5725

WESTLAND 2 & 3 Bdrm dup lexes (Vencly/Palmer) clean new carpet & paint fenced 2 Bdrm \$625 mo 3 Bdrm \$700 mo Avail 313 418 9905

WESTLAND 2 Bdrm 1 bath c/a updated kitchen stove fridge dishwasher \$650/mo \$1 000 sec (734) 891 1571

WESTLAND 3 Bdrm w/hot tub could be 0 down \$775/mo Ask about our 3 month special Call Jenn fer 734 521 0194

WESTLAND 3/1 5 brick ranch Bsmt Carport No pets \$950 + security 734 576 0894

WESTLAND Fairfield Glade Sub Deluxe 3 bdrm 2 5 bath luxury home \$1450/mo + sec Also will rent with option to buy (248) 344 2120

WESTLAND Newly renovated 2 bdrm 1 5 bath next to schools fenced n backyard \$675/mo Sect 8 welcomed! Must See (734) 397 7283/ 734 644 4484

Homes For Rent 4050

WESTLAND BAD CREDIT DK! Rent to Own 38249 N Jean 3 bdrm bsmt 2 5 car Appliances \$1200/mo 734 306 2006

WESTLAND MUST SEE! 3 bdrm 1 bath brick ranch \$1200/mo 1st & last mo rent + \$750 security 734 341 1010

YPSILANTI 4 Bdrm 2 bath Pulte home built 2003 deck sprinkler system & appliances \$1695/mo (734) 616 2492

Lakefront/Waterfront Homes/Rental 4060

SOUTH LYON 3 br 2 bath brick ranch canal front to chair of lakes 2 car garage c/a \$1 600/mo \$1 000 security deposit 248 640 7531

Mobile Home Rentals 4070

CANTON We have new homes for rent Pets welcome Call Sandy at Sun Homes for deta is at 888 304 8941 Skyline/Clayton Retailer

REFURBISHED MOBILE HOMES FOR SALE OR RENT Small down payment & seller finance Small family oriented community Free month's rent to qualified applicants ask for details Riverview Mobile Home Park 734 721 7215

Southern Rentals 4090

ENGLEWOOD FLA Waterfront 3 bdrm 2 bath brand new condo \$2800/mo discount for 3 mo rental Security dep & references 248 379 4501

Living Quarters To Share 4120

PLYMOUTH Private bdrm and share kitchen/bath or studio w/ private kitchen/ bath/ bed \$350 \$550 734 646 1135

PLYMOUTH Gorgeous home \$420/mo includes utilities Storage avail Lots of amenities 734 262 5500 anytime

WESTLAND 3 bdrm 1 5 bath condo to share utilities incl \$400/mo + \$400 sec (352) 430 8506 leave mess

Rooms For Rent 4140

Highland Lakes Condo Northville Mature professional Like cats Kitchen/laun dry privileges 248 349 7334

NORTHVILLE or PLYMOUTH Downtown 1st week with full deposit Furn shed sleeping rooms Secure by deposit \$1695/mo (734) 616 2492

PLYMOUTH Sheldon & Ann Arbor Rd \$400 Kitchen using working person Call 313 613 3463 Home 734 416 1285

REDFORD Mature male non dr nker digital TV \$100/week 248 477 5726 248 666 2152

TRIPLE A DELUXE MOTEL A/C Jacuzzi in rooms ma d service HBO Low da ly/wkly rates Tel 96 Inn 313 535 4100 Royal Inn 248 544 1575 Fairlane 248 347 9999 Relax Inn 734 535 9990

It's All About Results Observer & Eccentric 1-800-579-SELL

Office/Retail Space For Rent/Lease 4220

FARMINGTON HILLS Retail Space Great Exposure 1300 4480 sq ft Excellent Rates **CERTIFIED REALTY INC 248 471 7100**

GARDEN CITY Near Garden City Hospital Medical/Dental Office 1100 sq ft \$1200 (734) 427 6590

NOVI OFFICE SUITE 440 sq ft 9 Mile & Novi Road area Utilities incl \$475/mo 248 349 0260 ext 202

REDFORD TWP Office Suites 2 or 3 room suites Beautifully redecorated Great Rates including utilities **CERTIFIED REALTY INC (248) 471 7100**

Commercial/Industrial For Rent/Lease 4230

CANTON RETAIL 1500 3000 SQ FT retail space in new building in Canton On Michigan Ave between Haggerty & Lilley \$18/sq ft Bela Sipos 734 747 7888 eves 734 669 5813 Reinhart Commercial #2412466

LIVONIA COMMERCIAL/ OFFICE SPACE AVAILABLE Incl kitchen garage storage area & 2 3 offices Call Tom at 248 737 3707

Lease/Option To Buy 4580

CANTON 3 bedroom 2 bath 2 car attached Gorgeous! Won't last long \$1995/\$750 negotiable 248 921 2432

NORTHVILLE Rent to own \$900/mo 2 Bdrm 1 bath condo 1 car attached garage Pool Dave 248 910 1077

Observer & Eccentric



Employment

HOMETOWNLife.com

5000's Jobs and Careers

5000 Help Wanted-General
5010 Help Wanted-Computer Info Systems
5020 Help Wanted-Office Clerical
5030 Help Wanted-Engineering
5040 Help Wanted-Dental
5060 Help Wanted-Medical
5080 Help Wanted-Food/Beverage
5100 Help Wanted-Health & Fitness
5110 Help Wanted-Professional
5120 Help Wanted-Sales
5200 Help Wanted-Part Time
5240 Help Wanted-Domestic
5260 Help Wanted-Couples

5300 Help Wanted-Entertainment
5320 Students
5340 Jobs Wanted
5360 Female/Male
5380 Childcare Services
5390 Licensed
5370 Childcare/Babysitting Services
5380 Childcare Needed
5400 Elderly Care & Assistance
5420 Nursing Care & Homes
5500 Summer Camps
5600 Education/Instructor
5620 Business & Professional Services
5700 Attorneys/Legal Counseling
5720 Help Wanted Tax Services
5740 Business Opportunities
5770 Tutoring

1-800-579-SELL

Help Wanted-General 5000

APPLIANCE INSTALLER Kitchen Appliance Installation company looking for fulltime dependable hardworking person with a good driving record to assist with appliance installation. Exp helpful but willing to train. Fax resume to 248 642 3192

ASSEMBLER S Home based position \$4 \$9 hou average great! keasassembly.com

ACCOUNTANT Novi area CPA firm seeking full time accountant CPA preferred opportunity for flexible schedule 2 5 years experience Send resume to Attn S W 41800 W Eleven M e Rd Sute 101 Nov MI 48375

ADMINISTRATOR

SWIFT TRANSPORTATION Now Hiring **SAFETY COMPLIANCE ASSISTANT** We'll Ensure That All Driver Qualification Files Are Accurate & Complete Swift Offers A Competitive Compensation Package Including Full Benefits After 30 Days 401k & Stock Purchase Plan E mail or Fax Resume To Alan Tyson@swifttrans.com Fax 734 753 2350 Contact Alan Tyson

Help Wanted-General 5000

Auto Service Appointment Coordinator needed for growing import dealer Full time position experience preferred great pay benefit and working environment Contact Brian Stroik Service Manager Dwyer & Sons Imports (248) 624 0400 Fax (248) 926 3471

AUTO TECHNICIANS CRESTWOOD DODGE (734) 421-5700

Beverage Technician Service equipment co seeks person with mechanical/technic an ability diagnostic skills & good driving record Drug test neg & ability to travel locally Seif motivated reliable & great customer service skills Competitive pay benefit & company vehicle Complete application at www.keenbeverage.com and fax or email with resume to (734) 729 7149 or hire@kensbeverage.com Or stop in at Ken's Beverage 3970 2nd St Wayne MI 48184

BOWLING HEAD MECHANIC ON AMF 8270 or will consider good B Mechanic Call (734) 664 7973

hometownlife.com

Help Wanted-General 5000

Cabler Voice & Data \$8 \$12/hr Excellent benefits Utracom Inc 25860 Lahser Rd Southfield MI 48034 Phone (248) 350 2020 Fax (248) 350 9066

CAREGIVER/HOME HEALTH For n home special needs care Part/Full time Many cases throughout Macomb & Oakland Counties Call 248 856 0004

CARPENTER LEAD/ PROJECT MANAGER For a well established Plymouth remodeling company Must have remodeling exp own tools & truck Exp pay & benefit 734 453 1478

CARPET CLEANERS/ RESTORATION TECHS Needed for 24 hr emergency restorat on company Exp in water damage a plus Full time with benefits Must be reliable good driv ng record EOE 313 277 0200 248 895 3000

CENTERLESS GRINDER OPERATOR With 3 5 years exp Exc pay 734 464 6866 Leave message

CLASSIFIEDS WORK! 1-800-579-7355

Help Wanted-General 5000

Child Care Christian Center needs Teacher for 2 yr old class Exp necessary & minimum CDA Also need Afternoon Aides (734) 699 5000

CHILD CARE TRANSITIONAL PRE SCHOOL HEAD TEACHER Learn While You Earn The Learning Tree offers employees an Education reimbursement program on site training along with 401K Retirement Plan Medical/Dental Benefits Paid Vacation/Hol days and Persona Days Raise Reviews 3 Yearly Bonus Program Call 734 261 1951 or apply in person

CHILD CARE ASSISTANTS Part time 20+ hours mostly afternoons for Plymouth Christian Learning Center Name 734 455 3196

CHILDCARE CENTER/CANTON Has positions for Full Time No experience necessary will train Call between 9AM 5PM (734) 416 1580

CHILDCARE HELPER Needed for Part Time Must be 18 Experience req Plymouth 734 459 9566

Help Wanted-General 5000

COMMERCIAL PROPERTY MANAGER Well established property management company looking for a full time experienced commercial property manager to oversee the management of a portfolio consisting of industrial office and retail properties Excellent opportunity offering long term stability and benefits Send resume ScottL@arbel.com

CONSTRUCTION & SERVICE TECHNICIAN With experience for Michigan's largest factory built home service company based in Novi Must have excellent customer relation skills & knowledge of home construction standards Adequate tools needed for completing repairs Benefits FAX resume to Service (248) 349 4519

CONSTRUCTION ESTIMATOR Industrial/Commercial General contractor seeks a person with 3 or more years exp in construction estimating Competitive wages good benefits and bonus program Please send resume to scott_nemecek@lasallinc.com

Help Wanted-General 5000

COMMUNITY OUTREACH MARKETER Luxury retirement community is seeking an EXPERIENCED outside sales consultant Require experience in outside sales to senior and medical related businesses Responsibilities include generating business referrals to retirement and assisted living communities in the Canton Plymouth Northville Novi and surrounding areas Must have a bachelor's degree be able to work some weekends have good computer skills and own a car We offer competitive wages excellent commissions along with medical and dental benefits EOE Please send resumes to DB at 734 844 8090

CONTROLLER Financial services organizations with multiple profit centers seeks Controller Fax resume & income requirements to (248) 487 0369

Call to place your ad at 1-800-579-SELL(7355)



WE MAKE IT EASY.

When Joe's Produce in Livonia needed a cashier, Donna Kuhn called us to place a help wanted ad.

Donna let us know about her results...

"We had a fantastic response from our ad, probably 75 people came in to apply and we had several phone calls (and the phone number wasn't even advertised!)"

DO YOU NEED HELP? CALL US TODAY!

Observer & Eccentric
NEWSPAPERS
CLASSIFIED ADVERTISING
1-800-579-7355

ENGINE TECHNICIANS
High Performance engine supplier has the following opportunities for highly motivated team players

Engine Assembly Technician -Marine Division
Individual will be responsible for the complete preparation and assembly of our Marine engines Candidate must have a minimum of 5 years experience in engine assembly Basic computer skills are also required

Entry Level Engine Technician
Individual will be responsible for engine tear-down record keeping cleaning and testing of components, and final inspection Candidates must have strong work ethic and good mechanical and computer skills

Company provides excellent salaries and benefits package

Please send resume with references to **Illmor Engineering, Inc.**
43939 Plymouth Oaks Blvd
Plymouth, MI 48170
(734) 456-3691 fax

TESTIMONIAL

"We consistently use only the Observer & Eccentric to look for new employees, because that's the only place to get results"

Novetsky A. Lukacs DDS P.C.

32905 W. 12 Mile Rd.
Suite 420
Farmington Hills
248-553-4740

For the opportunity to advertise on this page please call **Terry Randall (734) 953-2079** or email: careers@oe.homecomm.net

Observer & Eccentric



Employment

HOMETOWNlife.com

Help Wanted-General 5000

POLICY

All advertising published in the Observer and Eccentric Newspapers is subject to the conditions stated in the applicable rate card. Copies are available from the advertising department. Observer and Eccentric Newspapers reserve the right not to accept an advertiser's order. Observer and Eccentric Newspapers sales representatives have no authority to bind this newspaper and only publication of an advertisement shall constitute final acceptance of the advertiser's order. When more than one insertion of the same advertisement is ordered, no credit will be given unless notice of typographical or other errors is given in time for correction before the second insertion. Not responsible for omissions. Publisher's Notice: All real estate advertising in this newspaper is subject to the Federal Fair Housing Act of 1968 which states that it is illegal to advertise any preference, limitation or discrimination. This newspaper will not knowingly accept any advertising for real estate which is in violation of the law. Our readers are hereby informed that all dwellings advertised in this newspaper are available on an equal housing opportunity basis. (FR Doc. 724983 3 31 72) Classified ads may be placed according to the deadlines. Advertisers are responsible for reading their ads the first time it appears and reporting any errors immediately. The Observer and Eccentric Newspapers will not issue credit for errors in ads after THE FIRST INCORRECT INSERTION. Equal Housing Opportunity Statement: We are pledged to the letter and spirit of U.S. policy for the achievement of equal housing opportunity throughout the nation. We encourage and support an affirmative advertising and marketing program in which there are no barriers to obtaining housing because of race color religion or national origin. Equal Housing Opportunity slogan. Equal Housing Opportunity logo. Illustration of Publisher's Notice.

Help Wanted-General 5000

DENTAL ASSISTANT

32 hrs Progressive high tech Farmington Hills office (248) 474 2280

DIESEL MECHANICS

Truck dealership and Leasing co seek diesel mechanics for immediate hire. Openings in Livonia Dearborn and Warren. Good wages and benefits. 401k paid training 1st and 2nd shifts OT available ASE or State Certified preferred at least 3 5 years of experience. Must have own tools. Pay based on experience. Drug free workplace. EOE.

Fax 313 564 5661
Email: scurmer@trnctruck.com

DIRECT CARE day shift

Full time Cook position. Needed at 16 person group home in Western Wayne County. CMH trained necessary. Great wage & benefits. (734) 422 1020

Direct Care Positions

available working with people in their homes. Competitive pay & benefits. All shifts paid training. Great people mean ingful work. 734 728 4201

HAIR SALON PROFESSIONAL Stylists

Manicurist & Assistants. Looking for a positive change? Currently scheduling confidential interviews. Contact Heather 248-477-6000

HEATING REFRIGERATION ENGINEER

(Redford MI) Plan design install & service heating/refrigeration systems for newly constructed & existing buildings to assure that the proposed design conforms to building & safety codes. Analyze provide solutions to any mechanical malfunctions. Bachelor Degree or equivalent in Mechanical Engineering. Technology 40 hpw. Mail resume Liberty Total Comfort Systems 25550 Grand River Redford MI 48240

HOUSEKEEPERS

Part time for American House Senior Living in Northville. Call Judy 248 445 1480

HVAC SERVICE INSTALLER TECHNICIAN

Minimum 10 yrs exp NATE Certification required. Top pay w/full benefits. 1 800 409 7803

LANDSCAPE FOREMAN NEEDED

Must be experienced. Excellent wages. **Crimholt Nursery** 50145 Ford Rd Canton MI 48167 Phone (734) 495 1700 Fax (734) 495 1131

LAW ENFORCEMENT

Full time no exp Req'd We train. MF age 17 34 Good pay excellent benefits. Educational and travel opportunities. Call (734) 729 0450 AN ARMY OF ONE U.S. Army

LEASING AGENT

Full Time Westland Apts Full Benefits Included Leasing / Customer Service exp preferred. May work Saturdays. 734 425 0052

MAINTENANCE & PRO SHOP ATTENDANTS

Suburban Ice Farmington Hills is seeking qualified individuals for the positions of Maintenance & Pro Shop Attendants. Job responsibilities include building maintenance general cleaning ice resurfacing skate sharpening & customer service. Must be 18 yrs or older to apply. Contact Geoff Bennetts at (248) 888 1400

GENERAL HELP

Fall Cleanup Landscaping Snow Plowing MECHANIC 248 521 8818 or 248 489 5955 Ask for Mike

Help Wanted-General 5000

LOOK FOR MORE
Observer & Eccentric
JOB LISTINGS
AT
careerbuilder.com

GENERAL CONTRACTORS EXPEDITOR/ ADMINISTRATIVE ASSISTANT

Construction office exp help. Full must be computer literate. Good pay with benefits. Send resume to 5002 Dewitt Canton MI 48188 attn Human Resources. (No phone calls)

GENERAL LABORER

Part/full time Property Maintenance Co \$10/hr no bene. Must have reliable transportation. (248) 888 8400

HAIR SALON PROFESSIONAL Stylists

Manicurist & Assistants. Looking for a positive change? Currently scheduling confidential interviews. Contact Heather 248-477-6000

HAIR STYLISTS

Now hiring for Canton Plymouth S Livonia & Westland locations. Guarantee hourly rate. Please call Steve (734) 595-6003

HEATING REFRIGERATION ENGINEER

(Redford MI) Plan design install & service heating/refrigeration systems for newly constructed & existing buildings to assure that the proposed design conforms to building & safety codes. Analyze provide solutions to any mechanical malfunctions. Bachelor Degree or equivalent in Mechanical Engineering. Technology 40 hpw. Mail resume Liberty Total Comfort Systems 25550 Grand River Redford MI 48240

HOUSEKEEPERS

Part time for American House Senior Living in Northville. Call Judy 248 445 1480

HVAC SERVICE INSTALLER TECHNICIAN

Minimum 10 yrs exp NATE Certification required. Top pay w/full benefits. 1 800 409 7803

LANDSCAPE FOREMAN NEEDED

Must be experienced. Excellent wages. **Crimholt Nursery** 50145 Ford Rd Canton MI 48167 Phone (734) 495 1700 Fax (734) 495 1131

LAW ENFORCEMENT

Full time no exp Req'd We train. MF age 17 34 Good pay excellent benefits. Educational and travel opportunities. Call (734) 729 0450 AN ARMY OF ONE U.S. Army

LEASING AGENT

Full Time Westland Apts Full Benefits Included Leasing / Customer Service exp preferred. May work Saturdays. 734 425 0052

MAINTENANCE & PRO SHOP ATTENDANTS

Suburban Ice Farmington Hills is seeking qualified individuals for the positions of Maintenance & Pro Shop Attendants. Job responsibilities include building maintenance general cleaning ice resurfacing skate sharpening & customer service. Must be 18 yrs or older to apply. Contact Geoff Bennetts at (248) 888 1400

GENERAL HELP

Fall Cleanup Landscaping Snow Plowing MECHANIC 248 521 8818 or 248 489 5955 Ask for Mike

Help Wanted-General 5000

MAINTENANCE TECH & NIGHT SUPERVISOR

Apartment community looking for part time person includes Free Apartment & Wage Retirees welcome to apply. Apply at 29477 Cherry Hill Rd Inkster EEOC Equal Housing Opportunity

MANAGEMENT POSITION

For educational supplement service provider in Michigan. Must be willing to travel. Min Bachelors deg exp in business/ education preferred. Email resume/ salary req to mmccully@mercutoring.com

MECHANIC

Experience with gravel train and semis. Call Mon-Fri 8am-4pm (734) 455 4036

MECHANIC

Full time no exp Req'd We train. MF age 17 34 Good pay excellent benefits. Educational and travel opportunities. Call (734) 729 0450 AN ARMY OF ONE U.S. Army

MILL HAND

Must have Prototrack exp 55.5 hrs/wk Medical dental 401K OT daily Westland. Fax resume 734 595 0149 call 734 595 6400

MOLD MAKER

Minimum of 5 yrs exp. Fax (734) 422 9455 or email mbens@advance.mold.com

PARALEGAL

Farmington Hills Law firm seeks a College Student/ Graduate with a strong work ethic & a desire for learning and advancement for a Paralegal position. No prior experience necessary. Will train. Please email resume to MiComLaw@aol.com

PART TIME PRESCHOOL COORDINATOR SITE SUPERVISORS AND BABYSITTERS

Birmingham Family YMCA 400 E Lincoln Birmingham MI

Plumbing Service Co

Looking for passionate Journeyman Plumber with a desire to grow. (734) 525 5246

PUBLIC SAFETY SERVICE OFFICER/ DISPATCHER

Accepting applications for the position of Public Safety Service Officer. Salary \$32 312 per year. Written and Physical Agility testing will be conducted on Friday December 16 2005. Job description with complete qualifications will be available on the Canton Township website at www.cantonmi.org or may be viewed at the Canton Township Human Resources Division 1150 S Canton Center Rd Canton MI 48188. Applications may also be picked up at the Canton Administration Building Human Resources Division on the Canton Township website. A Canton Township application form must be completed in its entirety and on file in the Human Resources Division prior to 4 p.m. December 2 2005. Faxed or e-mailed applications will not be accepted. The Charter Township of Canton does not discriminate on the basis of race color national origin sex religion age or disability in employment or the provision of services. An Equal Opportunity Employer.

RESTORATION TECHS & CLEANING PEOPLE

For a growing 24 hr emergency restoration co Good wages Full time Benefits after 6 months. Must be reliable & have good driving record. Sunlight Restoration Service 27189 W Warren Dearborn Hts 1 800 574 2000 EOE

Help Wanted-General 5000

SALES OPPORTUNITY

Experience Preferred Advances & Commission. Send resume to mbilas@advantagefirst.us or Fax 313 537 3118 Phillip/Mike

SCREW MACHINE OPERATORS

With 3 5 years exp. Exc pay 734 464 6556. Leave message

SNOW PLOW DRIVERS EXP

With & without a plow truck. Need a valid driver's license. Please call Greg 734 453 1039

Snow Removal Co in Plymouth

seeks Laborers for snow blowing/shoveling & salting/sidewalks. Top pay. Extra pay for own transportation. Call Chad 734 453 5200

SNOW SHOVELERS/LABORERS

\$12 per hour paid daily. Call 248 676 0700

STILL SEARCHING?

For CareerMarketPlace on the front cover of the Employment section for more careers! Observer & Eccentric

TEACHER & TEACHERS ASSISTANT

The Childrens Hour Day Care. Now hiring. Call Mon-Fri before 6pm 734 459 9920

TECHNICIAN CRITTER CONTROL

Animal Damage Control Technician needed. Critter Control the nation's largest animal control firm is looking for individual with good customer service skills some sales experience a plus. Requires a good driving record comfortable working on ladders & roofs. Bonuses Call Debby or Ken 734 544 7171 or fax resume 734 326 2292

TELLER

Farmington Credit Union has an opening for a Full Time Teller. Hours are Monday-Friday (no Saturdays). Applicant must possess good math skills and ability to cross sell products and services. Previous teller or cash handling experience necessary. Competitive salary full benefits including health and dental insurance. Send resume to Vice President Member Service 22981 Farmington Rd Farmington MI 48336

Help Wanted-Office Clerical 5020

BUSINESS/IT MANAGER

Desire a college graduate to support technical & people areas. Prefer experience in computer application training & call center management. Programming experience a definite plus. Help manage a 24/7 national contact center in casual & cozy Plymouth MI. Handling incoming calls for wildlife control national franchise. Train franchisees in CRM & accounting software \$45 000 for the right professional person. Fax resume to (734) 453 6395 or email haps@crittercontrol.com

COMPUTER FIELD TECHNICIAN NEEDED

For corporate & residential computer service. Immediate opening. Must be experienced in all Microsoft Desktop & Server operating systems. Minimum 2 yrs exp in net working virus & spy ware removal. Active directory exchange server DNS VPN IP routing exp helpful. Salary company vehicle & benefits. Fax resume to (734) 468 0613

Help Wanted-Office Clerical 5020

ADMINISTRATIVE ASSISTANT

Small consulting firm is seeking an exp admin assistant. Responsibilities include coordinating meetings making travel arrangements managing schedules and corporate communication. Individual should have strong organizational skills and willingness to be part of a team. Must be well versed in Microsoft Word. Minimum of 2 years prior exp required. Salary commensurate with exp. Benefits avail. Send resume to 1000 S Woodward Ave Suite 105 23 Birmingham MI 48009

ADMINISTRATIVE/OFFICE STAFF

Plymouth office. Earn up to \$26 000 depending on exp. robert@penninvestments.com

Auto

Full time File Clerk/Backup Switchboard Operator 40 hours per week with benefits. Apply in person at Gordon Chevrolet 31850 Ford Rd Garden City MI 48135. Resumes can be faxed to (734) 513 1100

BOOKKEEPER / EXECUTIVE ASSISTANT

For small construction company. Quickbooks proficiency and knowledge of construction accounting preferred. Must know Microsoft Office programs. Mail resume to P.O. Box 251718 W Bloomfield MI 48325 1718

BOOKKEEPER

For general contractor in Farmington Hills. Exp through trial balance is required. Send resume & salary requirements b30747@hotmail.com

BOOKKEEPER

Part time must know Excel & QuickBooks. AR AP GL. Fax (734) 451 9687

BOOKKEEPER / OFFICE ADMINISTRATOR

6 attorney Bingham Farms law firm seeks a qualified & experienced bookkeeper/experienced administrator. Tasks will include maintenance of financial & payroll records billing personnel purchasing & all facets of office administration. References required. Please submit resumes by email to sbrawner@sotablaw.com or fax 248 642 9001

CLERICAL

5 30 hrs/wk Seasonal Computer skills Customer service. Starts Jan 2006. 248 543 4400 Glen

Clerical/Administrative

Earn \$12 48/hr Full benefits paid training. Positions with U.S. Government available. Homeland Security Law Enforcement Wildlife and more! 1 800 320 9353 ext 2002

GENERAL CLERICAL

Full time Clerical position available. Qualified person must be able to handle multiple tasks. Have good communication skills both verbal and written. Experience in both Excel and Microsoft Word. Must have basic math skills and the ability to work with others. Please include salary history with resume to Knight Enterprises Inc 40600 Grand River Novi MI 48375 Attn Shirley Trombetta Fax 248-478-1441 Email shirley@knightenterprisesinc.com

LEGAL SECRETARY

Farmington Hills Law Firm seeks experienced litigation/appeal secretary. Minimum 5 years defense litigation experience required as well as knowledge in Word Salary commensurate with experience & qualifications. Email your resume w/salary requirements to ctramont@rlaf.com

OFFICE ASSISTANT

Max Printing full or part time. PC skills required. Flexible hrs. benefits no medical insurance. Family oriented. advancement opportunities \$8/hr & up. 43141 Grand River Novi (248) 348 2240

Help Wanted-Office Clerical 5020

OFFICE / CLERICAL

Construction oriented co seeks individual with knowledge of accounts payable/receivable Microsoft Word Excel & Quick Books. Other duties will include phones typing & filing. Please send resumes to Box 1258 Observer & Eccentric News papers 36251 Schoolcraft Rd Livonia MI 48150

PART TIME GENERAL OFFICE

Organization to keep office running smoothly. General phone skills must have good organizational skills. Mon-Thurs 9-2 email resume to mmccully@mercutoring.com

RECEPTIONIST/ TYPIST

Rapidly growing law firm in Waterford has an excellent opportunity for the right individual. Must be self-motivated intelligent and able to handle 20 line phone system. Typing speed min of 50 wpm. PLEASE FAX SALARY REQUIREMENTS along with resume to 248 836 8652 Attn SUSAN

SECRETARY (Editorial)

Tech society at 12 Mile/Foxgerry in Farmington Hills has immediate opening for highly organized self-starter to perform a wide variety of duties including but not limited to answering phones record keeping correspondence & database maintenance. Exc phone grammar & proofreading skills a must. 2 yrs exp. Must be proficient in computers (Word/Excel). Resumes & salary requirements Director H R Dept EA P.O. Box 9060 Farmington Hills MI 48333 9050 FAX (248) 849 3771

Help Wanted-Dental 5040

DENTAL / BUSINESS OFFICE

Need someone with Dentesch computer experience insurance knowledge and financial arrangements. Full time Southfield area. Please Call Marie 248 352 7722

Dental Assistant & Hygienist

Needed for busy Novi practice. Mon-Wed & Thurs Some Saturdays. Excellent clinical & personal skills a must. Resume to (248) 347 1198

DENTAL ASSISTANT

Full time in Farmington Hills. Exp necessary. Please call 248 474 8060

DENTAL ASSISTANT

Livonia quality dental practice seeks an energetic patient focused assistant. Friendly staff. Exc hours and salary. 2 evenings no weekends. PLEASE CALL 734 953 2995 to schedule an interview

DENTAL ASSISTANT OUTSTANDING OPPORTUNITY

to join a progressive Novi dental office. We are looking for a personable enthusiastic hardworking individual to become a member of our top notch team. We are a cosmetic & restorative practice that is growing and need a vibrant person to join us. Salary commensurate with experience. We also offer medical dental & retirement plans and vacation. We are open Monday-Thursday 8am-6pm. If interested please fax resume to 248 427 9007

Dental Assistant/Receptionist

Tues & Thurs NW suburb. Prefer cross trained individual. als front office & back. Send resume to P.O. Box 530254 Livonia MI 48153 dentalopportunity1@yahoo.com

Dental Patient Coordinator/ Business Assistant

Seeking enthusiastic self-motivated individual who exemplifies excellent people and organizational skills. Excellent compensation & work environment. Dental & computer skills mandatory. Resume (734) 464 4776

Help Wanted-Dental 5040

Hygiene Scheduling Assistant

Livonia group practice seeks a pleasant people person interested in working 2 3 days/wk on a permanent basis. Position requires good phone skills and an ability to multi-task. Please contact Marcie at 734 591 3636

Help Wanted-Medical 5060

Activities Assistant

Faith based nursing home seeks experienced person. Must be computer literate. Part time hours + weekends. Lutheran Home Livonia 29910 Plymouth Rd 734 425 5024 or 734 425 4614 Ext 3014

BILLING SUPERVISOR

Orthopaedic practice 5 10 years reimbursement management exp req'd. Orthopaedic coding preferred. Bachelor's degree in Business or related field. Knowledge of practice management software. Compensation commensurate with exp. Please send resumes to P.O. Box 1251 Observer & Eccentric Newspapers 36251 Schoolcraft Livonia MI 48150

CHARGE NURSE

Livonia retirement community accepting applications for full time and on call positions. *Stable Staff *Competitive wages & benefits. Call or apply in person Woodhaven Retirement Community 29667 Wentworth St Livonia 734 261 9000 or Fax 734 261 9003

CHIROPRACTOR ASSISTANT

Call or apply in person Health Chiropractic office. Self motivated people person multi tasker. Good pay. 401k vacation holidays. Resumes P.O. S 39595 W 10 Mile Rd Suite 112 Novi MI 48375 Or Fax 248 477 8320

DIRECT CARE AIDES

Experienced with spinal cord & head injury a plus. Southfield area (313) 268 7050

LOOK FOR MORE

Observer & Eccentric JOB LISTINGS AT careerbuilder.com

Medical Assistant

Experienced for internal medicine practice in Livonia & Detroit. Fax resume & references to 734 542 0819

MEDICAL ASSISTANT

EXP. MUST. Two Dr family practices. Apr 26 hrs/week. Westland area. 734 729 1150

MEDICAL ASSISTANT

Full time position. Needed for podiatry office. Nursing home exp a plus. Call Jenny 734 542 8100

MEDICAL ASSISTANT

Needed for Livonia Orthopaedic office. Full time/part time some evening hours. Must have 2 yrs medical exp with certificate of completion. Orthopaedic experience is a plus. Please send resumes to P.O. Box 1251 Observer & Eccentric Newspapers 36251 Schoolcraft Livonia MI 48150

MEDICAL RECEPTIONIST

Needed for dermatologist office. 20+ hours. Experience helpful. Fax resume to 734 542 8168 Or call Jenny 734 542 8100

MEDICAL TEAM LEADER

Organized person to handle busy 6 physician practice. Clerical & admin duties. Profit sharing plan. Insurance. Fax credentials to 248 988 9304

ORTHOPEDIC TECHNOLOGIST

Full time/part time. Certification preferred. 3 4 years experience. Please send resumes to P.O. Box 1251 Observer & Eccentric Newspapers

'Rebound Hiring' More Personal Than Hiring



WORKWISE
by Mildred L. Culp

High performance is compelling many employers to ask former employees to come back.

How does the process work on both sides of the desk?

"In the past," says Beth Carvin, CEO of Nobsco Corp., a software manufacturer in Honolulu, "we thought that when a person left, he wasn't loyal and would be gone with the next opportunity. Research is showing that if they find the grass isn't greener, they come back more loyal and stay longer."

Lynn Walters, freelance journalist and writer in Rye, N.H., was recruited back by the Norwood, Mass., branch of FM Global, a leading mutual industrial insurer, after an eight-week maternity leave. (In 1988, the company didn't offer part-time schedules.) She'd worked there nine years, editing a magazine about property conservation "I left on good terms, with all of my projects in order," she says, after training her fill-in, who was hired after Walters resigned.

Hank Park, senior partner out of the Irvine, Calif., branch of the Lucas Group, specializes in recruiting enlisted personnel for civilian jobs through his company's military division. In 2002, he left, taking note of management's

disappointment, for the golfing industry, which he loved. One telephone hunt about interest in returning led to two recruiters inviting him back when three of the company's other seasoned recruiters returned to active duty in late 2004.

"From a personal standpoint," Park says, "it seemed to make sense. When you're surrounded by military people, you form a really tight bond. No matter how long you've been away from that fire, you still have that bond. I'd always known that Lucas' management team believed in rehiring good employees."

'KNOWN QUANTITY'

Seven months after resigning, Walters heard the voice of her former boss on the other end of the telephone. This was the beginning of a five-year return to the company until her second child. She attributes his offer of temporary work to her being "a known quantity," but her technical knowledge of the industry played a role, too. Assignments kept multiplying until a back injury sent her immediate boss home. When the disability became permanent, she received the offer.

"There were several others in the department who also had necessary experience," Walters quips, "but I believe my boss may have thought I had a better 'work' ethic than they had - despite quitting!"

Park attributes his return to virtually

the same factors "past performance and intangible skill sets," such as loyalty and dedication. He'd felt very secure at the company but concedes that its interest in rehiring made him fear failure, spurring him "to work harder and perform well," he says. "When I came back, I was more motivated and loyal than ever." He's a top producer again.

"High performers know the culture and have relationships established," Carvin comments "They get up to speed quickly, because they know the organization." Walters muses, "I believe that as long as it's easy to understand the reason for leaving, the company will be more receptive to re-hiring."

PROCESS

Although these cases make clear that rehiring requires an extremely personal touch, large organizations with heavy recruiting demands may benefit from the new Rebound Recruiting module of WebExit, introduced in late November to collect and analyze data for "rebound hiring." Carvin maintains that exiting employees who disclose online their likes, dislikes and recommendations provide valuable information. "If one person says something negative," Carvin states, "you ask if that's a problem employee. When you start to see 12 people in the same area saying the same things, it's not anecdotal any more." Such information is particularly important for high performers, she mentions, as a record of



Do you rehire good employees?

"hot-button issues" providing substance for organizational change and conversations about returning. Employees indicate whether they'd be interested in being contacted by the company in 75 days, those who assent receive an e-mail about the possibility of returning.

The bottom line is that rehiring may be even more personal than hiring, software or not.
(Dr Mildred L. Culp comments upon the workplace in national media. Copyright 2005 Passage Media.)

Observer & Eccentric

Employment

HOMETOWNlife.com

Help Wanted-Sales 5120

A FAST TRACK TO A SALES CAREER Travel the USA as you develop skills in Outside Sales Paid training transportation lodging furnished Call Success Express Sales Inc today 1 877 646 5050

A NEW CAREER? REAL ESTATE IS BOOMING! Excellent Commissions Great Training **TIM COURTNEY** Oakland/Livingston area (248) 437 2600 **DOUG COURTNEY** W Wayne (734) 459 6222

REMERICA
HOMETOWN

ABSOLUTELY FABULOUS! That is what real estate agents say about our office location in beautiful downtown Birmingham helpful and well trained support staff lovely private offices extensive marketing for their listing & complete training through our Career Development Program CENTURY 21 Town & Country is the #1 firm in the CENTURY 21 franchise for 13 years in a row no other firm has sold more homes than we have Let's meet and I will tell you why! Call Margie at (248) 642-6100

AMERICA'S #1 Producing CENTURY 21 firm in the nation has immediate openings for new and experienced full time real estate professionals! Our proven and successful training program allows for above average earnings! An unbeatable marketing program internet exposure personal website and a support staff will help you meet your goals. Contact Chris Patrick at the CENTURY 21 Town & Country Plymouth office for a confidential interview 734-455 5600

Help Wanted-Sales 5120

An elite residential real estate firm seeks to add a limited number of full time professionals to its highly skilled team of sales consultants If you would like to be considered for a position with a superior company with superior training and support visit us at www.wermanuel.com and click on Is a career in real estate right for you and try our on line interactive assessment We will contact you with the results

WEIR MANUEL
AUTO SALES NEW & USED CRESTWOOD DODGE (734) 421-5700

CLASSIFIEDS WORK!
1-800-579-7355

Career in real estate
Join our growing Canton Office and be part of #1 Franchise System!

- Free pre licensing
- On going training and support!
- Much more!

Discover the difference!
For details Call Lillian Sanderson
COLDWELL BANKER
PREFERRED REALTORS
734-392-6000

Help Wanted-Sales 5120

Control Your Future How does it feel knowing that the year you experience next is being determined by a board of people in a conference room 65 floors above the ground in a meeting you have not been asked to give input nor would your input be listened to if you had a chance to provide it Isn't it time you took charge? Isn't it time you decide what kind of year you are going to have? Isn't it time for you to call Gil Holliday (248) 865 6900 CENTURY 21 Town & Country wants to hear from you and what kind of year you want to have next gilholliday@aol.com

HOLIDAY CASH \$675 \$975/wk Must be clean cut & personable Hiring Immediately (734) 466 9820

INSIDE SALES In Oakland County Industrial products Mechanical aptitude a help Midnight shift Solid co good benefits Resume Box 1258 O&E Newspapers 36251 Schoolcraft Rd Livonia MI 48150

INTERESTED IN JOINING THE SUCCESSFUL CENTURY 21 PREMIER TEAM?
Build your own business Control your own schedule Unlimited income potential Training

- Free In House
- Free Online
- Unlimited Broker Support!
- Prime Canton Location

Call Mary Hipol at (734) 446-4360 or submit resume to maryhipol@century21.com

Help Wanted-Sales 5120

MORTGAGE ORIGINATORS Self motivated & Branch opportunities Start at min 65% commission & as high as 100% Office space available if desired First Alliance Mortgage Call David Blatt for info 248 594 0115

HBA
HOME BUILDERS ADVANTAGE

NEW HOME SALES SPECIALIST Home Builders Advantage Michigan's largest new home sales company is seeking smart friendly motivated candidates to manage sales for new home communities We provide the best training in the industry Benefits income potential 60K+ ability to work weekends Learn more at HBAAdvantage.com Email resume to dcoentreras@hbandvantage.com

FREE CAREER SEMINAR Getting started Start up costs? Potential earnings? Training? Support? Commission split? We'll answer all these questions and more Dec 1st @ 6:30 pm Call 734 459 4700 www.realestatecareers.net **KELLER WILLIAMS REALTY** Plymouth

REAL ESTATE SALES THINKING OF CHANGING CAREERS? LOOKING FOR INDEPENDENCE AND CONTROL OVER YOUR FINANCIAL FUTURE?
Real Estate just may be your answer Comprehensive training and support provided so you can reach your goals 734 455 6000 Weir Manuel Snyder & Ranks 500 S Main St Plymouth

Help Wanted-Sales 5120

Real Estate Agents
A CAREER IN REAL ESTATE!
All Real Estate COMPANIES ARE NOT THE SAME If you are serious about entering the business and profession of Real Estate Sales you owe it to yourself to investigate why we are #1 in the market place and best suited to insure your success #1 Rated Franchise System
•Continuous Individualized Training
•100% Commission Plan
•Group Health Coverage
•Free Pre Licensing
•Latest Technical Computer Programs Enable You To Have The Competitive Advantage
•Unsurpassed Local and National Advertising Exposure
DISCOVER THE DIFFERENCE Call Jim Stevens or Alisha Nead
COLDWELL BANKER
PREFERRED REALTORS
(734)459-6000

SALES ASSISTANT POSITIONS Exciting fast paced environment looking for part time and full time sales assistants with strong computer skills Office hours 11.5 weekdays and weekends available \$10 per hour Fax resume to 734-464 7232

Job Opportunities 5310

Hiring 2005 Postal Jobs \$17 50 \$59 00 hour Full Federal Benefits Paid training/vacation No experience necessary Green Card OK Call 866 907 5285 x9000

Movie extras Actors Models! Make \$100 \$300/day No exp required FI/PT All looks needed! 800 341 0798

MOVIE EXTRAS, ACTORS & MODELS! Make \$75 \$250/day All ages and faces wanted! No exp required FI/PT! 1 800-714 7501

Now hiring for 2005 Postal positions \$18 50 \$59 00/hr Full benefits/paid training & vacations No experience necessary 1 800 584 1775 refer encen #4501

SECRET SHOPPERS NEEDED For store evaluations Get paid to shop Local stores restaurants & theaters Training provided flexible hours Email request 1 800 685 9024 ext 6333

Help Wanted-Part-time 5200

AVON NEEDS Representatives Now! Call 734 425 1947

MACHINIST Flexible hours Ideal for retiree Walled Lake (248) 360 5270

RECEPTIONIST/SPECIAL PROJECTS LEADER Part time approx 20 hours a week Successful candidate will be outgoing and friendly Computer skills a must with a sense of organization Reply to mmoores@suburbaneyecare.com

Help Wanted-Female 5240
ELDERLY blind female needs elderly female to sit with her in Canton from 6-3 30pm 5 days Must have transportation (734) 582 9621

LIVE IN COMPANION for room & board Farmington area Call after 5pm 248 477 7696

Job Opportunities 5310

Hiring 2005 Postal Jobs \$17 50 \$59 00 hour Full Federal Benefits Paid training/vacation No experience necessary Green Card OK Call 866 907 5285 x9000

Movie extras Actors Models! Make \$100 \$300/day No exp required FI/PT All looks needed! 800 341 0798

MOVIE EXTRAS, ACTORS & MODELS! Make \$75 \$250/day All ages and faces wanted! No exp required FI/PT! 1 800-714 7501

Now hiring for 2005 Postal positions \$18 50 \$59 00/hr Full benefits/paid training & vacations No experience necessary 1 800 584 1775 refer encen #4501

SECRET SHOPPERS NEEDED For store evaluations Get paid to shop Local stores restaurants & theaters Training provided flexible hours Email request 1 800 685 9024 ext 6333

Job Opportunities 5310

UP TO \$4 000 WEEKLY! Exciting weekly paycheck! Written guarantee! 11 year nationwide company now hiring! Easy work sending out our simple one page brochure! Free postage supplies! Awesome bonuses! FREE INFORMATION CALL NOW! 1 800 242 0363 ext 4200

WEEKLY \$1 000-\$3 425! Typing from home Data entry workers needed online immediately Everyone qualified NO experience required Never leave your home NO selling Amazing opportunity! Guaranteed program! www.DataEntryPro.com

Weekly possible \$1325! Earn cash daily! Stay home! Mailing our brochures Real opportunity FREE info! Call now! 1 800 679 1640 24 hrs

Work with us Online Make money from home Sell products on online auctions Start making money today! Call 1 800 940 4943 ext 7700

Position Wanted 5340

I AM AVAILABLE TO HELP WITH HOLIDAYS - Can run errands babysit & parties as needed Reasonable rates Call Roxanne 734 560 9401

Childcare Services-Licensed 5360

PLYMOUTH CHILDCARE & LEARNING Open 24 hours 7 days Full and part time 734 459 9566

Childcare/Baby-Sitting Services 5370

Loving Livonia Mother Wishes to watch 2 children full / part time Call Jodie (734) 513 2262

LOVING PLYMOUTH WOMAN With 6 years teaching exp looking to care for 1 to 2 children full time Please call Codee at (734) 667 2040

A word to the wise When looking for a great deal check the Observer & Eccentric Classifieds!

Childcare Needed 5380

BABYSITTER Looking for youthful energetic reliable loving loyal organized college student to care for my 6 yr old twin boys in my Novi home Promptness and reliable transportation a must Various responsibilities Mon Fri 4pm 7pm \$180 weekly Call after 7pm 248 344 4212

NANNY Mature experienced Northville Permanent part time 2 days/week Boys 1 4 & 7 Call 248-444 7266

Business & Professional Services 5620

GIVE YOURSELF THE GIFT OF SOMEONE TO TALK TO Personal Private Supportive Counseling Call Diane 734 635 8030 Plymouth Area Free Private Phone or In Person Consultation

Financial Services 5640

BE DEBT FREE Genesis Financial Debt Management Program Reduce payments and interest eliminate late fees and collection calls Unsecured debt Non profit 1 866 244 8061 Member BBB

Business Opportunities 5740

ALL CASH CANDY ROUTE Do you earn \$800 in a day? 30 machines & candy All for \$9 995 800 893 1185

EARN \$4375 00 WEEKLY! Processing simple E mails online! \$25 per Email sent! Answer simple surveys online! \$25 00 \$75 00 per survey! Free government grants! \$10 000 \$250 000 never repay! www.fastcashathome.com

Earn an Executive Level Income from home Live that abundant lifestyle No selling Not MLM (888) 471 3650 2 min msg www.achievetabundance.biz

FARMINGTON HILLS Collision & Detailing shop Prime location Major accounts included Call Charlie 248 867 2929

Business Opportunities 5740

FREE ENERGY the world's next hot commodity! Renewable Utilities Ltd offers impressive financial rewards for connected direct sales leaders Info 24/7 at 1 800 329 4980

No Boss! No Commute! Create the lifestyle you deserve from home Call for free message 1 800 259 0519 www.RichardFelix.biz

It's All About Results! Observer & Eccentric 1 800-579-SELL

Weekly Salary \$920! Mailing promotional letters from home Genuine opportunity FREE info! Call now! 1 800 930 3714 24 hrs

Announcements
LOOK HERE

Personals 6000

Advertise your product or service to approximately 900 million households in North America's best suburbs by placing your classified ad in over 800 suburban newspapers just like this one Call the Suburban Classified Advertising Network at 888 486 2466 www.suburbannews.org/scan

TELL US A LITTLE HISTORY and we'll write the song! For a GREAT Anniversary Birthday etc etc Gift! tweetytunes.com

Home Based Business 6430

WEEKLY INCOME \$1750!! Nationwide company now hiring envelope stuffers! Easy work from home! Exciting bonuses! Written guarantee! Free information Call now! 1 800 480 9440

Direct.

Classifieds reach thousands of people, every Sunday and Thursday Direct from our press to your porch. We deliver the prospective buyers you want to reach!

Observer & Eccentric

"It's all about results!"
1-800-579-SELL (7355)

www.hometownlife.com

MICH-CAN STATEWIDE CLASSIFIED

FINANCIAL SERVICES
ALL TYPES OF MORTGAGES & HOMEOWNER LOANS! Refinancing Bill Consolidations Home Improvement Back Taxes Any Credit Purchases Foreclosures Fast Cash Closings! Anytime! 1 800 611-3766 Access Mortgage!

EMPLOYMENT
DRIVER - COVENANT TRANSPORT Regional Runs Available Excellent Pay & Benefits Exp Drivers Teams O/O & Students Welcome Refrigerated Now Available 888 MORE PAY (1 888 667 3729)

OWNER OPERATORS OR DRIVERS Wanting to Own!!! Run within 300 miles of home Dry Van Majority Drop/Hook Repeat Lanes and Customers Consistent Home Time & Pay *Flexible Lease Purchase Program* To Learn More Give Us A Call Today!!! 1 888 446-4642 TransCorr

WEEKEND EVENTS
SHIPSHAWANA ON THE ROAD Lansing Center downtown Lansing MI Saturday December 3 from 9 am 6 pm Sunday December 4 from 10 am 5 pm Have your picture taken with live reindeer Sunday noon to 4 pm \$3 00 Adults children 12 and under Free. More info 269 979 8888 www.ShipshawanaOnTheRoad.com

REAL ESTATE
DESTIN, FL Rental rates from \$800/mo! Beachfront/off beach 10% discount for 2 mo reservation Dec to Feb Snowbird activities/golf discounts ECVR & Sales 1 888-23BEACH www.ecvr.com

******ALL MORTGAGE LOANS****** Refinance & use your home's equity for any purpose Land Contract & Mortgage Payoffs Home Improvements Debt Consolidation Property Taxes Cash available for Good Bad or Ugly Credit! 1 800 246 8100 Anytime! United Mortgage Services www.umsmortgage.com

DRIVERS - SEMI-OTR DRIVERS are you just a number? Come work for the Buske Family Good Equip Pay Benefits More Ask our Drivers 800-879 2486 x 286

WE HAVE REGIONAL DRIVERS who'll earn over \$72 000 this year! How much will you earn? Home weekly! We simply offer more! Heartland Express 1 800 441 4953 www.heartlandexpress.com

FOR SALE
3-WEEK BUILDING SALE! "Last Chance!" 20x26 Now \$3995 25x30 \$5700 30x40 \$8300 40x60 \$12 900 Others Meets high snow on a wind End included Pioneer 1 800 668 5422

FLORIDA! Looking for a Home In Paradise? Look no further than Welcome Home Real Estate Magazine The Foremost "Free" Authority on SW Florida's Gulf Coast (800) 395 9373 lshinsky@welcomehome.com

\$\$\$CASH\$\$\$ Immediate Cash for Structured Settlements Annuities Law Suits Inheritances Mortgage Notes & Cash Flows J&J Wentworth- #1 1-(800)794 7310

DRIVERS - SEMI-OWNER OPERATORS! Earn up to \$141 per mile Free Base Plates Permits Dual Com No touch freight! Drivers Check us Out 1 877 613 6365 x286

BUSINESS OPPORTUNITIES
ALL CASH CANDY ROUTE Do you earn up to \$800/day? Your own local candy route Includes 30 machines and Candy All for \$9 995 Call 1 800 814 6472

SERVICES
PLACE YOUR STATEWIDE AD HERE! \$299 buys a 25 word classified ad offering over 1.6 million circulation and 4.2 million readers Plus your ad will be placed on Michigan Press Associations website Contact this newspaper for details

OWN A PRIVATE MOUNTAIN RETREAT Spectacular gated riverfront mountain community near Asheville NC. 1 8 acre

DR DANIELS AND SON REAL ESTATE LOANS AND BUYS LAND CONTRACTS Fast Funding Private Money

HELP WANTED Want to work for a Michigan newspaper? Get a free weekly e-mail list of news paper positions available Visit http://www.michiganpress.org/subscribe.php

REACH 3 5 MILLION Michigan readers with a 2 x 2 display ad for only \$999 Contact this newspaper for details

Observer & Eccentric Home and Service Guide

All Ads Run Online
FREE!
A Value Of Up To \$87.00
www.hometownlife.com

Home & Service
800-245-

Asphalt/Blacktopping 0110

PAVE ASPHALT IT'S NOT TOO LATE Res / Comm Free Est All Work Guar Toll Free 888 248 9597 313 971 9960

Brick, Block & Cement 0290

ALL BLOCK BRICK WORK Conc etc + Foundat ons Res & Comm Lic & Ins Call Anyt me 248 478 2602

Building Remodeling 0310

"ADDITIONS PLUS"
• Beautiful Additions
• Lower Levels
Guaranteed quality workman ship Complete plan & des gn serv ce avai able Lic & Ins 734-414 0448

hometownlife.com

Building Remodeling 0310
DON PARE FINISHED CARPENTRY
Spec a z ng in ktchen bath bsmt ceramic tile remodeling Lic /Ins 734 261 1330

J A FERGUSON CONST
Baths ktchens add t ons roofing sid ng windows basement buid outs new homes 248 363 5975

JANOWSKI BLDG & DEV CO
Exceptional Quality Service & Design at Exquisite Prices Addition renovat on garages surrooms ktchens & baths 734 834 4760

Cabinetry/Formica 0400

D. BLAKER & SON
High end cab netry & furn ture Licnsed & nsured 734 261 9761 734 777 1555

Distributor Omega & Dynasty II Cabinets 52% off retail Kitchens Baths Addit ons A terat ons 734 637 1992

Carpet Repair/Installation 0440

Floor Covering Installations
WHY PAY MORE Des w tn the nstalers d rect We offer car pet tile linoleum ha dwood Fully ins lifetime warranty w/abor Mike 248 249 8100

Chimney Cleaning/Building & Repair 0480
BEST CHIMNEY & Roofing Co
New & repa s S c tizen discount Lic & ns 248 557 5595 313 292 7722

Electrical 0700

FAMILY ELECTRICAL C ty ce t V oations corrected Service changes or any small job Free est 734 422 8080

Firewood 0840

Admire Your Fire
Well seasoned Hard Birch & Fruit Pickup and delivery Hacker Services Quality Since 1946 (248) 348 3150 M F 8 5 Sat 8 3

Floor Service 0880

HARDWOOD FLOORS
Staining Free Shoe Mold Repair Old floors a special ty Economical 734 692 0040

Gutters 1000
AFFORDABLE & PROFESSIONAL
Gutts c eaning and repa rs Fully nsured (313) 438 1885

Home Improvement 1000

BEREAN BUILDERS INC
From chang ng a faucet to complete home remodeling Lic /Ins Free est mates 1 866 424 2157

Handyman M/F 1020

ABSOLUTELY DU IT ALL Lic & Ins
SOLID SURFACE SPECIAL
We also do comp site bsmts & all other interio work ncl elect ca plumbing & painting etc Call Call #248 891 7072

ABSOLUTELY AL S
•Carpentry •Electric •Plumbing •Painting •Roofing 248 477 4742

My Handyman

Trusted Nat onal B and Smal Med um S ze Repa rs Lic •Ins •Guaranteed 734 451 9888

Hauling/Clean Up 1030
A 1 HAULING
Move scrap metal clean basements garages stores etc Low est prices in town Qu ck service Free est Wayne/Cak and Cent a loca ton 547 2764 or 559 6138

Housecleaning 1080

JB HOWARD CLEANING CO
We clean for less Res & Comm Family owned & oper ated 734 718 6027

Housecleaning 1080

CHIPPEWA CONSTRUCTION
Roof ng•S d ng•Gutters•Tr m Home Remodeling & Repa rs Lic & ns 734 414 9160

ROOFING SIDING WINDOWS
35 Yrs exp Lic & Ins Firman Bros Home Improv Free Est (734) 675 2847

Housecleaning 1080

HOUSECLEANING
Available Economical Profess onal Please call 734 484 1908
Call to place your ad at 1-800-579-SELL(7355)

Housecleaning 1080
NEW DEDICATED STYLIST in Livon a lock ng for new cl en tels 10% off any hair service Cal Ruth 734 261 6928 or 248 943 9310

Painting/Decorating Paperhangers 1420

MASTERWORK PAINTING
Interior / Exterior
• Power Wash ng
• Drywal Repair
Complete Prep & Clean Up 20 yrs exp References
Call 734-523-1964
Quality Work / Nice Pnce

Painting/Decorating Paperhangers 1420

PETERSON PAINTING
Custom colors are our specialty Wallpaper Removal Drywall Repa r 30+ yrs exp 734 748 2017 734 414 0154

A ONE CUSTOM PAINTING
★Int/Ext ★Book now for exp d prof painting Free Est Ref /Ins Vasko 248 738-4294

EXPERIENCED PAINTER
Affordab e prices Neat nt/Ext Insured Free Est Suburbs Enc 313 477 2085

CLASSIFIEDS WORK!
1-800-579-7355
INTERIORS R US Int & Ext painting wallpaper removal faux fin shes drywall repairs 734 306 3624 566 872 9832

Painting/Decorating Paperhangers 1420
MASTERWORK PAINTING
Interior / Exterior
• Power Wash ng
• Drywal Repair
Complete Prep & Clean Up 20 yrs exp References
Call 734-523-1964
Quality Work / Nice Pnce

Plastering 1470

★ A 1 Plaster & Drywall ★
•Dust Free Repairs •Water Damage •Cracks & Holes No job too small 35 yrs exp Lic /Ins (248) 478 7949

Roofing 1640

ABANDON YOUR SEARCH
Choose Northern Lights Home Improvement
Just because you have a leak doesn't mean you need a new roof All repairs guaranteed for 2 yrs (313) 304 9344

APEX ROOFING
Quality work completed with prde Family owned Lic Ins For honesty & integrit y 248 476 6984 248 855 7223

BEST CHIMNEY CO
Free est Lic & Ins (313) 292 7722

LEAK SPECIALIST Flashings Valleys Chimneys etc Warr Member BBB 30 yrs exp Lic/Ins 248 827 3233

Snow Removal 1810
AFFORDABLE & PROFESSIONAL
Snow removal Residential/ Commercial Fully insured (313) 438 1885

Tree Service 1980

Affordable • CHEAP • Quality Land Clearing • Tree Service
Fully Ins Romo & Servello 248 939 7416 248 939 7420

FRANK'S TREE SERVICE
Trimming removal stump grinding Free est reason able Insured (734) 306 4992

G & F TREE SERVICE
Payment Options helping you get things done! Trimming removal stump grinding Fully Insured 248 436 6188

IT DOESN'T GET ANY BETTER THAN THIS... Observer & Eccentric Classified!
1-800-579-SELL

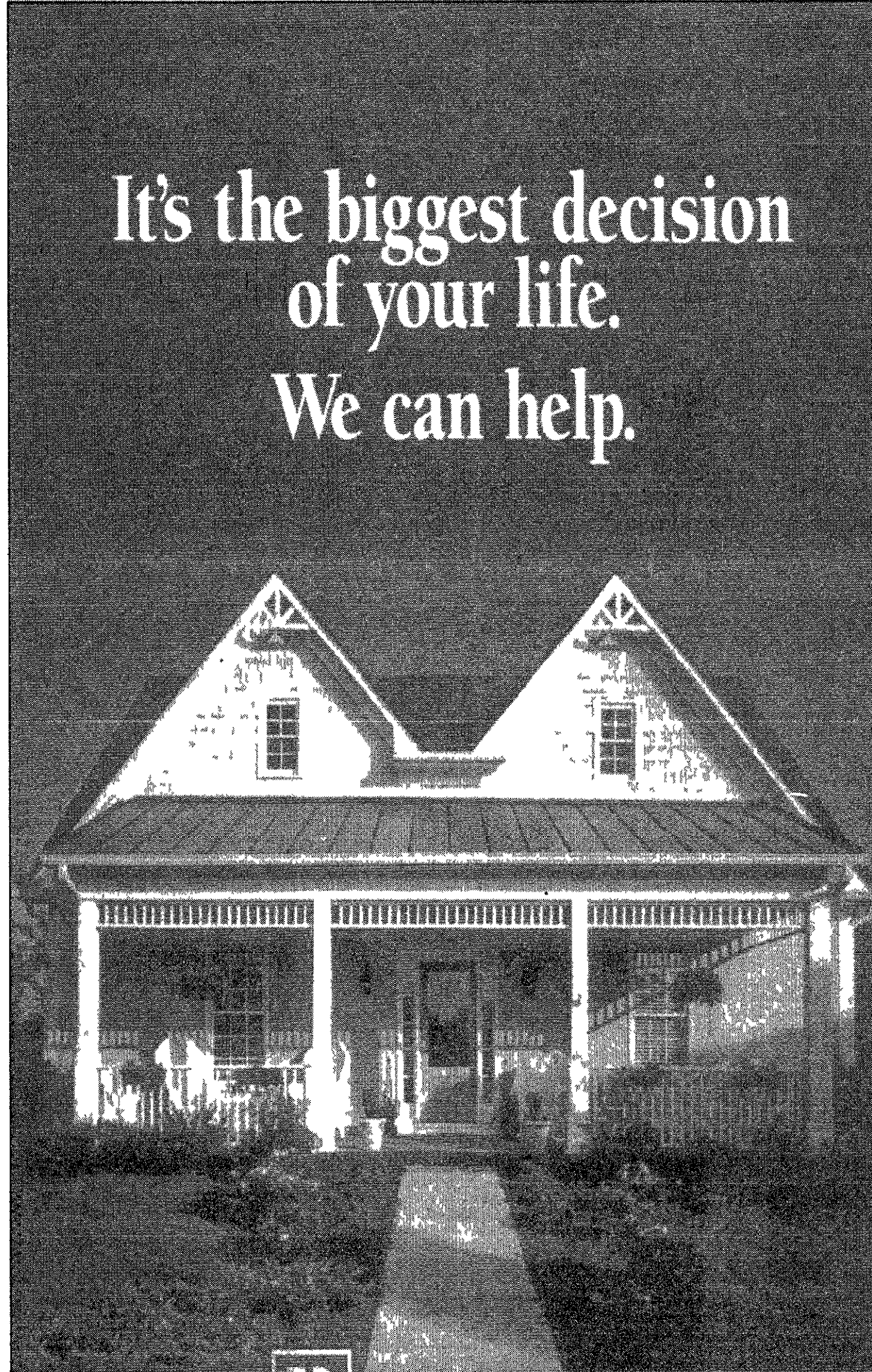

RE REALTOR
We're REALTORS®
Real Estate Is Our Life®

THE Observer & Eccentric NEWSPAPERS
Recomends that you contact a Realtor®

Metropolitan Consolidated Association of Realtors
901 Tower Drive, Suite 190
Troy, MI 48098
248 879-5730

BABY'S FIRST CHRISTMAS!

A perfect addition to baby's scrapbook! Place your baby's photo in the Observer & Eccentric Newspapers for Christmas. This special page of "cuties" will run in our papers on December 25.

Just \$15*
Deadline is 12/16/05
Send picture and info to
Baby's First Christmas
Classified Dept
36251 Schoolcraft
Livonia MI 48150
or email to
customerad@hometownlife.com

JOHN SMITH
Mommy's Little Angel
Born 9/12/2005
Proud Parents
John & Sue
Livonia MI

THE Observer & Eccentric NEWSPAPERS
WHERE HOMETOWN STORIES UNFOLD
6 line maximum Must be Prepa d we accept a l majo c ed t cards
Photos may be ma led o e-ma led but must be received by 12/16/04. No photos w l be retu ned

CHRISTMAS WITH YOUR PETS

Your pets already think they re the stars of the family now let them see it in print Place your pets photo on a special page designed just for them This page will run in our papers on December 25

JUST \$15*
DEADLINE IS 12/16/05
Send picture and info to
Christmas with the Pets
Classified Dept
36251 Schoolcraft
Livonia MI 48150
or email to
customerad@hometownlife.com

THE Observer & Eccentric NEWSPAPERS
WHERE HOMETOWN STORIES UNFOLD
6 line maximum Mus be Prepa d we accept a l majo c ed t cards
Photos may be ma led o e-ma led but must be received by 12/16/04. No photos w l be retu ned

CLASSIFIED

YOUR TICKET TO Buy • Sell • Find

Observer & Eccentric
CLASSIFIED ADVERTISING
1-800-579-SELL (7355)

7000's Merchandise

7000 Absolutely Free
7020 Art Quizzes/Collectibles
7040 Auction on Sales
7060 Rummage Sale/Flora Market
7100 Estate Sales
7110 Garage Sales
7130 Moving Sales
7140 Clothing
7150 Household Goods
7160 Appliances
7180 Pools Spas Hot Tubs
7200 Barges & Buys
7210 Bicycles
7215 Exercise/Fitness Equipment
7220 Building Materials
7240 Business & Office Equipment
7260 Office Supplies
7280 Cameras & Supplies
7300 Commercial/Industrial
7310 Restaurant Equipment
Commercial/Industrial
Machinery For Sale

7320 Computers
7340 Electronic/Audio/Video
7360 Video Games Tapes Movies
7380 Farm Equipment
7400 Farm Produce Flowers
7410 Plants
7420 Uprights
7440 Christmas Trees
7460 Firewood Merchandise
7480 Hobbies & Collectibles
7490 Hosp/ta/med ca. Equipment
7495 Jewelry
7500 Lawn Garden & Snow
7510 Lawn & Garden
7520 Miscellaneous For Sale
7530 Musical Instruments
7540 Sporting Goods
7550 Tools
7560 Trade Or Sell
7570 Wanted To Buy

7800-7930 Animals/Pets

7860 Animal Services
7870 Bachelor Directory
7880 Birds & Fish
7890 Cats
7900 Dogs
7910 Farm Animals/Livestock
7920 Horses & Equipment

7870 Horse Boarding/Concessions
7880 Household Pets/Others
7890 Pet Grooming & Day Care
7900 Pet Services
7910 Pet Supplies
7920 Pets Wanted
7930 Lost & Found Pets

1-800-579-SELL

7000-7200 Merchandise

Absolutely Free 7000

File 1 three drawer metal letter w/lock & key 2 fax machines 1 electric typewriter 1 PA system (734) 522 8569

FIREWOOD & KINDLING Seasoned ready to burn Woodstock 248 673 4701 or 248 991 5236

7000-7200 Merchandise

DEL GIUDICE ANTIQUES

We make house calls estate and private sales and internet sales Insurance and Estate appraisals We are also looking to purchase fine china crystal silver oil paintings furniture costume and fine jewelry Member of ISA

515 S Lafayette Royal Oak Mon Sat 11-6 248 399 2608 Visit our website to www.delgiudiceantiques.com

DOLLS MADAM ALEXANDER 6 inch countries Sale \$35 each Cash 248 474 6186

7000-7200 Merchandise

Antiques/Collectibles 7020

ANOTHER BERNARD DAVIS ESTATE SALE (313) 837 1993

17375 Parkside Detroit Off McNichols between Livernois and Woodward Fri & Sat Dec 2 & 3 9am-4pm

7000-7200 Merchandise

Antiques/Collectibles 7020

THAN AND NOW SHOPPE

Quality Antiques Arts Crafts Dealer's Welcome

108 E Grand River Fowlerville 517 223 7588

7000-7200 Merchandise

Antiques/Collectibles 7020

TOY SHOW Sunday Dec 4 10-3pm 19801 Farmington 734 747 7192 586 795 6261

7000-7200 Merchandise

Antiques/Collectibles 7020

BOUQUET SALE Antiques & Collectibles

Lots of items to choose from Sat Dec 3 10-4pm

Auction Sales 7060

CHRISTMAS SILENT & LIVE AUCTION Friday Dec 2 6:30PM 7 Raffle Hors d'oeuvres Cash bar The Nativity of the Virgin Mary Greek Orthodox Church 6 Mile & Haggerty Plymouth 734 420 0131

ESTATE AUCTION

Sat Dec 3 7pm Cultural Center 525 Farmer Plymouth MI

Antiques/Collectibles Depression/Glassware Porcelain/China/Pottery Furniture

Cash/MC/Visa AmEx/Discover Bank Debit Cards No Checks Doors Open 6pm

J C Auction Services 734 451 7444 jcauctions.com

7100 Estate Sales

An Antique & Collectible Sale! By Everything Goes

Fri Sat Dec 2 & 3 10-4 1303 AVON CIR S off Avon Btwn Crooks & Livernois Rochester Hills

7100 Estate Sales

Antiques/Collectibles 7020

DEL GIUDICE ANTIQUES

We make house calls estate and private sales and internet sales Insurance and Estate appraisals We are also looking to purchase fine china crystal silver oil paintings furniture costume and fine jewelry Member of ISA

7100 Estate Sales

Antiques/Collectibles 7020

THAN AND NOW SHOPPE

Quality Antiques Arts Crafts Dealer's Welcome

7100 Estate Sales

Antiques/Collectibles 7020

TOY SHOW Sunday Dec 4 10-3pm 19801 Farmington 734 747 7192 586 795 6261

7100 Estate Sales

Antiques/Collectibles 7020

BOUQUET SALE Antiques & Collectibles

Lots of items to choose from Sat Dec 3 10-4pm

7100 Estate Sales

FARMINGTON HILLS 46 years in home 1950's modern furniture Hammond Organ Baldwin Piano 200 + Life Magazines records books kitchen too s cameras pool table full of house hold misc 29050 Glenarden take Chesterbrook South off 13 Mile W of Orchard Lake Rd Go W on Wayburn to end then left to address Fri Sat 9-4pm

7100 Estate Sales

FARMINGTON HILLS Fr Sat Dec 2 & 3 10:30-4:00 27520 West 8 Mile Antique furniture lamps clocks fans bedroom dining kitchen art glass costume jewelry old toys doll house Lots of vintage items

7100 Estate Sales

MULTIPLE ESTATE SALE Metropolitan United Methodist Church 8000 Woodward Ave Detroit Dec 10 9-3pm 3:00pm Secured parking

7100 Estate Sales

SPECTACULAR ESTATE SALE! Thurs Sat Dec 1-3 9-5 89 Lakeshore Dr Corner of Warner & Lakeshore Dr South of Moross Designer clothes Jewelry Shoes Purse Many beautiful items! Glassware Christmas decor furniture statuary and more! ESTATE SALES PLUS (586) 795 3252

7100 Estate Sales

GARDEN CITY FREE HALLMARK ORNAMENT & COLLECTIBLE SHOWS 11-4pm

Star Wars Barbies Shirelys Hot Wheels GI Joe's Hummels Beattles Every Sun in Nov & Dec Mr Bigs Stuff 29552 Ford Rd & Middlebelt facing K Mart parking lot 4 ft tables \$12.8 ft \$20 734 691 3252 FREE COMPUTER CLASSES

7100 Estate Sales

W BLOOMFIELD Big holiday moving sale! More accessories home garden clothing shoes furniture 5030 Wallbrook Ct N of 14 W of Inkerster Sat Sun 10-5pm

7100 Estate Sales

BIRMINGHAM Furniture appliances books clothes goods Sat 9-5pm Sun 1-4pm 6711 Woodside Trail 48322 (15 & Middlebelt) 248 626 0316

7100 Estate Sales

CANTON Fri Sun Dec 2-4 8am-5pm possibly later 39410 Koppernck btwn Joy/Warren runs Hwy to Haggerty Furniture fridge etc All must go 734 453 8955

7100 Estate Sales

NORTHVILLE Estate Sale Furniture & misc Sat Sun 10am-6pm 650 East St 248 219 3367

7100 Estate Sales

WEDDING DRESS Stunning satin laced & beaded w/ train & plastic cover for small frame worth \$2000 asking \$1000 248 417 1458

Household Goods 7160

- FURNITURE - LEAVING STATE

Must sell W/II sacrifice beautiful near new furniture items include elegant Italian leather sofa & loveseat (cost over \$3000) will sell both pieces for \$1550) also have beautiful 13 piece formal Chippendale cherry dining room suite 2 king sized cherry 11 piece bedroom suites 2 cherry queen sized bedroom suites cherry five pce game set 3 pce cherry pub table set all wood 9 piece mahogany grandfather clocks two 3 pce cherry coffee table sets gorgeous 24 percent lead crystal and solid brass lamps pictures silk trees etc All less than 3 mos old & in excellent condition Must be sold as soon as possible Private party Please call 248 853 8124

Household Goods 7160

BABY GRAND PIANO Immaculate make offer Patio table 4 chairs washer dryer make offer 248 396 4105

BED Brand New super pillow top mattress set in plastic w/ warranty Must sell! Can deliver 734 231 6622

BED king size \$300/best offer 734 427 7184

Household Goods 7160

BED SLEIGH BED Queen size cherry Brand new in box can deliver \$300 734 326 2744

BEDDING SET 2 piece queen size pillow top mattress set New in plastic with warranty \$160 734 326 2744

Household Goods 7160

BEDROOM SET 7 piece girls honey color wood good condition \$250 248 553 0906

BEDROOM SET Girls twin size 8 pieces Dark Cherry mint condition \$1800/best (734) 425 6090

Household Goods 7160

BEDROOM SET King 6 piece Stunning Lexington Atlantic Overture Fossil stone tops Mattress set included Moving must sell \$6500 Call 248 864 7055

Household Goods 7160

BEDROOM SUITE King size peacan dresser w/ mirror chest night stands head board frame and mattress Queen size bedrm suite w/ storage (248) 780 5197

Household Goods 7160

BOOKS Christmas Decorations oak finish storage cabinet office supplies 734 728 2061

BUFFET Large 2 pieces maple good condition \$150 248 395 1176

Household Goods 7160

DINING ROOM SET Queen Anne 2 leaves 6 chairs 2 w/ arms excellent cond non \$1000 248 489 1353

DINING ROOM SET Formal glass top table 6 ball & claw seat chairs new exec cond Sacr fce Best Offer 248 449 8863 after 6:00 pm

Household Goods 7160

DINING ROOM SET Thomasville pecan ustc pr dining table 8 chairs hutch server Gorgeous Like New Paid over \$8000 Sacrifice \$3600 248 841 5113

Household Goods 7160

DINING SET Bent Bros maple oval double pedestal table 6 chairs 2 ea's incl china cabinet w/ hutch & side buffet Quality turner exc cond Make offer 734 454 0679

Household Goods 7160

DRESSER W/ HUTCH w/ changing table 4 drawer white exec cond on \$250/best K d's white 3 drawer oak \$75/best 248 682 4990

Household Goods 7160

ENTIRE KITCHEN Renovating House Beautiful European style cabinets Corian counter tops & sink many extras All appliances bathrooms Cash & carry Photos available 248 302 2883

Household Goods 7160

FIREPLACE INSERT Buck Stove wood or coal burning used only 4 seasons Complete w/owners manual \$500/best (248) 442 4943

Household Goods 7160

FURNITURE Flexsteel sofa \$75 Love seat \$50 Ethan Allen chair & ottoman \$100 Sligh solid cherry TV cabinet (fits up to 27" TV) \$200 All excellent cond 734 254 1328

Household Goods 7160

FURNITURE Dark oak king frame armoire 2 night stands dresser w/2 mirrors \$950 Dark oak 6 ft table 3 leaves 4 side & 2 arm chairs server china cabinet \$1000 Nutuzzi burgundy leather couch \$700 Glider rocker White w/stool \$75 248 651 3893

Household Goods 7160

FURNITURE Large sleeper sectional Baker's rack with shelves sofa & chair set large entertainment center 734 354 0473

Household Goods 7160

FURNITURE House of Denmark bedroom set Denmark bed screen TV desk set end tables leather furniture etc (313)402 5154

Household Goods 7160

FURNITURE Like new 6 piece sunroom furniture set Rattan/Hawaiian print \$900 (248) 646 5870

Household Goods 7160

FURNITURE 5 pce neutral color sectional 8 piece glass top dining table Black TV units Parsons and occasional chairs Chrome glass cocktail table top quality TV set separate together \$4000 (248) 851 9726

Household Goods 7160

HIGH CHAIR Prima Pappa Cherry TV cabinet china dorm refrigerator Accas sofas Much more (734) 667 2425

Household Goods 7160

KITCHEN TABLE/CHAIRS Round/smoked glass table w/6 grey/black chairs \$400 (248) 530 0699

Household Goods 7160

MASTER KING SUITE Set White 13 piece mattress custom built contemporary top quality one of a kind like new Was \$9800 now \$2500 248 535 1212

Household Goods 7160

MATTRESS PILLOWTOP Brand new in plastic with warranty 248 866 5100

Household Goods 7160

NORTHVILLE HOME (Redecorating) Items for sale Tables chairs dishes art w/ k TRUE Treadmill & much more (248) 344 2162

Household Goods 7160

PERSIAN CARPETS Top quality hand woven for sale by private owner Wool silk & cotton Various sizes & colors Liquidating below cost Good Investment Please Call 313 838 7900 248 357 3911

Household Goods 7160

POOL TABLE 8 solid playing surface Balls stick cues rack Good Condition Disassemble and take with REFERRATOR 1947 Frigi daire good working condition Take with! \$350 734 591 1946

Appliances 7180

APPLIANCES Washer gas dryer 23 cu ft Chest Freezer Small Refrigerator Excellent condition Will separate \$450 313 791 0911

Appliances 7180

Dishwasher Kitchen Aid Whirlpool side by side GE Spacemaker m croware All almost 5 years old best offer MUST GO 734 414 1726

Appliances 7180

FRIDGE SIDE BY SIDE Exec cond \$400 (734) 254 0277

GE WALL GAS OVEN GE gas cook top Remodeling must sell \$75 ea or best offer (734) 464 1529

Appliances 7180

REFRIGERATOR GE \$250/best commercial freezer orig \$1800 asking \$350 (248) 867 6145

REFRIGERATOR Sears side by side runs good good condition \$350/best offer (734) 261 8736

Appliances 7180

REFRIGERATOR AMANA Side by side Clean! \$400 734 453 9284

Appliances 7180

Pools, Spas, Hot Tubs 7190

HOT TUB 2005 Brand New Still in wrapper seats 6 w/ lounge Retail for \$5950 sacrifice for \$2950 734 732 9338

Appliances 7180

Business & Office Equipment 7240

OFFICE FURNITURE Local training and office center closed Computers desks tables chairs and more all equipment must go Matching units sold separately or as group Call for price 248 719 5081

Appliances 7180

TOSHIBA STRATA DK96 PHONE SYSTEM Complete System Operations Box and Phones with 3 main line Phones Handles up to 40 phones \$500 Ask for Chuck (734) 453 8700

Appliances 7180

Electronics/Audio/Video 7340

HOME THEATER SYSTEM HIGH END NEW 900 watts 6 speakers Incl radio tuner \$400/best 248 738 1099 afternoons or evenings

Appliances 7180

Christmas Trees 7420

Christmas Tree Artificial 12 ft top quality very full/realistic f flame retardant \$290 (248) 899 2525

Appliances 7180

Hobbies-Coins, Stamps 7480

LARGE DOLL HOUSE 39 X23 X28 h finished w/ over 50 pces of furniture \$350 (734) 459 7512

Appliances 7180

Miscellaneous For Sale 7500

BLAZING 7 VALLEY SLOTT MACHINE Exec cond Other slot machines avail (810) 231 0724

Appliances 7180

CAR RACK & CARRIER Thule good condition larger size fits most autos \$150 248 651 4365 248 408 8650

Appliances 7180

CAR TOP CARRIER \$75 Great Cond (734) 420 0428

Appliances 7180

FLAMMABLE STORAGE CABINETS 2 available \$250 each 734 261 9761

Appliances 7180

FREE 4 ROOM DIRECTV w/install on! Free DVR! Free DVD player! 3 months free HBO Cinemax Access 225+ channels 100% digital Conditions apply Call now 1 800 963 2904

Appliances 7180

FREE DIRECTV Satellite for 4 rooms FREE Two/DVR Add HDTV 220 channels including locals \$29.99/month First 500 order get FREE DVD player \$66 641 7031 Promo #16026

Miscellaneous For Sale 7500

SMALL COMPACT FREEZER \$75 Great for venison! 734 420 0428

Viagra \$3 75/dose CIALIS \$4 75/dose lowest priced refills guaranteed! FREE SHIPPING! Why pay more? Call Prescrip tion Buyers group 1 800 547 1304

Miscellaneous For Sale 7500

Musical Instruments 7510

LOWKEY ELITE ELECTRONIC ORGAN Roll top cabinet beginner to advanced features full spectrum of sounds \$4000 (lists new \$29 000) 734 455 2304

Miscellaneous For Sale 7500

OBOE Bundy var good cond \$600 Farmington Hills 248 788 2168

Miscellaneous For Sale 7500

ORGAN KIMBALL The Enter tainer Model M45 Performer type Good condition SN 386624 248 952 0270

Miscellaneous For Sale 7500

PIANO Baby Grand 2002 Boston By Steinway 5 1 Model GP158 Satin Ebony As New Bloomfield Hills \$13 500 248 593 5932

Miscellaneous For Sale 7500

STEINWAY PIANO MODEL B w/ player Excellent condition 3 yrs old 313 492 9539

Miscellaneous For Sale 7500

WANTED!!! OLD GIBSON LESS PAUL GUITARS!!! Especially 1950's models! Fender Gibson Martin Gretsch D Angelo Rickenbacker Stromberg Epiphone! (1900's to 1970's) TOP DOLLAR PAID!!! Old amplifiers too! CALL TOLL FREE 1 866 433 8277 TODAY!

Miscellaneous For Sale 7500

ANTIQUE POOL TABLE 248 477 7698

POOL TABLE 8 Olhausen custom St Andrews brass accessories package (Originally \$6800) Best over \$2500 248 646 9816

Miscellaneous For Sale 7500

POOL TABLE New n box 8ft 1 slate \$1250 (734) 732 9938

POOL TABLE 4x8 8' like new \$900 248 334 1022

Miscellaneous For Sale 7500

POOL TABLE Olhausen carved solid oak 7 ft Matching oak pub table 4 upholstered swivel oak pub chairs All accessories incl billiard table light corner cue stand balls rack sticks etc Great condition Like new \$2500 248 886 0180

Miscellaneous For Sale 7500

POOL TABLES Factory 2nd Clearance 1 Day Only Sat. Dec. 3rd 10-5

8 ft Slate Maple Carved legs Cost was \$3199 Now! \$577 Free install Balls & Cues (734) 676-7295

Miscellaneous For Sale 7500

Miscellaneous For Sale 7500

BLAZING 7 VALLEY SLOTT MACHINE Exec cond Other slot machines avail (810) 231 0724

Miscellaneous For Sale 7500

CAR RACK & CARRIER Thule good condition larger size fits most autos \$150 248 651 4365 248 408 8650

Miscellaneous For Sale 7500

CAR TOP CARRIER \$75 Great Cond (734) 420 0428

Miscellaneous For Sale 7500

FLAMMABLE STORAGE CABINETS 2 available \$250 each 734 261 9761

Miscellaneous For Sale 7500

FREE 4 ROOM DIRECTV w/install on! Free DVR! Free DVD player! 3 months free HBO Cinemax Access 225+ channels 100% digital Conditions apply Call now 1 800 963 2904

Miscellaneous For Sale 7500

FREE DIRECTV Satellite for 4 rooms FREE Two/DVR Add HDTV 220 channels including locals \$29.99/month First 500 order get FREE DVD player \$66 641 7031 Promo #16026

Sporting Goods 7520

TURBO AIR HOCKEY TABLE 7x3 5 Five yrs old like new Pucks & paddles included Electronic scoring \$200/best 248 703 0290

Sporting Goods 7520

Wanted to Buy 7540

OLD GUITARS WANTED! Fender Gibson Gretsch Martin 1930's 1960's 150p cash paid! 1 800 401 0440

Sporting Goods 7520

Birds & Fish 7820

FISCHER LOVEBIRDS With or without cage \$30 Fair or \$50 w/cage 248 735 1589

Sporting Goods 7520

Cats 7830

HONEY HUGGY Spayed female gray & orange green eyes Abandoned needs good home (248) 486 3588

Sporting Goods 7520

Dogs 7840

BORDER COLLIER PUPPIES LTD shots worming born 9/26/05 ready to go! black and white Very friendly and level headed \$350 248 767 9599

Sporting Goods 7520

ANTIQUE POOL TABLE 248 477 7698

POOL TABLE 8 Olhausen custom St Andrews brass accessories package (Originally \$6800) Best over \$2500 248 646 9816

Sporting Goods 7520

POOL TABLE New n box 8ft 1 slate \$1250 (734) 732 9938

POOL TABLE 4x8 8' like new \$900 248 334 1022

Sporting Goods 7520

POOL TABLE Olhausen carved solid oak 7 ft Matching oak pub table 4 upholstered swivel oak pub chairs All accessories incl billiard table light corner cue stand balls rack sticks etc Great condition Like new \$2500 248 886 0180

Sporting Goods 7520

POOL TABLES Factory 2nd Clearance 1 Day Only Sat. Dec. 3rd 10-5

8 ft Slate Maple Carved legs Cost was \$3199 Now! \$577 Free install Balls & Cues (734) 676-7295

Sporting Goods 7520

Miscellaneous For Sale 7500

BLAZING 7 VALLEY SLOTT MACHINE Exec cond Other slot machines avail (810) 231 0724

Sporting Goods 7520

CAR RACK & CARRIER Thule good condition larger size fits most autos \$150 248 651 4365 248 408 8650

Sporting Goods 7520

CAR TOP CARRIER \$75 Great Cond (734) 420 0428

Sporting Goods 7520

FLAMMABLE STORAGE CABINETS 2 available \$250 each 734 261 9761

Sporting Goods 7520

FREE 4 ROOM DIRECTV w/install on! Free DVR! Free DVD player! 3 months free HBO Cinemax Access 225+ channels 100% digital Conditions apply Call now 1 800 963 2904

Sporting Goods 7520

FREE DIRECTV Satellite for 4 rooms FREE Two/DVR Add HDTV 220 channels including locals \$29.99/month First 500 order get FREE DVD player \$66 641 7031 Promo #16026

MAKE SOME EXTRA HOLIDAY CASH

Sell your household items by advertising in the Observer & Eccentric Classifieds

Only \$3.50 per line!

If you don't sell your item you can renew for 50% off.

Your ad will appear in The Observer & Eccentrics in Birmingham, West Bloomfield, Rochester, Troy, Southfield, Farmington, Clarkston, Lake Orion, Oxford, Livonia, Plymouth, Canton, Redford, Garden City, Westland as well as either the Mirror Oakland OR Mirror Macomb

Call today 1-800-579-7355

Two issue 5 line minimum Offer valid through Dec 31st 2005

DuMouchelles

Auction at the Gallery

FEATURING THE ESTATE OF MARY HOLLAND FORD GROSSE POINTE FARMS MI THE COLLECTION OF SYBIL JACQUES GROSSE POINTE FARMS MI OVER 1800 CATALOGED LOTS

FINE ART APPRAISERS & AUCTIONEERS SINCE 1927 409 E JEFFERSON WE DELROIP TEL (313)963-6255 FAX (313)963 8199 www.DUMOART.com OE0839383

Michigan Humane Society ADOPT-A-PET

This Week's Featured Pet

Meet Ariel a very pretty two year-old reddish brown Labrador Retriever/Vizsla mix She is a very sweet natured dog who loves to spend time with her favorite folks Ariel is loving and affectionate and enjoys being petted She is quite a smart dog She is learning to walk nice on a leash sit and not to jump when greeting people

To adopt Ariel VISIT THE Michigan Humane Society Berman Center for Animal Care, Westland 734-721-7

Observer & Eccentric



Automotive

HOMETOWNlife.com

8000's Autos/RV's

8000	Airplanes	8320	Antique/Class c Collector Cars
8020	Boats/Motors	8340	Acura
8030	Boat Parts/Equipment/Service	8360	Buick
8040	Boat Dock/Marinas	8380	Cadillac
8050	Boat Vehicle Storage	8400	Chevrolet
8060	Insurance Motor	8420	Chrysler Plymouth
8070	Motorcycles/Minibikes/Go-Karts	8440	Dodge
8080	Motorcycles-Parts & Service	8460	Eagle
8090	Off Road Vehicles	8480	Ford
8100	Recreational Vehicles	8500	Geo
8110	Snowmobiles	8520	Honda
8120	Campers/Motor Homes/Trailers	8540	Hyundai
8130	Construction Heavy Equipment	8560	Kia
8140	Trailers	8580	Jaguar
8150	Auto MISC	8600	Jess
8160	Auto/Truck Parts & Service	8620	Jeep
8170	Auto Rentals/Leasing	8640	Lincoln
8180	Auto Financing	8660	Mazda
8190	Autos Wanted	8680	Mercury
8200	Junk Cars Wanted	8700	Nissan
8210	Trucks For Sale	8720	Pontiac
8220	Mini-Vans	8740	Saturn
8230	Vans	8760	Toyota
8240	4 Wheel Drive	8780	Volkswagen
8250	Sports Utility		
8260	Sports & Imported		

1-800-579-SELL

Auto Misc. 6150

VOLVO 960 1992 Parting out new tires 195 65R 15 treadwear 620 with warrant y will separate \$450/best 734 426 8749

Auto Rentals/Leasing 8170

GRAND AM GT 2004 Lease for sale Car is in great cond looking for someone to assume lease to 20 mo at \$222/mo 617 947 4549

Autos Wanted 8190

WE WANT YOUR CAR! ANY CONDITION TOP \$\$\$\$ (free towing) (248) 335 7480 or (248) 939 6123

Junk Cars Wanted 8200

ALL AUTOS TOP\$\$ Junked Wrecked or Running E & M 248 474 4425 Evenings 734 717 0428

WRECKED & JUNK CARS WANTED! 8210

(734) 282-1700

Trucks for Sale 8220

FORD F150 2001 6 cylinder auto Extended cab immaculate! \$9999 **TYME (734) 455 5566**

FORD F150 2003 Supercab 23K \$15 995 Certified **Bill Brown Ford (734) 522-0030**

FORD F150 XLT 2002 73 000 mile super cab V6 tow pkg air Tonneau cover Black Exc cond \$8500 (734) 397 0692

FORD RANGER 1999 Extended cab XLT off road Flareside 4 0 V 6 leather low miles \$9 450 **JOHN ROGIN BUICK 734 525 0900**

FORD RANGER 2002 Super cab green certified clean \$11 495 \$200 free gas **Bill Brown Ford (734) 522-0030**

FORD RANGER 2002 Supercab low miles flareside white \$10 995 **Bill Brown Ford (734) 522-0030**

GMC 2004 Regular Cab chrome auto cool cover \$11 950 4 9% **Only At Lou LaRiche Chevrolet Your Hometown Chevy Dealer 888-372-9836**

Mini-Vans 8240

CHRYSLER TOWN & COUN TRY 2003 Limited all options \$17 888 **Fox Hills Chrysler-Jeep (734) 455 8740**

CHRYSLER TOWN & COUN TRY LX 2002 33K clean \$8 995 **Fox Hills Chrysler-Jeep (734) 455 8740**

DODGE GRAND CARAVAN 1997 Loaded well maintained 313 408 8579

FORD WINDSTAR 1999 green 68K only \$5 695 **Bob Jeannotte Pontiac (734) 453 2500**

FORD WINDSTAR 2002 Sport psw/pl alloy wheels cruise cassette CD \$11 995 **Saturn of Plymouth (734) 453 7890**

FORD WINDSTAR SEL 2003 leather loaded certified \$14 995 \$200 free gas **Bill Brown Ford (734) 522-0030**

GMC SAFARI 2003 nice only \$10 550 **BILL FOX CHEVROLET 888 253 2481**

GMC SAFARI LT 2003 8 pas senger low miles \$14 950 **JOHN ROGIN BUICK 734 525 0900**

HANDICAP VANS BOUGHT & SOLD Best prices best deals for over 30 years. Please call Dale 517 230 8865

MERCURY VILLAGER 1996 dark blue 7 passenger V 6 95K \$4 695 Family vehicle **COLLINS MOTOR SALES (734) 721 1616**

MERCURY VILLAGER 1999 low miles super clean \$7 995 **Bill Brown Ford (734) 522-0030**

MERCURY VILLAGER 2001 red sport leather alloy wheels psw/pl tilt cruise CD \$10 495 **Saturn of Plymouth (734) 453 7890**

MERCURY VILLAGER ESTATE 1999 jewel green loaded 1 owner low miles \$7 950 **JOHN ROGIN BUICK 734 525 0900**

OLDS SILHOUETTE GLS 2003 silver leather chrome loaded \$15 950 **JOHN ROGIN BUICK 734 525 0900**

CHEVY SILVERADO LS 2004 auto vent psw/pl tilt cruise alloys CD 19K \$13 995 **Saturn of Plymouth (734) 453 7890**

4 Wheel Drive 8280

F 350 1999 4x4 low miles dually 9 foot Fisher snow plow \$18 500 248 347 6099

FORD F 150 1998 V 8 4x4 w/custom cap red w/many extras loaded & ready to go! \$8 695 **COLLINS MOTOR SALES (734) 721 1616**

FORD F150 2002 Super Cab 4x4 off road silver clean \$15 995 \$200 free gas **Bill Brown Ford (734) 522-0030**

FORD F250 2003 Supercab DSL 4x4 Lariat \$28 995 **Bill Brown Ford (734) 522-0030**

GMC CANYON 2005 SLE Crew Cab 4x4 only \$16 900 **BILL FOX CHEVROLET 888 253 2481**

GMC EXTENDED CAB 2002 leather chrome (black beauty) SLT 4x4 \$16 450 **Only At Lou LaRiche Chevrolet Your Hometown Chevy Dealer 888-372-9836**

JEEP WRANGLER 2002 2 Dr air CD 1 owner ps am fm stereo 44 000 miles Convertible \$11 000 248 890 6767

Sports Utility 8290

DODGE DURANGO SLT 2004 AWD extra clean \$19 500 **BILL FOX CHEVROLET 888 253 2481**

FORD 2001 EXPLORER SPORT 4x4 V6 black with leather loaded moon very good cond 65 000 miles \$8900 248 227 1617

FORD 2001 Explorer Sport 4x4 black beauty Satellite radio full power 65 000 miles Exceptional condition 3K oil change \$9000 248 477 8575

FORD ESCAPE 2002 PWD green XLS V 6 auto psw/pl tilt cruise alloys CD \$10 995 **Saturn of Plymouth (734) 453 7890**

FORD ESCAPE XLT 2001 copper V 6 leather loaded just \$9 950 **JOHN ROGIN BUICK 734 525 0900**

FORD ESCAPE XLT 2002 4x4 32K 1 owner extra sharp & winter ready \$14 900 **Sesi Lincoln Mercury Mazda Ypsilanti (734) 482 7133 or toll free 1 888 565 0112**

FORD ESCAPE XLT 2003 4x4 low miles \$16 995 **Bill Brown Ford (734) 522-0030**

FORD EXPLORER 1994 4WD All options \$3350 **TYME (734) 455 5566**

FORD EXPLORER 2002 V 8 dark blue 4 dr \$10 995 **Bob Jeannotte Pontiac (734) 453-2500**

FORD EXPLORER 2003 Eddie Bauer 4x4 low miles certified \$16 995 **Bill Brown Ford (734) 522-0030**

FORD EXPLORER SPORT 1999 low miles leather moonroof 4x4 \$8 495 **Bill Brown Ford (734) 522-0030**

FORD EXPLORER XLT 2000 blue leather loaded w/moon roof 4x4 \$6 995 Great for Winter **COLLINS MOTOR SALES (734) 721 1616**

FORD EXPLORER XLT 2000 priced to sell \$7 888 **Fox Hills Chrysler-Jeep (734) 455 8740**

FORD EXPLORER XLT 2001 burgundy 4x4 Good miles a great SUV \$8 995 **COLLINS MOTOR SALES (734) 721 1616**

FORD EXPLORER XLT 2002 V 8 moon 3rd row seat \$16 995 \$200 free gas **Bill Brown Ford (734) 522-0030**

FORD EXPLORER XLT 2003 4x4 low miles nice \$15 995 **Bill Brown Ford (734) 522-0030**

GMC ENVOY XL 2003 4x4 leather moon chrome like new save! \$18 950 **JOHN ROGIN BUICK 734 525 0900**

GMC ENVOY XL 2003 blue DVD 4x4 only \$14 395 **Bob Jeannotte Pontiac (734) 453-2500**

GMC ENVOY 2005 Clean 32 200 miles 4 wd loaded \$18 900/best 734 476 9370

GMC YUKON 2004 silver 5310 V 8 loaded leather 3rd row seat \$28 500 **BILL FOX CHEVROLET 888 253 2481**

HONDA CRV 2003 AWD EX black roof psw/pl tilt cruise CD \$14 995 **Saturn of Plymouth (734) 453-7890**

LINCOLN NAVIGATOR 2005 Ultimate 10K extra loaded showroom new \$43 900 **Sesi Lincoln Mercury Mazda Ypsilanti (734) 482 7133 or toll free 1 888 565 0112**

MAZDA TRIBUTE ES 2003 4x4 loaded 1 owner extra nice \$13 900 **Sesi Lincoln Mercury Mazda Ypsilanti (734) 482 7133 or toll free 1 888 565 0112**

MERCURY MOUNTAINEER 02 15K miles 20" chrome black cd mint cond adult owned \$16 000 (734) 716 0486

MERCURY MOUNTAINEER 2002 V 8 AWD black \$13 495 **Bob Jeannotte Pontiac (734) 453-2500**

MERCURY MOUNTAINEER 2004 V 8 AWD 7K leather 1 owner like new \$21 500 OPEN SATURDAY **Sesi Lincoln Mercury Mazda Ypsilanti (734) 482 7133 or toll free 1 888 565 0112**

OLDS BRAVADA 1999 AWD Great condition! \$2900 **TYME (734) 455 5566**

SATURN VUE 2003 orange stick psw/pl tilt cruise air ABS traction CD \$12 995 **Saturn of Plymouth (734) 453 7890**

TROOPER LS 2000 white 4x4 1 owner, sharp! \$10 950 **JOHN ROGIN BUICK 734 525 0900**

Sports & Imported 8300

CORVETTE 2001 Coupe only 37K \$26 950 **BILL FOX CHEVROLET 888 253 2481**

CORVETTE 2002 black on black Convertible 42K \$32 950 **BILL FOX CHEVROLET 888 253 2481**

FIAT X19 1980 92 000 miles second owner complete his tory newer battery & spark plugs Runs/drives great \$2500/best (734) 455 2304

MERCEDES 1986 500 SEL 133 000 miles great cond \$10 000 (248) 851 8281

Antique/Classic Collector-Cars 8320

CHEVROLET CAPRICE 1975 White convertible V8 exc cond \$7400 (248) 545 1391

ELDORADOS 1983 2 south ern cars needs repair \$2100/best (248) 426 9812

FORD GALAXY 1965 390 black/black 75K miles \$4900 (248) 347 6089

FORD MUSTANG CONVERTIBLE 1991 5 0 L No rust! Fla car 130 000 miles needs top \$1900 (313) 805 2946 or (734) 207 0857

MUSTANG 1966 Ford \$750 or best offer Runs well Please call Ron btwn 12 Noon & 5 pm Mon Fri 248 348 4403

Chevrolet 8400

Local residents Stop & Save at Collins Motor Sales We have the right deals at the right prices **(734) 721 1616**

Financing available for everyone Sale ends December 9th

MALIBU 2003 \$8 900 3 to choose from **Only At Lou LaRiche Chevrolet Your Hometown Chevy Dealer 888-372-9836**

MALIBU 2005 black 2 2 4 cylinder auto great on gas only 10K save \$13 450 **Only At Lou LaRiche Chevrolet Your Hometown Chevy Dealer 888-372-9836**

MALIBU LS 2001 loaded \$7 590 **BILL FOX CHEVROLET 888 253 2481**

MALIBU LS 2001 V 6 loaded \$7 995 **BILL FOX CHEVROLET 888 253 2481**

MALIBU LS 2001 silver 4 dr only \$3 995 **Bob Jeannotte Pontiac (734) 453-2500**

MALIBU LS 2002 loaded \$7 495 **BILL FOX CHEVROLET 888 253 2481**

MALIBU LS 2002 burgundy 1 6 great family vehicle low miles \$8 995 **COLLINS MOTOR SALES (734) 721 1616**

MALIBU LS 2003 black pw/pl tilt cruise alloys CD auto \$12 495 **Saturn of Plymouth (734) 453-7890**

MALIBU LS 2005 program car V 6 GM Certified \$14 500 **BILL FOX CHEVROLET 888 253 2481**

MONTE CARLO 1999 LS 2 door coup 109 000 miles exc condition inside & out \$3500 After 12 noon 248 478 2778

MONTE CARLO LS 2005 bright red loaded factory warranty hurry \$15 950 **JOHN ROGIN BUICK 734 525 0900**

MONTE CARLO SS 2002 heat ad leather seats moon roof \$14 950 **Only At Lou LaRiche Chevrolet Your Hometown Chevy Dealer 888-372-9836**

REGAL 1999 3 8 auto leather loaded see the moon great buy \$5 995 **Only At Lou LaRiche Chevrolet Your Hometown Chevy Dealer 888-372-9836**

REGAL 1999 leather chrome see the moon \$6 950 **Only At Lou LaRiche Chevrolet Your Hometown Chevy Dealer 888-372-9836**

REGAL 2000 Limited chrome leather \$12 888 **Fox Hills Chrysler-Jeep (734) 455 8740**

CONCORDE 2002 Limited chrome leather \$12 888 **Fox Hills Chrysler-Jeep (734) 455 8740**

CONCORDE 1999 White 4 dr 58 000 miles looks great, drives great, new tires \$5299 (734) 414 0646

PLYMOUTH BREEZE 1997 white w/moonroof good miles \$3 995 **COLLINS MOTOR SALES (734) 721 1616**

PT CRUISER LIMITED 2001 leather see the moon \$8 450 **Only At Lou LaRiche Chevrolet Your Hometown Chevy Dealer 888-372-9836**

SEBRING 2002 V 6 leather moon low miles garage kept like new! \$13 650 **JOHN ROGIN BUICK 734 525 0900**

SEBRING LX 2004 4 dr, loaded \$9 595 **Fox Hills Chrysler-Jeep (734) 455 8740**

Boats/Motors 8020

CATALINA 27 Sailboat 1983 roller inboard gas perfect \$7500 (313) 881 8743

Motorcycles/Minibikes/Go-Karts 8070

SUZUKI VOLUSIA 800 2001 Windshield assy bar crash bar black/white low miles \$3500 Patrick 248 770 3903

Snowmobiles 8110

ARCTIC CAT 4402L 1997 Liquid cooled 600 miles/cover Garage kept \$1800 340 Arctic Cat Puma Electric start \$350 734 591 6151

POLARIS 2003 XC M 10 ACE X package electric reverse like new garage kept towed enclosed adult owned \$4 500 (248) 650 8513

Snowmobiles 8110

Skidoo Grand Touring 500 2001 2 up electric start reverse front & rear hand warmers studded stored inside low miles \$2650 Patrick 248 770 3903

CLASSIFIEDS WORK! 8020

1-800-579-7355

Campers/Motor Homes/Trailers 8120

SNOWMOBILE 2003 YAMA HA RX1 Blue Like new 177 actual miles Many extras \$4850 248 386 0495

1985 to 2000 CLASS C motor homes wanted instant cash I come to you Please call Dale 517 230 8865

ChALLENGER 1994 32

Queen bed bath kitchen c/a heat \$8500 734 968 6763

OPEN HOUSE

200 Motor Homes trailers toy boxes cargo trailers Special Buys 05 32 Travel Trailers from \$9 995 We rent HW Motor Homes com 1 800 334 1535

TERRY LITE 1999 Traveler 25' extra hitch assembly \$11 400 734 427 6743

Trucks for Sale 8220

CHEVY S 10 2001 36 000 Miles auto a/c cruise con trol am/fm cassette/cd player \$7650 (734) 522 8709

CHEVY S 10 LS 2004 Crew Cab 4 wheel drive only 7 000 miles call today \$19 950 **JOHN ROGIN BUICK 734 525 0900**

CHEVY SILVERADO 2002 Extended great work truck 36K \$12 450 4 9% **Only At Lou LaRiche Chevrolet Your Hometown Chevy Dealer 888-372-9836**

CHEVY SILVERADO 2 71 2004 4X4 V 8 low miles all extras + bed cover & nirt bars \$22 500 (248) 922 2778

DODGE DAKOTA 2004 Club Cab Sport 32 000 miles 4x4 V 8 good condition \$14 800 (734) 454 7386

DODGE RAM 1998 1500 V 8 loaded 80K Special \$3995 **AUTO CONNECTION 734 968 7979**

FORD F150 1997 1 owner 4 2L 111 000 miles white w/tan cap bedliner \$4500 \$11 400 734 427 6743

Mini-Vans 8240

CHEVY ASTRO 2003 AWD extended White Gold Trim loaded 41 500 miles \$13 500 (248) 486 0731

CHEVY VENTURE 1999 Extended 72 000 miles Built in child seats \$5800 Call 734 612 9096

CHEVY VENTURE 2002 Warner Bros keep the kids busy DVD 8 passenger now only \$12 950 **Only At Lou LaRiche Chevrolet Your Hometown Chevy Dealer 888 372 9836**

CHEVY VENTURE 2003 leather DVD one owner \$13 995 **Bob Jeannotte Pontiac (734) 453-2500**

CHEVY VENTURE 2004 unbelievable unbelievable \$13 900 **Only At Lou LaRiche Chevrolet Your Hometown Chevy Dealer 888 372 9836**

CHEVY VENTURE LS 2004 auto vent psw/pl tilt cruise alloys CD 19K \$13 995 **Saturn of Plymouth (734) 453 7890**

Mini-Vans 8240

PONTIAC 2000 MONTANA Van Conversion 37K blue chrome oak pkg \$14 950 **JOHN ROGIN BUICK 734 525 0900**

FORD 350 12 Passenger 2003 42 000 miles excellent cond Loaded \$14 900 734 751 2405

FORD E 150 2001 High Top Conversion silver low miles 1 owner \$11 950 **JOHN ROGIN BUICK 734 525 0900**

FORD E 250 1999 Hightop Conversion Van purple/silver V 8 loaded TV/VCR \$8 995 Home for the holidays **COLLINS MOTOR SALES (734) 721 1616**

FORD E150 2004 Cargo Van great value \$14 995 **Only At Lou LaRiche Chevrolet Your Hometown Chevy Dealer 888-372-9836**

FORD E350 2005 Cube Van 15 Ft 2000 miles air \$23 995 **Bill Brown Ford (734) 522-0030**

PLYMOUTH GRAND VOY AGER 2000 Loaded 79 000 miles new tires good shape will sacrifice \$4900/best (248) 722 1696

Vans 8260

DODGE RAM 2001 Starter/Craft Van Conversion 37K blue chrome oak pkg \$14 950 **JOHN ROGIN BUICK 734 525 0900**

FORD 350 12 Passenger 2003 42 000 miles excellent cond Loaded \$14 900 734 751 2405

FORD E 150 2001 High Top Conversion silver low miles 1 owner \$11 950 **JOHN ROGIN BUICK 734 525 0900**

FORD E 250 1999 Hightop Conversion Van purple/silver V 8 loaded TV/VCR \$8 995 Home for the holidays **COLLINS MOTOR SALES (734) 721 1616**

FORD E150 2004 Cargo Van great value \$14 995 **Only At Lou LaRiche Chevrolet Your Hometown Chevy Dealer 888-372-9836**

FORD E350 2005 Cube Van 15 Ft 2000 miles air \$23 995 **Bill Brown Ford (734) 522-0030**

PLYMOUTH GRAND VOY AGER 2000 Loaded 79 000 miles new tires good shape will sacrifice \$4900/best (248) 722 1696

4 Wheel Drive 8280

CHEVY COLORADO 2005 Crew Cab LS 4x4 25K \$17 900 **BILL FOX CHEVROLET 888 253 2481**

CHEVY SILVERADO 1999 Extended Cab 4x4 pewter 51K cleanest in town! \$13 950 **JOHN ROGIN BUICK 734 525 0900**

CHEVY SILVERADO LS 1999 4x4 58K auto tilt power trailer pkg \$14 985 **BILL FOX CHEVROLET 888 253 2481**

CHEVY SILVERADO LS 2004 Extended cab Winter ready 4x4 save \$17 490 4 9% **Only At Lou LaRiche Chevrolet Your Hometown Chevy Dealer 888-372-9836**

CHEVY SILVERADO LS 2005 Extended cab 4x4 \$18 950 3 9% **Only At Lou LaRiche Chevrolet Your Hometown Chevy Dealer 888-372-9836**

DODGE RAM 2002 Pick up quad cab 4x4 Only \$11 495 **Bob Jeannotte Pontiac (734) 453-2500**

DODGE RAM SLT 2002 4x4 red & ready \$14 995 **Fox Hills Chrysler-Jeep (734) 455 8740**

Cadillac 8380

FOR CARS UNDER \$7 000 With Warranty No Credit Turn Downs **tymeauto.com**

SLS 1998 63K excellent condition \$9 500 (248) 842 4740

STS 2000 Leather power moon Garage kept since new THIS WEEK ONLY \$99 Down 20 mm credit approval by phone **TYME (734) 455 5566**

CAMARO 2002 pewter auto loaded low miles \$10 950 **JOHN ROGIN BUICK 734 525 0900**

CAPRICE 1995 Runs great very smooth ride Black/gray only 69 500 miles Reliable \$3000 313 531 3998

CAVALIER 2004 save gas only \$8 950 **Only At Lou LaRiche Chevrolet Your Hometown Chevy Dealer 888-372-9836**

CAVALIER 2003 2 dr red 4 cylinder auto save \$7 950 **Only At Lou LaRiche Chevrolet Your Hometown Chevy Dealer 888-372-9836**

CAVALIER 2004 4 dr auto air CD low miles \$8 950 **JOHN ROGIN BUICK 734 525 0900**

CAVALIER 2005 blue auto air psw/pl tilt cruise CD \$9 995 **Saturn of Plymouth (734) 453-7890**

COBALT 2005 4 dr 12K air cruise tilt ABS trac CD only \$12 900 **Only At Lou LaRiche Chevrolet Your Hometown Chevy Dealer 888-372-9836**

IMPALA 2001 auto air psw/pl cruise CD \$6 995 **Saturn of Plymouth (734) 453 7890**

IMPALA 2005 all power see the USA 12K only \$13 900 **Only At Lou LaRiche Chevrolet Your Hometown Chevy Dealer 888-372-9836**

IMPALA LS 2000 dark blue loaded \$5 995 **COLLINS MOTOR SALES (734) 721 1616**

IMPALA LS 2001 silver loaded ready to go \$8 495 **COLLINS MOTOR SALES (734) 721 1616**

IMPALA LS 2003 extra clean low mileage \$12 950 4 9% GM Certified financing available **BILL FOX CHEVROLET 888 253 2481**

Dodge 8420

CHRYSLER 300 2005 Limited edition Black/Gray excellent cond Non smoker 28 000 miles \$24 000 (248) 320 0736

CHRYSLER 300M 2003 loaded 36K power moon \$14 888 **Fox Hills Chrysler-Jeep (734) 455 8740**

CONCORDE 1999 White 4 dr 58 000 miles looks great, drives great, new tires \$5299 (734) 414 0646

PLYMOUTH BREEZE 1997 white w/moonroof good miles \$3 995 **COLLINS MOTOR SALES (734) 721 1616**

PT CRUISER LIMITED 2001 leather see the moon \$8 450 **Only At Lou LaRiche Chevrolet Your Hometown Chevy Dealer 888-372-9836**

SEBRING 2002 V 6 leather moon low miles garage kept like new! \$13 650 **JOHN ROGIN BUICK 734 525 0900**

SEBRING LX 2004 4 dr, loaded \$9 595 **Fox Hills Chrysler-Jeep (734) 455 8740**

Ford 8480

CONTOUR SE 1996 V6 All power Low miles Non smoker Excellent! Needs nothing! \$3100 734 552-0094

CROWN VICTORIA 1994 only 70K \$2 995 **Bob Jeannotte Pontiac (734) 453-2500**

CROWN VICTORIA LX 1997 1 owner garage kept retire car new car trade \$7 450 **JOHN ROGIN BUICK 734 525 0900**

CROWN VICTORIA SE 2000 extra loaded trade w/leather sale \$7 995 **Sesi Lincoln Mercury Mazda Ypsilanti (734) 482-7133 or toll free 1 888 565 0112**

ESORT 1999 red auto air cassette \$3 995 **Saturn of Plymouth (734) 453 7890**

ESCORT 1998 Auto Air Clean no rust \$1850 **TYME (734) 455 5566**

Classifieds inside

To place an ad call toll free
1-800-579-SELL (7355)
Fax (734) 953-2232

THE
Observer & Eccentric
NEWSPAPERS
Automotive

The 2006 Lincoln Navigator

Advertising Feature

Thursday DriveTime



BY DALE BUSS

After a highly demanding five-day family trip over Thanksgiving, one of my favorite vehicles of all time remains one of my favorite vehicles of all time the Lincoln Navigator. And it's difficult to pay a higher compliment to a machine and to Ford Motor Co. than that.

We didn't exactly do over the river and through the woods. Actually, what we put a 2006 Navigator through was much tougher than that idyllic but short trip to Grandma's house. Instead, my family and I traveled about 1,000 miles across Michigan and around the lake - Lake Michigan, that is - through the treachery of downtown Chicago, the snow and ice of wintry Wisconsin, and the deep frustration of accident-related backups on Interstate 94 near Battle Creek, until we made it back again.

But all the while, the dependably smooth performance and reliably comfortable amenities in the 2006 Navigator took a huge edge off the aggravation. When we finally got back to the Detroit area to resume our post-holiday lives, we had a hard time wanting to get out of the vehicle!

Let's start by conceding the obvious. Navigator, even in its spruced-up latest version, remains an exemplar of one of the worst aspects of the modern automotive business, gas-guzzling sport-utility vehicles. Even with gasoline hovering at prices closer to \$2 a gallon than the apocalyptic \$3 a gallon of several weeks ago in the aftermath of Hurricane Katrina, Navigator took a big chunk out of my wallet. I had to make a handful of \$40 refuelings during the course of the round trip, which I wasn't happy about.

But just like most of the rest of America, we weren't about to let fuel-consumption concerns or any other economic worries impinge on our annual Thanksgiving trip. And having put that hurdle behind us, there was nowhere we'd rather have been than safely inside this Navigator.

Styling-wise, Navigator doesn't offer all that much. It's huge and boxy, obviously meant to carry a lot of human and other cargo in a commanding and secure position high above most other vehicles on the road. In other words, I don't care that much how it looks. Having said that, however, the 2006 Navigator does retain the happy results of the moderate facelift that the vehicle got with the 2005 model, giving it a



Dale Buss said, "The 2006 Navigator was the smoothest large SUV I've driven."

friendlier and less truck-like appearance.

And no doubt about it. On a walkaround, Navigator is more pleasing to the eye than other SUV behemoth competitors such as Chevy's Tahoe and Suburban models. Navigator's relatively new and subtle appearance enhancements include new side cladding and a boldly horizontal lower air intake on the fascia.

At the same time, the most impressive aspects of the outside of the black Navigator we drove were, not surprisingly, the amenities. Automatically retracting running boards are a first-rate feature, quietly extending out by four inches when a door is opened - and back in when all are closed. Auxiliary turn signals and approach lamps housed in the mirrors are great features that come in handy in myriad ways.

I also got to like Navigator's power lift gate and the separately opening window glass on the rear, though the door swung open a little too slowly for my tastes.

Speaking of power, Navigator was the smoothest large SUV I've driven. The thrust provided by a three-valve V8 engine was fantastic across my range of needs, and the six-speed automatic transmission capably handled the broad range of gear transitions that were required by many kinds of driving and varied conditions. I especially appreciated the ability to

shift from fourth gear to a sixth, overdrive gear manually.

Inside, Navigator really shines. The room it provides throughout the inside of the vehicle is just grand, both for cargo and people.

With the black exterior of the vehicle I drove, Lincoln matched a tan interior that complemented nicely the overall look. The front compartment is roomy and smartly designed, with a huge center console and ample numbers of everything, from vents to stereo speakers.

I do think that Navigator could have made a little more creative use of the center-console space rather than simply using most of it for drink holders. And I don't like having to wait for a little motor to raise the navigation screen from in front of the input for the CD player before I can stick a disk in and play it. But these are minor disputes with an overall very functional passenger compartment.

The second row of seats was equipped with a DVD player and, just as important, reclining captain's chairs so my two teenagers could watch the show in comfort. The DVD screen covered nearly all of what I normally would have seen in my rear-view mirror, which was of significant distress for me, because I've driven vehicles where the obstruction of the view wasn't nearly as complete.

CLASSIFIED INDEX

CLASSIFICATION	NUMBER
Employment	6000-5999
Announcements	6000-6900
Merchandise	7000-7540
Autos/Trucks	6000-8780
Boats, Motors	8020
Motorcycles, Mini Bikes	8070
Trucks	8220

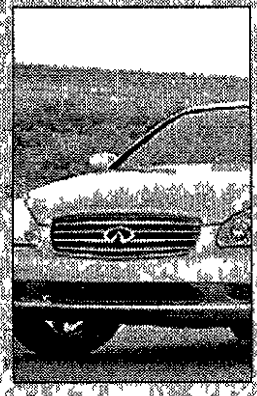

Call Toll Free
1-800-579-SELL (7355)
Fax Your Ad: (734) 953-2232

Walk-In Office Hours
Monday - Friday 8:30 a.m. to 5 p.m.
After Hours Call (734) 591-0900

Deadlines: To place, cancel or correct ads.

Sunday
5:30 p.m. Friday
Sunday Real Estate
5:30 p.m. Thursday
Thursday
5:30 p.m. Tuesday
Thursday Real Estate Display
3 p.m. Monday

View the Observer & Eccentric Automotive Classifieds on the web:
www.observerandeccentric.com

Ford (8480)
FOCUS SE 2004 4 dr 24K auto cruise pw/pl extra nice \$10,900 OPEN SATURDAY
Sesi Lincoln Mercury Mazda Ypsilanti (734) 482 7133 or toll free 1-888-565-0112

Ford (8480)
THUNDERBIRD 1995 V8 Mint cond Original owner Garage kept stored vin ters 31 000 miles Loaded \$7500/best 734 422 7721

Ford (8480)
FOCUS ZTW 2003 Wagon Zetec motor like new low miles \$12,995
Bill Brown Ford (734) 522-0030

Local residents Stop & Save at Collins Motor Sales We have the right deals at the right prices
(734) 721 1616
Financing available for everyone Sale ends December 9th

Ford (8480)
MUSTANG GT 2002 low miles leather 5 speed \$15,995
Bill Brown Ford (734) 522-0030

Ford (8480)
TAURUS 2003 6 to choose from \$11,295
Bill Brown Ford (734) 522-0030

Ford (8480)
TAURUS 2005 1 owner loaded \$12,900
Sesi Lincoln Mercury Mazda Ypsilanti (734) 482 7133 or toll free 1-888-565-0112

Ford (8480)
TAURUS SE 2000 Ford 40 000 miles immaculate new tires brakes battery \$5000 SOLD

Ford (8480)
TAURUS SE 2000 full power aluminum wheels clean car \$5,900.
Only At Lou LaRiche Chevrolet Your Hometown Chevy Dealer 888-372-9836

Ford (8480)
TAURUS SE 2001 Fully loaded all options \$3999
TYME (734) 455-5566

Ford (8480)
TAURUS SE 2002 dark gray leather w/low low miles great vehicle at a great price! \$8,995
GOLLINS MOTOR SALES VIN (734) 721 1616

Ford (8480)
TAURUS SE 2005 auto air pw/pl tilt cruise CD 22K \$11,995
Saturn of Plymouth (734) 453 7890

Ford (8480)
TAURUS SE 1999 Sport Edition Leather loaded 49,800 miles Exc cond \$7000/734 427 8394

Ford (8480)
TAURUS SEDAN 1999 White 36,000 mile 6 cyl auto 4 dr 2 wd clean \$5700 734 658-5648/734 673 6927

Ford (8480)
TAURUS SEL 2001 42K 1 owner leather moon sharp \$7,995
Sesi Lincoln Mercury Mazda Ypsilanti (734) 482 7133 or toll free 1-888-565-0112

REAL-ESTATE at It's best!
Observer & Eccentric

Ford (8480)
TAURUS SES 2000 red leather moon extra sharp \$5,995
Sesi Lincoln Mercury Mazda Ypsilanti (734) 482 7133 or toll free 1-888-565-0112

Ford (8480)
TAURUS SHO 1997 Exc cond all options Sunroof 62 000 miles \$4965 negotiable SOLD

WRECKED & JUNK CARS WANTED!
(734) 282-1700

Honda (8520)
HONDA ACCORD 1996 4 dr low mileage \$4200 248 767 7352

Jaguar (8530)
\$ TYPE 2000 3.0 fire red loaded leather 1 owner \$15,950
JOHN ROGIN BUICK 734 525 0900

Jaguar (8530)
X type 2004 3.0 leather moonroof low miles must see! \$26,995 \$2000 free gas
Bill Brown Ford (734) 522-0030

Jaguar (8530)
GRAND CHEROKEE 2002 leather power moon 42K \$13,995
Fox Hills Chrysler-Jeep (734) 455 8740

Jaguar (8530)
GRAND CHEROKEE 2004 Special Edition leather pw/pl tilt cruise CD/cassette \$16,995
Saturn of Plymouth (734) 453-7890

Jaguar (8530)
GRAND CHEROKEE LAREDO 1999 burgundy V6 4x4 85K \$7,995 Winter special COLLINS MOTOR SALES (734) 721 1616

Jaguar (8530)
LIBERTY LIMITED 2003 black 24 000 miles loaded must see! Save big \$16,950
JOHN ROGIN BUICK 734 525 0900

Jaguar (8530)
LIBERTY SPORT 2003, silver extra clean \$12,995
Fox Hills Chrysler-Jeep (734) 455 8740

Jaguar (8530)
WRANGLER 2003 auto 4x4 6 cylinder Sport \$14,995
Only At Lou LaRiche Chevrolet Your Hometown Chevy Dealer 888-372-9836

Lincoln (8560)
CONTINENTAL 1997 silver loaded \$3,295
Bob Jeannotte Pontiac (734) 453-2500

Lincoln (8560)
LINCOLN LS 2001 All Black Power moon leather \$99 down \$116 mo Why lease when you can own? TYME 734 455 5566

Lincoln (8560)
LS 2004 9K 1 owner loaded & sale priced \$22,900
Sesi Lincoln Mercury Mazda Ypsilanti (734) 482 7133 or toll free 1-888-565-0112

Lincoln (8560)
LS 2004 9K 1 owner moon chromes heated seats like new \$22,900
Sesi Lincoln Mercury Mazda Ypsilanti (734) 482 7133 or toll free 1-888-565-0112

Lincoln (8560)
TOWN CAR 1995 leather sharp blue 86K \$4,495
Bob Jeannotte Pontiac (734) 453-2500

Lincoln (8560)
TOWN CAR 1997 86K 1 owner \$4,995
Sesi Lincoln Mercury Mazda Ypsilanti (734) 482 7133 or toll free 1-888-565-0112

Lincoln (8560)
TOWN CAR 2004 Ultimate 3K 1 owner showroom condition \$25,900
Sesi Lincoln Mercury Mazda Ypsilanti (734) 482 7133 or toll free 1-888-565-0112

Lincoln (8560)
TOWN CAR SIGNATURE 1997 Good cond asking \$5900 Also 1995 Towncar Signature \$4900/best (734) 459 2197

Mazda (8590)
MAZDA 3 2005 HB 14K 5 speed side bags ABS loaded \$16,900
Sesi Lincoln Mercury Mazda Ypsilanti (734) 482 7133 or toll free 1-888-565-0112

Mazda (8590)
MAZDA 6 2005 V6 1 owner loaded like new \$16,900 OPEN SATURDAY
Sesi Lincoln Mercury Mazda Ypsilanti (734) 482 7133 or toll free 1-888-565-0112

Mazda (8590)
MAZDA 6I 2003 4 dr one owner sharp \$11,900 OPEN SATURDAY
Sesi Lincoln Mercury Mazda Ypsilanti (734) 482 7133 or toll free 1-888-565-0112

Mazda (8590)
PROTEGE 5 2003 auto air pw/pl tilt cruise CD alloys ABS \$12,495
Saturn of Plymouth (734) 453 7890

Mercury (8600)
FOR CARS UNDER \$7,000 With Warranty No Credit Turn Downs tymeauto.com

Mercury (8600)
GRAND MARQUIS 2003 12 000 miles premium pack age leather interior mint condition \$14,000 (734) 421 7042

Mercury (8600)
GRAND MARQUIS 2003 low mileage 1 owner loaded w/options \$11,900
Sesi Lincoln Mercury Mazda Ypsilanti (734) 482 7133 or toll free 1-888-565-0112

Mercury (8600)
GRAND MARQUIS 2004 leather low miles \$16,295
Bill Brown Ford (734) 522-0030

Mercury (8600)
GRAND MARQUIS LS 2000 loaded 1 owner great condition \$7,995
Sesi Lincoln Mercury Mazda Ypsilanti (734) 482 7133 or toll free 1-888-565-0112

Mitsubishi (8610)
LANCER ES 2004 full power low miles \$10,888
Fox Hills Chrysler-Jeep (734) 455 8740

Oldsmobile (8640)
ALERO GL SEDAN extra clean all power 66K \$6,995
BILL FOX CHEVROLET 888 253 2481

Oldsmobile (8640)
AURORA 1998 white leather & loaded w/moonroof A very nice vehicle! Good miles \$7,595
COLLINS MOTOR SALES (734) 721 1616

Oldsmobile (8640)
DELTA LSS 1997 white leather all loaded 1 owner great value at \$8,950
JOHN ROGIN BUICK 734 525 0900

Oldsmobile (8640)
INTRIGUE 1999 silver loaded ready to go! \$5,995
COLLINS MOTOR SALES (734) 721 1616

Pontiac (8680)
AZTEK 2003 beige loaded 37K \$12,495
Bob Jeannotte Pontiac (734) 453-2500

Pontiac (8680)
BONNEVILLE SLE 2003 all power on star only \$16,995
Only At Lou LaRiche Chevrolet Your Hometown Chevy Dealer 888-372-9836

Pontiac (8680)
FIREBIRD 1995 New motor /trans new parts T top leather keyless entry \$2500/best 734 718 3141

Pontiac (8680)
GRAND AM GT 2003 Coupe 2 to choose chromes moons loaded \$11,900
Only At Lou LaRiche Chevrolet Your Hometown Chevy Dealer 888-372-9836

Pontiac (8680)
GRAND PRIX GT 2003 Coupe 2 to choose chromes moons loaded \$11,900
Only At Lou LaRiche Chevrolet Your Hometown Chevy Dealer 888-372-9836

Pontiac (8680)
GRAND PRIX SPECIAL EDITION 2003 dark blue power moon leather 35K
Bob Jeannotte Pontiac (734) 453-2500

Pontiac (8680)
MONTANA 1999 Mint cond 4 air bags garaged loaded alloy wheels all power trac control \$4995 248 432 0086

Pontiac (8680)
GRAND AM GT 2004 red V6 auto air \$11,495
Bob Jeannotte Pontiac (734) 453-2500

Pontiac (8680)
GRAND AM SE 2004 auto air & more 2 to choose \$9,995
Bob Jeannotte Pontiac (734) 453-2500

Pontiac (8680)
GRAND PRIX 1999 SE Original owner 70 000 miles 3 8 V6 exc cond many extras \$5300 313 565 7966

Pontiac (8680)
GRAND PRIX 2005 chrome wheels so sharp might cut you \$13,950 \$4,995
Only At Lou LaRiche Chevrolet Your Hometown Chevy Dealer 888-372-9836

Pontiac (8680)
GRAND PRIX GT 2003 black loaded priced to go \$10,950
Only At Lou LaRiche Chevrolet Your Hometown Chevy Dealer 888-372-9836

Pontiac (8680)
GRAND PRIX GT 2003 red power moon leather 38K
Bob Jeannotte Pontiac (734) 453-2500

Pontiac (8680)
GRAND PRIX GT 2004 leather roof moonson heads up display XM \$17,495
Saturn of Plymouth (734) 453 7890

Pontiac (8680)
GRAND PRIX GT SEDAN 2000 V6 air 4W ABS Traction control Alloy wheels \$4995 734 453 7161

Pontiac (8680)
GRAND PRIX SPECIAL EDITION 2003 dark blue power moon leather 35K
Bob Jeannotte Pontiac (734) 453-2500

Pontiac (8680)
MONTANA 1999 Mint cond 4 air bags garaged loaded alloy wheels all power trac control \$4995 248 432 0086

Pontiac (8680)
SUNBIRD 1990 Good condition Many new parts \$1500/best offer 734 453 4956

Pontiac (8680)
SUNFIRE COUPE 2005 22K only \$9,995
Bob Jeannotte Pontiac (734) 453-2500

Pontiac (8680)
SUNFIRE SE 2005 bright red auto air loaded spoiler save big \$11,950
JOHN ROGIN BUICK 734 525 0900

Pontiac (8680)
TRANS AM 1999 V8 Convertible auto bright red leather chromes \$11,950
JOHN ROGIN BUICK 734 525 0900

Pontiac (8680)
VIBE 2004 silver auto air pw/pl tilt cruise alloys CD ABS \$13,995

Pontiac (8680)
Saturn of Plymouth (734) 453 7890

Pontiac (8680)
VIBE 2005 1.8L auto all power great on gas \$14,450
Only At Lou LaRiche Chevrolet Your Hometown Chevy Dealer 888-372-9836

Pontiac (8680)
ION Q 2004 Coupe red auto air power locks CD \$12,495
Saturn of Plymouth (734) 453 7890

Pontiac (8680)
ION2 2003 silver auto air pw/pl tilt cruise cassette spoiler \$10,995
Saturn of Plymouth (734) 453 7890

Pontiac (8680)
SATURN L100 2002 Silver exc cond 59K miles air auto multi compact disc alloy wheels spoiler front & side air bags cruise pw pl \$7200/best 734 454 1509

Pontiac (8680)
SATURN 1999 Dark Blue Auto Air \$3450
TYME (734) 455 5566

Saturn (8700)
SATURN 2001 Auto Air 70k \$5500
TYME (734) 455 5566

Saturn (8700)
SC2 1996 purple auto air alloys cassette cruise \$5,495
Saturn of Plymouth (734) 453 7890

Saturn (8700)
SC2 1999 loaded w/power moon silver good miles \$5,995
COLLINS MOTOR SALES (734) 721 1616

Saturn (8700)
VUE 2003 Fully loaded \$1100 below Blue Book Only \$99 down
TYME (734) 455 5566

Saturn (8700)
CAMRAY 1995 2 Door auto runs great \$2500
AUTO CONNECTION 734 968 7979

Saturn (8700)
Volvo (8740)
CABRIO 2001 auto air pw/pl tilt cruise 6 disc ABS \$10,995
Saturn of Plymouth (734) 453 7890

Saturn (8700)
Volvo (8740)
VOLKSWAGEN 2001 PASSAT Low miles leather sun roof loaded \$12,000 248 642 3958 248 635 5473

Saturn (8700)
Volvo (8740)
VOLVO 2003 S60 2.5T AWD Low miles leather sun roof loaded \$12,000 248 642 3958 248 635 5473

Saturn (8700)
Volvo (8740)
VOLVO 2003 S60 2.5T AWD Low miles leather sun roof loaded \$12,000 248 642 3958 248 635 5473

Saturn (8700)
Volvo (8740)
VOLVO 2003 S60 2.5T AWD Low miles leather sun roof loaded \$12,000 248 642 3958 248 635 5473

Saturn (8700)
Volvo (8740)
VOLVO 2003 S60 2.5T AWD Low miles leather sun roof loaded \$12,000 248 642 3958 248 635 5473

Saturn (8700)
Volvo (8740)
VOLVO 2003 S60 2.5T AWD Low miles leather sun roof loaded \$12,000 248 642 3958 248 635 5473

Saturn (8700)
Volvo (8740)
VOLVO 2003 S60 2.5T AWD Low miles leather sun roof loaded \$12,000 248 642 3958 248 635 5473

Saturn (8700)
Volvo (8740)
VOLVO 2003 S60 2.5T AWD Low miles leather sun roof loaded \$12,000 248 642 3958 248 635 5473

Saturn (8700)
Volvo (8740)
VOLVO 2003 S60 2.5T AWD Low miles leather sun roof loaded \$12,000 248 642 3958 248 635 5473

</

After Thanksgiving SALE

THURSDAY • DECEMBER 1st • OPEN 9 AM - 9 PM

ALL 2005 MODELS BELOW A-PLAN PRICE!

HURRY LAST 2 DAYS! Programs End Friday December 2nd

NO REASONABLE OFFER REFUSED!

2006 Explorer Eddie Bauer 4x2
 Was \$30,985
NOW ONLY \$23,961* A-Plan
 Stock #60987
 A Plan 24 Mo. Lease Renewal
\$199* Per Month \$1,975 Due At Signing



2006 Fusion S
 Was \$19,215
NOW ONLY \$15,784* A-Plan
 Stock #60890
 A Plan 24 Mo. Lease Renewal
\$155* Per Month \$1,897 Due At Signing



2006 F150 Supercab XLT 4x4
 Was \$35,000
NOW ONLY \$29,223* A-Plan
 Stock #60573
 A Plan 24 Mo. Lease Renewal
\$189* Per Month \$1,936 Due At Signing



Attention Ford Hourly Retirees and Family Members!

2006 Focus ZX4
 Was \$16,020
NOW ONLY \$12,573* A-Plan Automatic!
 Stock #60215
 A Plan 24 Mo. Lease Renewal
\$159* Per Month \$2,023 Due At Signing



WE NEED NICE TRADE INS!
 Bring Us Any Type of Vehicle on Trade RV's, ATV's, Motorcycles, etc. We Take Them all on Trade!
!! Highest Dollar Allowed !!

2006 Escape XLT
 Was \$24,600
NOW ONLY \$19,821* A-Plan
 FOUR WHEEL DRIVE
 Stock #60640
 A Plan 24 Mo. Lease Renewal
\$189** Per Month \$1,782 Due At Signing



2006 Five Hundred SEL
 Was \$24,930
NOW ONLY \$20,374*
 Stock #60374
 A Plan 24 Mo. Lease Renewal
\$159* Per Month \$1,938 Due At Signing



ATTENTION! Ford Hourly Retirees and Family Members!

2006 Freestyle SEL
 Was \$27,985
NOW ONLY \$23,374*
 Stock #60481
 A Plan 24 Mo. Lease Renewal
\$189* Per Month \$1,985 Due At Signing



BRING US ANY COMPETITORS AD AND WE WILL BEAT IT - PERIOD*

FANTASTIC USED CARS Certified Used Cars as low as **3.9%** on Select Models (With Approved Credit) **\$1000 Gift Card** with purchase of used Expedition While supplies last!

OVER 200 TO CHOOSE FROM! Something for Every Budget!

We Need Trade! WE PAY HIGHEST DOLLAR!



aplantheadquarters.com
 37300 Michigan Avenue at Newburgh • Wayne • Just East of I-275

\$500 Extra!
 On you trade-in With the purchase or lease of a new vehicle 1995 or newer less than 100,000 miles. All prior sales excluded. Good through 12/2/05.
ONE PER CUSTOMER



CALL 1-800-275-3673
 www.demmer.com
 Ph. 734.721.2600

*Plus tax title license & destination All applicable rebates included in price **All leases are 12,000 miles/yr With approved credit. \$595 acquisition fee not included in final pay amount. Tax and plates extra See Jack Demmer for complete details. A Plan Purchase and A Plan Leases All offers subject to change due to early print deadlines. Sale ends 12/2/05 * In stock New 05 models only All prices and payments include Z Plan \$1000 Retiree voucher

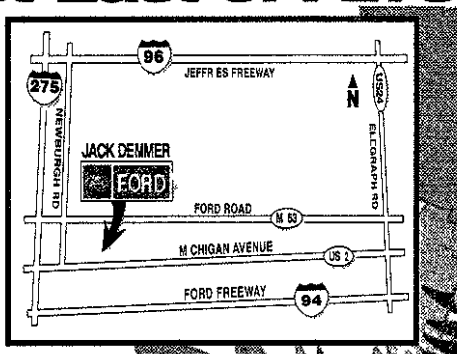

Come On In For Your Best Deal!

PURE ENTERTAINMENT!

HOME LIFE

Thursday December 1, 2005

Handel's 'Messiah'

Page 3

As I Lay Dying

Page 5

Kick it up The Rockettes return to Detroit

Page 8

Metalwork artists demonstrate their craft

A rare form of metalworking technique will be demonstrated at the Ann Arbor Art Center's Gallery Shop 1-3 p.m., Sunday, Dec. 4

The technique, where metal is pierced using a jewelry saw, isn't often seen in today's metalwork pieces. However, the styles are used by artists Paul Wizynajty and David Barber of Man in the Moon Metalworks based in Flint.

The artists have created intricately cut holiday ornaments and wind chimes featured at the shop.

The ornaments' themes are derived from folk and fairy tales, historical events and cultural symbols plus animals and trees.

The demonstration is free. For more information, call (734) 994-8004 Ext. 118. The Art Center is located at 117 W. Liberty St. in Ann Arbor.

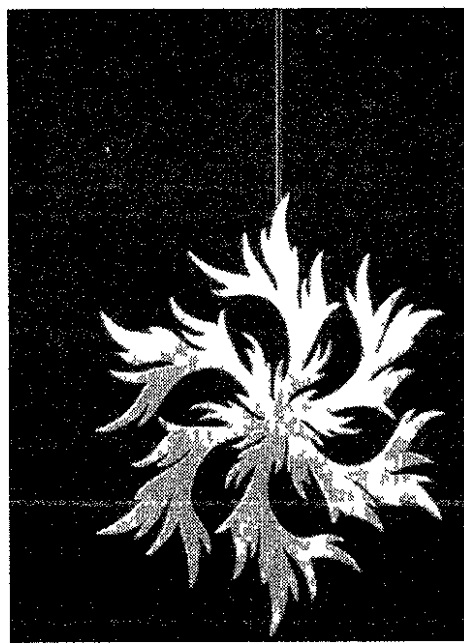

Intricately cut metal ornaments are on display at the Ann Arbor Art Center.



Concert fun with the Beatles and Metallica?

Since it's been a while since I've talked JUST concerts

Concerts!

Things are slowly up just a bit now for concerts as the holiday season is officially in "crazy" mode. However, we do have a few good selections this weekend that will help work off any left-over turkey you might have lingering in your belly.

Brendan Benson is back in the area and bringing Detroit's self-proclaimed "super group" SSM with him to the Blind Pig (208 S. First St., Ann Arbor) on Friday, Dec. 2. Doors are at 9:30 p.m. and

cover is \$16 for this 18-and-up show. Check out www.blindpigmusic.com for more details.

The Gore Gore Girls will keep customers happy at the Lager House (1254 Michigan Ave. in Detroit) on Dec. 3. Keeping them company through the night will be Capitol Cities and A Thousand Times Yes! Doors are at 9 p.m. Visit www.lagerhousedetroit.com for more info.

If you were a fan of this year's best band documentary *Dig!*, you won't want to miss The Dandy Warhols at Saint Andrews Hall (431 E. Congress, Detroit) on Monday, Dec. 5. I saw them this summer at Lollapalooza and the kids are always good for some smarmy onstage comments, sometimes about their "best" friends and film co-stars The Brian Jonestown Massacre. Show time is 7 p.m. and tickets are \$17.50. Check www.ticketmaster.com for ticket availability.



Not to miss

This next concert gets its own special space because it will be a show to top shows this month. When I first heard about Beatallica, I was shocked! Shocked!

You don't really need to know anything about Metallica except for the fact that 1) the band members hate people stealing their music off the Internet and 2) they hate Napster even more.

So what would they think about Beatallica blending Metallica's musical style with Beatles lyrics? Apparently they like it, much like Mikey and his Life cereal.

Beatallica, complete with member names like "Ringo Larz," takes the mash-up concept to a different, live level. (Mash-ups recently started popping up online and feature two different songs, with similar melodies, blended into one. Think of a classier version of sampling a song. My favorite has to be a mash of the Beatles' *Paperback Writer* and the Monkees' *I'm a Believer*.)

Run for Your Life is the Beatallica track I like best. Think of those happy Beatles being given a harder, 1980s-metal sound to their lyrics. I'm not saying this stuff is outstanding, but it certainly is fun and worth a listen if you're

either a Beatles or a Metallica fan. Or even if you're a fan of both bands, but I haven't met one yet. I'm sure you can only imagine what *Blackened in the USSR* sounds like.

Beatallica's albums are free and available only on the Internet. If you're curious, check out www.beatallica.com. They'll be at Small's (10339 Conant, Hamtramck) on Thursday, Dec. 8. Visit www.smalls-bardetroit.com for more info.

On a funny note, the Milwaukee-based group was apparently served with a "cease-and-desist" order from Sony, the company that controls the Beatles' catalog of songs. Well, Lars Ulrich (the man who was all over MTV talking about how he would sue people for downloading Metallica songs) stepped in and convinced Sony to back off. Funny how things change.

P.S. Looking for nifty holiday gifts? Check out this weekend's Homemade Holiday Home Show for a variety of unique handmade trinkets, varying from sewn goodies, jewelry and even the prettiest stained glass you've ever seen. Show times are 11 a.m. to 7 p.m. Saturday and 12-5 p.m. Sunday at 36 E. Woodward Heights, Pleasant Ridge. Come early and buy a lot!

Alicia Dorset is using her free time from concerts to make lots of holiday cookies. E-mail her your favorite recipe at adorset@hometownlife.com.

Ford Community Performing Arts & Classic Productions with Detroit Public TV present:

"A WOMB 104.3" Rock & Roll Christmas Spectacular III

The Miracles #1 Hit "Tears of a Clown" & "Sloop Around"
The Vogues #1 Hit "Three Around, Look at Me"
The Shangri-Las #1 Hit "Leader of the Pack"
The Reflections #1 Hit "Just Like Romeo & Juliet"

Special Guest Star Gene Chandler "Duke of Earl"
Saturday, December 3, 2005
Show Time at 4:00 p.m. & 8:00 p.m.

Buy One Ticket, Get One Free! (A.O. Show Only)

"A MAGIC 105.1" Pre-New Years Eve Concert & Party

Starring All Award Winning Acts!

Frankie Ford #1 Hit "Sea Cruise"
Bette Midler Tribute from the Las Vegas Show
Charlie Thomas & Original Drivers #1 Hit "Under the Boardwalk" "On Broadway"

Friday, December 30, 2005
Show Time at 8:00 p.m.

at the Ford Community Performing Arts Center
 15801 Michigan Ave., Dearborn
FREE HORS' D'OEUVRES & CASH BAR!
 Prices: \$25, \$35, \$45 & \$55 (Meal & Beer for all ticket holders)
 Call the Performing Arts Box Office at **313.943.2354, Ext. 1**

LIVE ORCHESTRA!

Inside this week's

PURE ENTERTAINMENT!
filter

GANNETT

HOT TICKET - 3

Not only does the University Musical Society at the University of Michigan stay true to the original *Messiah* but the society has performed the composition since 1879

CLUBS - 5

Two of alt metal's up and coming bands are performing together at Clutch Cargo's

MUSIC - 6

The LeeVees perform a holiday show Tuesday Dec 6 at Shalom Synagogue in Farmington Hills

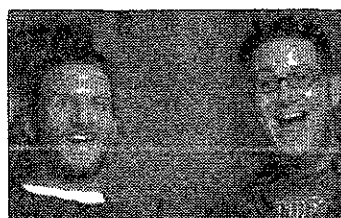

REVIEWS - 6

Jason Molina's EP showcases his musical storytelling talent

COVER STORY - 8

The Rockettes make audiences smile with precision dance and their trademark high kicks

TABLE HOPPING - 10

Check out Logan and the culinary influences from Italy Japan Thailand Morocco and Mexico incorporated onto the restaurant's menu

ART - 16

Images of rock legends are captured in a collection of photographs original art and lithographs at Oakland Mall



GET OUT - 18

Got no plans? Make some after you check out our expanded entertainment calendar of events

Observer & Eccentric
NEWSPAPERS

Ken Abramczyk
Editor

Dan Dean
Design Editor

Nicole Stafford
Staff Writer

Susan Rosiek
Executive Editor

Lana Mim
Staff Writer

Peter Neill
General Manager

Marty Carry
Advertising Director

ON THE COVER



The Christmas Spectacular features holiday music and costumes

Editorial office (248) 901 2587 / Advertising (734) 953 2153



PHOTO COURTESY OF UNIVERSITY MUSICAL SOCIETY

Jazz vocalist Dianne Reeves presents a special holiday concert Dec 10 at Hill Auditorium

An original masterpiece

UMS has performed 'Messiah' since 1879

BY NICOLE STAFFORD
STAFF WRITER

Just like there's more than one way to celebrate Christmas, there's no definitive version of George Frideric Handel's choral masterpiece and holiday classic, *Messiah*

"You'll hear all sorts of tendencies today. Ours is somewhat true to the original," said Jerry Blackstone, director of the University Musical Society Choral Union and chair of the Conducting Department at the University of Michigan School of Music

Not only does the University Musical Society stay true to the original, but the society has performed the composition since 1879

The tradition continues this year with two concerts, 8 p.m. Saturday, Dec 3, and 2 p.m. Sunday, Dec 4, at Hill Auditorium on the University of Michigan campus in Ann Arbor. The program features the UMS Choral Union and the Ann Arbor Symphony Orchestra under Blackstone's direction

Handel composed *Messiah* in just over 20 days in 1741. His best

known work, the three-part oratorio breaks down into a representation of Christ's birth, Christ's death and ultimate resurrection

Handel neither created the work with Christmas in mind nor with any thought it would enjoy enduring worldwide popularity

"I don't know that Handel envisioned that it would have the success that it has. But I'm sure that he would be very pleased," said Blackstone. "It's absolutely great music or it wouldn't have sustained the life that it has all of these years. He really does use the music to paint the text and amplify the text in a very remarkable way"

There are several reasons for the existence of so many versions and styles of the piece - from classical to gospel to jazz by ensembles of varying sizes

For one, the composition has undergone more than one transformation over the course of time. Wolfgang Amadeus Mozart did a major revision of the piece in 1788. In the 1820s, oratorios became the vogue musical form in London. Religious musical festivals presented the *Messiah* with amateurs joining the professional

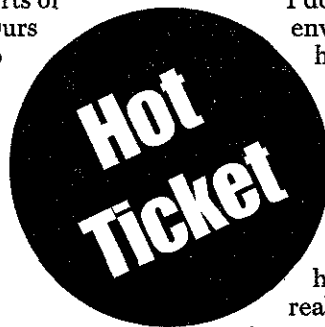

SOUNDS OF THE SEASON

What: The UMS Choral Union and Ann Arbor Symphony Orchestra perform Handel's *Messiah*

When: 8 p.m. Saturday Dec 3 and 2 p.m. Sunday Dec 4

Where: Hill Auditorium, 825 North University Avenue, University of Michigan campus, Ann Arbor

Tickets: \$10-\$30, call (800) 221-1229 or visit www.ums.org

MORE 'MESSIAH'

■ Detroit Symphony Orchestra's annual performances of Handel's *Messiah*, 3 p.m. Saturday Dec 3 and Sunday Dec 4, Orchestra Hall, Max M. Fisher Music Center, 3711 Woodward, Detroit. \$19 to \$52, call (313) 576-5111 or www.detroitssymphony.com

■ *Too Hot to Handel*, with the Rackham Symphony Choir performing a jazz-gospel version of Handel's *Messiah*, 8 p.m. Saturday Dec 17 and 4 p.m. Sunday Dec 18, Detroit Opera House, 1526 Broadway, Detroit. \$18-\$58, (313) 237-SING (7464) or www.MichiganOpera.org

PLEASE SEE **HANDEL, D12**

THE DETROIT INSTITUTE OF ARTS

The DIA's Greatest Hits

WHILE WE'RE REMODELING, WE'VE CONDENSED THE MUSEUM DOWN TO THE HITS YOU KNOW AND LOVE!

THIS WEEK'S HITS

FRIDAY, DECEMBER 2

First Friday

Experience performances by *Tiere der Nacht* (Animals of the Night), draw in the galleries, watch sculptor John Pappas at work, create your own sculptural box or take a guided tour.

Promotional support provided by **WDET 101.9FM**
a different kind of radio

SATURDAY, DECEMBER 3

Learn about the Greatest Hit of the Month—Edgar Degas' *Violinist and Young Woman*—with a museum educator.

SUNDAY, DECEMBER 4

Check out storytelling about the celebration of Kwanzaa.

Now on View: 1.877.DIA.TIXS

CAMILLE
**CAUDEL
& RODIN**
FATEFUL ENCOUNTER
OCTOBER 9, 2005 - FEBRUARY 5, 2006

Sponsored by
DAIMLERCHRYSLER

DaimlerChrysler Corporation Fund

COMPILATIONS OF ART, MUSIC, FOOD,
SHOPPING AND FUN EVERY FRIDAY NIGHT
FROM 6 TO 9 P.M. "HIT" PROGRAMS ARE FREE
WITH MUSEUM ADMISSION, UNLESS OTHER-
WISE NOTED. VALET PARKING IS AVAILABLE AT
THE WOODWARD ENTRANCE.

5200 WOODWARD AVE.
DETROIT, MI 48202
DIA.ORG

Programs are made possible with support from the Michigan Council for Arts and Cultural Affairs and the City of Detroit.

Promotional support for Friday, Nights at the DIA provided by

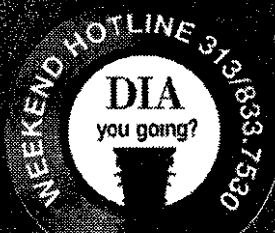

On Sale Now!



A VEE CORPORATION PRODUCTION

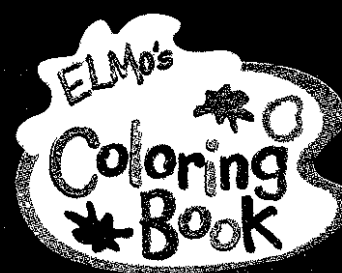

FEBRUARY 10-26

Tickets available at the Fox Theatre box office and through **ticketmaster** • 248-433-1515 • ticketmaster.com • sesamestreetlive.com



For more information call: 313-471-3099

Public TV Benefit performance
Call 313-876-8195 for more information. detroitpublictv.org



Photo: 2005 Sesame Workshop. 313/545-1000

Presenting Our
16th Annual
**JEWELRY
FESTIVAL
2005**

Thursday-Sunday
December 1-4

Opening Premiere
Thursday,
December 1st
5-9 pm

Food and
Refreshments
Served

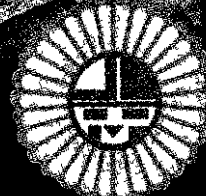
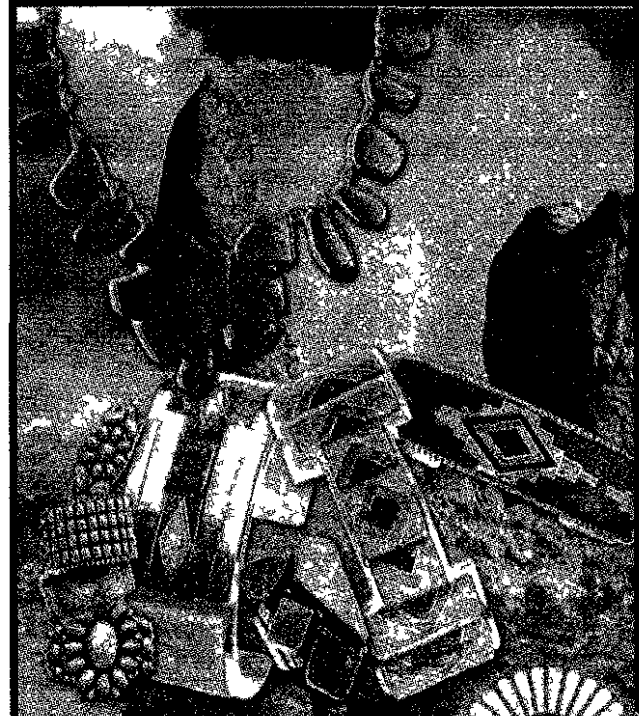

NATIVE WEST

Unique American Southwest Art
863 W. ANN ARBOR TRAIL • DOWNTOWN PLYMOUTH
734.455.8838

Photo: 313/520-0000

www.hometolife.com

A Night of Metal

As I Lay Dying, Life Once Lost perform at Clutch Cargo's

BY LANA MINI
STAFF WRITER

Clubs

Two of alt metal's most emerging bands are performing together at Clutch Cargo's, a small venue that's bound to be wild on Wednesday, Dec. 7.

As I Lay Dying and Life Once Lost will headline the show along with guests Norma Jean and Madball. For the San Diego quintet As I Lay Dying, the road has been home since day one.

They formed in 2001 and one month later, the group recorded its first album, *Beneath The Encasing Of Ashes*.

The band's success is credited to word-of-mouth by fiercely loyal fans.

As I Lay Dying began touring immediately and each tour stop gained converts. *Beneath The Encasing Of Ashes* became a hit. The second CD *Frail Words Collapse* was an underground hit. The CD contains classic Gothenburg sounds

AS I LAY DYING

Genre: Metalcore
Also performing: A Life Once Lost, Madball and Norma Jean

When: 6:30 p.m.
Wednesday, Dec. 7

Where: Clutch Cargo's, 65 E. Huron, Pontiac (248) 333-0649

Tickets: \$17. Available at all Ticketmaster outlets or by calling (248) 645-6666

emerged with its leanest, most focused effort yet, *Shadows Are Security*. All the touring we did off *Frail Words*

— the punch press rhythms, snarling vocals and melancholy riffs of seminal Swedish bands like At The Gates — blended with modern hardcore.

The endless touring plus heavy MTV requested rotation for their songs *Forever* and *94 Hours* pushed them into mainstream.

The quintet sequestered itself until spring of this year and emerged with its leanest, most focused effort yet, *Shadows Are Security*.



Metalcore band As I Lay Dying has gained a loyal underground following.

Collapse really helped us learn what songs worked in a live setting and which ones didn't, said vocalist Tim Lambesis. 'And that helped us focus on the direction of this record. There's a slower, ballad-type song *Repeating Yesterday*, but even it serves a purpose in tying the whole record together. As far as energy goes, I think all these songs are gonna be tremendous live.'

The band is Lambesis, guitarist Phil

Sgrosso, guitarist Nick Hipa, drummer Jordan Mancino and bass player Clint Norris.

While Lambesis won't label *Shadows* a full-blown "concept album," he said there's a concept and sequence.

"My lyrics have always come from a very personal perspective, but this

PLEASE SEE METAL, D15

DETROIT
OPERA HOUSE
Home of Michigan Opera Theatre
David DiChiera, General Director

The Detroit Opera House Presents

Joffrey Ballet

The Nutcracker

With LIVE accompaniment by the Michigan Opera Theatre Orchestra
Leslie B. Dunner, Conductor

Dec 1-4, 2005

ASK ABOUT THE FAMILY FUN PACKAGE
Call 313-237-SING

FREE DANCE TALK 1 HOUR PRIOR TO CURTAIN

(313) 237-SING for Tickets ... or order online at www.michiganopera.org

Thursday December 1 - 7:30 p.m.
Friday December 2 - 7:30 p.m.
Saturday December 3 - 2:00 p.m.
Saturday December 3 - 7:30 p.m.
Sunday December 4 - 1:00 p.m.
Sunday December 4 - 6:00 p.m.

Production Sponsor
BANK ONE
A Division of Morgan Chase Bank N.A.

The Detroit News Media Sponsor
0E08393476

Village Theater
AT CHERRY HILL

50400 Cherry Hill Rd. (At Ridge Road)
Canton

To purchase tickets, visit Summit on the Park Monday through Friday from 8:30 a.m. - 8:30 p.m. and Saturday and Sunday from 9 a.m. - 5 p.m. The Village Theater ticket office will be open one hour prior to each performance.

To purchase tickets by phone, call 734-394-5460. For more information about the theater and to view the complete schedule, please visit www.cantonmi.org/CPAFC/about.asp.

MARY LEE O'BRYAN (Café DIA Series)
Explore art from cultures throughout the world that addresses illness and healing.
December 3 • 11:45 a.m.
\$15 (food & beverage included)

AN EVENING WITH THE STARS
Sponsored by Uptown in Canton
Join us for a "star studded" musical evening where you'll swear you're watching the real thing!
The All-Star Line-Up includes: Jack Nicholson • Tina Turner • Barry Manilow • Barbara Streisand • Johnny Mathis • Lou Rawles • Neil Diamond • Diana Ross • Ray Charles.
December 30 • 8 p.m.
\$25

Robin Spielberg's "Piano Stories"
January 6 • 8 p.m. \$25/\$15

EVOLA MUSIC PRESENTS:
Neil Donato
January 8 • 4 pm \$15/\$12

Andrew Song-Classical Piano Concert
January 25 • 8 p.m. \$15/\$12

Dimas Carabello Piano & Dance
January 27 • 8 p.m. \$15/\$12

0E08393476

'Hanukkah Rocks'

The LeeVeEs offer humorous, but serious, holiday music

BY LANA MINI
STAFF WRITER

There aren't too many popular Hanukkah songs. Adam Sandler's fun *Happy Hanukkah* is the only one in the mainstream.

But The LeeVeEs are hoping to change that with their new CD *Hanukkah Rocks*.

And they're performing a holiday show at 7 p.m. on Tuesday, Dec. 6, at Shalom Synagogue, 29901 Middlebelt Road in Farmington Hills.

The band is also on a national tour with the Bare Naked Ladies, which could really help push The LeeVeEs career.

The LeeVeEs is a Hanukkah-related spin-off project from Adam Gardner of the band Guster and Dave Schneider of the Zambonis. While the songs are fun, the musicians are skilled.

"We take our Hanukkah music very seriously, but the record is full of humor," Schneider said. "By all means we laugh at ourselves and we'll gladly laugh along with anyone else as long as they buy the CD."

The singers like to joke.

The CD, available at most major music stores includes songs like *Latke Clan*, *Applesauce vs. Sour Cream*, and *How do you spell Chanukkahhh?* (sic). The style on the CD is wide including The Ramones-inspired *Gelt Melts* with silly lyrics like "If guys can eat a chocolate bunny why can't we eat chocolate money?" Another song is Hawaiian-style about a retiree who longs to be in Florida at *The Timeshare*.

In the melodic style of The Gusters and Zambonis, the



The LeeVeEs are on tour performing the *Hanukkah Rocks* CD.

musicians have put together a full band for the tour.

While Jewish songwriters like Irving Berlin wrote only Christmas songs, these two want their songs as popular as Berlin's.

The idea for the CD came quite simply.

Earlier this year the Zambonis and Guster toured together. On a bus while driving from St. Louis to Denver, Gardner and Schneider discussed writing some songs together "only about Hanukkah." Seconds later they started strumming on their acoustics and within an hour had the Beach Boys-style song *Latke Clan*.

When the duo approached producer friend Peter Katis (Interpol, Get Up Kids) to record the music, he was uncertain. "This has a lot of potential of being stupid," Katis had said.

Then he realized the songs weren't just novelty, but were musically strong with organized arrangements.

Tickets for the LeeVeEs' show are \$15 general admission. A \$25 patron ticket includes VIP status and meet-and-greet with the band. Tickets can be purchased at Adat Shalom or by calling (248) 851-5100.

Molina continues his superb storytelling on new EP

BY STEPHANIE TARDY
STAFF WRITER

Hard to Love a Man EP

The Magnolia Electric Co.
Secretly Canadian

If you wish that new *My Morning Jacket* record wasn't so "arty"

An EP, you say? Why, yes. Sometimes there are artists so great that you must

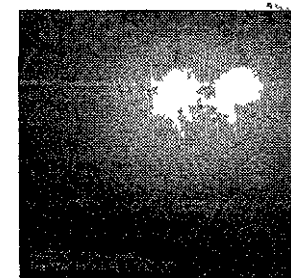

devour everything they put out. In this case the artist is Jason Molina, the singer and songwriter behind The Magnolia Electric Co.,

who used to call his band of rotating players Songs Ohia. Both groups center around Molina's striking ability to tell a story. Like a troubadour. Or a singer songwriter. And, all together, not a whole lot unlike Neil Young or Will Oldham.

This EP sees more of what followers of Molina love — there is a pounding chorus, over here an at-country esque guitar solos and, oops there is it again, that wonderful storytelling. Really, that is the key to understanding why I'm writing about an EP. Superb musical storytelling — got it? OK. Good. Moving on.

The Magic Numbers
Self-titled

EMI

Download now *Love Me Like You* in this review. I take it to the man.

Gah! Why did everyone tell me The Magic Numbers were like The Mamas

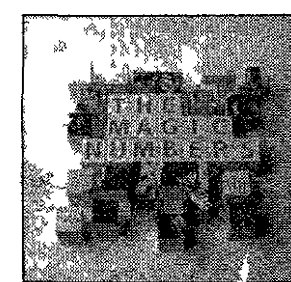

and The Papas meets Mates of State?

I could hear how you could say that in the first half of the album, maybe. But by the second

half, it becomes clear — um, hello people. This is Ben Harper sung by a brother-sister duo. They get points for playing a melodica, which for the uninitiated is

PLEASE SEE REVIEWS, D15

www.hometownlife.com

Congratulations



to winners of

Lunch With Santa

December 4, 2005
Rock Financial Showplace

KAMERON RICHARDSON

MATHEW BRENTON

RAYLEEN MORGAN

ASHLEY BOWDEN

THE
Observer & Eccentric
NEWSPAPERS

WHERE HOMETOWN STORIES UNFOLD

OE08392580 EPS

Great Holiday Gifts!

All Holiday Ornaments 10% OFF
Now thru 12-24-05

The Glassworks STUDIO & GALLERY
Continuing the tradition of hand-blown glass in Plymouth.

543 Deer Street
Downtown Plymouth
(734) 459-6419

One block east of Main Street and 1/2 block south of Kellogg Park in Downtown Plymouth

Kick Up Your Heels & Celebrate The Holidays With Us!!!

Menopause The Musical®



The Hilarious Celebration of Women and The Change!

★ Gift certificates available ★

THE GEM THEATRE • 333 Madison Ave., Downtown Detroit • Box Office 313-963-9800

Ticketmaster 248-445-6466 • Ask about our Inclusive Restaurant Packages • www.gemtheatre.com • www.menopausemusical.com



OE08392580

Filter

In your paper every Thursday!

PURE ENTERTAINMENT!

Skating is Really "Cool!"

The Rink

CAMPUS MARTIUS PARK

- Group Rates/ Holiday Field Trips
- Family Outings/Private Ice Parties
- Open 7 Days Including All Holidays
- Convenient Adjacent Parking
- Skate Rentals

NOW OPEN!

HOURS M-TH 11 AM 10 PM
 FRI 11 AM MIDNIGHT
 SAT 10 MIDNIGHT
 SUN NOON 8 PM

Located at Detroit's Meeting Place~the Crossroads of Downtown Detroit
 800 Woodward Avenue
 Across from the Compuware Building and the Hard Rock Cafe
 For reservations & further info, call 313-963-9393

EST. 1969

Ground Round

GRILL & BAR

Holiday Shoppers - Get 15% off your bill at the Ground Round in Livonia if you show any holiday shopping receipt.

Discount valid toward the first \$50 of your food bill. Not valid with any other offer or special. Does not include tax, gratuity or alcohol. Offer expires December 31st 2005.

17050 Laurel Park South • Livonia
 Just Off the Southeast Corner of Newburgh and 6 Mile
(734)462-1735
 Private Rooms Available

OE08392020

Dreidel Will Rock

THE LEEVEES

IN CONCERT
 Tuesday, December 6
 7 p.m.
 Adat Shalom Synagogue

with **SHERE**

Adat Shalom is pleased to present
 The LeeVeers
ONLY MICHIGAN APPEARANCE

The LeeVeers
 Guster's Adam Gardner and the Zambonis' Dave Schneider have put together a new album of songs called "Hanukkah Rocks."

General Public, \$15.
 Patron Ticket, \$25 (includes meet-and-greet with the band)
 Tickets are available at Adat Shalom during weekday business hours and on Sunday mornings. For information, call 248-851-5100 or visit www.adatshalom.org.

KICK IT UP

RADIO CITY ROCKETTES BRING THEIR GLAMOUR TO DETROIT

STORY BY LANA MINI | STAFF WRITER



They're back with their white dresses, long legs and red lips. The perfect dancers of the Radio City Rockettes have kicked off their annual tradition of performing throughout the Christmas season at the Fox Theatre.

The Radio City Christmas Spectacular is performed every day except Mondays through Christmas Eve and Detroit is just one of nine cities nationwide lucky enough to host the shows.

The Christmas Spectacular features a cast of 140 including 36 Rockettes, glamorous costumes, and holiday music. As always, the Rockettes make audiences smile with precision dance and their trademark high kicks. And as always Santa Claus makes his special appearance from the North Pole.

To help get you into the *Spectacular* mood we've compiled what we think are some interesting Rockettes facts. Enjoy!

■ If you're a young dancer and dream of being a Rockette someday you can fly to New York and take a three-hour Rockette Experience workshop, from a Rockette, and even try a mock audition. That's for dancers ages 10 and older who have training in jazz, tap and ballet. For more information, call (212) 631-4354.

■ There's even more intensive studying opportunities during summer months where dancers can train for five days, six hours a day, and learn Rockette jazz, tap, kick lines and more. That's held at Radio City Music Hall in July.

You must be 14 years old with at

PLEASE SEE ROCKETTES, D12

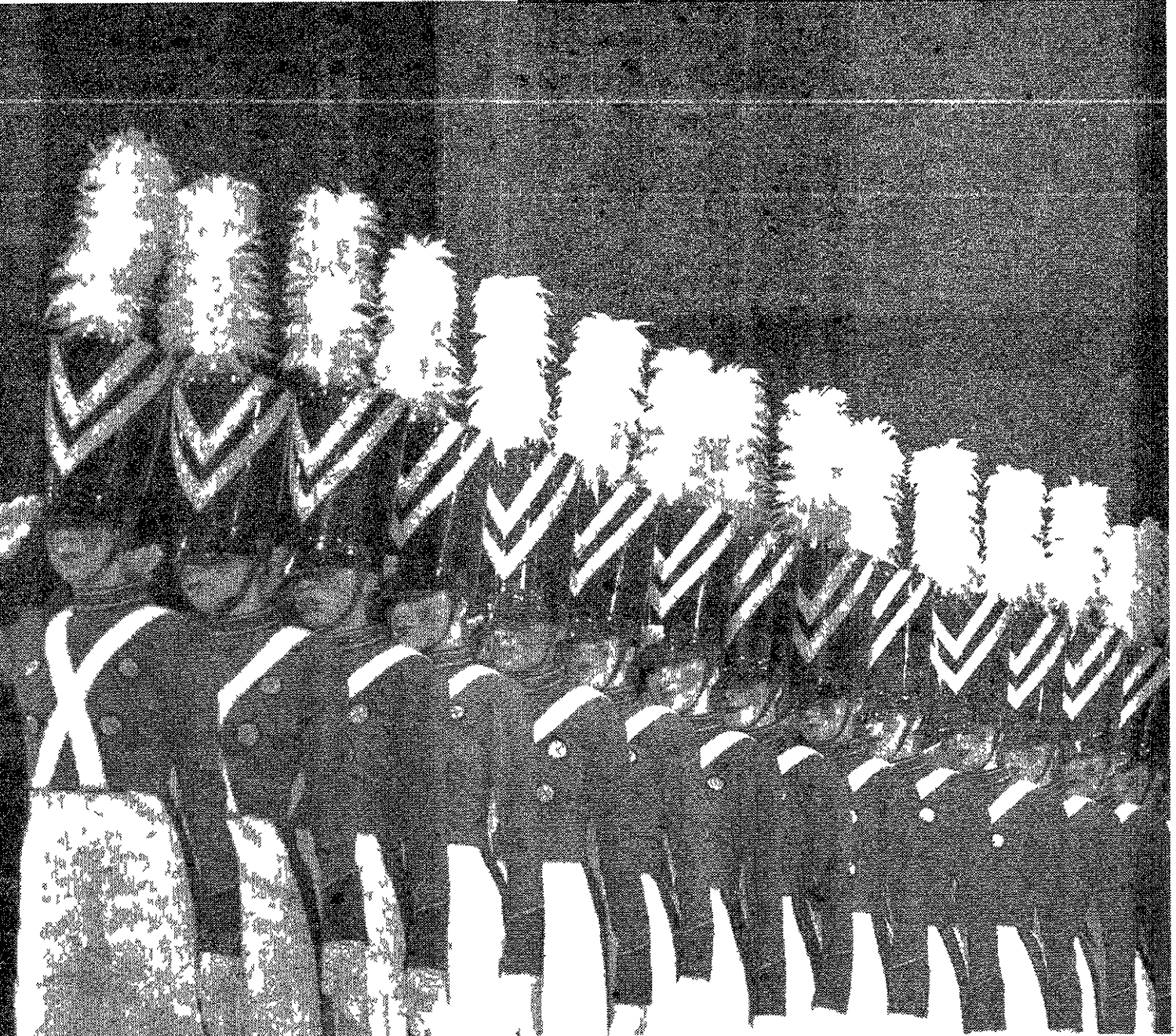

The Rockettes perform every day except Mondays, through Christmas Eve. At top, their costumes have been hiked up over the years but the precision high kicks remain the same.

Your donation gives me warm winter clothes.

With your support,
The Salvation Army helps protect
struggling families from the cold
— and so much more. Thousands of
Metro Detroiters face poverty every
day. Let's make change happen right
here at home.

MAKE
*Change*SM
HAPPEN 



1-877-SAL-MICH

Donate at any LaSalle Bank or at WJR's Virtual Red Kettle at wjr.com

LaSalle Bank
ABN AMRO





BILL BRESLER | STAFF PHOTOGRAPHER

Broiled mussels with apple wood smoked bacon, halloumi cheese, served on a bed of braised cabbage, with a stained glassed sauce composed of citrus reduction, chili and parsley oils

Global influences headline Logan's menu

BY ELEANOR HEALD
CORRESPONDENT

Open just over a year, the 50-seat Logan in Ann Arbor is a must if you've not discovered it.

Chef Thad Gillies, formerly of Zingerman's with kitchen stunts in Manhattan at no-ables such as Union Square Cafe and Lespinasse, partnered with his brother Ryan Gillies and Kevin Hobart in Logan.

They've sub-titled it "An American Restaurant," yet food influences from Italy, Japan, Thailand, Morocco and Mexico create diversity and singular, delicious flavors.

All accented by the small bar's chartreuse back wall, white table cloths add crispness against a bright apricot side wall with colorful, abstract wall art, created by Chef Thad's wife, artist Ann Turner.

SMALL MENU - BIG FLAVORS

A short core menu consists of

seven appetizers and 11 entrees but mouth-watering descriptions make final decisions difficult.

Among appetizers, two are salads: Shaved Fennel in a shallot and Parmesan vinaigrette, garnished with a balsamic glaze and Parmesan chips, and Logan Salad with baby greens, tossed with a 30-year-old sherry vinaigrette and sprinkled with crispy garlic chips.

Fresh East Coast Broiled Mussels with apple wood smoked bacon and halloumi cheese is served on a bed of braised cabbage with a stained glass sauce, composed of citrus reduction, parsley and chili oils.

Not only are the mussels delicious, the edible "stained glass" pastry is amazing.

Ginger and shallot seasoned Chinese Pork Dumplings may read like an appetizer on any Asian menu but their presentation on a bed of cilantro with a tamarind infused tomato sauce, elevates them to gourmet status.



LOGAN

Where: 115 W Washington Ann Arbor (734) 327 2312

Open: Tuesday Saturday 5 10 p m

Food style: Globally influenced menu with the right touch of regional America

Cost: Appetizers \$8 \$12 Main courses \$22 \$32 Two item kids menu \$3 (mac and cheese) and \$6 (crispy chicken breast)

Reservations: recommended

Among my favorite main dishes are melt-in-your-mouth Braised Oaxacan Short ribs, braised in an authentic Oaxacan mole with plantain confit and epazote-herbed black beans, a country spin called Spanish Paprika Osso Buco, and Thai Scallops in a traditional Thai coconut sauce, served with mashed potatoes and pickled mustard greens with crispy shallots.

Glazed Skate Wings is the most non-traditional seafood offering. Glazed with a citrus reduction,

PLEASE SEE **LOGAN, D11**

ALL-YOU-CAN-EAT

PASTA

Buffet

**5 pm-9 pm
Every Friday &
Saturday through
December 17th**

\$8.95

**Spaghetti, Fettuccini, or Bow Tie Pasta
with your choice of Four Delicious Sauces:
Meat Sauce, Alfredo, Marinara, or Pesto Cream**

**Dinner includes: Green Bean Almondine,
Garlic Bread Sticks *Plus*
All-You-Can-Eat-Soup & Salad Bar**

Great American
Grubs

**Hilton
Garden Inn
Plymouth**

**14600 N. Sheldon Rd.
Plymouth, MI 48170
734-354-0001**

GRAND OPENING

Millennium Psychic Readings by Susan

- Tarrot Cards • Palms
- Tells past, present & future
- Spiritual Therapy
- Aura Cleansing
- Advice on Love, Health, Business & Career

All Readings Private & Confidential

Available for Private Parties

- Call for appointment

**Open 7 Days:
Mon-Sat 110am-110pm
Sun 110am-6pm**

**896 Penniman
Downtown Plymouth
734-674-7178**

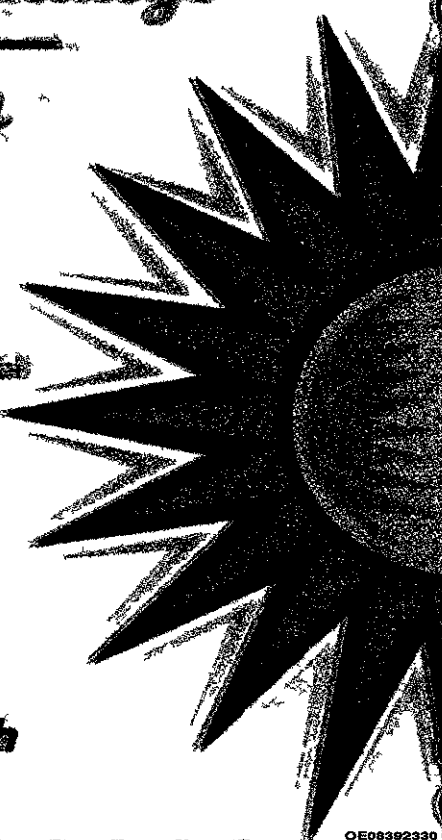

LOGAN

FROM PAGE D11

garnished with crispy capers and served with fingerling potato and wild mushroom hash, it doesn't get better at an oceanside restaurant

Woodford Reserve, Spanish paprika, honey and Dijon mustard are marinating ingredients for Bourbon Pork Tenderloin, served with a potato gratin, poached pears and herbed pork reduction

EXTRAS

A short, creative, sensibly-priced wine list, maintained by partner Kevin Hobart, complements the menu's inventive dishes

Made-on-premise desserts complete a dining experience at Logan. Order the cookies if not to eat in, then to take out!

Eleanor Heald is a nationally published writer and Troy resident who writes about restaurants, food, wine and spirits for the *Observer & Eccentric Newspapers*. Contact her by e-mail at focusonwine@aol.com

Please recycle
this newspaper



FARMINGTON HILLS

Gala, A New American Bistro

Where 33316 Grand River Farmington (248) 478 2355

Open Monday Thursday 11 a.m. to 10 p.m. until midnight Friday Saturday noon to midnight

Food style Fresh American ingredients prepared to order for Euro and Asian inspired dishes

Cost Small plates \$4-\$14

Reservations recommended
No handicap access to lower level location

NORTHVILLE TOWNSHIP

P.F. Chang's China Bistro 17905 Haggerty Road (248) 675 0066 Stylized Chinese dining in a contemporary casual atmosphere with high energy Asian feel Vegetarian friendly

Reservations recommended

Other locations 2801 West Big Beaver Rd (Somerset Collection South) Troy (248) 816 8000 and 2425 Lake Lansing Rd (Eastwood Town Center) Lansing (517) 267 3833

PLYMOUTH

Fiamma Grille

380 S. Main Street (734) 416 9340

5-11 p.m. Tuesday Thursday Friday and Saturday until midnight Italian accented steak and seafood grill

Cost \$22 average main course
Reservations recommended

SOUTHFIELD

Etouffee

25333 W 12 Mile (in Star Southfield Entertainment Centre) (248) 750 0700
11 a.m. to 10 p.m. Monday Wednesday until midnight Thursday and until 1 a.m. Friday 5 p.m. to 1 a.m. Saturday 3-9 p.m. Sunday Creole Cajun barbecue and Southern Main courses and barbecue under \$20 Kids' menu \$5
Reservations Recommended
Entertainment Thursday Friday and Saturday evenings

TROY

Bon Vie Bistro & Wine Bar

2810 Big Beaver Road (second-level Somerset Collection South near the Skywalk) (248) 458 2114 Monday Thursday 11 a.m. to 9 p.m. Until 10 p.m. on Friday Saturday 10:30 a.m. to 7:30 p.m. Sunday 10:30 a.m. to 7 p.m. French Lunch main dishes \$10-\$15 Dinner \$14-\$24

Reservations recommended

Brio Tuscan Grille

2801 W Big Beaver Rd in Somerset Collection South (248) 643 6045 Tuscan featuring grilled steaks and chops Check average at lunch \$11-16 dinner \$20-27

WEST BLOOMFIELD

Sea Grille

6199 Orchard Lake Road West Bloomfield (248) 487 0326

Lunch Monday Friday 11:30 a.m. to 2:30 p.m. Saturday and Sunday lunch/brunch menu noon 4 p.m. Dinner Sunday Thursday 5:10 p.m. and until 11 p.m. Friday and Saturday Bar menu available between lunch and dinner daily Contemporary seafood with other appealing internationally inspired food options

Lunch most items under \$10 Dinner most main courses under \$20
Reservations recommended

16th Anniversary Season
The Michigan Classic
Ballet Company
presents
The Nutcracker
Ballet

Saturday, December 10th
11 a.m. and 3:30 p.m.

Sunday, December 11th
3 p.m.

Reserved Seating
Adults • \$18
Children & Seniors • \$14

Nutcracker Tea
Sunday, December 11th
1:30 p.m. • \$10

Mercy Auditorium
29300 W. 11 Mile Rd.
Farmington Hills
Group tickets available

For Ticket Information or to charge by phone 248-334-6964

0E08389298

www.hometownlife.com

GRECIAN CAFE

Family Restaurant
OPEN 24 HOURS
A TASTE OF GREEKTOWN
AND SO MUCH MORE
IN PLYMOUTH
413 N. Main Street
Full Carry-Out
Service Available
734-455-7887
CLOSED 3 P.M. SUN. to 6 A.M. MON.

BREAKFAST SPECIAL	ANY MEAL SPECIAL	DINNER SPECIAL
<p>Mon-Fri • 6-10 a.m. 2 Eggs 3 Pieces of Meat (ham, bacon or sausage) Hash Browns, Toast & Jelly \$1.99 With this coupon Expires 1-5-06</p>	<p>10% off Your Entire Bill With this coupon Not valid with any other offer Expires 1-5-06</p>	<p>Buy 1 Dinner Entree, Get the 2nd Dinner Entree 50% off With this coupon Not valid with any other offer Expires 1-5-06</p>

ROCKETTES

FROM PAGE D8

least five years training in tap, jazz and ballet For details, e-mail rocketteeexperience@radiocity.com or call (212) 631 4330

■ Designers who have created costumes

THE ROCKETTES RADIO CITY CHRISTMAS SPECTACULAR

Where: Fox Theatre
Tickets: \$20 \$100 at all Ticketmaster and Olympia Entertainment outlets including all Marshall Field's and Hockeytown Authentics in Troy
When: Tuesdays and Sundays through Christmas Eve Dec 24
Times: Vary
For details, visit: www.ticketmaster.com call (248) 645-6666 visit www.olympiaentertainment.com or call (313) 471 3099

a porcelain doll The costume was originally made from lined duvetine jackets and cotton duct pants and were stiffened with starch The costume design has remained unchanged since 1933 except today cotton twill is used, but it's still bleached and starched for a rigid effect

■ The Rockettes costumes remained true to their traditional

Four win Rockettes tickets

Four families will enjoy seeing a performance of The Radio City Rockettes and The Radio City Christmas Spectacular at the Fox, courtesy of the *Observer & Eccentric Newspapers*

Simone Frazier of Rochester Hills, Landa Luna of Plymouth, Maureen Postler of Livonia and Mark Kovach of Sterling Heights each won a four-pack of tickets to see an upcoming performance Contestants were required to write and tell why they, their family and friends return to watch the show every year Simone, 8, wrote that he wanted to do

leggy style yet have become shorter over the years

In the 1930s and 1940s the dancers wore trunks But costumes became sassier when bikinis became popular In the 1960s the length became even shorter

■ In 1999, two new costumes were introduced Both are contemporary ■ Each dancer changes costume eight times during a show They have about 80 seconds to do so

■ Since 1933 only a few hundred women have claimed a Rockettes title

■ The Detroit version has been tailored to match the opulence of Fox Theatre Extra light bulbs and other sparkles have been added to the scenery

■ They also search for candidates no shorter than 5 feet, 6 inches and no

"something special for his Nana' who bought tickets for the show every year Luna said her daughter first saw The Rockettes do high kicks when she was 8, and now she is in her second year on the Plymouth Pom team

Kovach wrote about how thrilled his daughter was to meet a Rockette during intermission at a show about five years ago Postler remembered how great of an experience the show was and was amazed see the joy in the audience, particularly the children

Congratulations to the winners!

taller than 5 feet 10

On stage, the tallest girls are placed in the middle and the shortest are placed on the ends to create the illusion of equal height among all dancers

■ The dancers entertained troops in World War II, performed at the Macy's Thanksgiving Day parades and for the 2001 Presidential Inauguration The live shows are seen annually by 2.1 million people

■ Created by Russell Markert in 1925 and originally called the Missouri Rockets, the dance troupe is considered one of the world's most famous precision dance teams that has kicked its legs and tapped its way to prestigious events nationwide

HANDEL

FROM PAGE D3

choir, resulting in large ensemble presentations quite unlike what Handel had in mind

By the 1880s, a movement to perform *Messiah* as Handel intended began, but with so many transformations, "who knows what the original version was?" said Blackstone

UMS incorporates modern instruments and makes use of a large 220-voice chorus

But we try to do it with crispness and clarity and thoughts of Baroque music, said Blackstone

Another reason for the proliferation of so many versions of *Messiah* Its status as a holiday tradition embraced by many

"It's become a holiday tradition across the world," said Blackstone "And, it's been around so long, and it's been sung so often that we just know it"

JAZZY CHRISTMAS

What: University Musical Society also hosts jazz vocalist Dianne Reeves performing Christmas Time is Here

When: 8 p.m. Saturday Dec 10

Where: Hill Auditorium 825 North University

Avenue University of Michigan campus Ann Arbor

Tickets: \$10 \$48 call (800) 221 1229 or visit www.ums.org

This Holiday Season,
Find Out How To Ruin A Great Friendship.

"You'll laugh from beginning to end."
 Jim Ferguson, ABC-TV

just friends

PG-13 PARENTS STRONGLY CAUTIONED
 Some Material May Be Inappropriate for Children Under 13
SEXUAL CONTENT INCLUDING SOME DIALOGUE

NOW PLAYING

AMC FORUM 30 586 254-5663	MJR MARKETPLACE CINEMA 20 586 264-514	STAR GRATIOT at 15 MILE 586 791 3420	UA COMMERCE STADIUM 14 248 960-5980	AMC LAUREL PARK 248-462 6200	MJR SOUTHGATE 20 734-284-3456	STAR GREAT LAKES CROSSING 248-454-0366	UPTOWN PALLADIUM 12 248 944-F LM	AMC LIVONIA 20 734-542-9909	PHOENIX WEST RIVER 248-788 6872	STAR JOHN R at 14 MILE 248-565 2070	CANTON 7 734-98 1900	SHOWCASE WESTLAND 734-729 1080	STAR ROCHESTER HILLS 248-853 2260
------------------------------	--	---	--	---------------------------------	----------------------------------	---	-------------------------------------	--------------------------------	------------------------------------	--	-------------------------	-----------------------------------	--------------------------------------

NO PASSES OR D SCOUNT COUPONS ACCEPTED.

For More Information About This Movie
www.justfriendsmovie.com MovieFane.com

"A MAJOR MOVIE EVENT!"
 PETE HAMMOND, MAXIM

No Day But Today
RENT
 IN MOVIE THEATRES

PG-13 PARENTS STRONGLY CAUTIONED
 Some Material May Be Inappropriate for Children Under 13
 MATURE THEMATIC MATERIAL, DRUG USE, LANGUAGE, AND SOME STRONG LANGUAGE

NOW PLAYING

PHOENIX THEATRES AT BEL-AIR CENTRE 313/438-3494	EMAG NE CANTON 734/72 3456	AMER CAN FAMILY C. NEMAS DOWNTOWN RIVERFRONT 4 259 2370	STAR THEATRES GRATIOT 586/791-3420	AMC LAUREL PARK 10 734 462-6200	EMAGINE NOW 248/319 FILM	MJR SOUTHTRATE 20 734/284-3456	PHOEN X THEATRES WEST RIVER CENTRE 248/788 6572
SHOWCASE C NEMAS BEACON EAST CINEMAS 313/882 7500	UNITED ARTISTS COMMERCE STADIUM 14 248/966-5801	STAR THEATRES FAIRLANE 313/240-6389	STAR THEATRES GREAT LAKES CROSSING 248/454-0366	LIVONIA 20 734/542 9909	STAR THEATRES ROCHESTER HILLS 248/853-2260	STAR THEATRES TAYLOR 734/287 2200	SHOWCASE CINEMAS WESTLAND 1-B 734/729 1080
UPTOWN BIRMINGHAM 8 248/644 FILM	SHOWCASE C NEMAS DEARBORN 1-9 3 3/56 3448	AMC FORUM 30 586/254-5663	STAR THEATRES JOHN-R 248/585 2070	MJR MARKET PLACE CINEMA 20 586/264 1514	STAR THEATRES SOUTHFIELD 248/372 2222	Sorry No PASSES Accepted For This Engagement For Additional Information Call 1-800-368-0000	

Guide

Where available by deadline, features and times are listed.

Call your local theatre for showings for this week. Check listings below for phone numbers and websites

THE
Observer & Eccentric
NEWSPAPERS

PHOENIX THEATRES AT BEL-AIR CENTRE DETROIT'S NEIGHBORHOOD THEATRE

For Group Sales Special Events & Field Trips
PLEASE CALL 248-788-5785

Tickets Now On Sa e Today Harry Potter & The Goblet Of Fire Chron e o Ma ne

To 12/01/05

IN THE MIX PG 13

15 12.5 12.50 1.35 2.30 3.0 3.50 4.50

5.30 6.10 7.00 7.50 8.30 9.20 0.05 0.45 1.35 12.15 2.30

GET RICH OR DIE TRYIN' (R)

1.30 12.30 2.00 3.00 4.40 5.40 7.15 8.15 9.50 10.50 2.30

RENT PG 13

00 45 4.25 7.20 10.00 2.30

HARRY POTTER AND THE GOBLET OF FIRE PG 13

2.00 1.0 3.20 4.30 6.45 7.45

GOBLET OF FIRE

9.45 0.55 2.30

ZATHURA PG

11.00 AM

THE ICE HARVEST R

1.50 2.20 5.50 0.0 2.25

WALT DISNEY'S CHICKEN LITTLE G

15.10 3.5 5.5 15.70 5.90 0.0

SAW II R

0.45 2.30

IN HER SHOES (PG 13) 10-15 pm

JARHEAD (R)

12.20 pm | 0.30 pm | 03.15 pm | 04.40 pm | 06.35 pm |

07.45 pm | 09.45 pm | 0.40 pm

NORTH COUNTRY (R)

2.25 pm | 06.20 pm

PRIME (PG 13)

35 am | 02.05 pm | 04.35 pm | 07.0 pm | 09.50 pm

SAW II (R)

2.5 pm | 01.15 pm | 02.30 pm | 03.30 pm | 04.45 pm

05.45 pm | 07.25 pm | 08.5 pm | 09.40 pm | 0.30 pm

SHOPGIRL (R)

55 am | 02.45 pm | 05.20 pm | 07.55 pm | 0.25 pm

THE FOG (PG 13)

06.45 pm | 09.05 pm

THE LEGEND OF ZORRO (PG)

2.55 pm | 03.55 pm | 06.55 pm | 09.55 pm

THE WEATHER MAN (R)

11.45 am | 02.25 pm | 04.55 pm | 07.35 pm | 10.05 pm

WALLACE & GROMIT: THE CURSE OF THE WERE RABBIT (G)

1.35 am | 01.55 pm | 04.20 pm

ZATHURA (PG)

40 am | 12.30 pm | 01.30 pm | 02.0 pm | 03.0 pm

04.10 pm | 04.50 pm | 05.50 pm | 06.50 pm | 07.30 pm

08.30 pm | 09.20 pm | 10.20 pm

Starts Friday

HARRY POTTER AND THE GOBLET OF FIRE (PG 13)

10.00 am | 0.30 pm | 05.00 pm | 08.30 pm | 12.00 am

Star John R at 14 Mile

32289 John R Road

248-885-2070

On line at www.fandango.com

12/01/05

Chicken Little (G)

01.20 pm | 03.20 pm | 06.10 pm | 08.20 pm | 0.35 pm

DERAILED (R)

0.0 pm | 03.50 pm | 06.20 pm | 09.00 pm

Get Rich or Die Tryin' (R)

02.00 pm | 04.45 pm | 07.45 pm | 0.25 pm

Harry Potter and the Goblet of Fire (PG 13)

2.00 pm | 12.40 pm | 0.50 pm | 03.0 pm | 03.55 pm

6.00 pm | 06.45 pm | 07.10 pm | 09.00 pm | 0.30 pm

In the Mix (PG 13)

2.0 pm | 02.40 pm | 05.00 pm | 07.20 pm | 09.40 pm

Jarhead (R)

10.00 pm

Just Friends (PG 13)

2.40 pm | 03.00 pm | 05.30 pm | 08.00 pm | 0.10 pm

Pride and Prejudice (PG)

2.00 pm | 03.30 pm | 06.40 pm | 09.30 pm

RENT (PG 13)

2.20 pm | 03.40 pm | 07.10 pm | 0.25 pm

Saw II (R)

0.00 pm

The Ice Harvest (R)

12.20 pm | 02.50 pm | 06.05 pm | 08.15 pm | 10.20 pm

Walk the Line (PG 13)

12.00 pm | 0.00 pm | 03.05 pm | 04.00 pm | 06.00 pm

Yours Mine and Ours (PG)

01.40 pm | 04.20 pm | 06.50 pm | 09.20 pm

Zathura (PG)

1.50 am | 02.0 pm | 04.35 pm | 07.30 pm

Star Rochester Hills

200 Barclay C Co

248-853-2260

STUDENT DISCOUNT NOW AVAILABLE WITH VALID SCHOOL ID

1.35 am | 01.40 pm | 04.40 pm | 06.35 pm | 08.30 pm

Chicken Little (G)

01.10 pm | 03.40 pm | 06.15 pm | 08.45 pm

Harry Potter and the Goblet of Fire (PG 13)

2.10 pm | 03.0 pm | 04.00 pm | 06.35 pm | 07.5 pm

Jarhead (R)

08.00 pm | 0.45 pm

Just Friends (PG 13)

12.20 pm | 02.45 pm | 05.20 pm | 07.45 pm

Pride and Prejudice (PG)

2.40 pm | 03.50 pm | 06.55 pm | 09.40 pm

RENT (PG 13)

01.20 pm | 04.20 pm | 07.25 pm | 10.30 pm

Walk the Line (PG 13)

1.55 am | 03.00 pm | 06.00 pm | 09.05 pm

Yours, Mine and Ours (PG)

02.00 pm | 04.55 pm | 07.05 pm | 09.25 pm

Zathura (PG)

12.50 pm | 03.20 pm | 05.40 pm

Harry Potter and the Goblet of Fire (PG 13)

2.00 pm | 2.40 pm | 0.20 pm | 02.00 pm | 02.46 pm |

03.20 pm | 04.00 pm | 04.40 pm | 05.20 pm | 06.00 pm |

06.50 pm | 09.00 pm | 06.45 pm | 09.20 pm | 10.10 pm

In the Mix (PG-13)

12.20 pm | 01.30 pm | 03.10 pm | 04.0 pm | 05.40 pm

06.30 pm | 08.20 pm

Jarhead (R)

01.40 pm | 04.50 pm | 07.50 pm | 10.35 pm

Just Friends (PG 13)

0.50 pm | 04.30 pm | 07.0 pm | 09.30 pm

RENT (PG 13)

2.50 pm | 02.30 pm | 03.50 pm | 06.10 pm | 07.00 pm

Saw II (R)

09.0 pm | 0.00 pm

The Ice Harvest (R)

07.25 pm | 09.45 pm

Walk the Line (PG 13)

02.10 pm | 04.20 pm | 06.35 pm | 09.00 pm

Yours Mine and Ours (PG)

12.30 pm | 03.30 pm | 06.30 pm | 07.30 pm | 09.50 pm

Zathura (PG)

12.10 pm | 0.0 pm | 02.30 pm | 03.40 pm | 05.00 pm

06.20 pm | 07.20 pm | 08.30 pm | 09.40 pm

Star Fairlane

8900 M h gan Ave Dearborn

313-240-6389

CALL THEATRE FOR UPDATED INFORMATION

12/01/05

Chicken Little (G)

0.35 am | 2.0 am | 2.45 pm | 0.40 pm | 02.50 pm

03.45 pm | 05.00 pm | 06.05 pm | 08.20 pm | 10.40 pm

DERAILED (R)

2.55 pm | 03.30 pm | 06.0 pm | 08.55 pm

Get Rich or Die Tryin' (R)

12.35 pm | 03.25 pm | 06.45 pm | 08.0 pm | 09.35 pm

Harry Potter and the Goblet of Fire (PG 13)

10.30 am | 1.00 pm | 5.5 am | 2.40 pm | 0.30 pm

02.00 pm | 02.40 pm | 03.35 pm | 04.20 pm | 05.0 pm

05.45 pm | 06.5 pm | 07.5 pm | 08.00 pm | 08.50 pm

In the Mix (PG 13)

2.05 pm | 01.10 pm | 02.30 pm | 03.55 pm | 05.2 pm

06.35 pm | 07.50 pm | 09.10 pm

Jarhead (R)

50 am | 03.05 pm | 06.00 pm | 09.00 pm

Just Friends (PG 13)

1.40 am | 02.20 pm | 04.50 pm | 07.40 pm | 0.20 pm

RENT (PG 13)

12.5 pm | 01.55 pm | 03.40 pm | 07.05 pm | 0.0 pm

Saw II (R)

1.0 am | 0.45 pm | 04.30 pm | 07.25 pm | 09.55 pm

The Ice Harvest (R)

1.30 am | 02.0 pm | 04.40 pm | 07.30 pm | 09.45 pm

The Legend of Zorro (PG)

0.00 pm | 04.05 pm | 07.00 pm | 0.0 pm

Walk the Line (PG 13)

11.45 am | 03.0 pm | 06.25 pm | 09.25 pm

Yours Mine and Ours (PG)

2.30 pm | 03.00 pm | 05.40 pm | 07.55 pm | 10.05 pm

Zathura (PG)

10.50 am | 01.20 pm | 04.00 pm | 06.55 pm | 9.40 pm

United Artists Commerce-14

3330 Springvale Drive

Adjacent to Home Depot N of the intersection of 14 Mile & Haggerty

Barga n Mat nee Da y for al Shows

Start ng before 6 pm

Same Day Advance Tickets Available

WWW.UAT.COM

Uptown Birmingham 8

2 South O d Woodward Ave

Downtown B m ng ham

248-644-FILM

www.birmingham8.com

DECEMBER 2 & 3 2005

FIRST DESCENT (PG-13)

1.15 3.45 6.30 9.00 Th Fr 12.00

RENT (PG-13)

00 2.30 4.00 7.00 8.30 0.00 Th F 12:00

THE ICE HARVEST (R)

12.00 (Th Fr only) 2.15 4.45 7.15 9.45 Th Fr 2.00

DERAILED (R)

1.45 4.30 7.45 Th Fr 00 Mon hu 10.00

BE SEASON (PG-13)

2.00 9.00

KISS KISS BANG BANG (R) 115 MIN

1.30 4.15 6.45 9.5 Th Fr 2.00

SHOPGIRL (R) 118 MIN

7.30 Th F 10.15 Mon Tur 0.00

USPIZIN (PG)

Th Fr 12.30 (Mon-Thu 00) 3.30 6.00 8.15 Th Fr 10.45

With The PEA Uptown Palad um hosts the exclu e dinner

and a mov e package at the Premiere Entertainment

Auditorium. You can experience the bes movie-going

experience ton gh. Find out how!

Paladium 12 Theatre

250 North Old Woodward Ave

Downtown B m ng ham

248-644-FILM

www.paladium12.com

AEON FLUX (PG 13)

2.30 (1.00 Mon Tue) 1.45 3.00 4.5 5.30

7.00 8.00 9.30 Fr Sat 10.30 12.00

ALSO SHOWING IN OUR PREMIER ENTERTAINMENT AUDITORIUM AT 8 00PM Fri Sat

Baby's Night Out 7.00 PM

YOURS MINE & OURS (PG)

2.15 (F Sun) 2.45 5.5 7.45 Fr Sa 10.15 Sun Mon 0.00

IN THE MIX (PG 13)

30 3.45 6.5 8.45 F Sa 1.15

JUST FRIENDS (PG 13)

127th ums season 05|06

Handel's Messiah

Chicago Symphony Orchestra
Conductor: Robert Spano
Soprano: Bejun Mehta
Tenor: Andrew Garland
Bass: Andrew Garland

SATURDAY, DECEMBER 3, 8 PM
SUNDAY, DECEMBER 4, 2 PM

The presentation of Handel's *Messiah* has been the featured sign of the season for the Arts Community. Don't miss the original Michigan location, the popular, refurbished Hill Auditorium, with a 220-member chorus, orchestra and soloists.

Co-sponsored by the Carl and Isabella Brauer Fund

PRE-RELATED EVENT

Meet with Peter Blackstone
SATURDAY, DECEMBER 3, 7 PM
SUNDAY, DECEMBER 4, 1 PM
The Nicholson Mezzanine Lobby

Christmas Time Is Here

Dianne Reeves

Dianne Reeves with
Peter Martin (sax), Romero Lubambo (guitar)
Ronnie Robertson (bass), Herlin Riley (drums)

SATURDAY, DECEMBER 3, 8 PM
Hill Auditorium

Dianne Reeves returns to UMS following her inspired appearance in the Jazz Divas Summit during the Hill Auditorium Re-Opening Weekend to ring in the holiday season with style and pizzazz. Her 2004 recording, *Christmas Time Is Here*, was released to outstanding reviews, including the noted jazz critic Ben Ratliff, who called it "one of the best jazz Christmas CDs I've heard." *The New York Times*

9:00-10:00 PM WED 91.1 FM WDET 101.9 FM
See Michigan Observer/Event Page

PRE-RELATED EVENT

Dianne Reeves Post-Performance Meet and Greet
SATURDAY, DECEMBER 3, Hill Auditorium Lower Lobby

Jose Limon Dance Company

FRIDAY, JANUARY 12, SUNDAY, JANUARY 16

The Limon choreography continues to bring the art of dance to audiences around the world. The dance programs of mostly different genres include classical, modern, contemporary and

Co-sponsored by the Carl and Isabella Brauer Fund

BRONKHORST CHEVROLET

127th Annual Dance Project of the
Arts Community of the Arts

Chicago Symphony Orchestra

Robert Spano conductor

Marcus Roberts Trio, Marcus Roberts piano

Roland Guerin bass | Jason Marsalis drums

THURSDAY, DECEMBER 8, 8 PM • Hill Auditorium

The Chicago Symphony Orchestra returns for the first time since 1997 with the dazzling jazz pianist Marcus Roberts for an evening of music that includes two audience favorites — a unique arrangement of George Gershwin's *Rhapsody in Blue* and the Symphonic Dances from Leonard Bernstein's popular musical *West Side Story*.

PROGRAM

Vaughan Williams: Symphony No. 3 (London, 1945)
Gershwin: Rhapsody in Blue (1925)
Bernstein: Symphonic Dances from *West Side Story* (1957)

Sponsored by BTE Energy

Supported by the Catherine S. Arcure and Herbert E. Sloan Endowment Fund
Media Partner: WGTE 91.3 FM and Observer & Eccentric Newspapers

Call or click for tickets

ums 734.764.2538 www.ums.org

outs to the 714 area code, call 202.221.4229

Revisit CKLW's powerful rock years

In the days before MTV, we learned about new music from radio disc jockeys who played what they liked

The popular station was CKLW The station that could make or break an artist

Revisit those wild days at 8 p.m. Friday, Dec. 2, on Detroit Public Television (WTVS Channel 56) where CKLW alumni Joe Donovan, Jo Jo Shetty-McGregor, and Herb McCord, plus program producer Michael McNamara, will help host the documentary *Radio Revolution - The Rise and Fall of The Big 8*

In the 1960s if you were a top DJ, you were on CKLW, a station that had 50,000 watts of radio power and music played on it became big hits

It had 12 million listeners in prime time in 32 states and 4 provinces CKLW - "The Big 8" was a powerful force in the American music business

And the person in charge, the one who picked the hits was Rosalie Trombley, a woman who began her career as a switchboard operator. She had the power to make acts like Bob Seger, Elton John and David Bowie

Radio Revolution investigates all of it plus the international social, political and musical impact CKLW had during the 1960s and '70s

The documentary is a combination of personal anecdotes, memorabilia and recordings, film and photographs of CKLW in its heyday, as well as atmospheric re-enactments, vintage stock and modern day footage of both Detroit and Windsor

Interview subjects include music industry figures like Motown vice president Joe Summers and musicians like Martha Reeves, Alice Cooper, Tony Orlando, Mitch Ryder and MTV pioneer Les Garland

Windsor/Detroit area newsmakers from labor, industry and government offer their perspectives along with news reporters, like veteran Big 8 newsmen Grant Hudson and Dick Smythe

Radio Revolution traces the relationship between Windsor and Detroit using the meteoric rise and fall of CKLW as a meeting place and metaphor for that relationship

www.hometowntv.com

METAL

FROM PAGE D5

record really is a story of the last two years of my life and everything I've learned since then," he said.

Lyrical, the record flows in the same way, where I start by questioning what I've been taught, re-evaluating what's meaningful and recognizing what's meaningless.

"It's really about love, and learning how to love all over again."

The band prefers to be on the road and toured with Ozzfest before

immediately jumping into its current tour.

We all know that metalcore is really popular right now, and sure it would've been easy for us just to write a straight-up metalcore record to cash in on that popularity, he said. But I really do feel like we've made a record that even though it's got slight metalcore elements, is just a timeless, classic metal record.

Besides, he said, with everything I've learned about who we are as a band these past few years, why would I ever want to go back to the way things were?"

A Life Once Lost is the latest musical inferno of Philadelphia's extreme

counterculture.

"We've always looked up to bands that are doing things that are unique and not carbon copied that push limits," said vocalist Robert Meadows. "We want to be in that place with those bands, right up there with them. And we feel like we can do that."

A Life Once Lost is stripped-down metalcore.

"I want to be remembered for never conforming to any kind of label or fashion," vocalist Robert Meadows said.

Nothing has ever slowed us down. We are a band that saw what we wanted and did what we wanted to do. We've never conformed to anything, and we'll never

follow any rules."

The band is Meadows, guitarist Robert Carpenter, guitarist Douglas Sabolick, bass player Nick Frasca and drummer Justin Graves.

The band recorded the CD *Hunter* in 2005.

The whole idea behind *Hunter* is about going out and taking what it is that you want. It's about not settling with going to school, having a job, having a family. It's about not settling with someone else telling you you're not good enough, Meadows said.

lmini@oe.homecomm.net
(248) 901-2572

REVIEWS

FROM PAGE D6

that piano/wind instrument combo that produces a nice floaty-sound, but this is 60s psychedelia-lite with a Train sheen (I never thought I'd use a Train reference in a review and now that I have, I'll be in the supply closet building my noose).

I wonder, have critics become so lazy that anything with boy-girl harmony equals The Mamas and The Papas? Can any boy-girl singing duo now be compared to any other? Are Mates of State a strong enough band to be recommending to anyone over 17?

These questions remain unanswered and yet, we, the listening public, demand accountability!

And anyway, there is at least one Strokes (Television?) reference to be had on *Love Me Like You*. It's the best song on the album. And there are emo band and PJ Harvey references to be had on *I See You, You See Me*, which doesn't suck either. Download them both from iTunes and then go punch anyone who said they sound remotely like John, Michelle, Denny or Cass.

And that concludes this portion of pot-kettle black. Please come back next week.

Stephanie Tardy reviews random things in a random manner. E-mail her at stardy@homecomm.net

CHARLIZE THERON IS
Aeon Flux

PG-13 PARENTS STRONGLY CAUTIONED
Some Material May Be Inappropriate for Children Under 13
SEQUENCES OF VIOLENCE & SEXUAL CONTENT
For rating reasons, go to www.filmratings.com

AeonFlux.com

"THE MUST-SEE FAMILY FILM THIS HOLIDAY SEASON!"

Greg Russell WB TV D-att

dennisQUAID reneRUSSO
YOURS, MINE & OURS

PARAMOUNT PICTURES AND METRO GOLDWYN MAYER PICTURES AND NICKELODEON MOVIES AND COLUMBIA PICTURES PRESENT
A ROBERT SIMMONS PRODUCTION A RAJA GOSWELL FILM DENNIS QUAID RENE RUSSO "YOURS, MINE & OURS" RIP TORN
LINDA HUNT MUSIC BY CHRISTOPHE BECK SUPERVISOR SPRING ASPERS EXECUTIVE IRA SHUMAN RICHARD SUCKLE TRACEY TRENCH
PRODUCED BY ROBERT SIMMONS MICHAEL NATHANSON BASED ON THE 1986 MOTION PICTURE SCREENPLAY BY MELVILLE SHAVELSON AND MORT LACHMAN
AND STORY BY MADELYN DAVIS AND BOB CARROLL JR. SCREENPLAY BY RON BURGH & DAVID KIDD DIRECTED BY RAJA GOSWELL

PG PARENTAL GUIDANCE SUGGESTED
SOME MATERIAL MAY NOT BE SUITABLE FOR CHILDREN
SOME MILD CRUDE HUMOR

For rating reasons go to www.filmratings.com
YoursMineAndOursMovie.com

AMC FORUM 30 44681 Mound Rd 586 264 6669 GOODRICH CANTON 7 43555 Fols Rd 734 844 3456 PHOENIX WEST RIVER 30170 Grand River Ave 248 788 6672 STAR GRATIOT 35705 Gratiot Ave 586 79 3420 STAR SOUTHFIELD 26333 W 12 Mile Rd 248 372 2222	AMC LAUREL PARK 17310 Laurel Park Dr N 734 462 6200 EMAGINE NOVI 44425 W 12 Mile Rd 248 919 3456 SHOWCASE DEARBORN 24106 Michigan Ave 313 561 3449 STAR GREAT LAKES 4300 Baldwin Rd 248 454 0365 STAR TAYLOR 22265 Eureka Rd 3 3 297 2200	AMC LIVONIA 20 19500 Haggerty Rd 734 542 9909 MJR SOUTHGATE 20 15651 Trenton Rd 734 284 3456 SHOWCASE WESTLAND 6800 N Wayne Rd 734 729 1060 STAR JOHN R 32287 John R 248 585 2070 UA COMMERCE 303 S Springvale Dr 248 960 5801	BIRMINGHAM PALLADIUM 289 N Old Woodward 248 644 6161 MJR MARKETPLACE 20 18 Mile Rd & York River 586 264 1614 STAR FAIRLANE 21 18900 Michigan Ave 313 982 0015 STAR ROCHESTER 200 Barclay 248 853 2240
---	--	---	--

NO PASSES OR DISCOUNT COUPONS ACCEPTED
CHECK MOVIE GUIDE OR CALL THEATRES FOR SHOWTIMES
INFORMATION AND SHOWTIMES

The Ringo Starr's *Is It Time* is also at the art show

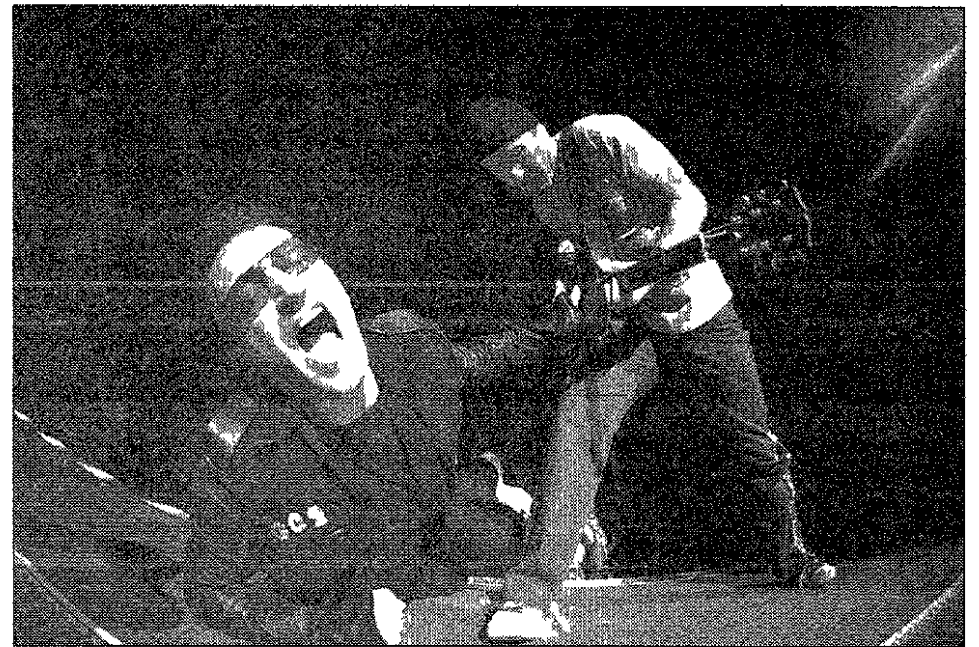
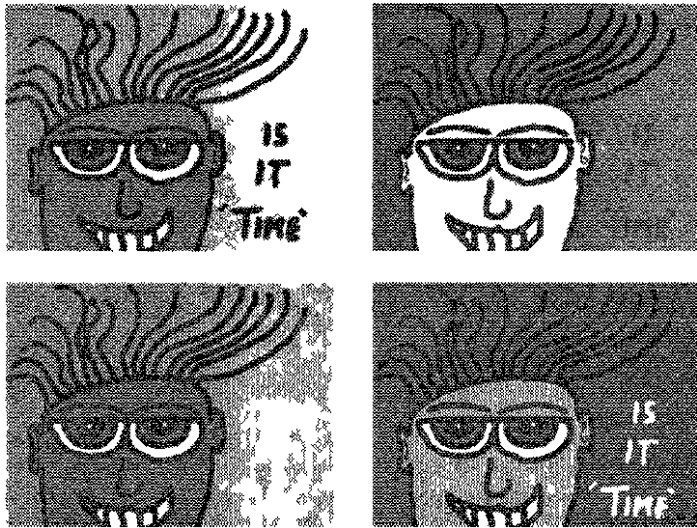

Jim Rinaldi's U2 photograph is one of the works on display

SHARE THE MAGIC OF
"THE YEAR'S BEST FILM!"
 THIS HOLIDAY SEASON

TERRY LAWSON OF *Detroit Free Press* RAVES

★★★★★! COMPELLING, REAL AND FRESH! A NEW CLASSIC VERSION OF JANE AUSTEN'S 'PRIDE & PREJUDICE!'

Girls of all ages should have much fun with this *Pride & Prejudice* and so will boys. Keira Knightley plays Elizabeth as a clever verbally athletic tomboy who has no idea how sexy she is. She climbs under your skin and into your head and in this version we understand why Darcy seems so resistant to her obvious wonderfulness. He's never seen anything like her.



Keira Knightley

PRIDE & PREJUDICE

Melanie Lynskey, Brenda Blethyn, Lisa Boddie, Jennifer Ehle, Tom Hiddleston, James McAvoy, Tom Sturges, and others



From the producers of BRIDGET JONES'S DIARY and LOVE ACTUALLY

- | | | | | |
|--|--|--|--|---|
| Goodrich Quality Theatres CANTON 8
43555 Ford Rd
734/981 1900 | Star Theatres GRATIOT
35705 Gratiot
800/FANDANGO #833 | AMC LIVONIA 20
Haggerty & 7 Mile
734/542 9909 | Imagine Entertainment NOVI
44425 W 12 Mile Rd
888/319 3456 | MJR Theatres SOUTHGATE CINEMA 20
15651 Trenton Rd
734/284-3456 |
| Regal Cinemas COMMERCE 14
3033 Spring Vale Dr
248/960 5801 | Star Theatres GREAT LAKES CROSSING
175 and Baldwin Rd
800/FANDANGO #832 | Landmark Theatres MAPLE ART
4135 W Maple Rd
248/263 2111 | Star Theatres ROCHESTER
200 Barclay Circle
800/FANDANGO #838 | MJR Theatres WATERFORD CINEMA 16
7501 Highland Rd
248/686 7900 |
| AMC FORUM 30
Corner of M 59 & Mound Rd
586/254 5663 | Star Theatres JOHN R THEATRE
32289 John R Rd
800/FANDANGO #837 | MJR MARKETPLACE CINEMA 20
15 Mile & Van Dyke
586/264 1514 | SPECIAL ENGAGEMENTS NO PASSES OR DISCOUNT COUPONS ACCEPTED
CHECK THEATRE DIRECTOR OR CALL FOR SOUND INFORMATION AND SHOWTIMES | |

For group sales information log on to www.prideandprejudicemovie.net/groupsales.

Classic rock art show on display in Troy

Images of legends John Lennon, Jimi Hendrix, Paul McCartney David Bowie, U2 Mick Jagger and many more are part of the 150-piece Classic Rock, a collection at Oakland Mall in Troy

Original art, lithographs, photographs, handwritten lyrics and animation cells sponsored by 94.7 WCSX FM feature the works of many Detroit based artists and

photographers. Some artists will be present to sign pieces. Those artists are Carl Lundgren, 1-2 p.m., Saturday, Dec. 3, Tom Weschler, 7-8 p.m. Wednesday, Dec. 7, Leni Sinclair, 1-2 p.m., Saturday, Dec. 10.

On-line pieces are auctioned weekly through Christmas to benefit Gilda's Club of Metro Detroit. The pieces can be viewed at www.wcsx.com

SPEND THIS HOLIDAY SEASON ON WITH THE DIRECTOR OF 'GROUNDHOG DAY' AND 'CADDYSHACK'

"WICKEDLY HILARIOUS!"

—DEAN RICHARDS, WB-TV

"AN AMUSING RESpite"

from the forced cheeriness of the season!
 in the tradition of 'Bad Santa!'"

—TERRY LAWSON, THE DETROIT FREE PRESS

DAVE KEHR RAVES:
"AWESOME!"

I can't think we'll be seeing a better movie this season! Harold Ramis demonstrates again how closely related comedy and suspense timing are, intricating his twists and reversals with the same dual sense of surprise and inevitability that sets up a great punch line.

www.theiceharvest.com

JOHN CUSACK BILLY BOB THORNTON CONNIE NIELSEN

THE ICE HARVEST

WRITTEN BY RICHARD BUSSE & ROBERT BENTON DIRECTED BY HAROLD RAMIS

- | | | | | | |
|---|--|---|---|--|---|
| Phoenix Theatres BEL AIR CENTRE
8 Mile Rd E of Van Dyke
313/438 3464 | Regal Cinemas COMMERCE 14
3033 Spring Vale Dr
248/960 5801 | Regal Cinemas FRENCHTOWN SQUARE MALL 8
212 N Monroe
800 326 3264 | Star Theatres JOHN R THEATRE
32289 John R Rd
800/FANDANGO #837 | MJR MARKETPLACE CINEMA 20
15 Mile & Van Dyke
586/264 1514 | Star Theatres SOUTHFIELD
12 Mile & Telegraph
800/FANDANGO #839 |
| Uptown Entertainment BIRMINGHAM 8
211 S Old Woodward Av
248 644 FILM | Star Theatres FAIRLANE
18900 Michigan Ave
800 FANDANGO #834 | Star Theatres GRATIOT
35705 Gratiot
800/FANDANGO #833 | AMC LAUREL PARK 10
17310 Laurel Park Dr
734/462 8200 | Imagine Entertainment NOVI
44425 W 12 Mile Rd
888/319-3456 | MJR Theatres SOUTHGATE CINEMA 20
15651 Trenton Rd
734/284-3456 |
| Imagine Entertainment CANTON
39535 Ford Rd
888 3 9 3456 | AMC FORUM 30
Corner of M 59 & Mound Rd
586/254 5663 | Star Theatres GREAT LAKES CROSSING
75 and Baldwin Rd
800 FANDANGO #832 | AMC LIVONIA 20
Haggerty & 7 Mile
734/542 9909 | National Amusements SHOWCASE DEARBORN
24105 Michigan Ave
313/561 3449 | Star Theatres TAYLOR
22285 Eureka Rd
800/FANDANGO #840 |

A CHRISTMAS CAROL

BOOK BY GUY DEBLAGHAK MUSIC BY KEVIN ROYTY
LYRICS BY SHIPPY DEBLACHAK AND KEVIN ROYTY



THE BRASS OF DETROIT CHAMBER WINDS & STRINGS

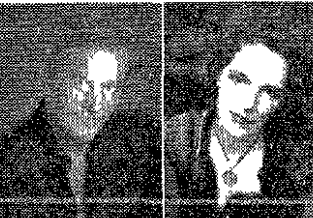

PAT BOONE BONNIE RIDEOUT

Troupe America Inc and Mainstage Artists Management Present
Charles Dickens' A Christmas Carol
It will delight you never ceasing to touch hearts prompt a little self examination and jump start the Christmas spirit —*The Seattle Times*
Sat Dec 3 2 & 8pm

Broadway's Spirit of Christmas
A lavish holiday spectacular production for the whole family
Sun Dec 4 3 & 7pm

Sponsored by **Macomb Daily**

BANK ONE MOSTLY MICHIGAN SERIES

The Brass of Detroit Chamber Winds & Strings with The Sounds of Christmas

Holiday Brass concerts are a beloved tradition and for good reason. Here a holiday faves played with high gloss polish and an exuberant sense of occasion —*Detroit Free Press*
Tues Dec 6 7 30pm

Sponsored by **WDET 101.5FM**

This activity is funded in part by Michigan Council for Arts and Cultural Affairs and Michigan Humanities Council

Christmas with Pat Boone

The audience came away feeling they were amongst friends of Pat Boone —*Joe LaGua of a New York State Fair*
Fri Dec 9 2 & 8pm

Sponsored by **AMSCO**

A Scottish Christmas® Featuring Bonnie Rideout

A Scottish Christmas ancient and infectious and so compelling no matter what the site or ancestry —*CBS Sunday Morning*
Sun Dec 11 3pm

Ticket Prices \$10-\$45

FOR MORE INFORMATION

Star Tickets PLUS Ticket Office at Macomb Center

586 286 2222 • www.MacombCenter.com

Star Tickets® 800 585 3737

Tickets are available at all Michigan Meijer Stores

Artists and programs are subject to change without notice
NO REFUNDS / LIMITED EXCHANGES

MACOMB CENTER
FOR THE PERFORMING ARTS

A Community Enrichment Program of Macomb College

Fill Your with Christmas!

Now Playing!
2005 Edition
RADIO CITY CHRISTMAS SPECTACULAR
THE ROCKETTES

PRESENTED BY
Fifth Third Bank

NOW - DEC. 24
FOX THEATRE

GREAT SEATS STILL AVAILABLE!
At the Fox Theatre and Joe Louis Arena box offices, Hockeytown Authentics in Troy and all ticketmaster outlets including Marshall Field's

Charge by Phone (248) 433-1515
SAVE! Groups of 10 or more (313) 771-3099
For information, call (313) 471-6611

Fifth Third Bank FRIDAYS! • *Save \$10.00 per ticket
Friday 7:30 performances only Offer not valid at outlets Ask for ticket type MFIFTH
*Based on availability Not valid on Elite or Gold Circle seating
No double discounts

21st Annual

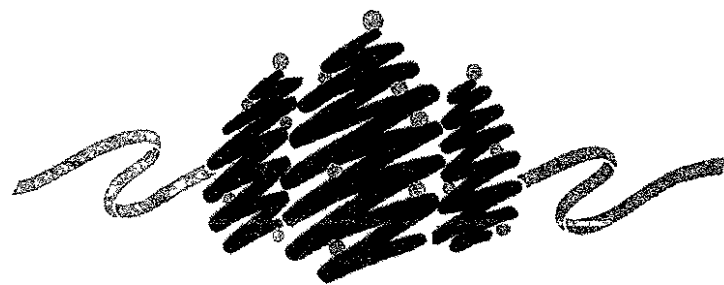

FESTIVAL OF TREES

A Benefit for Children's Hospital of Michigan

... Through the Eyes of a Child

November 25 - December 4, 2005

Rock Financial Showplace

46100 Grand River Avenue, Novi, Michigan

The 21st Annual Festival of Trees is THE place for families to kick off the holiday season. This year's event will be five times larger than last year with more activities for everyone in the family to enjoy.

Festival of Trees is a public display of hundreds of professionally designed holiday trees, wreaths, a gingerbread village, a festive gift shop, entertainment, children's activities, rides, and a Secret Santa Shop just for kids.

GENERAL ADMISSION

Adults: \$10, Seniors: \$8, Children (2-12): \$8, Children under 2 are free.

DATES AND TIMES

Friday, November 25
Noon - 9:00 pm

Saturday, November 26
10:00 am - 3:00 pm

Sunday, November 27
through

Saturday, December 3
10:00 am - 9:00 pm

Sunday, December 4
10:00 am - 6:00 pm



Lunch With Santa

Sunday, November 27
and Sunday, December 4

11:00 am - 1:30 pm

Adult \$25, Child (2-12) \$20,

Children under 2 FREE

Advance reservations only.

Win 4 tickets to Lunch With Santa on December 4th!

Just send a note answering,

"Why do you want to have lunch with Santa?"

Please e-mail your answer to cyoung@oe.homecomm.net or mail to The Observer & Eccentric, Attn: Lunch With Santa, 36251 Schoolcraft Road, Livonia, MI 48150.

Four winners will be selected.



For further information, call (313) 966-TREE or visit our Web site at www.fot.org

All proceeds benefit pediatric research at Children's Hospital of Michigan.

Send fax or e mail items for consideration in Get Out! at least two weeks in advance to Lana Mini Observer & Eccentric Newspapers 805 E Maple Birmingham MI 48009 fax (248) 644 1314 or e mail lmini@oe homecomm net

ART EXHIBITS

Detroit Institute of Arts

Camille Claudel and Rodin Fateful Encounter through Feb 5 2006 5200 Woodward Ave Detroit timed tickets include general museum admission and exhibit audio tour \$8 \$14 (877) 342 8494 or visit www.dia.org

University of Michigan Museum of Art

Betye Saar Extending the Frozen Moment an exhibition of more than 60 works by artist Betye Saar through Jan 8 525 South State University of Michigan campus Ann Arbor suggested donation is \$5 call (734) 763 UMMA or visit www.umma.umich.edu

Screenprints

The Art of Screenprint at the Detroit Institute of Arts 5200 Woodward Detroit \$3 \$6 (313) 833 7900 or visit www.dia.org

ART GALLERIES

Susan Hilberry Gallery

Paintings by Holly Coulis David Deutsch Ryan McLaughlin and Ellen Phelan through Jan 14 at 700 Livernois Ferndale (248) 541 4700

Elaine Jacob Gallery

Susan Unterberg A Retrospective exhibit runs through Dec 16 located at 480 W Hancock in Detroit at Wayne State University (313) 993 7813 www.art.wayne.edu

Ann Arbor Art Center

Out of the Gates a photography exhibit documenting the installation of Christo's famous gates project in Central Park through Dec 23 117 West Liberty Ann Arbor call (734) 994 8004 or visit www.annarborartcenter.org

Oakland Community College

Student Art Show Paintings ceramic works and arts and crafts items by students of the Highland Lakes Campus At the campus at Woodland Hall Library 7300 Cooley Lake Road Waterford 8 a m to 10 p m Monday Friday 8 a m to 4 30 p m Friday 9 a m to 3 p m Saturday

Sherry Washington Gallery

The Grids of Life works by New York artist David Fludd continues through Dec 3 1274 Library Street Detroit (313) 961 4500 or www.sherrywashingtongallery.com

Photo exhibit

Group Photo an exhibit of works by five photographers through Dec 30 Opening reception 6 8 p m Dec 2 Paint Creek Center for the Arts 407 Pine St Rochester call (248) 651 4110 or visit www.pccart.org

Lemberg Gallery

James Stephens Ecotone New Paintings through Dec 3 23241 Woodward Ferndale (248) 591 6623 or www.lemberggallery.com

ART ETC.

Ann Arbor Art Center's Gallery Shop

Holiday gifts sold through Dec 31 featuring ceramics glass fiber hand made wood furniture and musical instruments. Art Center members receive 20 percent discount For information call (734) 994 8004 Ext 118 Located at 117 West Liberty in downtown Ann Arbor

Birmingham Bloomfield Art Center

Special shopping event open Dec 2 17 Event features 150 artists from eight states with fibers glass ceramics wood photography and more (248) 644 0866 or visit BBAC 1516



S Cranbrook Road Birmingham for information visit www.bbartcenter.org

Historic Hecker-Smiley Mansion

Kinder Show presented by Juris Galleries featuring arts and crafts by local artists with sales to benefit The Detroit Institute for Children private preview 5 30 7 30 p m Friday Dec 2 public reception 7 30 9 30 p m Gallery hours 10 a m 9 p m Saturday Dec 3 and 10 a m 4 p m Sunday Dec 4 5510 Woodward Detroit

Community Work Opportunities

Third annual Gala Event 10 a m 3 p m Dec 2 Gallery items displayed are for purchase at 5900 Lilley Road Suite 108 in Canton Items for sale are created by Community Work Opportunities customers a non profit agency serving developmentally disabled citizens Call (734) 981 3709 for information

BALLET

The Jeffrey Ballet's The Nutcracker

Performances at 7 30 p m Thursday Saturday Dec 1 3 2 p m Saturday and 1 and 6 p m Sunday Dec 4 at Detroit Opera House 1526 Broadway Detroit opera programs \$28 \$68 dance programs \$25 90 call (313) 237 SING or TicketMaster at (248) 645 6666 or visit www.MichiganOpera.org

More Nutcracker performances

The Plymouth Canton Ballet Company performs *The Nutcracker* with the Plymouth Symphony Orchestra 11 a m and 4 30 p m Dec 3 and 2 p m Dec 4 Salem High School Auditorium Plymouth (734) 451 2112

Lake Orion High School

The Michigan Ballet Theatre performs *The Nutcracker 2* and 7 p m Saturday Dec 10 and 1 and 6 p m Sunday Dec 11 Lake Orion High School (248) 652 3117

The Michigan Classic Ballet Company

Performs *The Nutcracker* 11 a m and 3 30 p m Dec 10 and 3 p m Dec 11 Mercy High School Farmington Hills (248) 334 6964

More Nutcracker

Rose Marie Floyd Contemporary Civic Ballet Company of Royal Oak 2 p m and 7 p m Dec 17 Clawson High School Clawson (248) 641 9063

Avondale performance

The Nutcracker performed by Michigan Ballet Theatre 2 p m and 7 p m Dec 21 22 Avondale Performing Arts Center Avondale High School Auburn Hills (248) 652 3117

CLUBS

220 Merrill Street & Edison Lounge

220 E Merrill Birmingham (248) 645 2150 Extensive drink menu live music dancing Eclectic and American Nouveau cuisine

Belmont Bar

10215 Joseph Campau Hamtramck (313) 871 1966 Mademoiselle Mondays \$10 for martini and manicure Therapeutic massage \$1 minute Punk nights Tuesdays Live rock Wednesdays DJs and local bands on week ends Call as schedule changes

Blind Pig

Long time hip music spot 208 S First St Ann Arbor (734) 996 8555 www.blindpigmusic.com

Blue Martini

Live music 8 11 p m Tuesdays through Thursdays and Saturdays and Sundays 201 Hamilton between Woodward and Old Woodward one block north of Maple (248) 258 3005

Bosco

Enjoy noWax nights at 7 p m every Wednesday at the Bosco 22930 Woodward Ave Ferndale Download music into your MP3 Player take a number and wait your turn to be DJ and spin three songs No cover For more information visit www.thebosco.com or call (248) 541 8818 21 and over only

Club Bart

22726 Woodward Ferndale (248) 548 8746 21 & over only

Club 2000

Fat Twosdays with DJ Carl the Invisible Man 9 p m Tuesdays Hip hop 18 & over 299 E Woodbridge Detroit (313) 235 2233

Crazy Moe's Cafe

2 N Saginaw St Pontiac (248) 322 5550 Food dancing music

Danny's Irish Pub

Laid back small friendly 2824 Woodward Ave Ferndale (248) 546 8331

Dino's Lounge

Live bands on weekends football specials on Sundays Hip laid back friendly Woodward Avenue just south of Nine Mile Road in Ferndale (248) 591 DINO

Elysium

Lounge dance and happy hour 3 9 p m

Tuesdays Fridays Nightclub hours Fridays and Saturdays 9 p m to 2 a m (313) 962 2244 625 Shelby Detroit www.elysiumlounge.com

Emerald Theatre

Concert House dancing 32 North Walnut Mount Clemens (586) 913 1920

Jam at The Gem

The series returns to the Gem Theatre patio Every Thursday 5 8 p m Guests can enjoy summer drink specials appetizers and entrees from the Century Grille For more information call (313) 963 980 or visit online at www.gemtheatre.com

John Cowley & Sons Irish Tavern

33338 Grand River Ave Farmington (248) 474 5941 Food drinks and friendly pub atmosphere

Leland City Club

Avant garde Located in the Ramada Hotel building 400 Bagley Street in downtown Detroit Open til 4 a m Access through unmarked door on the First Street side of the Ramada www.lelandcityclub.com

Rainbow Room

6640 E Eight Mile Road Detroit Gay friendly Laid back atmosphere Dancing (313) 891 1020

X/S

High energy dance club 1500 Woodward northeast corner at John R Detroit

Sky Club

Tango salsa and Latin dancing every Wednesday beginning at 8 p m Located above Sangria's Restaurant 401 S Lafayette Royal Oak (248) 543 1964

COMEDY

Wise Guys

John Caponera (The Good Life) with special guests Sal Demilio and Joey Bielaska Dec 1 3 Lowell Sanders (Joe Somebody) with Connie Ettinger and Michael Orenstein Dec 8 10 shows are 8 p m Thursday and 8 and 10 30 p m Friday and Saturday (8 p m Saturday show is non smoking) at 40380 Grand River Novi Call (248) 919 3216

Second City

Mainstage show is *In iPod We Trust* running Wednesday Sunday and children's theater production *After the Beanstalk* a limited engagement on Saturday mornings through Dec 17 42705 Grand River Ave Novi (248) 348 4448

Mark Ridley's Comedy Castle

Stand up 269 East Fourth Royal Oak (248) 542 9900 www.comedycastle.com

Joey's Comedy Club

Stand up at two locations 36071 Plymouth Road Livonia (734) 261 0555 and 5070 Schaefer Dearborn (313) 584 8885 www.joeyscomey.com

FAMILY

Detroit Science Center

Exhibits include *A Journey to Our Future* is now open to accompany center's new permanent Space Laboratory exhibit 5020 John R Detroit \$6 7 call (313) 577 8400 or visit www.detroitssciencecenter.org

The Second City

Debuts its first children's theater production *After the Beanstalk* suitable for ages 5 10 performances run every Saturday at 11 a m through Dec 17 \$10 (248) 348 4448 new Second City Theatre 42705 Grand River Ave Novi

HOLIDAY EVENTS

Spotlight Players

It's a Wonderful Life performed Dec 2 4 9 11

and 16 17 at Cherry Hill Village Theater 50400 Cherry Hill Road Canton tickets \$18 show times 8 p m Fridays and Saturdays 2 p m on Sundays call (734) 394 5460

Washtenaw Community College

Peter Sparling Dance Company and Dance Gallery Studio's Youth Ensemble dance new ballet and modern pieces at Winter Wonderland performance 7 p m Dec 2 at Towsley Auditorium 4800 East Huron River Drive Ann Arbor Tickets \$10 at Dance Gallery Studio 815 Wildt Street in Ann Arbor (734) 747 8885

General Motors Employees' Choir

Sacred and secular music to celebrate the season at the following locations 7 30 p m Dec 2 Good Shepherd Lutheran Church 1950 Baldwin Lake Orion Dec 5 First Baptist Church 309 N Main Royal Oak Dec 9 Pilgrim Congregational Church 3061 N Adams Bloomfield Hills

Oakland Community College

Oakland Community College's Just for You arts and entertainment series presents Michigan Opera Theatre performing a selection of Broadway classics and holiday music at 7 30 p m Friday Dec 2 at OCC's Smith Theatre at the Orchard Ridge campus 27055 Orchard Lake Road tickets and information (248) 341 2270

Royal Oak Symphony Orchestra

December Concert at 8 p m Friday Dec 2 at the Royal Oak Kimball High School Auditorium which is located at Crooks Road just south of Normandy The program includes Music for the Royal Fireworks by George F Handel Suite 1 from the Nutcracker Ballet by Peter I Tchaikovsky other selections and a Carol Songfest for audience and orchestra Admission is \$10 for adults \$7 for senior citizens and students and free admission for those under age 18 Tickets may be purchased at the door For further information call (248) 988 6991 or visit or website at www.royaloakorchestra.org

Noel Night

Over 70 acts including The Festival Singers the Michigan State University Jazz Band the Detroit Dance Collective the Mosaic Singers and the Kidz Klez Band of Michigan perform at 33rd annual Noel Night 5 9 30 p m Saturday Dec 3 at Midtown Detroit's Cultural Center institutions all open free of charge that evening located between Kirby and Forest and Cass Avenue and John R Free shuttle between venues For information call (313) 577 5088 or visit www.detroitmidtown.com for further information

Waterford Cultural Council

Motor City Brass Band performs at annual Holiday Brass concert 7 p m Saturday Dec 3 at Central United Methodist Church 3882 Highland Road Waterford \$15 (248) 618 7529

Birmingham Concert Band

Annual extravaganza Holiday Ornaments with Lutheran High Northwest Concert Choir 3 30 p m Sunday Dec 4 at the Lutheran Church of the Redeemer 1800 W Maple (at Chesterfield) Birmingham

Celebration Youth Orchestra

Concert 7 p m Thursday Dec 6 at Village Theater at Cherry Hill 50400 Cherry Hill in Canton tickets \$6 call Plymouth Symphony for information at (734) 451 2112 or visit www.plymouthsymphony.org

Detroit Concert Choir

Music for Christmas concert 7 30 p m Saturday Dec 10 St Hugo of the Hills 2215 Opdyke Bloomfield Hills 3 p m Sunday Dec 11 Old St Mary's in Greektown 646 Monroe and 4 p m Sunday Dec 18 St Martin de Porres 31555 Hoover (north of 13 Mile) Warren tickets \$20 and \$18 for seniors and students \$10 for young adults (through 21 years old) (313) 882 0118

Kirk in the Hills

Kirk in the Hills Chancel Choir and the Detroit Chamber Winds and Strings present part I of Handel's *Messiah* and *Magnificat* a cantata by Johann Sebastian Bach at 7:30 p.m. Dec. 4 in the Sanctuary of Kirk in the Hills 1340 W. Long Lake Road Bloomfield Hills tickets \$18 general admission \$15 seniors \$12 students call (248) 626 2515 ext 109

Detroit World Outreach

Christmas with the Family 2005 features music drama skits dance numbers and desserts at the end of every performance 7 p.m. Dec. 8 9 and 10 tickets \$5 before Dec. 3 and \$10 after that date available at church 23800 West Chicago Redford (313) 255 2222 Ext 236

Troy High School Orchestra and Choir

Ring in the holiday season at Troy High School 7 p.m. Thursday Dec. 8 Free concert features music from the Mamma Mia Rumanian folk dances and seasonally appropriate selections The Freshman concert and symphony orchestras Country Fiddlers concert choir and Stardust Vocal Ensemble perform For more information call (248) 823 2700 or visit www.troyhighorchestra.org

Kwanzaa

The Storytellers (Robert and Audrey Allison) appear 2-4 p.m. Sunday Dec. 10 at Art Van Furniture 22555 Greenfield in Southfield The duo will visit with guests to share stories about African American heritage and the celebration of Kwanzaa and demonstrate ethnic musical instruments The Storytellers encourage children participation For information call (248) 569 3770

Sleigh rides

John McGuire of the Guernsey Farms Dairy donated a one horse open sleigh to the Northville Community Foundation for use at Maybury Farm to kick off Hayrides and Sleigh Rides at the Maybury Farm on Eight Mile Road just west of Beck Road in Northville The farm's winter hours are noon until 5 p.m. Wednesday thru Sunday hayrides and sleigh rides (weather depending) will be scheduled at 1 p.m., 2 p.m. 3 p.m. and 4 p.m. Friday Saturday and Sundays. For group rates call (248) 374 0200

JAZZ

Windsor Detroit Jazz Club

Ongoing gigs in Oakland County Presenting Chuck Moss and the Paint Creek Jazz Society Band 1-4 p.m. first and third Saturday of every month Shield's Pizza 25101 Telegraph (northwest corner of 10 Mile and Telegraph) Southfield \$8 cover Call (248) 478 0172

Jazz at Wharton Center

The MSU Professors of Jazz features Kevin Mahogany 8:30 p.m. Thursday Feb. 23 at Pasant Theatre and Ingrid Jensen Wednesday March 22 at Stoddard Grand Tier Lounge (517) 432 2000 or 1 800 WHARTON or visit www.whartoncenter.com

MORE MUSIC

Coffee Beanery Cafe

Larry Arbour 7:30 p.m. Saturday Dec. 10 located at 28557 Woodward Berkley (248) 336 9930

Magic Bag

22920 Woodward Ferndale (248) 544 3030

Open Mike

Musicians perform on open mike night every Thursday 8-11 p.m. at The Bubble Bliss 125 S Main Street Come and watch or bring an instrument to perform

KerryTown

415 North Fourth Ave. Ann Arbor reservations recommended (734) 769 2999 www.kerrytownconcerthouse.com

Live @ 744

At the Joanne Winkelman Hulce Center for

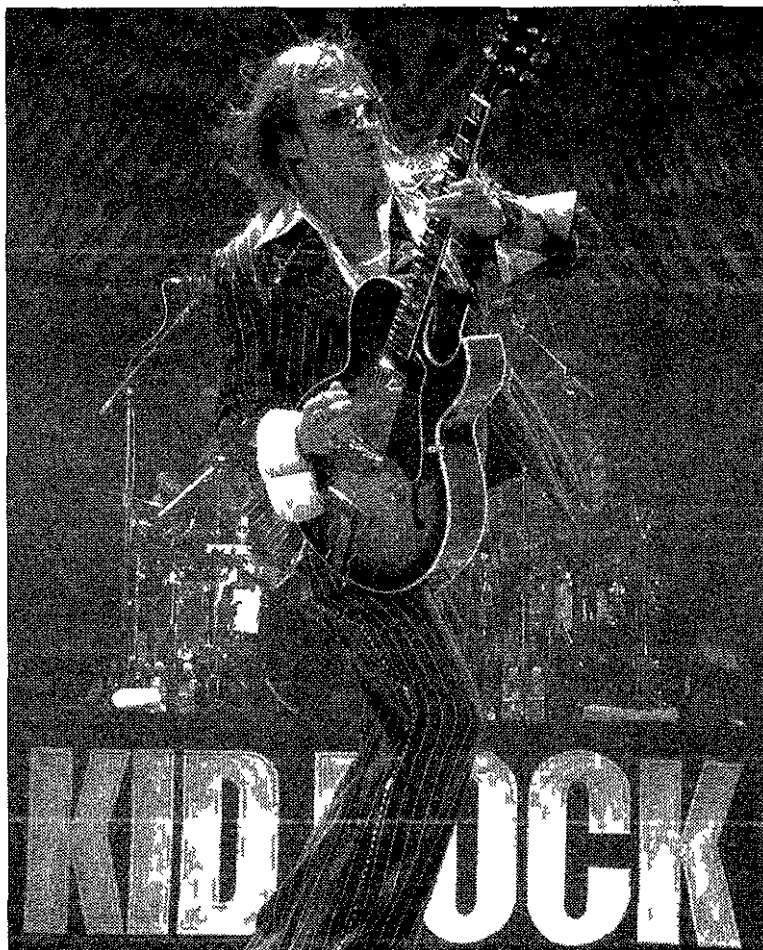

MUSIC

When something big happens in Detroit, Kid Rock is usually a part of it. The Super Bowl is no exception. Kid Rock will play the Joe Louis Arena at 8 p.m. Feb. 3. Tickets go on sale this Saturday, Dec. 3, at all Ticketmaster locations. Tickets are \$39. Charge by phone call (248) 654-6666 or visit www.cellardoor.com or www.olympiaentertainment.com

the Arts on Friday evenings throughout the fall with Back Forty funk and grass roots performs at 7 p.m. 74 N Sheldon Road Plymouth (734) 416 4278

Station 885

885 Starkweather Plymouth Tony Ruda and Pat Smith play jazz every Thursday 7-10 p.m. (bass and piano)

Trinity House Theatre

Dick Siegel in concert at 8 p.m. on Saturday Dec. 10. Tickets are \$12. Call (734) 464 6302. For more information www.trinityhouse.org

At home, On-line

www.RadioIndiePop.com features a different indie band each month. This month it's Animal Collective. Listening to the music is free and there's no advertising.

MUSEUMS

Henry Ford Museum

Current exhibits include *Behind the Scenes 50 Years of Disneyland* 9:30 a.m. to 5 p.m. daily \$10-14 20900 Oakwood Boulevard west of the Southfield Freeway and south of Michigan Avenue Dearborn. Additional charges and varying hours for entry to Greenfield Village Ford Rouge Factory Tour and IMAX Theatre. For more information call (313) 982 6001 or visit www.hfmgv.org

Cranbrook Science Museum

Featured exhibit is *It's a Nano World*. Permanent exhibits include planetarium nature center and Bat Zone Conservatory 39221 Woodward Bloomfield Hills general admission is \$5-7 planetarium \$1-3 (248) 645 3200 or www.cranbrook.edu

Charles H. Wright Museum of African-

American History

Gridiron to Greatness African Americans in Professional Football through March 26 2006 315 East Warren Avenue Detroit \$5-\$8 members and children under 3 free (313) 494 5800 or www.maah.detroit.org

Detroit Science Center

Premiere of *Magnificent Desolation Walking on the Moon* narrated by Tom Hanks and new planetarium show *Journey to the Edge of Space and Time* \$6 shows run indefinitely. Museum hours are 9 a.m. to 3 p.m. Tuesday Friday 10:30 a.m. 6 p.m. Saturday and noon to 6 p.m. Sunday 5020 John R Detroit \$6-\$7 (313) 577 8400 or www.detroitsciencecenter.org

Detroit Historical Museum

Reflections The Mary Wilson Supreme Legacy Collection an exhibit of Supremes costumes through Feb. 12 5401 Woodward Detroit admission is \$3-\$5 (313) 833 1805 or www.detroithistorical.org

SOMETHING DIFFERENT

Dinosaur Discovery Day

The University of Michigan Exhibit Museum of Natural History features Dinosaur Discovery Day 9 a.m. 5 p.m. Saturday Dec. 3. Take part in fossil dig perform a dino puppet show take home dino craft. Free 30 minute dinosaur tours at 2 p.m. Saturdays and Sundays (no tour on Dec. 3) 1109 Geddes Ann Arbor (734) 764 0478 or visit isa.umich.edu/exhibitmuseum

Winter Astrology Psychic Fair

Features astrologers palmists card readers and psychics 10 a.m. 5 p.m. Saturday Dec. 3 Clawson Troy Elks 1451 E. Big Beaver (between Rochester and John R) in Troy \$5 admission

\$20 readings (248) 528 2610

Noel Night

Midtown Detroit's Cultural Center wide holiday Open House Celebrate Detroit's diverse holiday traditions at the museums galleries churches and more all from 5-9:30 p.m. on Saturday Dec. 3. Horse drawn carriage rides carolers music dance children's activities arts & crafts shopping and yule tide treats. Location primarily Kirby and Forest on the north and south and John R and Cass on the east and west.

Breakfast with Santa

Presented by the Community House and Birmingham Youth Assistance Saturday Dec. 3 at the Community House 380 South Bates in Birmingham Groves High School Brass Ensemble performs holiday music. Each child can visit with Santa and can receive a gift. Two breakfast seatings available at 9 a.m. and 11:30 a.m. Tickets \$12. Call (248) 642 4882 to reserve seats.

Largest Greek Salad

The Bice family and supporters of Children's Hospital of Michigan will be creating Detroit's Largest Greek Salad noon-3 p.m. Sunday Dec. 4 at Temple Beth El located at the northwest corner of 14 Mile and Telegraph in Bloomfield Hills. Salads \$5. Proceeds help purchase Beanie Babies for Children's Hospital. Prepaid tickets available at any Leo's Coney Island Temple Beth El or by calling (248) 851 4203. Tickets also available at door on Dec. 4.

The Bells of St. Mary's

Silver Screen Classics is a monthly series offered at National Amusements Cinemas. Enjoy a classic film popcorn and a soft drink for only \$1 at Showcase Cinemas Westland 6800 N. Wayne Road at 1 p.m. Wednesday Dec. 7 (734) 729 1060.

Automotive and ad art

Automotive Exhibit Drawing Power Motor City Ad Art in the Age of Muscle and Chrome through March 2006 Detroit Public Library Skillman Branch Library 121 Gratiot Avenue free (313) 628 2750

Oakland Town Hall

Dr. Elliott Engel continues the Oakland Town Hall lecture series with Bob Farmer April 12 and Erma Stewart May 10. Lectures are at 10:30 a.m. at St. George Cultural Center 43816 Woodward Bloomfield Hills Luncheon is \$58 and lectures \$57. For information call (248) 625 3117.

Benefit Hurricane Katrina

Eminem and 50 Cent items are available on eBay to benefit victims of Hurricane Katrina. Visit eBay.com Collectibles for A Cause.

THEATER - COLLEGE

Tennessee Williams

The Hilberry Theatre presents *Sweet Bird of Youth* runs through Jan. 28 \$15-28 4743 Cass at Hancock (313) 577 2972 or www.hilberry.com

THEATER - COMMUNITY

Players Guild of Dearborn

Man of La Mancha 8 p.m. Friday and Saturday Dec. 2-3 and 2:30 p.m. Sunday Dec. 4 \$16 with reservations recommended call (313) 561 TKTs or visit www.playersguildofdearborn.org 21730 Madison Dearborn

Farmington

The Farmington Players Community Theater presents *Comic Potential* a futuristic comedy about a screenwriter who gets more than he bargains for when he falls in love with his robotic leading lady. Shows are at 8 p.m. Dec. 1-2-3-8-9-10 and matinee at 2 p.m. Dec. 4 tickets \$13. Call (248) 553 2955 or visit www.farmingtonplayers.org for more information.

tion Located at 32332 W 12 Mile Rd Farmington Hills.

THEATER - PROFESSIONAL

Abrecht Performance Space

Action by Sam Shepard through Dec. 3 shows at Friday and Saturday at 8 p.m. 442 E Lafayette in Greektown Detroit for more details visit www.theabrecht.com or e-mail reservations@theabrecht.com

Music Hall Center for the Performing Arts

Children's Letters to God Midwest premiere of off Broadway musical hit 3 p.m. Saturday Dec. 3 at Music Hall Center for the Performing Arts \$39 adults \$29 for children 14 and under (248) 645 6666 or visit www.ticketmaster.com

Planet Ant Theatre

N. Maureen Hayden's *The Weekend* runs through Dec. 3 shows at 8 p.m. Thursday Saturday and 2 p.m. Sunday 2357 Caniff Avenue Hamtramck \$5-15 (313) 365 4948 or www.planetant.com

Purple Rose Theatre

Tennessee Williams *The Glass Menagerie* through Dec. 18 137 Park Chelsea \$25-\$35 call (734) 433 7673 or visit www.purplerosetheatre.org

City Theatre

Altar Boyz award winning musical comedy through Dec. 18 8 p.m. Tuesday Saturday 2 p.m. Saturday and Sunday 7:30 p.m. Sunday 1 p.m. Thursday 2301 Woodward Detroit \$22-\$50 \$45 (248) 645 6666 or visit www.ticketmaster.com

Menopause the Musical

Celebrate the longest running professional production in Detroit history at the Gem Theatre. Show times are 8 p.m. Tuesday Saturday and also 4 p.m. Saturday and 2 p.m. Sunday. Tickets (\$39-\$50) can be bought through the Gem Theatre box office by calling (313) 963 9800. Ticketmaster charge by phone (248) 645 6666 and online at www.ticketmaster.com

TICKETS ON SALE

Lynyrd Skynyrd

Tickets on sale at 10 a.m. Dec. 2 for Dec. 30 show at The Palace with special guests 38 Special \$37-\$50 reserved and \$10 general admission. Call (248) 645 6666 or visit Palacenet.com. Tickets also available at The Palace Box Office and all Ticketmaster outlets.

Sister's Christmas Catechism

Coming to the Century Theatre and playing through Dec. 31 tickets on sale now \$17-\$25 39 50 (313) 963 9800

Dave Matthews Band

\$52 at Fox Theatre and Joe Louis Arena box offices Hockeystown Authentics in Troy and all Ticketmaster locations including Marshall Field's. Concert is Saturday Dec. 3 at Joe Louis Arena. To charge by phone (248) 645 6666. To buy online OlympiaEntertainment.com or Ticketmaster.com. For info call (313) 471 6611

Rock & Roll Christmas Spectacular

WOMC's Rock & Roll Christmas Spectacular III features The Miracles The Vogues The Shangri-Las The Reflections Frankie Ford Bette Midler Tribute from the Las Vegas Show and Charlie Thomas 8 p.m. Friday Dec. 30 at the Ford Community Performing Arts Center 15801 Michigan Ave. Dearborn tickets \$25-\$55 free hors d'oeuvres and cash bar call (313) 943 2354 for information

University Musical Society

127th season Michigan League Ticket Office 911 North University Ave. Ann Arbor (800) 221 1229 all venues in Ann Arbor

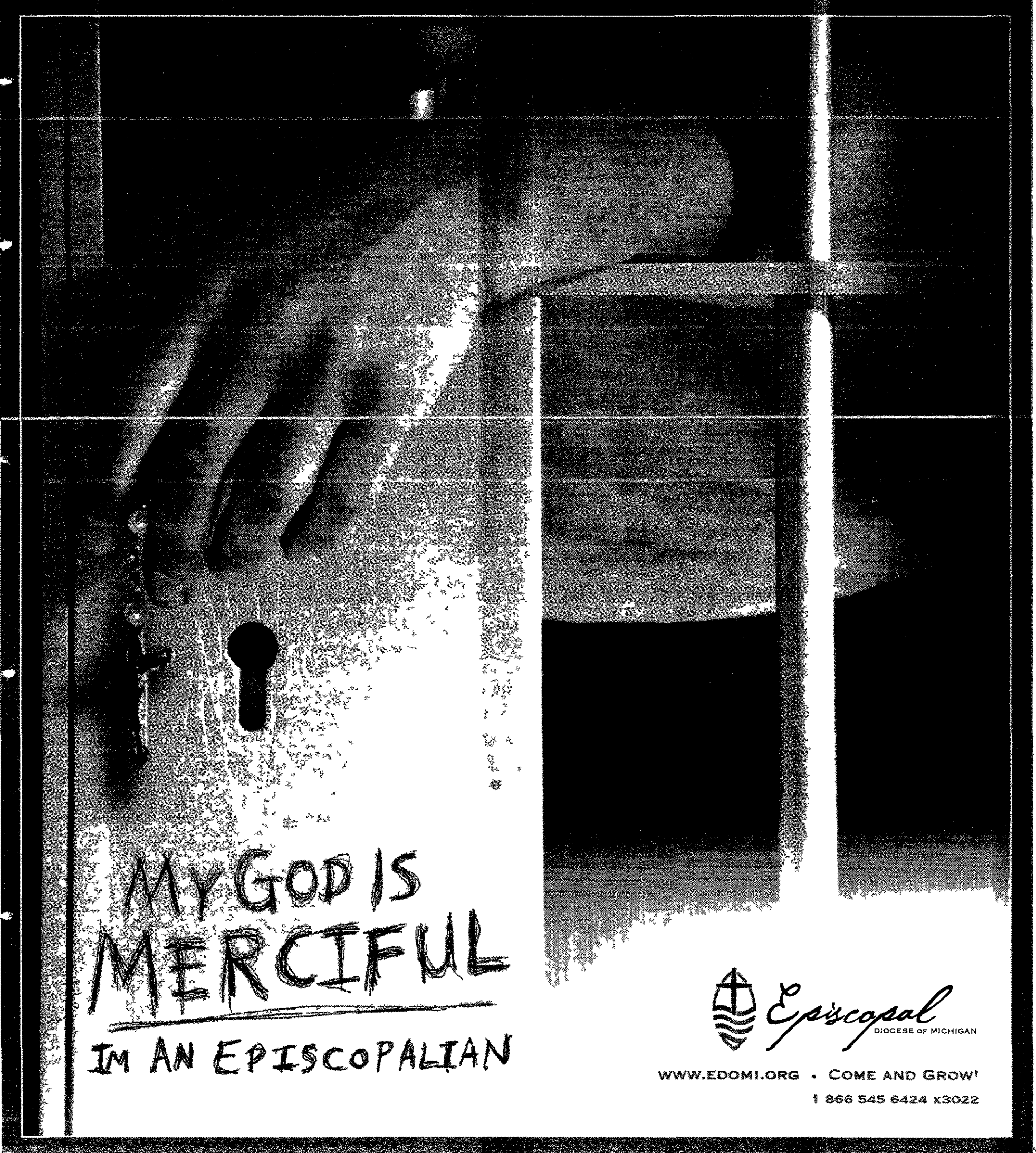

MY GOD IS
MERCIFUL

IN AN EPISCOPALIAN



Episcopal
DIOCESE OF MICHIGAN

WWW.EDOMI.ORG • COME AND GROW!
1 866 545 6424 x3022