

Your hometown newspaper serving Plymouth and Plymouth Township for 118 years

PLYMOUTH Observer

Winners of more than 100 state and national awards since 2001



THURSDAY
March 25 2004
75 cents

VOLUME 118 NUMBER 61

www.hometownlife.com

©2004 HOMETOWN COMMUNICATIONS NETWORK

Win a \$500 Farmer Jack shopping spree
See page C8 for details

Pipeline

Road project

Wayne County officials have notified Plymouth and Plymouth Township that the paving project along Sheldon Road from Joy to Ann Arbor Trail is scheduled to start Monday, March 29. The project was originally supposed to coincide with the Sheldon Road underpass project, but that has been delayed until at least November. Traffic in the area is expected to be affected for up to three months. Work in the intersection of Ann Arbor Trail and Sheldon is likely to shut down traffic for a brief period of time. After that, intermittent lane closures will be conducted by county officials along the stretch of the project.

Hot stoves

Members of the Salem High School Culinary Arts team said before competing in the state competition that winning a national championship didn't matter, all they wanted was to go to Florida for the contest.



They get their chance now, after winning the state competition earlier this month in Grand Rapids, where their recipe for lamb shank, salad and chocolate and strawberry-passion fruit mousse won them first-place honors from the Michigan Restaurant Association. The public can taste food prepared by students in the culinary arts program at the Rock Cafe, located in Salem High School. It's open 10:30 a.m. to noon Tuesday-Friday.

Farmers market

The 2004 Plymouth Farmers Market is expanding, Plymouth Community Chamber of Commerce officials announced this week. The market, held every Saturday starting May 8, features a variety of fresh produce, baked goods, flowers and plants, fresh herbs, dried flowers, hot coffee and lemonade. This year, it expands to both sides of Penniman between Main and Union. Market hours are 7:30 a.m. to 12:30 p.m., with the exception of the Saturday of Fall Festival (Sept. 11).

Partnership hopes to turn page on reading

BY BRAD KADRICH
STAFF WRITER

There's a popular advertising campaign on television that says, "Reading is fundamental." A new program being pushed by Plymouth-Canton Community Schools, the

Canton Public Library and the Plymouth District Library is hoping to get parents and children alike to focus on the "fun" part of that slogan.

The "What Are You Reading?" campaign is aimed at getting people to treat reading as an entertainment option in an age

when so many choices are available.

"It doesn't matter what you're reading, as long as you're reading," said Frank Ruggirello, director of community relations for Plymouth-Canton schools.

PLEASE SEE READING, A4



Community partners in reading.
Canton & Plymouth

What are you reading?

A Jim of all trades

Real estate mogul lives life with hands in many pies

BY TONY BRUSCATO
STAFF WRITER

Jim Courtney says he doesn't gamble, he takes calculated risks. And not too many people can argue his success rate.

Courtney is a top real estate agent and broker, a stand-up comedian, an executive producer of several movies and a world-class poker player.

Not bad for someone who quit high school twice before graduating and was too poor to go to college.

"I've tried a lot in life, and not every one was a winner," said Courtney, 59, of Plymouth Township. "But, I've won more than I've lost."

Courtney has used life's experiences and his business expertise to meet people, many who have become his business partners.

"You never know where a good idea or person will

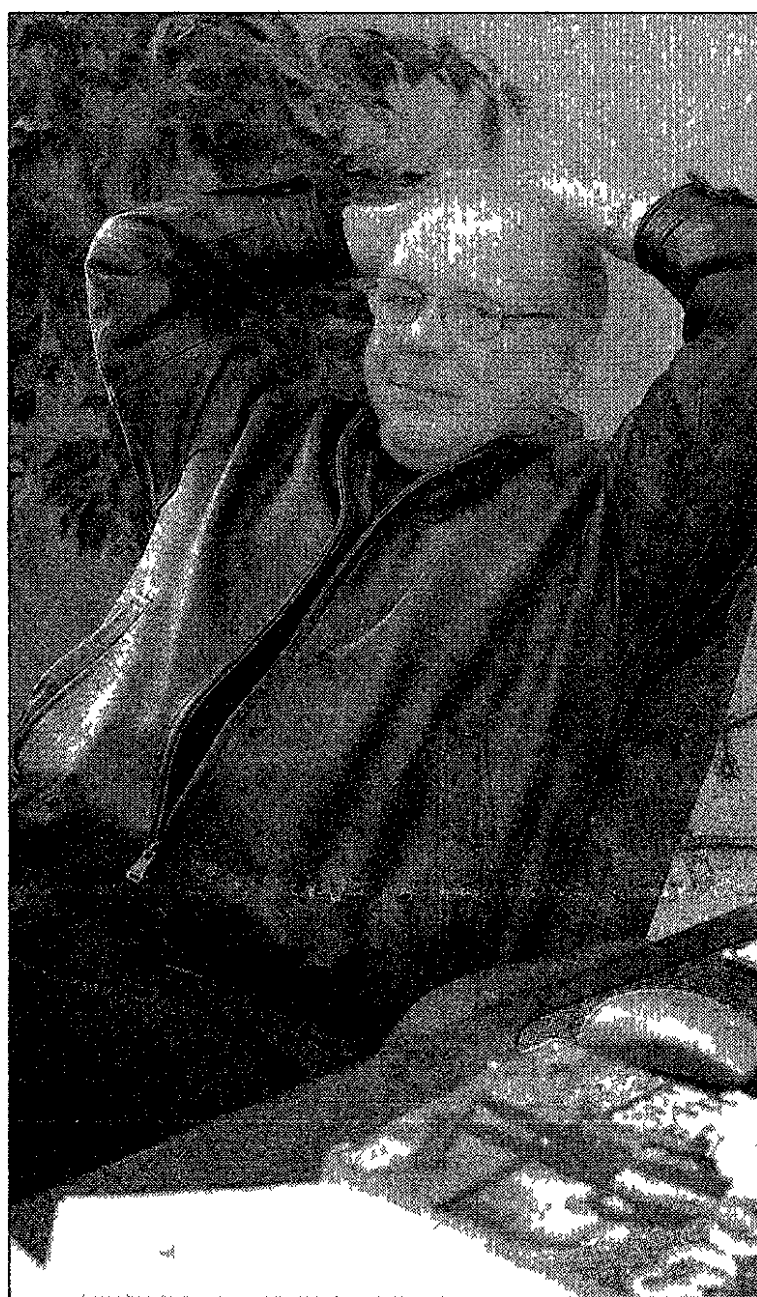

PLEASE SEE JIM, A8
Jim Courtney has tried his hand at a lot of things, and been successful at most of them, throughout his life.

Compari's a double winner

The readers have spoken in the Plymouth Observer, and that's an especially good thing for the folks at Compari's.

The downtown restaurant was the only multiple winner in the 2004 Best of Plymouth readership survey conducted in the paper over the last couple of months. Hundreds of readers responded to the poll, and Compari's won in both the "Best Pizza" and "Best Restaurant" categories.

"That's wonderful," Compari's owner Frank Yaquinto said. "I'm somewhat shocked, and I'm certainly proud of our staff and crew. I'm especially happy to see our customers enjoy the restaurant."

Yaquinto, who has owned a pizzeria in Dearborn since 1969, said the key to Compari's pizza is the manner in which it's put together, which is the same as he's been doing since he got into the pizza business. "Our pizza is truly a throwback to the 60s," he said. "We make them the same way we've been making them for 30 or 40 years. We've been in the pizza business forever and we haven't changed a thing."

He credits the restaurant's overall success — and popularity with readers — to its serv-

ice-oriented and family atmosphere.

"We put our best foot forward to make people feel they're our guests coming into our home," said

Yaquinto, whose nephew is the restaurant's head chef. "Our staff is very good at that. A lot of customers let us know they feel comfortable when they come in."

The Best of Plymouth survey sought winners in 10 different categories. The other winners included:

- Best Burger — The Box Bar
- Best Local Politician — Freshman state Sen. Bruce Patterson, R-Canton Township
- Best Coffee — The Coffee Bean, the tiny coffee shop on Penniman edged corporate giant Starbucks by a single vote
- Best Local Landmark — Kellogg Park
- Best Barber/Hair Salon — Mel's Golden Razor
- Best Bar — A tie between Kellogg Park and Plymouth Township Park
- Best Ice Cream — Dairy King, in the survey's widest margin of victory
- Best Bar — Sean O'Callaghan's Pub

Upcoming editions of the Plymouth Observer will feature each of the winners.



Firm stamps name on safety honor

BY TONY BRUSCATO
STAFF WRITER

E&E Manufacturing in Plymouth became the first automotive metal stamping company in the state to receive the prestigious Michigan Voluntary Protection Program's STAR Award, given to companies that are committed and excel in worker occupational safety and health.

In a ceremony at the Industrial Drive plant Tuesday morning, many of the company's 280 employees watched as president and owner Wes Smith was presented the award by U.S. Labor Department Assistant Secretary for

A legislator and local CEO discuss job outsourcing. News, page A5.

Occupational Safety and Health John Henshaw.

The MVPP STAR Award is given to companies that work toward achieving safety and health excellence, and that pass rigorous tests and inspections. One condition for the STAR Award is having injury and illness incidence rates below the industry average for three straight years.

Smith said he remembers five years ago meeting with 50 employees to describe and define the corporate culture. "The first word they

identified was safety, followed by fairness, hard work and respect," Smith said. "The tangible benefits (of safety) were obvious, such as lower workman's comp rates, and higher productivity and quality from higher employee morale. Our corporate culture also defines ours, and what should be everyone's, corporate responsibilities."

"By winning this award, the E&E team shows that it deeply cares about the associates who work here and the importance of safety on the job site,"

Smith said. "These tests and inspections are incredibly thorough, and we passed them with flying colors. E&E has been, and will continue to be, a leading advocate for worker safety."

Mark Caudell of Belleville works in engineering at E&E, and said it's obvious safety is the No. 1 concern at the stamping company.

"We have people constantly looking for ways to improve safety to make sure people don't get injured," Caudell said. "I've worked at a lot of different places, and when you walk through this building you can see there are extra steps being



E&E Manufacturing owner Wes Smith (right) poses with David Hollister (center), director of the state's Department of Labor and Economic Development, and E&E's Rich Sbraglia after receiving the prestigious Michigan Voluntary Protection Program's STAR Award.

taken to make sure people don't get injured."

Carolyn Logan of Southfield has worked at E&E for seven years in the packaging department, and said it's like working with family. "It's a great place to work," she said. "We care

about each other around here, and look out for each other's safety."

State Rep. John Stewart (R-Plymouth Township) said he's nominated E&E to be named the No. 1 manufacturing company in the state by the Michigan Manufacturers Association.

MRS. FIELDS COOKIES
Hiring for full and part time help. Must be able to work days, nights.
Great Response! We hired 2 people right away! K Livonia
1-800-579-SELL
PUT OUR CLASSIFIEDS TO WORK FOR YOU!

CONTACT US
Newsroom (734) 459-2700
Newsroom fax (734) 459-4224
Classifieds - 1-800-579-SELL
Home delivery 1-866-88-PAPER
HomeTown COMMUNICATIONS NETWORK

INDEX

Apartments	F9	Jobs	F12
At Home	C1	Movie Guide	E6
Automotive	G9	Obituaries	C7
Classified Index	F5	Real Estate	F5
Crossword Puzzle	F7	Sports	B1
For The Record	A4	Taste	D1

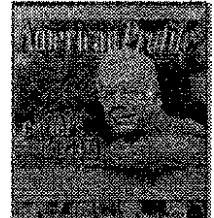

LOOKING AHEAD
American Profile
President Jimmy Carter discusses how his dogged determination to help others was formed while growing up in Plains, Ga.



Washington Mutual The Power of Yes®
HOME LOANS
We're your new neighbor... 17909 Haggerty Road • Northville • 248-374-4501

CLARIFICATION

The Plymouth YMCA Summer Camp Open House and The Healthy Kids Day location has been changed to McClumpha Park, located on Ann Arbor Trail in Plymouth Township. The event is scheduled for 2-4 p.m. April 25.

for its preschool programs for Fall 2004.

The program for 3-year-olds runs Tuesday and Thursday, the program for 4-year-olds runs Monday, Wednesday and Friday.

For more information, call Peggy at (734) 459-1358 or (734) 453-5464, Ext. 25.

THREE-DAY SALE

The Plymouth Community Chamber of Commerce sponsors a three-day sale in downtown Plymouth April 1-3.

Participating stores will offer sales on home decor, fashions, products and services. Free horse-and-carriage rides take place from noon to 4 p.m. Saturday, April 3, and a family buffet breakfast with the Easter Bunny will also be served Saturday from 9 a.m. to noon.

Pictures can be taken with the Easter Bunny from 11 a.m. to 4 p.m. Saturday and again Sunday, April 4, in Westchester Square Mall.

For more information, call the chamber, (734) 453-1540.

ARTWORK CRITIQUE

Farmington Hills artist Jeri Fellwock will display some of her own work and critique others' work during an appearance for the Three Cities Art Club from 7-9 p.m. Monday, April 5, at the Plymouth Township Clerk's Building, located at 42350 Ann Arbor Road at Lilley.

Light refreshments will be served. For more information, call (248) 262-9711.

SPRING MUD FLING

Pottery workshops for the whole family are scheduled at the Plymouth Community Arts Council during Spring break. PCAC officials are heading the annual 'Mud Fling' from 10 a.m. to noon April 13-15 as "the most fun you will have in the mud (clay) all year."

Participants can create, for example, a decorative tile or fancy cup, paint it with colored clay and the instructors from the Village Potters Guild will glaze and fire it to pick up a few weeks after the fun.

For more information call (734) 416-4278 or stop in at the PCAC, 774 N. Sheldon.

SYMPHONY GALA

The Plymouth Symphony Orchestra, under the direction of Nan Washburn, presents "Best of Broadway," the symphony's annual pops benefit dinner and auction, at 6 p.m. Saturday, April 24, at Laurel Manor in Livonia.

The concert will feature songs from favorite Broadway musicals, including selections from *Chicago*, *Cats*, *My Fair*



Lucky day

Terrri O'Brien and Joe Keller celebrate St. Patrick's Day as well as their wedding anniversary, at the Bennigan's in Plymouth.

12 and up with at least three years of instruction. Students may live anywhere in southeastern Michigan. Auditions must be scheduled in advance.

The CYO is the youth orchestra supported by the Plymouth Symphony Orchestra. In fall 2004 the CYO will have two ensembles, the Celebration Sinfonia for string, wind, brass, and percussion students and the Celebration Strings. The CYO is dedicated to challenging and inspiring students through high level ensemble training and the performance of standard and new repertoire.

The CYO is part of the Plymouth Symphony's Youth Outreach Education Program. Donations to the Symphony's No Kid without a Concert Education Campaign help fund the CYO as well as many other programs for students throughout Southeastern Michigan.

Students should prepare a piece of their choice and a scale representative of their ability. To schedule an audition or for more information please contact the Plymouth Symphony office at 734 451 2112 or by email at CelebrationYO@aol.com.

DOG JOG

The Kiwanis Dog Jog is right around the corner, scheduled this year for May 8 in downtown Plymouth's Kellogg Park.

The annual event raises money for the Plymouth Kiwanis Club and the Michigan Humane Society. Last year's Dog Jog raised more than \$6,000.

The event primarily features owners and their dogs taking part in a run or walk of approximately a two-mile course through Plymouth.

Owners solicit pledges based on completion of the course. There is a fee that covers the Kiwanis Club's costs and programs.

Participants receive a T-shirt, a dog bandana and a bag of items for the pets.

Awards are given in categories such as best-dressed dog, biggest tail, owner/pet look-a-likes and other categories judges see as significant.

Lady, and *The Music Man*. Prior to the concert guests can enjoy dinner catered by Laurel Manor.

Throughout the evening the Plymouth Symphony League's annual silent and live auctions will take place. Items to be auctioned include a weekend condo stay near Sleeping Bear Dunes, a diamond ring courtesy of Showroom of Elegance, a VIP tour of the Detroit Zoo, dinner at numerous restaurants in the area, and a chance to conduct the Plymouth Symphony U-of-M and MSU fans will also have the chance to outbid each other to hear their fight song performed by the symphony.

This event is sponsored by Target and supported by the Plymouth Symphony League and the Michigan Council for Arts and Cultural Affairs, a partner agency of the National Endowment for the Arts. The

invitation sponsor is Mike and Mary Gladchun, RE/MAX on the Trail.

Tickets for the event are \$75 for adults and \$35 for children. Table sponsorship for groups is also available. Tickets must be purchased in advance. For tickets, season subscriptions, or more information, please contact the symphony office at (734) 451-2112 or at plymouthsymphony@aol.com.

YOUTH ORCHESTRA AUDITIONS

The Celebration Youth Orchestra holds auditions for the 2004-05 school year Saturday, May 15, at Evola Music, 7170 North Haggerty Road in Canton.

Auditions are open to string students ages 9 and older with at least one year of instruction and wind, brass, and percussion students ages

PLYMOUTH Observer
www.hometownlife.com

HOW TO REACH US

Susan Rosiek
Executive Editor
(734) 953 2100
srosiek@oe.homecomm.net

Keely Kaleski
Filter Editor
(734) 953 2105
kkaleski@oe.homecomm.net

Hugh Gallagher
Managing Editor
(734) 953 2149
hgallagher@oe.homecomm.net

Frank Cibor
Retail Sales Manager
(734) 953-2177
fcibor@oe.homecomm.net

Brad Kadrich
Community Editor
(734) 459 2700
bkadrich@oe.homecomm.net

Lisa Walker-kadrich
Retail Advertising Rep
(734) 953 2168
lwalker@oe.homecomm.net

Paul Hurschmann
Photo Editor
(734) 953-2136
phurschmann@oe.homecomm.net

Newsroom(734) 459 2700 **Fax** (734) 459-4224
Sports Nightline(734) 953 2104
Circulation/Customer Service .. 1 888 PAPER (866 887 2737)
Classified Advertising1 800 579 SELL (7355)
Display Advertising(734) 953 2153

To purchase page and photo reprints go to www.hometownlife.com/reprints
For more information contact (734) 591-0500

Circulation Business Hours/Subscription Rates
Monday-Tuesday Wednesday-Friday 8.30 a.m. to 5 p.m.
Thursday 8.30 a.m. to 7 p.m.
Sunday 8 a.m. to noon

If you missed a delivery please call by 6 p.m. Thursday and 11 a.m. Sunday

Carrier Delivery	Mail Delivery
One year \$51 00	One year (in county) \$72 95
For senior citizen rate please call 1 866 887 2737	One year (out of county) \$108 95

POSTAL PERIODICAL REQUIREMENTS
The Plymouth Observer Publication NO USPS 436 360 Published every Thursday and Sunday. Periodical postage is paid at Livonia, Michigan 48150.

A HomeTown Communications Network publication
36251 Schoolcraft Livonia MI 48150

CBC MPA SN GNN
Circulation Detroit New paper Network

Elegant by Name – Affordable by Choice

To people who've always wanted to negotiate for a better price, but were afraid to try.

At our **"MAKE A DEAL WITH THE BOSS" SALE**, we want you to negotiate with us for that fine jewelry you've had your eye on for so long.

"MAKE A DEAL WITH THE BOSS"

FRIDAY & SATURDAY ONLY
MARCH 26-27
9:30 AM - 8:00 PM

Sale excludes previous purchases, loose diamonds, repairs & special orders.

FREE Two-Hour CRUZ LIMOUSINE RIDE... with your diamond ring purchase.

Hundreds of Diamond Bracelets, Semi-Mountings and Gold Chains & Bracelets
14K, 18K, & Platinum Mountings • One-of-a-Kind Items • Free Gift Wrap

Up to 12 Months Same as Cash (Upon Approved Credit)

Showroom of **ELEGANCE** FINE JEWELRY
www.showroomofelegance.com

Hours Mon Tue Wed Fri Sat 9:30-6:00 Thu 9:30-8:00
CANTON: 6018 Canton Center Road (North of Ford Road) • (734) 207-1906

This Easter come celebrate the resurrection of our Savior and the birth of a brand new church.

Harvest Bible Church invites you to join us
Easter Sunday, April 11 at 10:30 am
at the Elks Lodge in Plymouth
41700 Ann Arbor Rd. East, Plymouth

Come explore a service where the Bible is passionately, yet compassionately preached and practically applied to your everyday life. Come see that Easter is full of rich meaning for your life! Discover, on Easter Sunday, how faith in Christ can give you new hope for today and tomorrow. We're saving a seat for you!

Not just another Church!
Be prepared to hear the whole truth delivered with great conviction and compassion.

Get ready to experience God in a fresh, new way. Worship services are contemporary and relevant, seeking to lift high the name of Jesus Christ.

Professional, well-staffed nursery and children's ministries your kids will love!

Left to right: (Back Row) Krstine & Associate Pastor Jarne Langan. (Front Row) Madeline & Elson Langan, Kaylee, DJ & Stacey McChes.

HARVEST Bible Church
Elks Lodge • Plymouth, Michigan • 734-459-7795
"Where the Word of God is passionately preached without apology and people are loved unconditionally."

Madonna hosts wine-tasting, dinner, auction for scholarships

Madonna University's 16th annual Scholarship Dinner and Wine Tasting Auction Gala will be Friday, April 23, at Laurel Manor in Livonia.

"This is the main fund raiser Madonna University holds each year to support student scholarships," said Sr. Rose Marie Kujawa, CSSF, Madonna University president. "Our mission is to make education accessible to a diverse student body. This auction affords students the opportunity to complete their college degree which otherwise might not have been possible."

Scholarships help many students, including Myra Porter, a sophomore in the education program.

More than 50 new wines from Australia, personally selected by John Jonna of Merchants Fine Wines, will be among the evening's highlights. The wines will be accompanied by elaborate hors d'oeuvres and a sit-down dinner presented by the chefs of Laurel Manor for discriminating diners and wine connoisseurs. The general chairs are Special Drill & Reamer Corporation President Michael Obloy, chairman of the Madonna University board of trustees, and his wife, Jo.

The silent auction focuses on fine jewelry pieces with several "right-hand rings," including the latest trend in uniquely colored diamonds, such as canary yellow, turquoise and cognac colored diamonds.

During the live auction, guests will be impressed with the enthusiasm of auctioneer Ed King of Clare, Michigan. John Jonna will conduct the wine auction and will share his expertise in the art of fine wine enjoyment.

One lucky winner will have a choice of either a fully-equipped 2004 Chevrolet Corvette two-door coupe, courtesy of Madonna University and Tennyson Chevrolet in Livonia, or \$25,000 cash. Tickets are currently on sale at \$200 and



The 2004 Corvette shown at the Catholic Parishes Federal Credit Union on Five Mile Road is part of a raffle to benefit Madonna University students through scholarships. The winner will be drawn at Madonna's Scholarship Dinner and Wine Tasting Auction Gala April 23. Pictured (standing, from left) are auction general chairs Jo Obloy and Michael Obloy, Kit Tennyson of Tennyson Chevrolet, and Peter Bagazinski, CEO, Catholic Parishes Federal Credit Union (kneeling left) scholarship recipients Jennifer and Bill Pless and David Carey.

only 650 tickets will be sold. Tickets will also be sold at \$10 each for a "Your Choice" raffle which offers an opportunity to win one of five items, including a Kawai digital piano, diamond jewelry, an in-vehicle DVD player/LCD monitor donated by Al Long Ford of Warren or \$1,000 cash. In each raffle, the winner need not be present at the drawing that evening. Reserved seating is \$150. Open seating tickets are \$125 before April 9, after that, tickets are \$150. For more details, visit www.madonna.edu or contact Rose Kachnowski at rkachnowski@madonna.edu or (734) 432-5421.

O&E celebrates senior life at May expo

The *Observer & Eccentric Newspapers*, in cooperation with Schoolcraft College, presents a senior citizens expo — "Celebrating Senior Life in America" — Wednesday, May 19.

The event is expected to draw thousands of older adults to Schoolcraft's new Vista Tech Center on Haggerty Road, between Six and Seven Mile roads.

Businesses are invited to exhibit their services and/or products at the event, which takes place from 10 a.m. to 2:30 p.m.

Sponsorships and booth opportunities are available ranging from \$2,995 to \$895. Early bird rates are in effect until April 1. Exhibitor registration deadline is April 15.

In addition to offering booth

space, exhibitors will also appear in a special senior citizens expo section to be distributed Thursday, May 13, in more than 200,000 newspapers — 15 editions of the *Observer & Eccentric*, plus four *Hometown Newspapers* (Northville, Novi, South Lyon and Milford).

Statistics show that the mature consumer has the highest net worth of any age group — more than \$7 trillion, according to *The Media Audit*, January 2004 survey.

Health care service and equipment providers, along with financial firms, Schoolcraft College Music Department, travel and leisure businesses and others, are invited to participate in this event.

"This expo celebrates the

active, vital older adult who makes choices about health care, housing, investments and travel," said Cathy Young, promotions manager for the O&E.

Thousands of seniors are expected to attend the event and view the products and services on display. Lunch will be available at a charge for those attending and the day will be filled with special giveaways. It's a great opportunity also for baby boomers to see what services may be available for their parents.

Free parking is available and golf carts will provide a shuttle from the parking lot to expo entrance.

More information is available online at www.hometownlife.com or contact Young at (734) 953-2155 or by e-mail at cyoung@oehomecomm.net.



Shannon Durkin, 17, and Amber Skupski, 18, both from Plymouth Township, work on a mural for House of Bread in Plymouth Township.

Wall to wall

Bread store rises with students' painting

BY TONY BRUSCATO
STAFF WRITER

Two budding artists from Plymouth Township are getting firsthand experience, producing a giant mural for the new bread store in the Busch's Shopping Center at Five Mile and Sheldon.

"All of the House of Bread stores have a mural of a wheat field in them," said owner Mark Denis.

"We're all about getting into the community, so I figured why not have someone in the community do it."

Denis gave a call to the Plymouth-Canton Educational Park and Starkweather Education Center, and the two Salem High School seniors applied for the job.

I heard about it in school from my drawing teacher, so I decided to check it out, said Amber

Skupski. "I've never done anything like this before. I asked Amber if I could help her," said Shannon Durkin.

"We took turns sketching it out, and he (Denis) told us which one he liked."

The two artists first had to sketch the mural, which is 6 1/2 feet high and 24 feet wide.

Shannon does much of the work at the top on a ladder, and I do a lot at the bottom, said Skupski.

As of this week, with an April 5 target date looming, the mural was about a third complete.

"We had to step back a few times to make things bigger or smaller," said Durkin.

"I think it's coming together pretty good so far."

While Skupski said she's painting the mural for fun, Durkin is planning a career

as an artist. "I think this will look great in my portfolio, she said."

"I'm going to Central Michigan for a couple of years, and then on to London to become a fashion illustrator."

Denis said he's pleased with what he's seen thus far on the wall of his yet-to-be-opened store.

"We talked about the concept and I showed them some ideas I had, and they came back with a couple of sketches," said Denis.

"We revised them a bit, and here they are. They're doing a good job."

"I'm sure they want it to be good because their names will be on it," he said.

"It will be here for years and years to come."

tbruscato@oehomecomm.net
(734) 459-2700

Flexsteel Sit Back & Relax Sale

Relaxation — Precise on-engineered wood frame construction, guaranteed for life.

Support — Back padded with supportive polyurethane foam and polyester fibers.

Comfort — Highest level foam with polyester fiber cushion, guaranteed for life.

Patented — Padded up-ward reclining seat frame feature a lifetime warranty.

Flexsteel
America's Seating Specialist

Help make your dreams come true with a flexsteel recliner starting at **\$399⁹⁹**

Some Models Available in Leather

Laurel FURNITURE, INC.

584 W ANN ARBOR TRAIL • PLYMOUTH • (734) 453-4700

FLEXSTEEL FINE FURNITURE BEGINS ON THE INSIDE

Open Daily 9:30-6
Thurs & Fri til 9 Sat til 5:30

14TH ANNUAL BOAT & FISHING SHOW

FREE SEMINARS MARCH 26-27-28

FRI 12-9 • SAT 10-9 • SUN 10-6

ADMISSION ONLY \$2.00 PER CARLOAD!

FEATURING

BOATS • TRAILERS • MOTORS • BOAT COVERS • TACKLE
BAIT SHOPS • MARINE SUPPLIES • BOAT STORAGE
CHARTER SERVICES • MARINAS • ENGINE REPAIR
ACCESSORIES • SONAR & DEPTH FINDERS AND MORE!

FREE SEMINARS

HOSTED BY MICH STEELHEADERS
Huron Valley Chapter

LAKE MICHIGAN SALMON & TROUT
By Capt Jim Karr SATURDAY (Noon & 4PM)

WALLEYE TROLLING METHODS
By Capt Andy Kuffer SATURDAY (2PM & 6PM)

LAKE MICHIGAN SALMON & TROUT
By Capt Mike Steffes SUNDAY (Noon & 3PM)

LAKE ERIE & DETROIT RIVER WALLEYE TROLLING METHODS
By Capt Mike K SUNDAY (1:30 PM & 4:30PM)

THREE BIG DAYS!

Gibraltar TRADE CENTER, INC.

1-75 & EUREKA RD. (EXIT 36)
TAYLOR, MI 734-287-2000

VISIT US ON THE WEB: WWW.GIBALTARTRADE.COM

FREE

FRIDAY ADMISSION

With This Coupon
FRIDAY MARCH 26TH ONLY

Fifth Third Bank MaxSaver Money Market Account

Your number is up. Way up.

MaxSaverSM Money Market Account

2.40% APY

Balance	APY
Balances over \$25,000	2.40%
\$10,000 - \$24,999	2.00%
\$5,000 to \$9,999	1.00%
Less than \$5,000	0.50%

A high rate of return, FREE Internet Banking and Bill Payment, FDIC insurance and easy ATM access. What better way to earn a great return on your savings? For a limited time, Fifth Third Bank is offering its customers a great rate on our MaxSaver Money Market Account.

Let us take a look at your financial profile and show you how easy it is to open a MaxSaver Account. Just one of the reasons why Fifth Third is *the only bank you'll ever need.*

CALL 1-877-579-5353 | WALK-IN Over 960 Locations
VISIT www.53.com

Fifth Third Bank

Working Hard To Be The Only Bank You'll Ever NeedSM

As of 3/15/04 the Annual Percentage Yield (APY) for balances over \$25,000 is 2.40% for balances of \$10,000 - \$24,999 the APY is 2.00% for balances of \$5,000 - \$9,999 the APY is 1.00% for balances less than \$5,000 the APY is 0.50%. Rates may change after account is opened. Fees may reduce earnings. Accounts must be opened with funds not currently on deposit with Fifth Third Bank. \$25 fee if account is closed within 180 days of opening. Offer requires a funded checking account. Offer valid at Eastern and Western Michigan locations only. Limit one account per household. Fifth Third Bank reserves the right to refuse any deposit. Not available for commercial and non-profit accounts. Maximum account balance is \$500,000. Fifth Third Bank and Fifth Third Bank are registered service marks of Fifth Third Bancorp. Member FDIC.



OE08198572

READING

FROM PAGE A1

"There are a million things for kids to do these days. We want to encourage people to pick up a book and read."

"What Are You Reading" is an off-shoot of the school district's new language arts curriculum, launched last fall after three years in development. The curriculum, which is in line with state standards and benchmarks, is designed to help students become better readers, which will, teachers believe, help them improve their math, science and social studies skills.

"Language arts is the largest content area," said Penny Joy, the district's coordinator for language arts and social studies. "If you integrate language arts into other areas of the curriculum, they'll be reading other materials which will also improve their language arts skills."

According to proponents of the program, even short stints of reading can help students achieve greater success

'We're trying to get people to make reading less of a 'task.'

Susan Stoney
public relations specialist

in school

Kids who read as little as 11 minutes a day significantly improve their scores on standardized exams," said Kevin Scanlon, the Canton Public Library's teen librarian.

But in addition to helping students advance their school skills, "What Are You Reading" seeks to promote reading as a viable recreational option. Both libraries feature book discussion books, and the school's curriculum center has a shelf where people can donate and borrow used books. The trick is to get people to take advantage of them.

"We're trying to get people to make reading less of a 'task,'" said Susan Stoney, public relations specialist at the Plymouth District Library. "We're trying to get people to look at reading as entertainment."

The two-year "What Are You Reading" program will push reading in several ways. Posters featuring school Supt. Jim Ryan have appeared asking the question, and the committee hopes to bring in authors as guest speakers to various library and other civic functions.

The committee will also work with the district's Educational Excellence Foundation to provide classroom libraries.

"Research is very strong that books must be readily accessible," Joy said. "The power of having books in the classroom is very strong."

Since the committee wants to focus not only on students, but on all people, the libraries were obvious partners for the project, because they tend to reach a wider audience.

"Libraries have the capacity to expand this virtually from birth to death," Stoney said. "We have programs where we get parents to read to 3-month-olds, and we take books to senior (citizen) centers. We're trying to expand the use of books to all ages."

bkadr.ch@oe.homecomm.net | (734) 459-2700

FOR THE RECORD

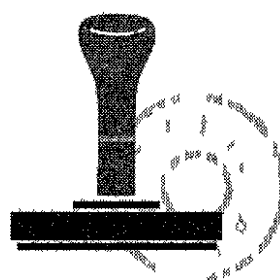

For the Record appears in every edition of the Observer & Eccentric Newspapers.

Complete paid obituaries can be found inside today's At Home section in Passages on page C7.

DEATHS

- B**
Jacqueline Barnes, 72, of Lake Orion died March 22.
William L. Bland, of Pontiac died March 19.
Victoria Brown, 45, of Plymouth died March 22.
- C**
Dennis Courtney, 56, of New Hudson, died March 21.
- D**
Laura K. DeOrlow, formerly of Birmingham, died March 19.
Michael J. DeVonce, 79, of Troy, died March 18.
- G**
Robert H. Gotshall, 76, died March 16.
Stella M. Groth, 71, of Livonia, died March 22.
- J**
Keith Carl Johnson, 50, of Plymouth, died March 17.
Royce T. Joier, 19, of Southfield, died March 19.
- L**
Lois Marion Lane, 83, of Plymouth, died March 15.
Sister Mary André Lytle, 96, of Farmington Hills, died March 21.
- M**
James Mech, 70, of Farmington Hills, died March 23.
- R**
Sister Mary Victorine Rapin, 96, of Farmington Hills, died March 21.
Carl F. Rentschler Jr., 78, of Leonard, died March 20.
- S**
Walter C. Sanders, 67, formerly of Troy, died March 21.
Richard A. Schlegel, 78, formerly of Beverly Hills, died March 21.
- T**
Maurice S. Teeter, 77, died March 18.
- V**
Raymond Verrot, 72, of Bonita Springs, Fla., died March 16.
- W**
Elizabeth L. Warner, 94, of Bloomfield Hills, died March 1

BIRTHS

Aidan Browning
Michael and Jennifer Browning of

FIRE RUNS

The Plymouth Community Fire

POLICE BLOTTER

Sometime between 7 p.m. March 17 and 5:30 a.m. March 18, someone broke into Majeske Machine on General Court and stole some 42 20 pound metal forging plates. The plates had been stored in a wood crate in front of the business. No other items were discovered missing.

Someone stole a set of golf clubs from a garage on Plymouth Ridge.

The clubs, valued at some \$1,000, were left in the open garage. There was no sign of forced entry.

Department responded to the following runs between March 17-23:
 ■ Tuesday, March 23 – Commercial rescue runs on Port, on Haggerty and on Galleon, residential rescue runs on Heritage on Newport on Northern on Simpson and on Manton, downed wires on Penniman, industrial rescue runs on Sheldon on Galleon and on Plymouth Road, vehicle fire on Sheldon, special run on Haggerty.

■ Monday, March 22 – Residential rescue runs on Pinetree on North Territorial, on Sheridan and on Eckles, vehicle accident at Beck and Ann Arbor Trail.

■ Sunday, March 21 – Investigations on Firwood and on Northview, smoke investigation on Sheridan, residential rescue runs on Northville Road on Sycamore, on Mill and on Red Maple, commercial rescue run on Main.

■ Saturday, March 20 – Residential rescue runs on Pinewood on Breckenridge, on Hilltop and on Sheridan, smoke investigation on 5 Mile, commercial rescue run on Penniman.

■ Friday, March 19 – Residential rescue runs on Burroughs, on Roosevelt Court on Ann Arbor Trail and on Jener, investigation on Richard, smoke investigation on Penniman.

■ Thursday, March 18 – Rescue run on Lakeview, south of Hines, residential rescue run on Haggerty, commercial rescue run on Ann Arbor Trail, rescue run at a public building on Ann Arbor Road.

■ Wednesday, March 17 – Rescue run at public buildings on 5 Mile and on North Territorial, residential rescue runs on Pinetree, on Ann Arbor Trail and on A Drive, vehicle fire at Ann Arbor Road and Haggerty, commercial rescue run on Main, rescue run at Sheldon and Judson.

the passion.
you will have questions.
march 21 // answers.
march 28 // more answers.

Please recycle this newspaper

10:30 am	DOWNTOWN PLYMOUTH CENTRAL MIDDLE SCHOOL		SOLID ROCK A BIBLE CHURCH FOUNDATION FOR THE HEART, MIND AND SOUL solid_rock@ameritech.net 0608 9543
	CHILD CARE PROVIDED FOR MORE DETAILS CALL 734 455 7711		

LA-Z-BOY

Leather made better!

Special Purchase Savings on Genuine La-Z-Boy® Leather!

We received special savings and now you can save like never before on these new La-Z-Boy® styles in luxurious Leather Finesse® with genuine top grain leather where your body touches and perfectly matched vinyl on the back and side panels.

12 Months No Interest!*

Since 1933

Walker/Buzenberg
fine furniture

240 North Main Street • PLYMOUTH • 734-459-1300
 Mon, Thurs, Fri 10-9 • Tues, Wed, Sat 10-6, Sun 1-5
 *Financing With Credit Approval
 www.walkerbuzenberg.com
 0608161922

GO ON A CAMPING TRIP— to State Street.

pre-season sale:

Camping Equipment Dirt Cheap.
Saturday, March 27

Manufacturer's Reps on hand to present the latest designs and answer questions.

plus:

Demonstrations All Day
 11-12pm: How to use a GPS
 12-1pm: Water Filters
 12-3pm: Cooking and Food Tasting
 Door Prizes

BIVOULAC
 Quality Outdoor Clothing & Equipment

336 S. State Street • Ann Arbor • 734.761.6207
 Mon-Fri: 10-9 • Sat: 10-6 • Sun: 12-5

Patagonia • Osprey • NorthFace • Marmot • Gregory • MSR
 Vasque • Asolo • Black Diamond • Merrell

0608196328

Find your favorite recipes each
Thursday in Taste

District disconnects cellular phones

BY TONY BRUSCATO
STAFF WRITER

Cell phones and other electronic communication devices used by students in Plymouth-Canton schools, on school property and at after-school events must be turned off and put out of sight

That comes after the Board of Education Tuesday night passed new regulations, in accordance with state law, which also call for prohibition of cell phones, especially those with picture-taking capabilities, in restrooms and locker rooms

Trustee Richard Ham-Kucharski expressed concerns that students with picture phones could copy tests given in the morning and pass them on to students taking the same test later in the day

"That sucks," said Tamara Shurey, 17, of Plymouth Township, who was meeting her dad after classes in the Salem High School parking lot, with a cell phone in her hand

"I use my cell phone a lot, especially during passing time. I call my mom to tell her what happens at school, or when work leaves a message to cover shifts," said Shurey. "It will be an inconvenience for me"

Shurey's dad, Jack Deakins, said he likes the new rules regarding cell phone usage by students

"I don't think they should be using cell phones during school hours for personal calls," he said. "I think they should be able to carry them, as long as they're out of sight, in case of

'I don't think they should be using cell phones during school hours for personal calls. I think they should be able to carry them, as long as they're out of sight, in case of emergencies.'

Jack Deakins
parent

emergencies

"During those times, they should be able to use them to call parents and let them know they're safe," added Deakins. "These are changing times"

Leaving class for the day, the first thing 14-year-old Abby Finkelstein of Canton did was reach for her cell phone

"That's not cool," said Finkelstein after hearing of the new regulations. "I use my cell phone to call my friends during lunch and passing time. I've never been caught with it before. I usually put it on vibrate during class"

Students say cell phones ringing during class isn't a problem as most kids put them away. Violators will have their cell phones confiscated

The school administration acknowledged that students will be able to get permission to make calls in the school office, and coaches will have the discretion to allow students to call home for rides or when events are running late

Legislator, Plymouth CEO blast job outsourcing

BY TONY BRUSCATO
STAFF WRITER

Moments before receiving the prestigious Michigan Voluntary Protection Programs STAR Award for exemplary safety and health excellence in the workplace, E&E Manufacturing president and CEO Wes Smith took time to take a shot at those companies who are sending manufacturing jobs overseas

The ultimately responsibility of a corporation should be to its community and employees,"

said Smith. "Many companies still provide jobs to Americans, still contribute to charities and invest in their communities. I believe as a business leader this is our calling"

"Unfortunately, today an increasing number of CEOs feel that they only have an obligation to shareholders. What that CEO is saying is that their ultimate responsibility is to themselves"

"Short term thinking and meeting Wall Street's quarterly expectations is the fuel that feeds the raging fires of

outsourcing," said Smith. "As a company, Wall Street rewards you because you have just lowered your cost of inputs. As a nation, however, you have made yourself weaker because you have moved productive capacity"

Congressman Thaddeus McCotter, on hand to honor E&E for receiving the STAR Award, likened the outsourcing of manufacturing jobs to the dot com boom and bust, and said he'll be working hard to reverse the trend

It has come to my

realization that any trade agreement must promote democracy in other countries, have real opportunity for American citizens and provide for the national security of this country," said McCotter

"If all three are not met in those agreements, it shouldn't be passed because in the end it will be a short-term Wall Street gain and a long-term loss for the people of this country"

tbruscato@oe.hometownlife.com
(734) 459-2700

New Main Street Bank opens for business in Northville

Main Street Bank has opened for business in Northville

The announcement was made recently by Rick Shaffner, chairman and CEO, and Audrey Mistor, president and COO. Main Street Bank received its State Banking Charter from the state's Office of Financial and Insurance Services March 1. In addition, the Bank's deposits are FDIC

insured. The bank is located in the heart of downtown and will be the only community bank based in Northville

"Main Street Bank will be uniquely positioned to support the community, given its local management, directors and investors," Shaffner said. "Through our active involvement in the community and our local relationships, we will be better equipped to support

the financial needs of the area." Six of the bank's nine directors, including Shaffner and Mistor, are Northville residents. Mistor is a 23-year banker who believes in creating a relaxed, friendly and attentive environment at Main Street Bank

"At Main Street Bank, it's all about service," she said. "We are in a position to offer products and services that will rival,

if not best, the big guys and we'll be able to do it with a hometown, personal touch. Because we are a hometown bank, we can respond to our customers' needs quickly and directly." The bank is located at 201 E. Main Street, and is open 9 a.m. to 5 p.m. Monday-Thursday, 9 a.m. to 6 p.m. Friday and 9 a.m. to noon Saturday. Call (248) 449-3700 for more information

Plan your weekend activities each Thursday with Filter



THINKING ABOUT CENTRAL AIR CONDITIONING? LENNOX. FREE ESTIMATES (734) 525-1930. Our 30th Year! UNITED TEMPERATURE 8919 MIDDLEBELT • LIVONIA

RESEARCH ON HEMOPHILIA

- Are you an **Adult** between the ages of 18 to 40 who has hemophilia A?
- Do you also infuse yourself with product?
- Are you a **Parent or Caregiver** of a child with hemophilia A?
- Do you also infuse your child with product?

If you are one of the persons described above you may be able to participate in an interview about hemophilia treatment methods.

Participants will be reimbursed \$150 for their time.

For more information about this study, please contact SHIFRIN-HAYWORTH AT 1-800-559-5954

SKATING STATION

Pre-School LUNCH & SKATE with the Easter Bunny! April 1 10 am - Noon \$6.00 (Parents and Children 6 & Under)

Includes admission, skate rental, hot dog, snack, and drink! Push Toys & Strollers Welcome!

Call for more information 734.459.6400 www.skatingstation2.com 8611 Ronda Drive (Off Joy Road) Canton

We have "No Problem" saving you money.

When you insure both your car and home with us, through Auto-Owners Insurance Company, we'll save you money! Stop in, or call us today for a "No Problem" insurance check up.

Auto-Owners Insurance
Life Home Car Business
The No Problem®

C. L. Finlan & Son Inc.
481 S MAIN STREET
PLYMOUTH MICHIGAN 48170
734-453-6000

verizonwireless
We never stop working for you®

Talk all you want it's absolutely FREE

Introducing **in**-NETWORK CALLING

Call any of our 36 million Verizon Wireless customers anytime, anywhere from the National IN-Network Coverage Area without worrying about the minutes. And it's absolutely Free.

With 1 or 2 year Customer Agreement on an America's Choice Calling Plan \$39.99 or higher.

Are you in?

Buy One Kyocera SE47 \$49.99

Get 3 Kyocera KX414s FREE

AND THE NATION'S MOST RELIABLE WIRELESS NETWORK

Get everyone you know **in**. Get all the credit!

Refer friends and EARN UP TO A \$100 bill credit. The more friends you refer, the more you talk for FREE.

Log on to verizonwireless.com/refer for referral credit details.

CALL 1.877.2.BUY.VZW CLICK vzwshop.com/in

WIN the Are you in? Sweepstakes!

Go to www.verizonsweeps.com/print Brought to you by Verizon Wireless and LG

Enter at www.verizonsweeps.com/print for the chance to win your choice of three awesome Grand Prizes featuring state of the art multimedia and appliances packages. Also get the chance to win one FREE LG VX 6000 camera phone every day.

VERIZON WIRELESS COMMUNICATIONS STORES

ANN ARBOR 2570 Jackson Ave (Next to Blockbuster) 734 769 1722	DEARBORN (CANTON) Fairlane Mall (3rd Floor Next to Sears) 313 441 0168	LAKE ORION 2531 S Lapeer Rd (Orion Mall 2 Miles N of the Palace) 248 393 6800	SOUTHFIELD 28117 Telegraph Rd (South of 12 Mile Rd) 248 358 3700	TROY 1913 E. Big Beaver Rd (Troy Sports Center) 248 526-0040
COMING SOON AUBURN HILLS Great Lakes Crossing Mall 313 869 7392	DETROIT 14126 Woodward (Model T Plaza) 313 869 7392	NOVI 43025 12 Mile Rd (Twelve Oaks Service Dr North of Sears) 248 305 6600	WESTLAND 20128 W 8 Mile Rd (Baseline Plaza just west of Evergreen) 248 357 1558	WESTLAND 35105 Warren Rd (SW Corner of Warren & Wayne Rds) 734 722 7330
BRIARWOOD MALL (In Sear's Wing Near Center Ct.)	FARMINGTON HILLS 31011 Orchard Lake Rd (S.W. Corner of Orchard Lake Rd & 14 Mile Rd) 248 538 9900	PONTIAC/WATERFORD 454 Telegraph Rd (Across from Summit Place Mall) 248 335 9900	STERLING HEIGHTS 45111 Park Ave (M 59 & M 53 Utica Park Plaza) 586 997 6500	WAL-MART LOCATIONS Port Huron 4475 24th Ave 810 385-1231
BRIGHTON 8159 Chalis Suite C (Off Grand River in front of Target) 810-225 4789	FENTON 17245 Silver Pkwy (In the Sear's plaza) 810 629 2733	ROCHESTER HILLS 3035 S Rochester Rd (At Auburn Rd) 248 853 0550	WARREN 29240 Van Dyke 586 751 0747	White Lake 9190 Highland Rd 248 698-0043
CANTON 42447 Ford Rd (Corner of Ford & Lilley Rds Canton Corners) 734-844 0481	GRAND BLANC 12621 S Saginaw St. (In Grand Blanc Mall) 810 606 1700	ST CLAIR SHORES 26401 Harper Ave (At 10 1/2 Mile) 586-777 4010	WAL-MART Lakeside Mall (Lower Ct. play area)	WAL-MART Lakeside Mall (Lower Ct. play area)

AUTHORIZED RETAILERS
Equipment offer and Worry Free Guarantee may vary

BLOOMFIELD Global Wireless 1 888 607 1800	BRIGHTON Auto One Brighton 810 227 2808	CHESTERFIELD TWP Venture Communications 586 421 9900	CLAWSON Communications USA 248 280 6390	COMMERCIAL Cellular Source 248 360 9400	WARREN Wireless Tomorrow 248 669 1200	FARMINGTON HILLS Cellular City 248 848 8800	GROSSE POINTE Authorized Cellular 1 800-VIP Plus	HOWELL Cartronics 517 548 7705	MACOMB Authorized Cellular 1 800 VIP Plus	MADISON HEIGHTS Authorized Cellular 1 800-VIP Plus	MONROE Harkimer Radio 734-242 0806	HARKIMER TWP 734-384 7001	REDFORD Diamond Touch 313 535 1600	ROCHESTER Cellular Technologies 248 299 0008	ROSEVILLE Authorized Cellular 1 800 VIP Plus	STERLING HEIGHTS Authorized Cellular 1 800 VIP-Plus	WEST BLOOMFIELD Global Wireless 248-681 7200
--	--	---	--	--	--	--	---	---	--	---	---	-------------------------------------	---	---	---	--	---

Free Handset Software Upgrade! * 2 2 3 SEND

BUSINESS CUSTOMERS, PLEASE CALL 1.866.899.2662

RadioShack
You've got questions. We've got answers.

verizon wireless

Night & Weekend hours: Nights 9:01 pm - 5:59 am M-F, Wknds 12:00 am Sat - 11:59 pm Sun. Taxes & surcharges apply & may vary. Federal Universal Service Charge of 1.88¢ (varies quarterly based on FCC rate) & a 45¢ Regulatory Charge per line/month are our charges. Not taxes. For more details call 888 684 1888

IMPORTANT CONSUMER INFORMATION: Subject to terms and conditions of Customer Agreement, Calling Plan, rebate form & credit approval. \$175 cancellation fee per line up to \$45/mo after a 12-month term. Taxes, other charges & restrictions. \$55 activation fee with 1 year term. Cannot combine with other offers. Usage rounded to next full minute. Unused min. not available in all areas. IN-Network covers over 235 million people in the U.S. Taxes apply. Rebate takes 8-10 weeks. See www.verizonwireless.com/bestnetwork for network claim details. © Verizon Wireless 2004



OUR VIEWS

Reading program a solid initiative

In a day and age when everyone is too busy or too engrossed in television or the Internet to think of much else, we love the program the Plymouth-Canton Community Schools, the Canton Public Library, the Plymouth District Library and others are putting together. Aply titled "What Are You Reading," the initiative, part of the school district's new language arts curriculum, is aimed at getting everyone — not just kids — to pick up a book, magazine or newspaper and actually spend time reading it.

It's not that no one reads anymore. What with school reports and homework and spread sheets and work-related documents, we all spend a good portion of our time reading. But those things are required reading, items we have to peruse in order to survive in our school or work environment.

The nifty thing about the "What Are You Reading" campaign is it pushes the idea of reading for enjoyment, rather than out of obligation.

The committee forming the program, which has been kicking ideas around for nearly a year, has developed several strategies to forge the idea of reading as an entertainment option. Some are subtle — for instance, posters featuring public figures reading books and asking the central question, "What are you reading?" — while others are more substantial.

For instance, one initiative aims at getting more students to sign up for library cards, which will be music to the ears of librarians in both Plymouth and Canton. Another program calls for bringing in guest speakers, possibly authors, to speak at either school or library venues.

While pushing reading as an entertainment possibility is the primary focus, the program can also provide ancillary benefits. For instance, Kevin Scanlon of the Canton Public Library points out that studies show students who read as little as 11 minutes per day dramatically improve their scores on standardized tests.

The initiative isn't aimed just at students, though. It's aimed at everyone, including adjusting the habits of those who read consistently. Used to reading a newspaper? This program encourages you to also pick up a book. Voracious novel reader, are you? "What Are You Reading" encourages you to read a magazine.

Many people, particularly adults, think of public libraries and the first thought that crosses their minds is, "I haven't been to a library in years." This program encourages people to change that thought process. And, frankly, with the quality of the libraries in both Canton and Plymouth, it's a good idea.

Tipping fee, bottle deposits both needed

State of Michigan officials believe too much trash is coming in unchecked from outside our boundaries, while at the same time some local municipalities are being forced to make a choice between necessities such as police patrols and niceties such as curbside recycling. A diverse coalition is mobilizing behind an effort they believe can cure both ills. Senate Bill 721, recently introduced by six state senators as a means to perhaps halt the onslaught of foreign trash and provide a funding mechanism to help local governments with recycling programs.

We believe the measure is worth consideration. The bill would impose a \$3 tipping charge for every ton of trash dumped in Michigan landfills, a fee the Michigan Environmental Council, representing nearly 70 environmental groups, believes would generate some \$42 million annually for recycling programs.

The money would be deposited into a waste diversion fund local communities could tap into to save failing recycling programs. The bill is currently being debated in the Senate's Natural Resources and Environmental Affairs Committee.

Bill proponents believe, and we agree, the tipping fee would discourage at least some of the haulers who routinely use Michigan as a dumping ground.

Senate Bill 721 is actually gathering support because an effort at expanding recycling can't seem to gain traction. Environmentalists would like to see an expansion of the state's "bottle bill" to include noncarbonated drink containers such as water bottles, but such a measure drew little support at a series of Republican-sponsored public hearings.

Food retailers and bottlers make up the bulk of the opposition to expanding the bottle bill, citing the cost. Passing the tipping fee bill cures a lot of financial ills. Expanding the bottle bill eases some environmental ones.

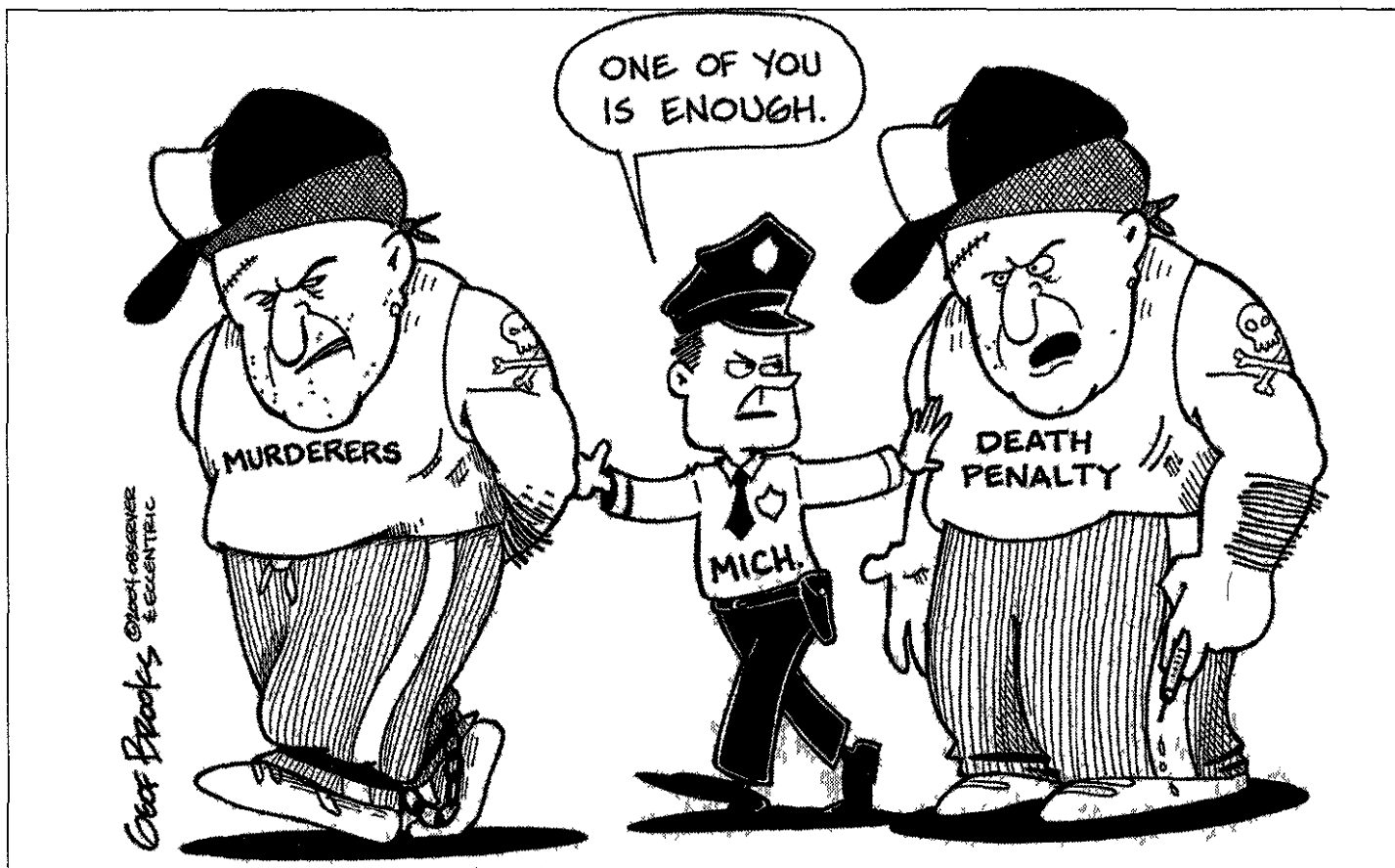

LETTERS

Simple tax solution

I would like to comment on the articles in the March 11 *Observer* regarding the 10-year anniversary of Proposal A. I am chairman of the Plymouth Tax Board of Review. My role is to be an advocate for our citizens to see they have a fair hearing and all the pertinent facts are taken into account in evaluating their petitions.

Owners of residential property will see their actual taxes (taxable value assessment) rise this year 2.3 percent as a result of the Headlee Amendment, which calls for the actual monetary increases to coincide with the annual CPI. In any event, the increase in the TV will not exceed 5 percent for any given year. All well and good, at least according to the overwhelmingly positive vote for Proposal A 10 years ago.

This formula begins to unravel when the "assessed value" is thrown into the mix, determined by sales figures over the preceding two-year period, based on city neighborhoods which are rather loosely amalgamated according to housing style homogeneity and geographic proximity. This year the range of sales went from minus-10 percent to plus-22 percent, a 33-percent spread.

Over the years, the impact of this phenomenon has been extraordinary, e.g., if you have remained in your home for the last 10 years, while you own or are paying down a mortgage to own eventually, and you have done nothing to upgrade the overall size of the home, the actual taxes will advance only by the CPI. But the AV of your home could advance dramatically. The upshot of this could be that the assessed value of your home could easily be double the taxable value.

Before you head off to the casinos with all those bucks, note what's happening. Current owners, much to their credit, are becoming aware of one of the real grabbers in Proposal A. So long as you own your house and live in it, everything is smooth.

Upon legal sale or transfer, the following year the home will be subject to "uncapping," whereupon it will be reassessed based on that year's neighborhood market analysis. The major kicker will then be that the taxable value must be adjusted to equal the resultant assessed value. All of a sudden, the actual taxes paid prior to sale or transfer could double. What the buyer thought was \$3,000 in annual taxes could actually be \$6,000 the year following sale or transfer.

Property owners are becoming aware of this wonderful characteristic of Proposal A and are increasingly not so much protesting their annual taxes but the assessed values, in anticipation of eventual sale, when an increasingly knowledgeable buying public says, "Can we really afford the mortgage payment and the huge increased tax bite?"

I would like to offer up this simple (perhaps simplistic?) and possibly temporary solution. Subject the assessed values to a similar annual guideline as the taxable values have been for the last 10 years. Then, once an actual sale has occurred, the assessed value and taxable value can be established to coordinate with the fair market value based on the sale.

In recent years, we have seen a net loss of 45,000 "young" people (18- to 45-year-olds) to other states where jobs and

affordable housing are more possible. This statistic will not improve unless we can show our young citizens it is to their advantage to remain in Michigan. I know my proposal will potentially harm the already damaged bottom line of the city budget, but I can only hope in the long run it will be beneficial to current and potential residents, and thus to the city.

Frederick J. Libbing
Plymouth

Still viable

Just because a businessman fails at a venture doesn't mean the business is not viable. Maybe it means the businessman didn't properly adapt to the community, understand his customer base and execute a properly proportioned business plan.

It's not all instant profit and gratification. Sometimes there is a long-term commitment. Some business ideas, like a family owned corner store, thrive best not as a speculative venture but as a livelihood that may only provide a decent income, a fair living and a marginally growing profit for the owners.

The facade of the Penn was renovated at a cost of around \$150,000 and never once were Preservation Tax credits applied for to help offset a good portion of the cost. Maybe the owner didn't want to be burdened by Plymouth's historic-minded laws or its downtown development mission, or maybe he didn't even realize he was an integral part of the Kellogg Park Historic District. Part of success is understanding your customer base and the community you live in.

Here is an idea — how about turning that Penn building into a small-town, single-screen movie theater with art deco verve? Wouldn't that help Plymouth remain a unique, "cool" city?

Glenn Kremer
Plymouth

Advice to Spain

On Sept. 11, 2001, my team-teacher and I were discussing the philosophies of Thomas Hobbes with our students. Ironically, a key philosophy in Hobbes' purpose for government was to keep us from the state of war.

Upon hearing about the attacks we immediately tuned into CNN and watched what was happening to our country. As the days unfolded my students stopped worrying about their differences. In those post-9/11 days we were not young, or old, or white, or black, or Democrat or Republican. In the days following the attacks the president's approval rating surpassed 90 percent and for the first time in my life I felt as though we truly were the United States.

In the upcoming days our president laid out his plan to keep America safe and the world jumped on board. Jean-Marie Colombani may have stated it best on Sept. 12, 2001, when he said, "In this tragic moment, when words seem so inadequate to express the shock people feel, the first thing that comes to mind is this: We are all Americans!" Across the world people did what they could to show their sympathy for America. Many lit candles, some prayed, most cried and still others waved our American flag beside their own and talked of unity.

The support we received from the world was heartfelt and unwavering. President Bush could even say the world was "with us."

Together the international community put down the Taliban and drove a wedge into the power structure of al Qaeda. Many good things were accomplished but the war on terrorism was not complete. Our president was given a tremendous opportunity to continue to use this cohesion to make the world safer, but instead our time leading the charge on real terrorism was, in the enduring words of Hobbes, "nasty, brutish and short."

Since the day America began its "Shock and Awe" campaign in Iraq on March 20, 2003, we have lost at least 43 American soldiers in Afghanistan during "Operation Enduring Freedom." Seven of those brave soldiers died in an explosion Jan. 29. Had we continued to focus all our resources on the main goal at hand, finding Osama bin Laden and destroying al-Qaeda, those 43 individuals may be safe at home and their mission accomplished. America and the world would have been safer than it is today. But, our President had his agenda.

According to Paul O'Neill, in the first meeting of the National Security Council the president told his council "Go find me a way to do this. This was more than seven months before the attacks of Sept. 11 and well before he and his administration would continually infer that Saddam Hussein was somehow involved in those attacks."

My suspicions arose when on the march to Baghdad our troops were used to destroy an inflammatory mosaic of President Bush's father's head, not used to search for the weapons of mass destruction that we heard so much about from Secretary Powell.

By March of last year we had entered into war with Saddam Hussein telling the world we would be made safer without him. Instead, we made Iraq the newest hotbed of terrorist growth and left our underpaid military men and woman as sitting ducks.

To date we have lost 564 of our soldiers in Iraq, all while the real war or terrorism is left incomplete. The recent brutal attacks in Madrid have proven this to be true. Today we all unify behind the Spaniards in their fight for peace in their country and the world. My advice for the leaders of Spain: Unify to fight those that pose you the greatest imminent threat and you will be supported. If you use this time to settle old scores you will do it alone.

Darrin H. Silvester
Civics teacher
Plymouth

SHARE YOUR OPINIONS

We welcome your letters to the editor. Please include your name, address and phone number for verification. We ask that your letters be 400 words or less. We may edit for clarity, space and content.

Mail
Letters to the editor
Plymouth Observer
794 South Main
Plymouth, MI 48170

Fax
(734) 459-4224

E-mail
bkadrich@oe.homecomm.net

PLYMOUTH Observer

Part of HomeTown Communications Network™

Brad Kadrich
Community Editor

Peter Neill
General Manager

Hugh Gallagher
Managing Editor

Dick Aginian
President

Susan Rosiek
Executive Editor

Phil Power
Chairman of the Board

Jack Lessenberry
VP Editorial

Our fundamental purposes are to enhance the lives of our readers, nurture the hometowns we serve and contribute to the business success of our customers.

"They asked me about the community and what makes it special, and what we thought we had to offer that differentiates us from other communities. I talked about the new development going on, the various restaurants in town, and about Kellogg Park, all of which ... makes us a destination place."

— Plymouth Mayor Stella Greene, on promotions that will run during CNN Headline News

Reshaping workforce is vitally important

Job training is vitally important, but has got to be one of the more boring subjects around. I should know, since I've put more than my share of audiences to sleep while serving as chair of the Michigan Job Training Coordinating Council back in the 1980s. At the end of the day, however, job training turns out to be one of those things — like eating spinach, flossing your teeth, avoiding fatty foods — that might be tedious, but turns out to be an essential part of a healthy lifestyle.



Phil Power

For the economy of any state, an effective job training system — or, to make it sound more sexy, a cutting edge system to invest in human capital — is an essential part of any economic growth strategy.

Consider the facts we face in Michigan. We have lost more than 175,000 manufacturing jobs over the past four years, and our economy is still shedding jobs in the midst of what's being called a national "jobless" economic recovery. Both blue- and white-collar jobs are being outsourced to other countries, and Michigan firms are suddenly finding themselves competing around the globe with companies that pay their workers \$10-\$20 less per hour than they do.

Moreover, Michigan is gaining population much more slowly than most other states, which is why we have lost four congressional seats since 1980. Worse, we are losing precisely the kinds of people we need to be competitive in the future: young, highly skilled, college-educated.

Fewer Michigan citizens now earn degrees beyond high school than the national average, and too many of those that do move away from Michigan after graduation, supposedly drawn by "cool" cities and "vibrant" lifestyles — one key aspect of which has to be the opportunity for a good job.

And the various impacts of the state's long-running budget crisis are beginning to add up. Funding levels for K-12 schools have been essentially flat for three years, and anecdotal evidence — as well as stories ably reported in these papers in recent weeks — suggests the impact of Proposal A on those few first-class school systems has been disastrous. State support for public universities has fallen by 15 percent over the past two years.

All this spells trouble for a state now reeling from an unprecedented challenge in which it is necessary to shift from our traditional base in mass manufacturing to one focusing on flexible manufacturing and the service sector. These are things Michigan must do in order to prosper in a very competitive globalizing economy.

One part of the solution is obvious. A wholesale change in the way we think about workforce skills. More than strong backs, our workers need quick minds. Instead of dutifully turning up on time to take their bor-

ing place on the repetitive assembly line, our workers need to be innovative and adaptable. Instead of accepting their fate when laid off for lack of skills, our workers need to seize the opportunity of lifelong learning to master new skills to get new and better jobs. Instead of being juggernauts of mass manufacturing, our firms need to be more entrepreneurial, agile, questing.

Getting there won't be easy. But it's imperative. Which is why the Granholm administration, driven by David Hollister, has spent nearly two years working on an integrated plan to reshape Michigan's workforce. A report now being quietly circulated by the Department of Labor and Economic Growth starts: "No issue is more central to Michigan's economic vitality than the strength and innovation of our workforce."

"Consequently, strategic workforce investment must be at the heart of our economic development strategy. In a world economy — where information, people and jobs can move literally anywhere — our prosperity will be determined by our ability to enhance the unique assets that give our state an economic advantage."

The core idea, elegant in power and simplicity, is to directly connect economic development with workforce development. Hence the newly named Department of Labor and Economic Growth. In past years, the structure of state government confined various activities to separate, unconnected silos of bureaucratic jurisdiction: unemployment compensation, post-secondary school training, labor market information and various federal programs such as the Workforce Investment Act. Never have these components of state workforce policy ever been linked with the gritty realities of economic development.

Now, the specific charge of the Department of Labor and Economic Growth is "to align policy, management and resources in support of an integrated economic and workforce development action plan."

There are lots of very useful ideas scattered through the report. Hollister wants to radically improve the workings of the state workforce board, to define clear and measurable outcomes for both workforce and economic development. He would link the economic development functions of the Michigan Economic Development Corp. with state workforce policies and research, and do other such sensible things.

None of this is likely to make hearts beat faster immediately. But taken together, the attempt to reshape Michigan's workforce is a fundamentally important initiative. If it succeeds, it will eventually pay enormous dividends in helping our workers and our firms succeed in an environment of very tough global competition. The alternative is something we don't want to think about.

Phil Power is vice chair of the Michigan Economic Development Corp. and chairman of the board of the company that owns this newspaper. He would be pleased to get your reactions to this column either at (734) 953-2047 or at ppower@homecomm.net.

Column errs in 'Sunday School' liberal portrayal of Jesus

Jon Hubred-Golden's March 4 column reflects a common error with regard to Jesus — that He was "such a loving and gentle soul," the "Now I lay me down to sleep" gentle and mild Jesus, with soft hair, dewy eyes, at home with little lambs and doilies.

It's the Sunday School image of Jesus, the image of early 20th century polite liberalism, but hardly the New Testament image.

In the first sermon to His hometown synagogue, Jesus put it to them in such a striking way that they tried to kill Him, right then and there.



Rev. Thomas P. Eggebeen

At any number of points, the power-brokers of Judea and Jerusalem were infuriated by His preaching. He violated the Sabbath laws, he disregarded dietary regulations, he contravened custom by accepting a woman as one of his students ("Mary sat at His feet"), and He scandalized the community with His easy relationships with sinners and prostitutes.

He accused His own disciples of being shallow and faithless. He called the Pharisees white-washed tombs. He predicted the destruction of the temple and overturned the tables of a multi-million shekel exchange business.

Removed as we are from the context, it's difficult for us to understand just how offensive, irritating and dangerous He was, but that's why they finally decided to kill Him.

Throughout the gospels, Jesus makes it clear that He goes to Jerusalem for one purpose, to suffer and to die there. It's a bloody business for God to undo the ravages of sin. The Hebrews drained the blood of millions of animals over the centuries, and God said, "There's life in that blood" and by that blood, your sins are forgiven. At the heart of the Israelite faith is death — the bloody death of a goat, a bull, a sheep, a dove — that exchange of innocent life for our guilt.

With the loss of the temple in C.E. 70, a huge shift occurred in the Hebrew faith, but there is no Judaism, even today, without the memory of the temple — hence the enormous devotion displayed at the Western Wall, all that's left of the Second Temple.

Jesus taught the realities of God's purpose and what it means to love God with all of our heart, and to love our neighbor as we love ourselves. There is nothing either gentle or mild in any of it. When folks heard it, they were likely to scoff at His teachings, and when He persisted, they began to lay the groundwork for His death. To His disciples, He said, "Don't be surprised when the world hates you, remember, it hated me first."

In collusion with Rome, the power-brokers of Judea arranged His arrest and execution, and they did it in very public way, so that all the world could see what happens to anyone who would threaten either the temple industry and/or its protectorate, the Empire.

Indeed, if Jesus would have been only "a loving and gentle soul," there would have been no need for His execution. They would have embraced "the light of his life."

Has the Roman Catholic Church overplayed the gore of His death? Perhaps.

But has Protestantism underplayed it with its sanitized crosses and jolly preachers?

Is American culture obsessed with happiness and delight? Are we all the more likely to avert our eyes from suffering and avoid dark realities? We love our Disney World world, and that's where we try so hard to live — sunshine and plastic.

The Jesus of Mel Gibson's movie, though perhaps overplayed, saves us from the spiritual shallowness of our age and our fixation on truth-lite. But more than the movie, the gospels show us a robust and determined carpenter with rough hands, a biting humor, a tenderness for the weak and the fallen, and a scathing sarcasm for the proud and the puffed up.

For those who wanted ease and comfort in their faith, He said, "To follow me, you will have to deny yourselves and take up your own cross." To those seeking an easy way out, He said, "Let the dead bury the dead."

No wonder they killed Him. And no wonder that we'd rather not go there.

The suffering of Jesus gives us a context of courage and even peace to face squarely the suffering of others, and to face it someday for ourselves, too, and to do so with faith and trust — "Yea, though I walk through the Valley of the Shadow of Death, I will fear no evil, for thou art with me!"

Thomas P. Eggebeen is pastor of St. Paul's Presbyterian Church on Five Mile in Livonia.

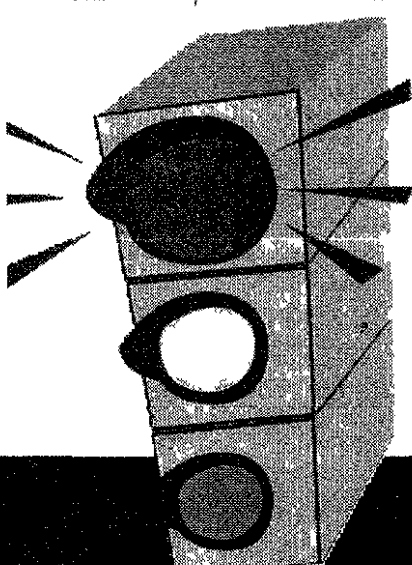

STOP

FOR SAVINGS at

CRESTWOOD

D O D G E

Vehicles

for just

\$29

BANK REPOSSESSED CARS TO BE SOLD DIRECTLY TO THE PUBLIC!!!

GARDEN CITY, MICHIGAN — Bank repossessed cars & trucks are among the most hunted-for bargains in the automotive industry. Unfortunately for John Q. Public they're also the hardest to come by.

Banks often unload these repos to car dealers at rock bottom prices allowing dealers to resell them for retail value. But bargain hunters can take heart. This week **AUTO LIQUIDATORS OF NORTH AMERICA has selected Crestwood Dodge of Garden City, Michigan to be the official liquidation site for 228 of these incredible bargains.**

This Monday, March 22nd – 9-9 pm
Tuesday, March 23rd – 9-7 pm
Wednesday, March 24th – 9-7 pm
Thursday, March 25th – 9-9 pm
Friday, March 26th – 9-6 pm
Saturday, March 27th – 10-4 pm

Crestwood Dodge will have 228 bank repos, lease returns, and other used vehicles for thousands below normal values and pass those savings on to their customers. "These have been acquired at incredible savings from banks (repos), Factory auctions and other sources," Kenny Hall (Used Car Sales Manager at Crestwood Dodge) said. "Our Creditors have asked us to sacrifice this inventory immediately — regardless of loss of profit. If that means selling these vehicles for near or below wholesale than that is what we will do."

Every bank repo and other pre-owned vehicle will be available for just \$29 plus a fee* and then start making payments. "It's that simple," said Kenny. "To make these bargains even easier we'll mark the payment right on the windshield. Just pick a car and pick a payment. You won't find a faster easier way to get a great deal on a pre-owned vehicle."

Almost every type and price range or vehicle will be available, from luxury to 4x4's to basic transportation. "With pre-owned vehicles near an all time high, chances are we will have what you are looking for in stock and ready to drive home," Kenny said. We have flown in extra sales and financial staff from three states to ensure prompt, courteous, service and the best finance terms possible. Kenny said, "We will have over \$5 million in financing available for this event, so chances are we can arrange financing for just about everyone who is employed, regardless of past history."

All trade-ins will be accepted with a minimum \$2,500 guarantee value and customers are encouraged to bring in their titles or payment book to expedite immediate delivery of these vehicles.

The opportunity bargain hunters have been waiting for is here, at Crestwood Dodge, Mon. March 22nd – Saturday, March 27th. Every bank repo and other used vehicle is just \$29 and then start making the payments. Customers won't find a faster easier way to save big money on a great used vehicle," Kenny said.

After the Mega-Sale ends Saturday, March 27th at 4 pm we will send many of these vehicles to auction. Any questions can be directed to (734) 421-5700. Crestwood Dodge is located at 32850 Ford Road in Garden City and again the dates and times for this event are as follows:

Monday, March 22nd – 9-9 pm
Tuesday, March 23rd – 9-7 pm
Wednesday, March 24th – 9-7 pm
Thursday, March 25th – 9-9 pm
Friday, March 26th – 9-6 pm
Saturday, March 27th – 10-4 pm

"We hope to see everyone there and ready to walk away with the deal of a lifetime," said Kenny.



Service Hours:
Mon.-Fri.
7 am-6 pm

CRESTWOOD

D O D G E

32850 FORD ROAD
GARDEN CITY
(734) 421-5700
TOLL FREE 1-888-MY-DODGE
(693-6343)
Open Mon. & Thurs. 9-9
Tues., Wed., Fri. 9-6

JIM

FROM PAGE A1

come from," said Courtney
Courtney moved with his family from a small town near Toronto to Detroit when he was 10. School wasn't Courtney's passion, and he quit Cooley High School twice.
"The third time I had to beg to get back in, and they made me go to summer school to prove I really would study," he said. "I really hated that I made the honor roll in the 11th grade just to show them."

MOVING AROUND

After graduation, and not knowing what he wanted to do, Courtney had "umpteenth zillion jobs. I just tried all sorts of things."
So, when he was tired of working in the power tool department at Montgomery Ward, selling cars, driving a dirt hauler and flipping burgers, Courtney said he got some advice from his dad.
"He said, 'You like to work with people, why don't you try real estate?'" said Courtney. "I asked him what real estate was."
At 22, Courtney interviewed and was hired as a real estate agent by a broker who decided to give him a chance.
"I started to walk out of the office and he asked me what kind of car I had," remembered Courtney. "I told him I didn't have one, and he asked me how was I going to sell real estate. I said, 'You said you'd train me.'"
Courtney took the bus to work every day, borrowed a car to show his listings, and became one of the company's top agents in less than 18 months. The owner helped finance a car for Courtney, who then became manager of the Livonia office and in 1970 bought 10 percent of the business.
Four years later, Courtney and his partners bought the rights to Century 21 in Michigan, and he became the marketing director, buying and

selling franchises.
"By this time, my partner Jim Preston and I were like a maintenance organization for Century 21, just sit here and collect fees with nowhere to go," said Courtney. "It wasn't exciting enough for me, so I suggested starting our own company. I came up with the name Remerica one morning at the Big Boy in 1983. We sold our Century 21 offices and opened Remerica with four agents a year later."

PROVING SKEPTICS WRONG

When Courtney told his agents they would franchise Remerica, he received some raised eyebrows. Remerica - with Courtney, Jim Preston and Marilyn Henry as partners for 24 years - now has 40 offices, and is branching out to other states.
"Jim's a very astute business person, and I like his work ethic," said Preston. "If you can't trust your business partner, then it doesn't work out. He's above board and fair, and that's why he's been very successful."
Courtney said now the fun for him now is helping others become successful. In fact, Courtney's sons, Chris and Tim, are brokers who own offices of their own in Plymouth and South Lyon.
Courtney has used his success in real estate to venture into other undertakings.
"Real estate is my foundation, but I like to take shots with other things," he said. "I'm not a money lover. I want to use it."
In the early 1970s, Courtney performed with the Plymouth Theatre Guild, starring in several plays. He got his Screen Actors Guild card and did a few commercials, and eventually did some stand-up comedy.
Courtney performed for Mark Ridley, owner of the Comedy Castle in Royal Oak.
"I went under the name Jimmy C," said Courtney. "Mark said people would call and ask when I would be performing."
There wasn't much money in



Jim Courtney of Plymouth Township is a top real estate agent and broker, a stand-up comedian, an executive producer of several movies and a world-class poker player.

stand-up unless you traveled, but Courtney wasn't willing to go on the road and leave his children behind.
However, he did stay in touch with Ridley.
"Mark didn't have a place of his own at the time, so I put up some seed money to help him get investors," said Courtney. "I've been a partner with him

for 19 years, and the Comedy Castle was voted by *USA Today* as the sixth-best comedy club in the country."
Ridley said Courtney was a decent comic, but a better friend and business partner.
"Jim wasn't a bad comic," said Ridley. "He's the kind of guy that once he sets his sights on something, he's determined to make it successful. Comedy wasn't going to be a full-time profession, more of a hobby."
"However, he's the perfect silent partner," admits Ridley with a laugh. "I've known him for 25 years, and he's always open to new ideas, and very analytical, which makes him a good businessman. I'm never afraid to approach him with an idea, and if he says it's not going to work, it probably won't."
Ridley helped book comedy acts for the Penn Theatre, before Courtney and his part-

ners sold it just last week.
"I'm a little upset because I believe we had the finest piece of real estate in downtown Plymouth," said Courtney of the sale. "But, I can't fault my partners for wanting to sell."
POKER TRIP
Next month, Courtney will again participate in the World Series of Poker in Las Vegas, which he's done every year but two since 1984. His best-ever finish was third, when he won \$125,000. Last year, he finished 14th, winning \$9,300.
"When we moved to Detroit I had a broken leg. I wanted to fit in with the other kids, but since I couldn't play sports, we started playing nickel-and-dime poker," he said. "I don't consider myself a gambler, I'm a poker player. I don't play craps or the slots, that's really gambling."
He's currently pitching a

syndicated television game show based on poker.
Courtney has also had his hand in producing a number of movies, including *Time Quest*, which was shot in Detroit and is showing in Europe, as well as on video in the U.S.
"It details what would have happened if President John F. Kennedy had lived," he said.
But, despite all the successful ventures, Courtney said it's his family life that keeps him happy.
He and his wife, Linda, have their four children - Chris, Tim, Melissa and Kelly, along with the six grandchildren - get together often.
"We all get together for dinner on most Sundays," he said. "The family is a big priority. I like to keep the family very tight, very close."
tbruscato@oe.homecomm.net
(734) 459-2700

Spring Into Safe Backyard Play!
With Great Pre-Season Pricing!
ChildLife
★ Highest Quality & Safety
★ Low Maintenance
★ Lifetime Warranties
★ Kid Friendly Materials (No C.A. or A.C.Q. Treatment)
★ Modular Design
Shop and Compare... We're Your Best Value!
The Doll Hospital & Toy Soldier Shop
3947 W. 12 Mile • Berkley • 248-543-3115 • M-W, Fr & Sa 10-5:30 • Thu 10-8:30

UNCLE BOB'S TRADE CENTER
IN WESTLAND • OPENING IN MAY!
Collectibles, Crafts, Antiques, New Merchandise
250 DEALERS WANTED!
"FREE RENT TO FIRST 50 DEALERS"
RESERVE YOUR SPACE NOW!
Open Every Weekend
Fri. - 4 pm to 9 pm
Sat. - Sun. 10 am to 8 pm
Call 248-433-5566
Free TV Coverage Every Weekend

LET PLANTING BEGIN!
Summer Blooming
BULBS AND PERENNIALS
You'll find a HUGE selection of packaged summer blooming bulbs and perennials, including: gladioli, canna, dahila, begonia, calla lily, caladium, bleeding heart, oriental lily, daylily, peony and more!
BRADFORD PEAR \$99.00
ROSES from \$9.99
PANSY 99¢
PLYMOUTH NURSERY and GARDEN CENTER
734-453-5500
The way to grow!
www.plymouthnursery.net
EARLY SPRING HOURS:
Mon-Sat 9-6 • Sun 11-5
OFFERS EXPIRE 3/31/04
9900 Ann Arbor Rd./Plymouth Rd.
7 Miles West of I-275
1 1/2 Miles South of M-14
Corner of Gotfredson Rd.

FLEXBUY

THE NEXT GENERATION OF NEW CAR FINANCING
Low up-front costs. More time to pay. With Flexbuy, you can get more than you might expect. See dealer for details.

NO MILEAGE RESTRICTIONS
Ford Credit will apply your Flexbuy \$1,800 rebate toward the first 36 months of your 66 month purchase contract to reduce your monthly payment, which leaves extra money in your pocket

ELIGIBLE A/Z/D PLAN EMPLOYEES AND FAMILY MEMBERS

FLEXBUY ⁽¹⁾		STANDARD FINANCING	
24-Month Payments	36-Month Payments	36-Month Lease	60-Month Payment
\$195	\$245	\$207	\$263

(1) 2004 Taurus SE MSRP \$20,890. 66 months with \$1,000 down excluding taxes, title and license fees at 0.9% APR. \$195 payment calculated when Flexbuy of \$1,800 is applied to first 36 months. Renewal cash of \$1,000 included. For Flexbuy take new retail delivery from dealer stock by 03/31/04. Residency restrictions apply. See dealer for qualifications and complete details. (2) 36 months with \$1,000 down excluding taxes, title and license fees. Includes security deposit and acquisition fee. Some payments higher some lower. (3) 60 months with \$1,000 down excluding taxes, title and license fees at 0% APR. Not all buyers will qualify for Ford Credit Financing. All payments include \$1,000 Ford Credit bonus cash.

SUBURBAN FORD DEALERS
OPEN 3647 HOURS

Varsity
3480 Jackson Rd. 1-800-875-FORD
ANN ARBOR

Atchinson
9800 Belleville Rd. 734-697-9161
BELLEVILLE

Briarwood
7070 Michigan Ave. 734-429-5478
SALINE

Gene Butman
2105 Washtenaw 734-482-8581
YPSILANTI

Hines Park
1-96 at Milford Rd. 248-437-6700
LYON TWP.

Friendly
2800 N. Telegraph. 734-243-6000
MONROE

Sidelines

Top pitcher

Shannon Noder, a freshman on Madonna University's softball team, earned Wolverine-Hoosier Athletic Conference pitcher of the week honors for her performance last weekend at the Bethel (Ind.) College Tournament. Noder started two of the Crusaders four games over the weekend, earning one win and getting a no-decision. Her win was a 16-0, five-inning mercy of St. Francis (Ind.), in which she allowed four hits and one walk. Her no-decision was even more impressive: eight innings in a game against Indiana Wesleyan that was called by darkness with the score tied at 1-1. Noder allowed one run on two hits and three walks, striking out 10.

For the season, she has a 4-2 record, allowing 14 earned runs on 41 hits and 24 walks in 531 innings with 34 strike outs and a 2.36 earned run average.

Registration

The Canton Community Junior Baseball/Softball Association will have registration from 9 a.m. to 3 p.m. Saturday, March 27, in the Chestnut Room of the Summit on the Park, located at 46000 Summit Parkway in Canton.

Registration is open to boys and girls 4-18 years old who are residents of Canton or Plymouth, or who live in the PCCS school district. All registrants must show proof of residency and age at time of registration.

Fees range from \$75-\$110 for recreation leagues, travel teams' rates are higher.

For more information, call (734) 394-5489.

Baseball clinic

The annual Salem Baseball Clinic will be in two sessions, the first on Saturday, March 27, and the second on Saturday, April 3, both in the Salem HS gym.

Three hours of baseball instruction from the Salem varsity players and coaches, for players ages 7-15, is included. Lunch is provided as well, registration fee is \$20.

To reserve a spot or for more information, call Ron Myers at (734) 459-4026.

Walking club

The city of Plymouth Recreation Department will offer a new Walking Club beginning March 29. Every day, on a drop-in basis, people will meet at the Plymouth Cultural Center (located at 525 Farmer) and walk a variety of routes mapped out by the Recreation Department, or they can blaze their own trail.

There are no fees or registrations involved. The morning start time is 9:30 a.m., the evening start time is 6:30 p.m.

For more information, call the city of Plymouth Recreation Department at (734) 455-6620, Ext. 302.

Whalers blank Rangers, open up 3-1 lead

The total had been steadily climbing two, then three, and on Monday it reached five.

The Plymouth Whalers survived the first two games with backup goalie Ryan Nie in the net for the injured Paul Drew, largely due to Nie's performance. But when you're playing a team like the Kitchener Rangers, the defending Ontario Hockey League champions and one of this season's top offensive teams, one can only wonder if it will collapse.

Did Monday's 5-4 loss in Kitchener herald the end for the Whalers? Were the Rangers goal totals going to continue to climb, together with Plymouth's number of losses?

Wednesday's game at Plymouth's Compuware Arena, the fourth in the series, would go a long way toward answering that query.

Nie stopped all 28 shots Kitchener unleashed at him, collecting his first shutout of the season and giving the Whalers a three-games-to-one lead by backstopping a 2-0 victory.

Game Five will be at 7:30 p.m. Friday in Kitchener. If a Game Six is necessary, it will be at 2 p.m. Sunday at Compuware Arena.

"Plymouth was the better team tonight," said Rangers' coach Pete DeBoer. "They came at us with better speed. Our goalie (Brad Topping) kept us in it, we hung around, but we didn't get enough scoring opportunities."

Which pleased Whaler coach Mike Vellucci. The challenge was great enough going into this opening-round playoff against a team like Kitchener, but losing Drew to an ankle injury for what likely could be the rest of the season made it all the more difficult. Nie had hardly played in the last month of the season, he would need support from his teammates.

On Wednesday he got it, particularly from the Whalers' special teams. They converted 2-of-4 power-play chances, and that's all they would need, since their penalty-kill units were equally effective, completely shutting down the Rangers and allowing just four shots on goal on four power plays.

"Our special teams were the difference," Vellucci said. "We had a ton of chances, but their goalie was playing really well."

Not quite well enough, however. With Kitchener's Peter Franchin off for holding seven minutes into the first period, the Whalers started teeing off on Topping — in particular defenseman James Wisniewski, who quarterbacked Plymouth's power-play unit.

Wisniewski unleashed a couple of hard shots from the blue line that Topping turned away, but a shot by Tim Sestito from between the circles dribbled through his pads and into the net for a 1-0 Whaler lead. Vaclav Meidl and Jonas Fiedler assisted.

It remained that way until late in the second period. With 4:06 left, the Rangers' Boris Valabik was sent off

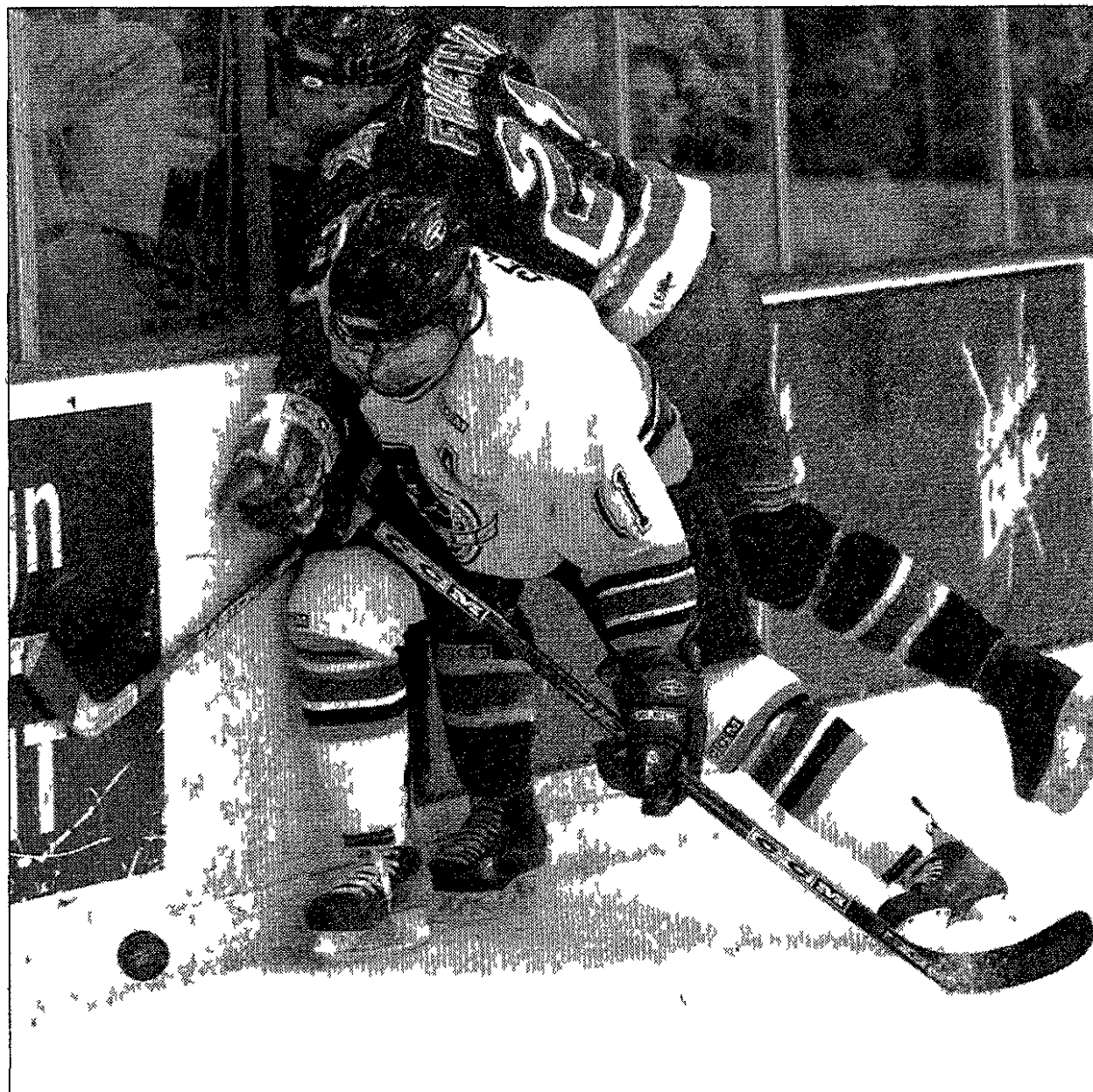

Plymouth's Tim Sestito (11) battles Kitchener's Peter Franchin along the boards for possession of the puck. Sestito scored the Whalers' first goal of Wednesday's game.

for roughing. With 20 left in the Whalers' power play, John Mitchell took a pass in the right circle and flipped a shot over the sprawling Topping, increasing Plymouth's lead to 2-0. Mike Letizia and John Vigilante assisted.

That would be all Nie would need. The Whalers ended up with a commanding 39-28 advantage in shots on goal.

As satisfying as the win was, Vellucci wasn't ready to start thinking about the next round of the playoffs. "We need another win," he said.

And he knows his special teams will have to carry a heavy load. "No matter what round we go through, they'll have to play well," he said. "We don't score a lot of even-strength goals. We rely on our power play." It's been working well so far.

Chiefs still figure to be powerful

One could say this isn't a typical Canton girls soccer team. That isn't to say the Chiefs won't be challenging for the Western Lakes Activities Association championship once again — they will.

The difference is in the numbers. Don Smith will have just 20 players on his roster, the fewest number he's had since his first season as coach, some 18 years ago.

Although about a half-dozen players short of his normal roster size, Canton still figures to be a force in both the conference and the state. How much of a force won't take long to determine. The Chiefs open the season with a slew of state powers, starting with Novi on Monday (at Canton), followed by Birmingham Seaholm, Troy, Grosse Pointe North, Ann Arbor Pioneer and, after a match against Walled Lake Central, an away game at Troy Athens.

Any coach would be thankful to break even against a slate like that. Canton, which lost to Salem in the WLAA championship but won its state district title (beating the Rocks in the semifinal) and posted a 15-4-2 record, could do better than that.

"We start out very tough," said Smith. "We'll either be feeling good about ourselves or licking our wounds."

There are some notable losses, to be sure. Gone are top scorer Erica Ahrens (16 goals, 12 assists), all-conference keeper Briana Wolcott, attacking midfielder Kara Marsh and defensive midfielder Danielle Shepard.

Replacing them won't be easy, but as Smith noted, "Well, we're going to try. Someone always steps up."

"We're going to be a pretty good squad. We have some playing experience at midfield."

Smith will be moving some key players around to bolster his team,

PLEASE SEE CHIEFS, B5

Standouts could carry Salem a long ways

Any girls soccer coach in the state would like to have the problems Joe Nora faces as Salem's coach.

Simply because there aren't too many. The Rocks did something last season they hadn't done since 1987. They won a Western Lakes Activities Association championship, beating Canton in the title match.

Now they want to do something they haven't managed to accomplish since Nora, entering his fifth season, has been coach. win a state district title and, hopefully, go much further than that in the tournament.

It won't be easy, for sure, but the Rocks have the ingredients to make a run at the state crown. Of course, they were in a similar position last season, when they went 14-2-2, losing twice to Canton —

the second time in the districts.

That's because Marissa Sarkesian and Jordan Falcusan were roaming the midfield as juniors. Both were, and still are, considered two of the state's best players, indeed, Falcusan was named the state's top player last year, with Falcusan one of the finalists.

A playmaker, Sarkesian had 17 goals and 17 assists as a junior. Falcusan finished with 11 goals and six assists.

"There's not too much they can't do," said Nora. "They can pretty much play anywhere on the field. They are awesomely well-rounded players."

But now, as senior captains (they were co-captains last season as juniors), can they propel the Rocks to the next level?

"That's the big question going into the year," Nora said. "I've already seen

improvement in their game, not only their playing together but their ability to link up with their teammates is better already."

That alone should make Salem very dangerous, but Nora is quick to point out that "we're not a two-player team. What we have going for us is our depth."

Six players were lost from last season's squad: keeper Heather Jones, midfielders Janae Bucks, Nicole Gemrich and Macy Lepper, stopper Lindsay Stiver and defender Janelle Miller.

But there are still 14 returning players, which includes Sarkesian and Falcusan, all of whom have considerable experience.

Like senior keeper Kristen O'Beirne,

PLEASE SEE SALEM, B5

Stevenson wins league, coach gets title

It had to happen. And Livonia Stevenson boys swim coach Jeff Shoemaker was ecstatic that his team was the one to manage it.

The 'it', of course, was wresting the Western Lakes Activities Association championship away from Salem HS,



Shoemaker

which had dominated the league for the previous 11 years. A combination of events, including a determined effort by the Spartans,

allowed them to accomplish their objective. Winning the WLAA title, combined with an undefeated record in conference dual meets and a first-place finish in the WLAA Relays, led to Shoemaker being proclaimed the Observer boys swim coach of the year.

Typically, he wasn't willing to take too much credit for what the Spartans did this season. The third high school



Matt Jurcak swam on three relays and in the 100-yard backstroke at the state meet for Salem, good reasons for his selection to the all-Observer team (story on B2).

opening in the Plymouth-Canton district cost Salem several top swimmers, as Shoemaker put it, the "distribution of athletes just caught up with them."

The same terminology could be applied to Stevenson, a team that started with a sturdy foundation and was built into a conference cham-

pion through hard work and some notable roster additions.

"This is the best team I've coached at Stevenson," said Shoemaker, who just completed his fourth season as head coach. He was an assistant coach for five years prior to that.

"Our veteran swimmers did a lot of off-season training," he replied when asked what took

this team to the title. "We had a great freshmen class, too. And we got a couple of transfers, (senior) Steve Helewski from Walled Lake Western and (junior) Andrew Schoff from Livonia Churchill."

"They definitely helped us. They made the (conference) win a little more cushioned."

And have no doubts: winning the WLAA was the Spartans top priority.

"Our main concern was winning the league meet this year," said Shoemaker. "Now that we've accomplished that, we'll be looking at the state meet next year."

Of course, the WLAA championship will remain on Stevenson's agenda, too. And as Shoemaker, the Observer's coach of the year for the second-straight season, was well aware, winning the league crown will remain high on his adversaries' lists, too.

Only now Stevenson, not Salem, will be the targeted team — a distinction proudly earned.

See All Area boys swimming on page B2

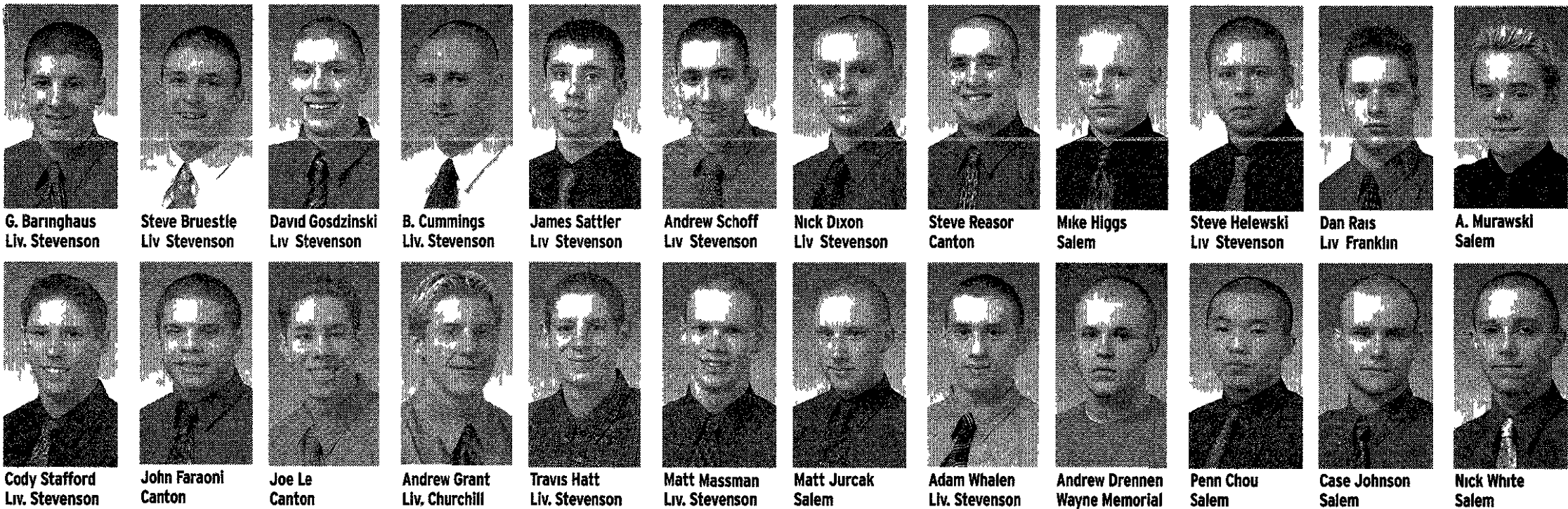

FIRST TEAM

James Sattler 200-yard freestyle Canton What Sattler wanted to do his senior season at Canton was make an impact and he did. He qualified for the state finals in the 200 freestyle, bettered his best time at the state meet and finished better than he was seeded.

Sattler placed fourth in the 200 free and was sixth in the 500 free at the Western Lakes Activities Association meet and he was part of two state qualifying relays.

James has been our main distance swimmer for the past two years, said Canton coach Ed Weber. His off-season training made a positive impact on his season and will help motivate other team athletes to do the same.

Nick Dixon 200 individual medley Salem Perhaps the most accomplished swimmer in the Observerland area, Dixon finished first in the 200 individual medley and was fourth in the 500 free at the WLAAs. Then placed fourth in the 200 IM (1:56.99) and seventh in the 100 backstroke in 53.67 at the state finals. His performance at state earned him All-American consideration in both events.

He was also on two relay teams that scored at state. And the best part as far as Salem is concerned is that Dixon is just a junior.

Nick is an outstanding swimmer as well as a person, said Salem coach Chuck Olson. He trains as hard as he competes and provides leadership in every phase of the student-athlete.

Mike Higgs 50 freestyle Salem Higgs a junior rebounded from a mediocre performance at the WLAAs in both the 50 and 100 free. He placed 13th in both, although his time in the finals of the 50 (23.35) was the sixth fastest. To post the second best time in Observerland in the 50 when it counted, leading off the 200 free relay in 22.88.

Higgs was part of all three relays that scored points for the Rocks at the state meet.

Mike made a big difference in his first conference meet and state meet competition, said Olson. He gained a lot of experience as a junior that should lead to a great senior year.

Dan Rais diving Livonia Franklin The sen-

ior finished ninth in the Division I state meet improving one place over last season. He also won the WLAAs and regional meets with 11 dive totals of 38.70 and 36.45 respectively.

He is Franklin's school record holder for six dives (261.50) and is a team record holder for six dives (265.80).

Rais is a four-year letter winner and four-year state qualifier. He finished undefeated this season in dual meets.

The Franklin scholar athlete is also an accomplished Level 1 gymnast.

Steve Bruestle 100 butterfly Livonia Stevenson The sophomore posted a season best 53.85 at the Division I state meet, 18th best time in the prelims. He was also runner-up in the WLAAs meet with a time of 54.36.

Steve had amazing improvement over his freshman year. Stevenson coach Jeff Shoemaker said, "I look for him to score big points at the state meet next year. What makes him go is his personal motivation with a desire to win."

Joe Le 100 freestyle Canton This senior headed for Eastern Michigan made his final season with the Chiefs an exceptional one. He won both the 50 and 100 freestyle at the WLAAs. He qualified for state in both, then placed fifth in the 100 free at state (48.05), he went 47.99 in the prelims after narrowly missing qualifying in the 50 (he was 17th in 22.10, out of the top 16).

Le's been all state in the 100 free the past two years, was part of the school record setting 400 free relay and was on the 200 free relay that set the pool record at Livonia Churchill.

Joe has come into each season with a goal in mind, said Weber. No matter how big a goal, Joe has focused his season around accomplishing it.

Travis Hatt 500 freestyle Stevenson The freshman won the Western Lakes meet with a time of 4:48.51 and had the 18th best clocking in the Division I state meet prelims (4:55.29).

He was a state qualifier in three different events and was runner-up in the WLAAs meet in the 200 IM (2:01.29).

Travis can swim anything, Shoemaker said. He's the best freshman I've seen come through the program in a long time. He will be very valuable for the next three years. I am looking forward to seeing how fast

2003-04 ALL-AREA SWIMMING TEAM

200-yard freestyle 1 James Sattler Sr. Canton 2 Andrew Schoff Jr. Livonia Stevenson

200 individual medley 1 Nick Dixon Jr. Salem Steve Reasor Sr. Canton

50 freestyle 1 Mike Higgs Jr. Salem 2 Steve Helewski Sr. Stevenson

Diving 1 Dan Rais Sr. Livonia Franklin 2 (tie) Cody Andrew Murawski Jr. Salem Cody Stafford Jr. Livonia Stevenson

100 butterfly 1 Steve Bruestle Soph. Stevenson 2 John Faraoni Jr. Canton

100 freestyle 1 Joe Le Sr. Canton 2 Andy Grant Sr. Livonia Churchill

500 freestyle 1 Travis Hatt Fr. Livonia Stevenson 2 Garrett Baringhaus Jr. Livonia Stevenson

100 backstroke 1 Matt Jurcak Jr. Salem 2 Adam Whalen Jr. Stevenson

100 breaststroke 1 Andrew Drennen Sr. Wayne Memorial 2 David Gosdzinski Soph. Livonia Stevenson

Travis actually gets in the years to come. **Matt Jurcak 100 backstroke Salem** Jurcak a junior was exceptional in both the 200 free and 100 backstroke, earning all conference honors in both. He was third in both the 200 free (1:50.01, 1:49.95 in the prelims) and the 100 back (57.02) at the WLAAs meet and was part of all three scoring relays.

Matt had a great junior year in which he continued to improve in every phase of his training and competing, said Olson. He has the ability to be a competitive force in the state as a senior.

Andrew Drennen 100 breaststroke Wayne The four-year letter winner and two-year team captain capped a strong senior year by finishing 15th in the Division I state meet with a time of 1:02.22, second fastest in school history.

The two-time Wayne MVP also finished third in the WLAAs meet with a time of 1:03.63.

He is a three-time Wayne Invitational champion in the 100 breaststroke and is part of the Zebras school record 200 freestyle relay team. He was also a two-time Michigan Mega Conference All-Red Division selection.

RELAYS

200 medley 1 Stevenson (Garrett Baringhaus Jr. Steve Bruestle Soph. David Gosdzinski Soph. Brendan Cummings Sr.) 2 Salem (Matt Jurcak Jr. Nick Dixon Jr. Case Johnson Sr. Penn Chou Jr.)

200 freestyle 1 Stevenson (Steve Helewski Sr. Travis Hatt Fr. Matt Massman Soph. Brendan Cummings Sr.) 2 Salem (Mike Higgs Jr. Nick White Sr. Penn Chou Jr. Matt Jurcak Jr.)

400 freestyle 1 Salem (Matt Jurcak Jr. Mike Higgs Jr. Penn Chou Jr. Nick Dixon Jr.) 2 Stevenson (Andrew Schoff Jr. Garrett Baringhaus Jr. Brendan Cummings Sr. Travis Hatt Fr.)

COACH OF THE YEAR

Jeff Shoemaker Stevenson
Honorable mention Andy Knisley (Plymouth) Chris Brown (Stevenson) Adam Whalen (Stevenson) Tyler Flood (Catholic Central) Jason Anderson (Stevenson)

He has also won numerous awards in USS Swimming meets and plans to continue his swim career at Wayne State University.

All the recognition that Andrew gets is well deserved, Wayne coach Mike Greuber said. In my 12 years on the coaching staff I have not seen a more dedicated swimmer. He is in the water 11 months a year and is always striving to improve himself and helping to improve his teammates.

I know it's a cliché to say he's a coaches' dream, but he is. I am proud of the man he has become and everything he has done and the awards he has received. He has done so with humbleness. We wish him the best of luck in the future.

SECOND TEAM

Andrew Schoff 200 freestyle Stevenson The junior placed fifth at the WLAAs meet in the 200 freestyle with a time of 1:50.64, just missing a state cut. He also took a fourth in the 100 freestyle (51.08 in the prelims).

He was also a member of Stevenson's first place WLAAs 400 freestyle relay squad. Andrew has a tremendous amount of talent, Shoemaker said. With some summer

training, Andrew could score in two individual events next year at the state meet. He has excellent stroke technique and a willingness to win.

Steve Reasor 200 IM Canton A senior Reasor placed in the top 10 in both the 200 individual medley and the 100 breaststroke at the WLAAs meet. He was seventh in the 200 IM (2:08.35, the fifth fastest time) and ninth in the 100 breast (1:08.00). He also helped the 200 medley relay qualify for the state meet.

As a captain this year, Steve was a major part of our success, said Weber. He is a good leader and made a positive impact on all the team members.

Steve Helewski 50 freestyle Stevenson The senior transfer from Walled Lake Western was a state qualifier in both the 50 freestyle (22.8) and 100 butterfly (54.19).

At the Western Lakes meet, Helewski was seventh in the 50 freestyle and third in the 100 butterfly (55.32 in the prelims).

He also helped the Spartans score at the state meet in the 200 freestyle relay.

Steve has a large amount of untapped talent, Shoemaker said. He would make any college coach happy to have him swim for them.

He was a vital part of this year's league (WLAAs) championship team.

Andrew Murawski diving Salem Murawski a junior earned all conference honors, placing fourth with an 11-dive score of 323.65 points, qualified for state meet by finishing 10th at the regional qualifier with a 327.60 score, then placed 18th at state.

Andrew has been Salem's No. 1 diver the past three years, said Olson, and he's improved to the level of one of the best returning divers in the state.

Cody Stafford diving Stevenson The junior was WLAAs runner-up to Franklin's Dan Rais with an 11-dive total of 335.80.

He also qualified for the state meet by finishing 11th in the regional with a score of 318.75.

Cody has excellent agility on the board, Shoemaker said. We hope to see Cody win the league (WLAAs) next year and place at the state meet.

With some off-season training, Cody could be unstoppable.

John Faraoni 100 butterfly Canton Faraoni was a good example of why Canton

was able to finish second at the WLAAs finals. A state qualifier in the 100 butterfly, the junior placed fourth in that event (55.75) and was sixth in the 50 free (23.42) at conference. His best time in the 100 fly (55.02) came at state meet where he finished 26th.

This was his first state qualifying year, said Weber. John is a strong swimmer with lots of ability. I'm proud of how well he did this year and excited about next year.

Andrew Grant 100 freestyle Livonia Churchill The senior and four-year swimmer finished seventh in the WLAAs meet with a season best time 50.78. He also took a seventh in the 200 freestyle with a clocking of 1:52.13 (in the prelims).

Andy got sick late in the year, but for the time he spent in the water, he had a very successful year, Churchill coach Keith Niedbala said. He was a good captain and will truly be missed next year.

Garrett Baringhaus 500 freestyle Stevenson The junior was state qualifier in both the 500 freestyle (4:57.21) and 100 butterfly (54.24).

He was the WLAAs champion in the 100 butterfly (54.24) and took fifth in the 500 freestyle (5:01.324). He was also a member of two state qualifying relay teams.

Garrett was a state qualifier for the second year in a row, Shoemaker said. He has an awesome amount of talent and will swim anything. We're looking for some great things out of Garrett next year.

Adam Whalen 100 backstroke Stevenson Whalen a junior earned seventh in the 100 backstroke with a time of 59.0 and also scored in the 100 freestyle (52.74) in the Western Lakes meet with a 15th place.

His 100 backstroke clocking was the first time he broke a minute.

Adam went from scoring no points last year to scoring in both individual events this year, Shoemaker said. He was our hardest trainer in the off-season. I can't wait to see him next year.

David Gosdzinski 100 breaststroke Stevenson The sophomore made the state cut with a time of 1:03.38 after finishing runner-up in the Western Lakes meet.

David made much improvement over last year, Shoemaker said. He will score many

PLEASE SEE SWIMMING, B3

DETROIT RED WINGS Youth Hockey Camp

HAVE FUN, PLAY HOCKEY, AND SKATE WHERE THE PROS PLAY!

DETROIT RED WINGS YOUTH HOCKEY CAMP

PRESENTED BY OUTBACK STEAKHOUSE

HOSTED BY DETROIT RED WINGS ASSOCIATE COACH BARRY SMITH

TWO SESSIONS:
AUG. 7TH - AUG. 9TH AND AUG. 11TH - AUG. 13TH

SKATERS \$229 AGES 7 - 14 GOALIES ONLY \$199

FOR MORE INFORMATION OR TO REGISTER YOUR CAMPER, LOG ON TO DETROITREDWINGS.COM OR CALL 313-396-7575

Enter to win Detroit Red Wings Tickets
Check Today's Classifieds Section to See How You Can Enter to Win!

THE Observer & Eccentric NEWSPAPERS

CONGRATULATIONS Suburban Hockey — and — Observer & Eccentric TEAM of the MONTH TROY RED WINGS

Congratulations to the Troy Red Wings, Champions of Mini Mite Mania in Muskegon!

Observer & Eccentric THE MICHIGAN HOCKEY

Sign up for Suburban Hockey's Spring Clinics! Two-hour clinics will run at the Ice Box Sports Center in Brownstown on April 12, Novi Ice Arena on April 13, Onyx-Rochester Ice Arena on April 14, Lindell Arena in Royal Oak on April 15 and Suburban Training Center in Farmington Hills on April 16. Clinics include Shoot to Score, Learn to Check, Outside Edges, Defense and Quick N' Fast. Call (248) 478-1600 or visit www.suburbanhockey.com today!

BEST BOYS SWIM TIMES

Table with swimmer names, times, and events. Includes 200 YARD MEDLEY RELAY, 200 FREESTYLE, 100 BUTTERFLY, 100 FREESTYLE, 50 FREESTYLE, 200 INDIVIDUAL MEDLEY, and 400 FREESTYLE RELAY.

Table with swimmer names, times, and events. Includes 200 FREESTYLE RELAY, 100 BACKSTROKE, 100 BREASTSTROKE, and 400 FREESTYLE RELAY.

Rangers edge Whalers in Game 3, 5-4

A four-goal outburst in the second period lifted the Kitchener Rangers to a 5-4 victory over the Plymouth Whalers Monday in a first-round Ontario Hockey League game played in Kitchener. The Rangers' win enabled them to narrow Plymouth's lead in the series to two-games-to-one. Petr Kanko and Nathan O'Nabigon were the catalysts for Kitchener. Kanko scored two goals and assisted on another, while O'Nabigon collected a goal and two assists. The Whalers had the early lead, getting a goal from Tim Sestito (assisted by James Wisniewski and Brent Mahon) at 13:25 of the first period. The Rangers took command in the second period, Kanko scoring at 1:32 and Andre Benoit following with a power-play goal at 3:57. Peter Franchin followed with a score at 7:22 to make it 3-1, and O'Nabigon got a short-handed marker at 16:31 to increase Kitchener's advantage to 4-1. The Whalers did not surrender, however Mike Knight scored twice in the third period, John Mitchell assisting on both, the second coming with 3:35 left to play, narrowing the deficit to 4-3. However, the next 33 were

truly offensive. Kanko's second goal of the game, scored 19 after Knight's second goal, gave the Rangers a two-goal lead. Mike Letizia then got a goal for the Whalers with 2:02 still remaining, but they could not pull even. John Vigilante also had two assists for Plymouth, and Adam Keefe had two helpers for Kitchener. Brad Topping stopped 32 of 36 shots on goal for the Rangers. Ryan Nie had 33 saves for Plymouth. Whalers 6, Rangers 3: Plymouth looked sluggish through much of the opening period of Saturday's game against Kitchener, played at Plymouth's Compuware Arena. But goalie Ryan Nie kept them in the game until the Whalers could get on track. Which they did in the final four minutes of the period. John Vigilante tipped in a pretty pass from Mike Knight to tie it at 1-all with 3:48 left in the period, and a minute later Andrew Fournier put Plymouth ahead after a Ranger misplay in front of their own net. The Whalers never trailed again in taking a two-games-to-none lead in the best-of-seven series. James Wisniewski provided any needed insurance

with a pair of power-play goals on hard blasts just inside the blue line. Tim Sestito's goal 4:32 into the second period put Plymouth ahead 3-1, and Wisniewski followed with his first goal of the game from between the circles with just under two minutes left in the period. His second goal — and third of the playoffs — was a rocket from the blue line at 4:16 of the third, making it 5-1. However, a minute later Kitchener's Evan McGrath, whose first-period score had given the Rangers an early 1-0 lead, scored again to make it 5-2. Peter Franchin followed with a goal with 6:25 still to play, trimming the deficit to 5-3, enough of a comeback to make the Whalers nervous. Plymouth's John Mitchell put the issue to rest with his empty-net goal with 2:23 to play, Mitchell finished with a goal and two assists, while Wisniewski had two goals and an assist and Gino Pisellini had two assists. Kitchener got two goals from McGrath and two assists from Nathan O'Nabigon. Nie, filling in for injured starter Paul Drew, stopped 22 shots for the Whalers. Kitchener used both Brad Topping and Carlo DiRienzo in goal.

SWIMMING

FROM PAGE B2

points at the state meet next year. And with off season training could break the 1 minute mark. He could end up one of the fastest breaststrokers to leave Stevenson. 200 medley Stevenson (Garrett Baringhaus, Steve Bruestle, David Gosdzinski, Brendan Cummings). This quartet won the Western Lakes meet with a time of 1:40.62 and finished fifth in Division I with a time of 1:41.53. Baringhaus is a junior while Bruestle and Gosdzinski are sophomores. Cummings a senior was the captain of this year's team. Brendan was an excellent team leader this year and a vital part of all three relays. Shoemaker said "He came through for us at the end of the year. He's a real champion swimmer and will step up when asked." 200 freestyle Stevenson (Steve Helewski, Travis Hatt, Matt Massman, Brendan Cummings). This foursome placed 14th in Division I with a time of 1:30.86 after going 1:30.45 in the prelims. They also captured the

Western Lakes meet. Cummings a senior posted the fastest 50 free split on this relay. Helewski is also a senior. Hatt a freshman and Massman a sophomore. Massman just missed a state cut this year in the 50 freestyle (23.21). Matt will be a vital part of next year's team in the sprint events. Shoemaker said "One more year of growing and Matt will make his state cut." 400 freestyle Salem (Matt Jurcak, Mike Higgs, Penn Chou, Nick Dixon). After placing fourth at the WLAAs in 3:22.43 this four some peaked at state meet, trimming 2.64 seconds off their previous best time and placing 16th in 3:19.79. More good news for Salem — all four are juniors which means the Rocks should do even better in this event next season. This relay finished an outstanding state meet for Salem. Said Olson "Their continued time drops individually led to their success as a team." SECOND-TEAM RELAYS 200 medley Salem (Matt Jurcak, Nick Dixon, Case Johnson, Penn Chou). Things started to come together for this quartet at the MISCA meet when it got its state qualify

ing cut with a time of 1:43.50. At the WLAAs finals they dropped 1.52 more seconds off their time in finishing third in 1:41.98 then improved their time again at state placing 12th in 1:41.73. These four always got the team going in the first event with an outstanding effort and results said Olson "which had a major impact on Salem's 14th place finish at state meet." 200 freestyle Salem (Mike Higgs, Nick White, Penn Chou, Matt Jurcak). This team went 1:32.49 at the MISCA meet after which they placed second in the WLAAs in 1:33.67. At state they dropped 1.69 seconds off their best clocking placing 15th in 1:30.80. These four swimmers did a great job in every big meet this year. Said Olson "Their second place finish at the conference meet was only a stepping stone for their 15th place finish at state." 400 freestyle Stevenson (Andrew Schoff, Garrett Baringhaus, Brendan Cummings, Travis Hatt). The Spartans earned a trip to the Division I state meet at the University of Michigan's Canham Natatorium with a seed time of 3:20.11 which earned first place honors in the Western Lakes meet. The Spartans clocked a 3:23.18 to wind up 22nd in the state preliminaries.

TAX PROBLEMS? We settle any tax, any year. Tax Resolution Specialist (248) 985-HELP (4357)

BARNETT Roofing and Siding Inc. RESIDENTIAL • COMMERCIAL. Certanteed Select Shingle Roofer. Duro-Last Master Elite Award Winner. Professional Roofer Advisory Council. Family Taking Care of Families for Over 41 Years! 41700 Michigan Ave • Canton • 734-397-8122

Follow your favorite high school sports team each week in the Observer

CHARTER TOWNSHIP OF CANTON PUBLIC COMMENT PERIOD FY 2004 CDBG ACTION PLAN. Beginning March 18 2004 and for 30 days thereafter the Charter Township of Canton will accept public comment on the FY 2004 Community Development Block Grant Action Plan. Comment will be accepted on the following project proposals: First Step \$36,000 Growth Works, \$8,800 Wayne County Neighborhood Legal Services, \$10,100, Wayne Metropolitan Community Action Agency \$1,500 Volunteer Coordinator, \$6,500, Summit Scholarship \$1,500 Human Services Center Construction \$275,000 Program Administration, \$85,200 Housing Rehabilitation, \$9,400 Allocation total \$494,000. On Tuesday April 13, at 7 p.m. in the Board meeting room located at the Summit on the Park Community Center 46000 Summit Parkway, Canton Michigan 48188, the Board of Trustees will hold a public hearing to consider the adoption of the Action Plan. Written comments or requests for information should be directed to Gerald Martin Community Services Division, 1150 S Canton Center Road Canton Michigan 48188 (734) 394-5194 Ex 5194. TERRY G BENNETT, Clerk. Publish March 18 & 25 2004.

NOTICE PLYMOUTH CHARTER TOWNSHIP RESIDENTS. If you experience an overflow of backup of a sewage disposal system or storm water system you must file a written claim with the Plymouth Charter Township Department of Public Works within 45 days after the overflow or backup was discovered. Notice should be mailed to Plymouth Charter Township Department of Public Works, 46555 Port Street Plymouth Michigan 48170. Failure to provide the written notice will prevent recovery of damages. Contact the Department of Public Works 734 453 8131, Extension 21 for assistance immediately upon discovery of an overflow or backup. Thank You PLYMOUTH CHARTER TOWNSHIP DEPARTMENT OF PUBLIC WORKS. MARILYN MASSENGILL, CMC Clerk Charter Township of Plymouth. Publish March 21 & 25 2004.

CHARTER TOWNSHIP OF CANTON REQUEST FOR BID. NOTICE IS HEREBY GIVEN that the Charter Township of Canton, 1150 Canton Center S, Canton, Michigan will accept sealed bids at the Office of the Clerk up to 3:00 p.m. April 8th 2004 for the following: LEAGUE AWARDS - CANTON SOFTBALL CENTER. Bid forms may be picked up at the Finance and Budget Department counter or you may contact Mike Sheppard at (734) 394 5225. All bids must be submitted in a sealed envelope clearly marked with the proposal name company name address and telephone number and date and time of bid opening. The Township reserves the right to accept or reject any or all proposals. The Township does not discriminate on the basis of race color national origin sex religion age or disability in employment or the provision of services. TERRY G. BENNETT, CLERK. Publish March 25 2004.

NOTICE OF PUBLIC HEARING CHARTER TOWNSHIP OF PLYMOUTH PLANNING COMMISSION PROPOSED MASTER PLAN AMENDMENT. ACTION: CONSIDER A PROPOSED AMENDMENT TO THE MASTER PLAN OF THE CHARTER TOWNSHIP OF PLYMOUTH, WAYNE COUNTY TO CHANGE THE FUTURE LAND USE MAP DESIGNATION OF A 5 ACRE SITE, DESCRIBED AS TAX ID 036 99 0024 0000, FROM RESIDENTIAL HIGH DENSITY TO RESIDENTIAL LOW INTERMEDIATE DENSITY. DATE OF HEARING: April 21 2004. TIME OF HEARING: 7 00 PM. PLACE OF HEARING: Plymouth Township Hall 42350 Ann Arbor Road. NOTICE IS HEREBY GIVEN that pursuant to Michigan Public Act 168 of 1959 as amended the Planning Commission of the Charter Township of Plymouth will hold a public hearing at 7 00 p.m. on April 21 2004, for the purpose of considering a proposed amendment to the Master Plan of the Charter Township of Plymouth Wayne County to change the Future Land Use Map designation of a 5 acre site described as Tax ID 036 99 0024-0000, from Residential High Density to Residential Low Intermediate Density. Please Note This amendment is intended to correct an oversight and does not constitute a new policy and does not reflect changed circumstances. The public hearing will be held to explain the proposed Master Plan amendment to the public. All interested parties are welcome to attend and present their comments. NOTICE IS FURTHER GIVEN that the proposed Master Plan amendment may be examined at the Plymouth Township Division of Public Services Building Community Development Department during regular business hours from 8 00 A.M. To 4 30 P.M. Application 1833 Written comments will be received prior to the meeting and may be mailed to 46555 Port Street Plymouth MI 48170, or call 734-453-8131, ext. 37. The meeting will be held in the Meeting Room at Township Hall which is located at 42350 Ann Arbor Road Plymouth, MI 48170. At the public hearing, the Planning Commission may approve the Master Plan amendment as proposed, or as may be amended. KENDRA BARBERENA, Secretary Planning Commission. PLEASE TAKE NOTE The Charter Township of Plymouth will provide necessary reasonable auxiliary aids and services such as signers for the hearing impaired and audio tapes of printed materials being considered at all Township meetings to individuals with disabilities at the meetings/hearings upon one week notice to the Charter Township of Plymouth by writing or calling the Supervisor's Office 42350 Ann Arbor Road, Plymouth MI 48170 Phone (734) 453-8340 TDD users 1-800-849-3777 (Michigan Relay Service). Publish March 25 & April 15 2004.

NOTICE OF PUBLIC HEARING CHARTER TOWNSHIP OF PLYMOUTH PLANNING COMMISSION PROPOSED ACTION: AMEND THE ZONING MAP OF THE TOWNSHIP. REZONE FROM: R 1 E Single Family Residential District Minimum 1 acre lot. REZONE TO: R 1 H Single Family Residential District Minimum 1/2 acre lot. DATE OF HEARING: Wednesday, April 21, 2004. TIME OF HEARING: 7 00 PM. PLACE OF HEARING: Plymouth Township Hall 42350 Ann Arbor Road. NOTICE IS HEREBY GIVEN that the Planning Commission of Plymouth Charter Township has received a petition to rezone parcel R78 046 99 0003 000 from R 1 E, Single Family Residential District to R 1 H, Single Family Residential District. AMENDED ZONING MAP NO 145 Charter Township of Plymouth, Wayne, Michigan. LEGAL DESCRIPTION: For parcel descriptions, see tax records based on Tax ID No. R78-046-99-0003-000. NOTICE IS FURTHER GIVEN that the proposed amendment to the zoning map of the Township may be examined at the Plymouth Township Division of Public Services Building Community Development Department during regular business hours from 8 00 AM to 4 30 PM. Application 1830 Written comments will be received prior to the meeting and may be mailed to 46555 Port Street Plymouth MI 48170, or call 734-453-8131, ext 37. The meeting will be held in the Meeting Room at Township Hall which is located at 42350 Ann Arbor Road Plymouth Township, MI 48170. At the public hearing, the Planning Commission may recommend rezoning of the subject property to any use allowable under the provisions of the Plymouth Township Zoning Ordinance No 83. KENDRA BARBERENA, Secretary Planning Commission. PLEASE TAKE NOTE The Charter Township of Plymouth will provide necessary reasonable auxiliary aids and services such as signers for the hearing impaired and audio tapes of printed materials being considered at all Township meetings to individuals with disabilities at the meetings/hearings upon one week notice to the Charter Township of Plymouth by writing or calling the Supervisor's Office 42350 Ann Arbor Road, Plymouth MI 48170 Phone (734) 453-8340 TDD users 1 800 849 3777 (Michigan Relay Service). Publish March 25 & April 15 2004.

NOTICE OF PUBLIC HEARING CHARTER TOWNSHIP OF PLYMOUTH PLANNING COMMISSION PROPOSED ACTION: AMEND THE ZONING MAP OF THE TOWNSHIP. REZONE FROM: R 1 S Single Family Residential District. REZONE TO: OS Office Service District. DATE OF HEARING: Wednesday, April 21, 2004. TIME OF HEARING: 7 00 PM. PLACE OF HEARING: Plymouth Township Hall 42350 Ann Arbor Road. NOTICE IS HEREBY GIVEN that the Planning Commission of Plymouth Charter Township has received a petition to rezone parcel R78 056 99 0030 002 from R-1-S, Single Family Residential District to OS, Office Service District. The property address is 45600 Joy Road Application 1826. AMENDED ZONING MAP NO 144 Charter Township of Plymouth, Wayne, Michigan. LEGAL DESCRIPTION: For parcel descriptions, see tax records based on Tax ID No. R78-056-99-0030-002. NOTICE IS FURTHER GIVEN that the proposed amendment to the zoning map of the Township, may be examined at the Plymouth Township Division of Public Services Building, Community Development Department, during regular business hours from 8 00 AM to 4 30 PM. Written comments will be received prior to the meeting and may be mailed to 46555 Port Street, Plymouth, MI 48170 or call 734-453-8131, ext. 37. The meeting will be held in the Meeting Room at Township Hall which is located at 42350 Ann Arbor Road Plymouth Township, MI 48170. At the public hearing, the Planning Commission may recommend rezoning of the subject property to any use allowable under the provisions of the Plymouth Township Zoning Ordinance No 83. KENDRA BARBERENA Secretary Planning Commission. PLEASE TAKE NOTE The Charter Township of Plymouth will provide necessary reasonable auxiliary aids and services such as signers for the hearing impaired and audio tapes of printed materials being considered at all Township meetings to individuals with disabilities at the meetings/hearings upon one week notice to the Charter Township of Plymouth by writing or calling the Supervisor's Office 42350 Ann Arbor Road, Plymouth MI 48170 Phone (734) 453-8340 TDD users 1 800 849 3777 (Michigan Relay Service). Publish March 25 & April 15 2004.

CHIEFS

FROM PAGE B1

notably on the offensive end Andrea Johnson, an all-WLAA selection at sweeper as a sophomore last season, will move up top, where her hard shot should make her dangerous. She'll be joined by senior Rachel Perry, a team co-captain who started last year, and sophomore Lisa Ealy, who played extensively last season as a freshman.

"I think Johnson will do a good job for us," said Smith. "She shoots well. Rachel causes problems for people up there and Ealy is experienced, too."

Moving Johnson up top leaves a hole on defense, one Smith plans to fill with co-captain Elizabeth Alexander, a senior. Others who figure to play prominent roles on defense are seniors Katie Esper, also a co-captain, Kristen Holden and Megan Romer, who played sparingly last year, junior Molly Priebe, who divided her time between outside midfield and defense last season, and sophomore Al Lindow, who started on defense as a freshman.

In the midfield, team co-captain Katie Mills, a senior, returns on the outside. Others who will contribute heavily are

juniors Bailey Fagan at attacking midfielder, a position she shared with Marsh last year, and Katie Raker, who was at stopper last season but will share the attacking midfield spot with Fagan this year.

Christie Daniels, also a junior, played extensively at outside midfield last season. Kelsy Zemański, a sophomore, will be at outside midfield and some defensive midfield.

Brittany Cervi, a junior, will take over in goal for the graduated Wolcott. She played just two matches last season, but Smith is confident she can handle it. All she needs, he said, is big-game experience. She'll be OK.

Others who will have an impact are junior defenders Colette Gillman and Stephanie Price, sophomore defender Laura Gibson, freshman midfielder Rebecca Houdek, and junior keeper Pam Wisniewski.

"We could be very good," Smith said. "Of course, you always like to think that."

In the WLAA's Lakes Division, Livonia Stevenson and Salem figure to be the teams to beat. In the Western Division, Canton will be challenged by Northville and Livonia Franklin for top honors.

If the Chiefs can match last season's scoring process and Cervi can replace Wolcott, they'll be up there again.

SALEM

FROM PAGE B1

who divided time in goal last season with Jones. Then there are juniors Kathryn Wheatley and Kelly Lepper, who will share the team captaincy with Falcusan and Sarkesian. Wheatley is a defender, Lepper a midfielder.

Megan McCarthy, a junior forward who was one of the Rocks' top scorers last season, also returns. So do senior midfielders Kim Towne, Alicia Hay and Jennifer Murray, junior midfielders Amy Gzicki and Jane Dewitt, senior defender Halle Burton, sophomore defender Kristin March, and sophomore forward Tara Duncan. All played considerably last year.

Rejoining the team is senior defender Genna Foster, who would have started last year if she hadn't suffered a torn anterior cruciate ligament, sidelining her for the season. She could start on defense this season.

Other newcomers who will contribute are junior midfielder Ashley Stoychoff, junior defender Christine Wheatley (Kathryn's twin sister), Katie Welch and Lauren Boothroyd,

and junior keeper Alyssa Guern.

Any one of them could (start), Nora noted. "We're a deep team in terms of skill and understanding of the game."

But are they as good as last season's WLAA title team? "I think we're better, because of what we went through last year," Nora said. "We're stronger physically, and I think we have even more of a team-first attitude."

His team should cause opponents all sorts of problems. "Our depth for sure," the Salem coach said. "We're a pretty quick team, we have some speed. We have the ability to defend and our counterattacking is good."

Still, Livonia Stevenson, with Melissa Dobbyn back, remains a force in the WLAA's Lakes Division, and Canton, Northville and Livonia Franklin will be tough in the Western Division.

The question is, can Salem not just survive the regular season, which includes non-conference dates against state powerhouses Rochester, Troy and Saginaw Heritage, but make a run in the state playoffs?

"Maybe we're due, said Nora. It's not just wishful thinking, it could be prophetic.

Good pitching can't elevate MU

Won one, tied one, lost two — not exactly a sparkling record for the Madonna University softball team at the Bethel (Ind.) College Tournament last weekend.

The Crusaders saw their record slip to 14-6-2 with a split on Friday and a loss and a tie on Saturday. They were beaten 1-0 by Marian (Ind.) College, then shelled St. Francis (Ind.) College 16-0 on Friday.

On Saturday, Madonna lost 4-2 to Bethel before tying Indiana Wesleyan 1-1. In the loss to Bethel, the Crusaders managed just five hits — two by Jamie Bobrowski. Mary Warchuck drove in both their runs with a seventh-inning double.

Kelly Nilson took the loss, allowing four earned runs on six hits and three walks in six

innings. Somer Stillely was the winning pitcher for Bethel. Carole Holtz had a double and a home run with two RBI.

In the 1-1 tie with Wesleyan, Madonna's Shannon Noder pitched eight innings, surrendering one run on two hits and three walks, with 10 strikeouts. Arin Fowler, Krystal Shina and Bobrowski each had two hits for the Crusaders.

In Friday's 1-0 loss to Marian, Madonna managed just one hit off of Jenny Dinelli, a single by Warchuck. Nilson gave up an unearned run on three hits and a walk.

The Crusaders rebounded with their five-inning mercy of St. Francis. Emily Cunningham led the 13-hit attack with three hits, including a triple, four runs scored and two RBI.

CHARTER TOWNSHIP OF CANTON PUBLIC HEARING FY 2004 CDBG ACTION PLAN

On Tuesday April 13, at 7 p.m. in the Board meeting room located at the Summit on the Park Community Center 46000 Summit Parkway Canton Michigan 48188 the Board of Trustees will hold a public hearing to consider the adoption of the FY 2004 Community Development Block Grant action plan. Comment will be accepted on the following project proposals: First Step \$36,000, Growth Works \$8,800, Wayne County Neighborhood Legal Services \$10,100, Wayne Metropolitan Community Action Agency \$1,500, Volunteer Coordinator \$6,500, Summit Scholarship, \$1,500, Human Services Center Construction, \$275,000, Program Administration \$85,200, Housing Rehabilitation \$9,400. Allocation total \$434,000. Written comments or requests for information should be directed to Gerald Martin, Community Services Division, 1150 S. Canton Center Road, Canton Michigan 48188 (734) 394-5194, Ex 5194.

TERRY BENNETT Clerk

Published March 18 & 25 2004

CE08 95046

CHARTER TOWNSHIP OF CANTON ACCESS TO PUBLIC MEETINGS

The Charter Township of Canton will provide necessary reasonable auxiliary aids and services such as signers for the hearing impaired and audio tapes of printed materials being considered at the meeting to individuals with disabilities at the meeting/hearing upon two weeks notice to the Charter Township of Canton. Individuals with disabilities requiring auxiliary aids or services should contact the Charter Township of Canton by writing or calling the following:

David Medley, ADA Coordinator
Charter Township of Canton 1150 S. Canton Center Road
Canton MI 48188
(734) 394-5260

Published March 18 25 & 28 2004

CE08 95037

CHARTER TOWNSHIP OF CANTON REQUEST FOR BID

NOTICE IS HEREBY GIVEN that the Charter Township of Canton 1150 Canton Center S. Canton Michigan will accept sealed bids at the Office of the Clerk up to 3:00 p.m. April 8th 2004 for the following:

WEED CUTTING BID 2004

Bid forms may be picked up at the Finance and Budget Department counter or you may contact Mike Sheppard at (734) 394-5225. All bids must be submitted in a sealed envelope clearly marked with the proposal name, company name, address and telephone number and date and time of bid opening. The Township reserves the right to accept or reject any or all proposals. The Township does not discriminate on the basis of race, color, national origin, sex, religion, age or disability in employment or the provision of services.

TERRY G. BENNETT, CLERK

Published March 25 2004

CE8 99 4

PLANNING COMMISSION CHARTER TOWNSHIP OF CANTON NOTICE OF PUBLIC HEARING

PROPOSED AMENDMENT TO THE ZONING ORDINANCE OF THE CHARTER TOWNSHIP OF CANTON, WAYNE COUNTY MICHIGAN

NOTICE IS HEREBY GIVEN pursuant to Act 184 of the Public Acts of 1943 of the State of Michigan as amended, and pursuant to the Zoning Ordinance of the Charter Township of Canton that the Planning Commission of the Charter Township of Canton will hold a Public Hearing on Monday, April 19, 2004 in the **Chestnut Room, at Summit On The Park, 46000 Summit Parkway at 7:00 p.m.** on the following proposed amendment to the Zoning Ordinance:

ZONING ORDINANCE TEXT AMENDMENT CONSIDER REQUEST TO AMEND THE CANTON TOWNSHIP ZONING ORDINANCE

Amend Section 1.03 (Definition)
Commercial definition of Church, Synagogue, Temple, Mosque or Similar Religious Facility

Amend Section 6.02U (Site Development Standards for Non-Residential Uses)
Site development standards for religious institutions

Amend Section 6.08 (Site Development Standards for the Corporate Overlay District)
Create Section 6.10
Site Development Standards for the Central Business Overlay District (CBD)

Section 16.02A, C-2 (Community Commercial District)
Add Religious Institution as a permitted use in the C-2 District

Section 17.02A, C-3 (Regional Commercial District)
Add Religious Institution as a permitted use in the C-3 District

Section 19.02A, MRD/HRD (Mid-Rise and High Rise Development Districts)
Add Religious Institution as a permitted use in the MRD and HRD Districts

Section 20.02 A and B, O-1 (Office District)
Remove religious institutions as a special land use and religious institutions as a permitted land use in the O-1 Office District

Amend Section 21.00 LI-1 (Light Industrial)
Revise list of permitted and special land uses

Amend Section 22.00, LI-2 (Light Industrial)
Revise list of permitted and special land uses

Amend Section 21A.00, RP (Research Park)
Revise list of permitted and special land uses

Amend Section 23.00, GI (General Industrial)
Revise list of permitted and special land uses

Written comments addressed to the Planning Commission should be received at the Canton Township Administration Building 1150 Canton Center S. prior to Thursday April 15 2004 in order to be included in the materials submitted for review.

VIC GUSTAFSON, Chairman

Published March 25 & April 11 2004

CE08198108

WAYNE COUNTY DEPARTMENT OF PUBLIC SERVICES NOTICE OF PUBLIC HEARING

In accordance with the provisions of Section 18, chapter IV Act 283 of the Public Acts of 1909 as amended, seven or more freeholders have petitioned the County of Wayne to absolutely abandon and discontinue

All of Jewell Avenue 60 feet wide as dedicated for the use of the public in McMullan Brothers Huron Hills Subdivision being part of the NW 1/4 of the SW 1/4 of Section 21 T 3S R 8E Van Buren Township Wayne County Michigan as recorded in Liber 61 of plats on Page 54 Wayne County Records

Therefore it has been decided a Hearing will be held on Wednesday April 28 2004 at 10:00 a.m. at the Wayne County Department of Public Services 415 Chifford Street 3rd Floor Detroit Michigan 48226 and that a Hearing Examiner of the county shall hold said hearing and obtain all necessary facts and information concerning the advisability of either granting or denying said petition and shall report all findings of fact to the Board of Wayne County Commissioners

True copies of this notice are to be served, posted and published in accordance with the provisions of said Act No. 283 of 1909 as amended

WAYNE COUNTY DEPARTMENT OF PUBLIC SERVICES
Real Estate 3rd Floor
Attention: Curtis M. Brochue
415 Chifford Street
Detroit Michigan 48226
313 224 7759

Published March 25 & 28 2004

CE08 97080

SPECIAL SECTIONS WHERE

advertising opportunities are unfolding!



USE OUR MARKET TO TARGET YOUR MARKET



Call today to reserve your space and for more information!

PREMIER FINE HOMES
Issue Date April 18
Ad Close March 30

MIND BODY & SPIRIT
Issue Date April 22
Ad Close March 31

APARTMENT LIVING
Issue Date April 25
Ad Close April 16

SPRING HOME & GARDEN
Issue Date May 6
Ad Close April 19

SENIOR CITIZENS EXPO
MAY 19 at
SCHOOLCRAFT COLLEGE
Issue Date May 13
Ad Close April 1

HIT THE GREENS
Issue Date May 27
Ad Close May 12

plus:

WEEKLY FILTER Pure Entertainment!

MONTHLY Coupon books

ANYTIME Web links

Quality commercial printing

THE **Observer & Eccentric** NEWSPAPERS

WHERE HOMETOWN STORIES UNFOLD

OAKLAND COUNTY: 248-901-2500
ROCHESTER 248-651-7575 WAYNE COUNTY: 734-953-2153
WWW.HOMETOWNLIFE.COM

CE08191243.EPS

Ronald McDonald House

You Can Work Some Real Magic For The Ronald McDonald House®!

Stop by any Canton McDonald's® on any SUNDAY and you can get a good read and do a good deed...for the Ronald McDonald House® of Ann Arbor!

Just Come in any Sunday and buy a discounted copy of the Canton Observer and they'll donate all of the proceeds to the Ronald McDonald House® of Ann Arbor. That's EVERY Sunday...See You There!

THE **Observer & Eccentric** NEWSPAPERS

CE08190906

NOTICE OF PUBLIC HEARING CHARTER TOWNSHIP OF PLYMOUTH PLANNING COMMISSION

PROPOSED NEW ZONING ORDINANCE TEXT

ACTION: CONSIDER A NEW ZONING ORDINANCE TEXT TO REPLACE THE TEXT OF THE CHARTER TOWNSHIP OF PLYMOUTH ZONING ORDINANCE ORDINANCE NO 83, IN ITS ENTIRETY

DATE OF HEARING: Wednesday March 31 2004

TIME OF HEARING: 7:00 PM

PLACE OF HEARING: Plymouth Township Hall, 42350 Ann Arbor Road

NOTICE IS HEREBY GIVEN that pursuant to Michigan Public Act 184 of 1943 as amended the Planning Commission of the Charter Township of Plymouth will hold a public hearing at 7:00 p.m. on Wednesday March 31 2004, for the purpose of considering a comprehensive revision of the zoning ordinance text for the entire Charter Township of Plymouth. The new zoning ordinance text will replace the current Charter Township of Plymouth Zoning Ordinance Ordinance No. 83, in its entirety. Revisions to the zoning map for the Township will be considered at a separate Planning Commission public hearing on April 7 2004.

The public hearing will be held to explain the proposed Zoning Ordinance text to the public. All interested parties are welcome to attend and present their comments.

NOTICE IS FURTHER GIVEN that the proposed new zoning ordinance text may be examined at the Plymouth Township Division of Public Services Building Community Development Department during regular business hours from 8:00 A.M. to 4:30 P.M. Application 1677. Written comments will be received prior to the meeting and may be mailed to 46555 Port Street, Plymouth MI 48170, or call 734-453-8131 ext 37. The meeting will be held in the Meeting Room at Township Hall which is located at 42350 Ann Arbor Road, Plymouth, MI 48170. At the public hearing the Planning Commission may be recommended approval to the Township Board of Trustees of the new zoning ordinance text as proposed, or as may be amended.

PLEASE TAKE NOTE The Charter Township of Plymouth will provide necessary reasonable auxiliary aids and services such as signers for the hearing impaired and audio tapes of printed materials being considered at all Township meetings to individuals with disabilities at the meetings/hearings upon one week notice to the Charter Township of Plymouth by writing or calling the Supervisor's Office 42350 Ann Arbor Road Plymouth MI 48170 Phone (734) 453-3840 TDD users 1-800-849-3777 (Michigan Relay Service)

KENDRA BARBERENA Secretary
Planning Commission

Published March 4 & 25 2004

Find your favorite recipe each Thursday in Taste

GDBA tourney starts Saturday

The Greater Detroit Bowling Association will conduct its 90th annual championship tourney beginning Saturday, March 27 at Cloverlanes in Livonia.

Squad times are 9:30 a.m. and 1 p.m. for the tourney, which runs Saturdays and Sundays through April 25.

The tourney is open to all GDBA members and is handicapped based on 90 percent from 220. That means bowlers of all levels of abilities have a realistic chance to win.

First place in the team event pays \$5,000 with second paying \$2,500 based on 400 teams.

The entry fee is \$20 per person per event and a \$10 optional fee for all-events.

Individuals who organize 10 or more teams are eligible for a \$10 per team reward. As new twist this year, you can register and pay on-line at www.gdba.com (click on tournament information).

One of the most important individuals in your league is the secretary.

Except for the fact that many leagues now just pay the house for this service, there are plenty of good secretaries around.

It is almost a thankless job, much taken for granted. It is up to the secretary to attend the preseason association meetings and obtain supplies



Ten-Pin Alley

Al Harrison

They have to see that all sanction cards are fully filled out and sent in. They also must keep complete and accurate records of each game, figure the averages weekly, make up a weekly schedule and standings sheet, send in any awards to the association, assign subs, keep the league informed as to what's going on, along with upcoming activities.

There are so many fine secretaries who go above and beyond in making for a better league. The GDBA offers special awards each year for outstanding service in several areas. This includes the Secretary of the Year award.

Anyone may submit an entry based on at least two years in office within the GDBA including the current season.

Other items considered include: 1. Does he/she see that a preseason meeting is held of the leagues Board of Directors? 2. Does he/she make every effort to see that the league is filled each year? 3. Does he/she submit the sanction cards to GDBA within the 30 day grace

period? 4. Are the average sheets for Dec 31 and the year-book provided to the associations within two weeks of date requested? 5. Are awards requested and presented to recipients in a timely manner? 6. Is he/she knowledgeable of league and ABC rules? 7. Is he/she tactful and fair in settlement of league disputes? 8. Does he/she support GDBA tournaments and encourage league members to participate? 9. Does he/she provide the captains with a complete schedule for the season? 10. Does he/she attend or have league representative attend the semi-annual and annual meetings of the council of delegates?

Anyone interested in submitting a league secretary for consideration should include samples of league sheets or any other communications the secretary provides to the members, along with a description of whether the above criteria are adhered to.

Any other above and beyond the call of duty items that the prospective candidate does would be very helpful to the committee in rendering its decision. Applications must be received no later than April 1.

Al Harrison is a resident of Livonia and a director of the GDBA. He can be reached at (248) 477-1839 or e-mail at tenpinalley@sbcglobal.net.

SPORTS ROUNDUP

BASEBALL TRYOUTS

The WaCo Wolves U-9 travel baseball team will hold winter tryouts for the 2004 season. The team will play about 50-60 games during the season plus a World Series.

For more information, please call Bill Hardin at (734) 516-3723.

The Michigan Indians U-14 travel baseball tryouts will be 2:30-3:30 p.m. on consecutive Saturdays, March 20 and March 27, at Total Baseball in Wixom. Aaron Kneiper, former pro player and full-time baseball instructor, will coach this team.

The team will play in the Michigan Superior League and six tournaments, with indoor training at Total Baseball. Please call in advance. Aaron Kneiper, (248) 219-8205, or e-mail him at arkneiper@aol.com.

The Canton Mustangs U12 travel baseball team needs a few players for their 2004 squad. The Mustangs play in the Kensington Valley Baseball and Softball Association League, with 20 league games and 4-5 weekend tournaments (approximately 35 games in total). To be eligible, the player cannot turn 13 until after July 31, 2004.

For tryout appointments, call Jeff Gatt at (248) 752-7376.

BURTON'S

Plumbing & Heating

BATH and KITCHEN REMODELING

FREE ESTIMATES
Visit Our Full Kitchen and Bath Showroom

(Same location since 1975)
34224 Michigan Avenue
Wayne, Michigan 48184
(734) 722-4170

- Licensed Master Plumber
- Ceramic Tile Installed
- Quality Materials and Workmanship

Find your favorite recipes each Thursday in Taste

THINK BIG
SALES EVENT

NOW GET LARGER-THAN-LIFE SAVINGS ON EVERY LINCOLN AND MERCURY.



2004 LINCOLN TOWN CAR SIGNATURE

RED CARPET LEASE FOR A/D/Z FORD EMPLOYEES, RETIREES AND ELIGIBLE FAMILY MEMBERS

\$434 A MONTH/ 36 MONTHS

\$2,504 CASH DUE AT SIGNING* (AFTER \$5,500 CASH BACK INCLUDING \$500 AARP BONUS CASH)**

INCLUDES REFUNDABLE SECURITY DEPOSIT AND ACQUISITION FEE EXCLUDES TAX, TITLE AND LICENSE FEES

LINCOLN TOWN CAR SIGNATURE A PLAN PRICE STARTING AT **\$32,358**** AFTER \$5,500 CASH BACK



2004 MERCURY GRAND MARQUIS GS

RED CARPET LEASE FOR A/D/Z FORD EMPLOYEES, RETIREES AND ELIGIBLE FAMILY MEMBERS

PRE-PAY A TWO YEAR LEASE FOR **\$6,865*** (AFTER \$5,250 CASH BACK INCLUDING \$500 AARP BONUS CASH, \$1,250 FORD CREDIT CASH AND \$500 A/D/X/Z BONUS CASH)**

SECURITY DEPOSIT NOT REQUIRED INCLUDES ACQUISITION FEE EXCLUDES TAX, TITLE AND LICENSE FEES

A PLAN PRICE STARTING AT **\$17,960**** AFTER \$4,750 CASH BACK



2004 LINCOLN LS V-6 PREMIUM

RED CARPET LEASE FOR A/D/Z FORD EMPLOYEES, RETIREES AND ELIGIBLE FAMILY MEMBERS

\$349 A MONTH/ 39 MONTHS

\$2,319 CASH DUE AT SIGNING* (AFTER \$4,500 CASH BACK)

INCLUDES REFUNDABLE SECURITY DEPOSIT AND ACQUISITION FEE EXCLUDES TAX, TITLE AND LICENSE FEES

LINCOLN LS V-6 PREMIUM A PLAN PRICE STARTING AT **\$27,926**** AFTER \$6,000 CASH BACK

LINCOLN LS V-6 LUXURY A PLAN PRICE STARTING AT **\$23,548**** AFTER \$6,000 CASH BACK

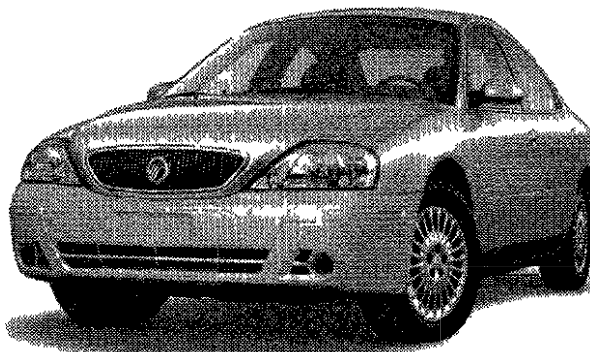

2004 MERCURY SABLE GS

FOR RETURNING LESSEES A/D/Z FORD EMPLOYEES, RETIREES AND ELIGIBLE FAMILY MEMBERS

FlexBuy

\$199 A MONTH FOR THE FIRST 36 MONTHS | **\$249** A MONTH FOR THE FINAL 30 MONTHS*

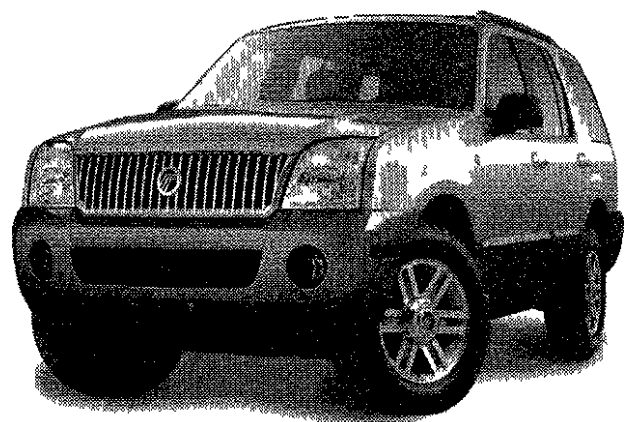

2004 MERCURY MOUNTAINEER V-6 CONVENIENCE AWD

RED CARPET LEASE FOR A/D/Z FORD EMPLOYEES, RETIREES AND ELIGIBLE FAMILY MEMBERS

\$279 A MONTH/ 36 MONTHS

\$2,219 CASH DUE AT SIGNING* (AFTER \$4,250 CASH BACK INCLUDING \$1,250 FORD CREDIT CASH)**

INCLUDES REFUNDABLE SECURITY DEPOSIT AND ACQUISITION FEE EXCLUDES TAX, TITLE AND LICENSE FEES

MERCURY MOUNTAINEER V-6 CONVENIENCE AWD A PLAN PRICE STARTING AT **\$24,804**** AFTER \$4,250 CASH BACK

<p>SEE YOUR METRO DETROIT LINCOLN MERCURY DEALER</p>	<p>ANN ARBOR Sesi 2100 W Stadium Blvd at L. bery (734) 668 6100 sesilm.com</p>	<p>CLINTON TOWNSHIP Stu Evans Lakeside 17500 Hall Rd at Romeo Plank (586) 840 2000 stuevanslakeside.com</p>	<p>DEARBORN Jack Demmer 21531 Michigan Ave Between Southfield & Telegraph (313) 274 8800 demmerlm.com</p>	<p>DETROIT Bob Maxey 16901 Mack Ave at Cad euz (313) 885 4000 bobmaxeylm.com</p>	<p>DETROIT Park Motor 18100 Woodward Ave Oppos to Palmer Park (313) 869 5000 parkmotorslm.com</p>	<p>GARDEN CITY Stu Evans Garden City 32000 Ford Rd Just West of Merriman (734) 425 4300 stuevansgardencity.com</p>	<p>NOVI Varsity 49251 Grand River 1.96 at W xom Rd (Ex 1159) Two Exits West of 12 Oaks Mall (248) 305 5300 varsitylm.com</p>
	<p>PLYMOUTH Hines Park 40601 Ann Arbor Rd at I 275 (734) 453 2424 hinesparklm.com</p>	<p>ROCHESTER HILLS Crissman 1185 South Rochester Rd Between Ham l n & Avon Rd (248) 652 4200 crissmanlm.com</p>	<p>SOUTHFIELD Star 24350 West 12 Mile Rd at Telegraph (248) 354 4900 starlm.com</p>	<p>SOUTHGATE Southgate 16800 Fort Street at Pennsylvan a (734) 285 8800 southgateincolnmercury.com</p>	<p>STERLING HEIGHTS Crest 36200 Van Dyke at 15 1/2 Mile Rd (586) 939 6000 crestlinmerc.com</p>	<p>TROY Bob Borst 1950 West Maple Troy Motor Mall (248) 643 6600 borstlm.com</p>	<p>YPSILANTI Sesi 950 East Michigan 9 Miles West of I 275 (734) 482 7133 sesilm.com</p>

For latest A/D/Z offers on all Lincoln Mercury vehicles, it's time to visit LMAPlan.com

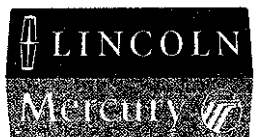

*Call 1 888 56 LEASE for details. Residency restrictions apply. Take delivery from dealer stock by 3/31/04. ** Starting At' prices exclude tax, title and registration fees. See dealer for their price. ***Cash back on Town Car and Grand Marquis includes \$500 AARP Bonus Cash. Proof of AARP membership required. Offer cannot be combined with any private offers. Cash back on Mountaineer V6 Convenience and Grand Marquis includes \$1250 Ford Credit Cash for approved Ford credit purchase or lease contracts. 166 months with \$1000 down after \$1000 cash back excluding tax, title and license fees at 0.9% APR. \$200 payment calculates when FlexBuy rebate of \$1,800 is applied to the first 36 months. Take new retail delivery from dealer stock by 3/31/04. See dealer for their price, qualifications and complete details.

At Home

INTERIOR DESIGN ■ DIY ■ GARDENING

Inside
Monte Nagler C2
Joe Gagnon C5
Dr Brad Davis C7
www.hometownlife.com

Accents

Spouting off

The constant dripping of a leaky faucet can cost you a good night's sleep. Morris and James Carey of AP Weekly Features suggest using about a foot of string as a temporary solution when a permanent repair can't be made on the spot.

Tie the string around the spout and allow the extra length to hang just below the drip. The water will trickle silently down the string and into the drain.

Let it roll

Garfield built his comic career out of being a fat cat, but feline obesity is no laughing matter. According to a study carried out at Cornell University, some 25 percent of pet cats are overweight, running the risk



of developing diabetes, lameness, skin problems and liver disease.

Now there's a new concept in cat toys that the toy's creators hope will motivate your feline to get off the couch and start exercising — the OurPet's Bubble Mouse.

The Bubble Mouse consists of a motorized mouse inside a clear plastic ball. When the mouse is turned on, it causes the plastic ball to start rolling.

Propelled by the tenacious mouse inside, the ball rolls off walls, furniture and other obstructions, changing its direction to roll across the floor some more. Cats chase and swat at the moving mouse-in-a-ball in an attempt to capture it.

"If you've ever watched a cat stalking prey outdoors, you know how intensely they get involved in this activity," said Dr. Steve Tsengas, president of OurPet's.

"With the Bubble Mouse, you can bring a simulated version of the hunting experience indoors to your cat. Even cats that lose interest in most toys are motivated by the Bubble Mouse."

The fact that the little mechanized mouse also has a strong catnip scent also makes cats stand up and take notice.

Made from durable, easy-to-clean non-toxic plastic, the Bubble Mouse cannot be opened by cats. While cats may play with the catnip-filled mouse outside of its protective ball under supervision, only humans can twist open the ball to release it. When the mouse is returned to the ball, a secure snap prevents the cat from opening it again.

The Bubble Mouse has a suggested retail price of \$14.99, and is available at leading pet stores. One AAA battery is required.

For more information about the Bubble Mouse, contact OurPet's at (800) 565-2695, or visit OurPet's Web site at www.ourpets.com



Spring blooms at show

Joe Peterson's hobby started at a shopping mall. Diane Burton first saw her new love at Cranbrook. Dick Wagner just plain liked them.

Burton, Peterson and Wagner love growing orchids. All three have greenhouses and enjoy their blooms at this time of year, gearing up for the Michigan Orchid Society's

What: The Michigan Orchid Society Palm Sunday Show. Featuring 20 exhibits of orchids and 800 plants on display. Orchid displays and plants for sale, cultural information, raffle and growing tips. Society is a nonprofit organization with more than 200 members. Membership is \$15 a year.

When: Mall hours Saturday and Sunday April 3-4

Where: Laurel Park Place Mall, Six Mile and Newburgh Road, just east of I-275 Six Mile interchange.

Palm Sunday Show, this Saturday and Sunday at Laurel Park Place in Livonia. Peterson, who handles publicity for the 200-member Michigan Orchid Society, has an 8- by 18-foot greenhouse, a gift for his 40th birthday nine years ago. He has at least 100 different species growing in the greenhouse at his home in Troy.

The first encounter with orchids was at the Tel-Twelve mall 18 years ago, before Peterson and his wife married. "We went shopping, and I hate shopping," he

said. "But I went, and I bought an orchid plant at the show. Then on our honeymoon in Hawaii, I bought 10 more." He's been hooked ever since.

Peterson expects exhibitors will have

PLEASE SEE ORCHIDS, C3

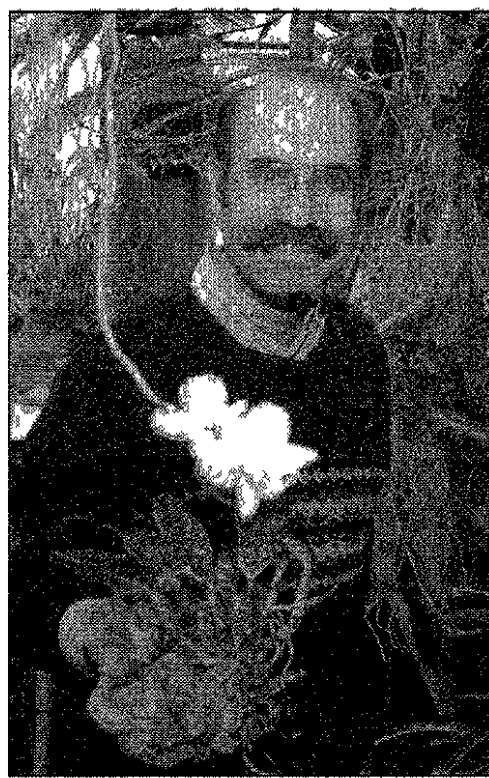

Joe Peterson of the Michigan Orchid Society shows off one of the scores of orchids inside his greenhouse at his home in Troy. Peterson will judge the exhibits at the Palm Sunday Michigan Orchid Society Show April 3 and 4 in Livonia.

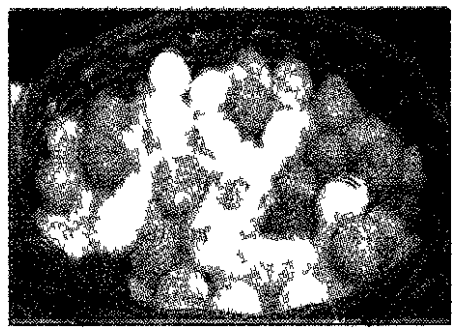

JADWIGA ZAJACZKOWA

Dyes made from natural herbs and plants can give eggs beautiful color.

Decorating methods celebrate season

The Ukrainian egg decorating art of pysanky, centuries old, is taught to new students every year.

All ages learn how to cover a pysanka with a design that can be intricate, symbolic or simply beautiful.

(Pysanka, a Ukrainian Easter egg, is pronounced PIS-ahn-kah. The word comes from the Ukrainian word

EGGS-CITING EVENTS

■ Coloring eggs with herbs and plants will be demonstrated at an open meeting of the Evening Herb Study Group of the Friends of the University of Michigan Matthaei Botanical Gardens, 7 p.m. Monday, April 5, at the Gardens in Room 125 (in the opposite end of the building from the conservatory). The Gardens are at 1800 N. Dixboro Road in Ann Arbor. Admission is free.

■ The Ann Arbor Art Center will offer a workshop on wax resist egg decorating, showing how to use the Ukrainian method of egg decorating to design eggs to celebrate spring. 12:30 p.m. Sunday, April 25. Cost is \$12. Registration is recommended. Call (734) 994-8004 or visit www.annarborartcenter.org.

pysaty, which means "to write."

Pysanky is the plural of pysanka.)

After Pam Miley, an instructor at the Ann Arbor Art Center, took her first pysanky class, "I thought, 'This would be cool to do with kids,'" she said.

Miley taught a 4-year-old girl the traditional craft last year, the youngster could decorate the eggs in the wax-resist method herself.

Another year, Miley's students included a family of parents and three

children — a 4-year-old and two college-age. The mother had asked the family to take the class as a gift to her.

The pysanky process is similar to the method of batik on fabric. In batik, designs are dyed on cloth by coating with removable wax the parts not to be dyed.

"What you do is apply the wax to the egg in stages," Miley said.

In pysanky, a tool called a kistka is used to heat beeswax and apply the melted wax to the surface of the egg. The traditional kistka features a tiny copper funnel wired onto a wooden dowel. (Today electric kistky are available as well.) Colors are applied in layers of dyes.

To make a pysanka, start with the white shell.

Decide what parts of the egg you want to remain white in the completed design. Using the kistka like a stylus, draw on the egg in these areas. The wax, which hardens almost immediately, will seal the white underneath it.

Then dye the egg with the first color, which is usually yellow.

Decide what parts of the design will be yellow, and cover them with the melted wax. Dye the egg with the next color, which is usually orange.

"Keep going through stages of darker and darker colors," said Miley, who gets her pysanky kits from The Ukrainian Gift Shop Inc. in Minnesota.

The shop's Web site says that not more than five colors are customarily used, as too many colors will affect the brilliance of the individual dyes.

Wax isn't applied for the final color. After the shell has dried from the last dye, hold part of the egg up to a candle

PLEASE SEE EGGS, C4

MARKET PLACE

Submissions

Do you have a special item you'd like to showcase in Marketplace on the front of At Home? We'd like to feature it!

Send a photo or slide of the piece along with information to Ken Abramczyk, At Home editor, Observer & Eccentric Newspapers, 805 E. Maple, Birmingham 48009.

It's about time ...

and weather. The Weatherton semicircular metal clock by Howard Miller® features a hygrometer that measures humidity and a thermometer. The clock is finished in brushed and polished silver-tone, the dials have circular, diamond-cut numeral rings, black Roman numerals, black hour and minute hands, and silver second and alarm hands. A full felt bottom protects the tabletop. A quartz movement includes the battery.

The Weatherton measures 3 3/4 inches high, 8 inches wide and 2 inches deep, and retails for around \$43.95.

For a free copy of Howard Miller's guide to the finer points of clocks and collectors' cabinets, or to find a store near you, call (800) 873-0506 or visit www.howardmiller.com

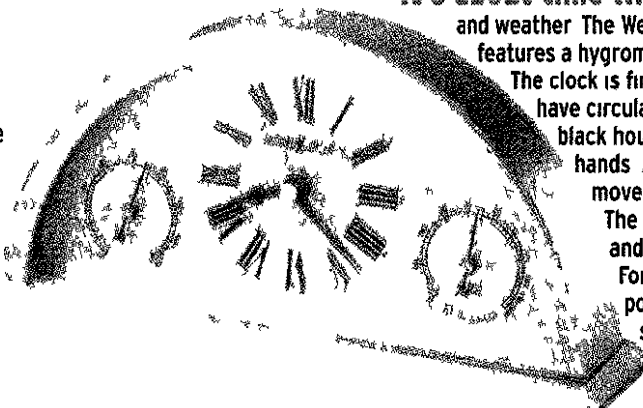



JOHN DEERE

Buy now, pay later.
Much, much, much, much later.

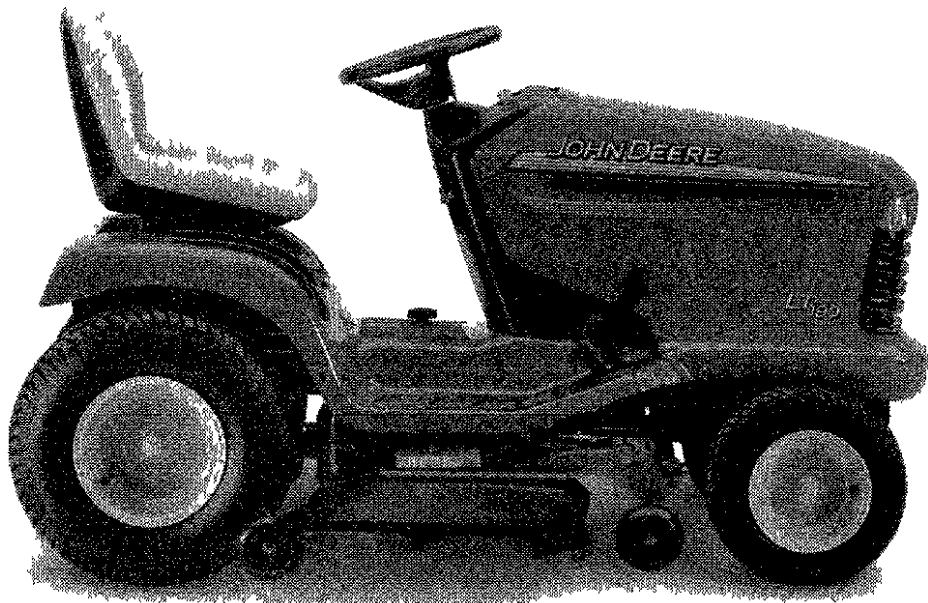

NOTHING RUNS LIKE A DEERE™

\$0 Down 0% APR Interest 0 Payments for one year!
Hurry, offer ends soon.

Right now buy almost any John Deere lawn or garden tractor and pay nothing for a full year! And you can experience our exclusive Edge™ Cutting System for a professional quality cut expert support from your local neighborhood John Deere dealer and the legendary reliability durability and precision of a John Deere. So visit your nearest dealer today and enjoy a John Deere this season without paying until next season. www.JohnDeere.com/Homeowners

Canton Power Equipment
Canton
46600 Ford Road
(734) 453-0295

Commercial Lawnmower
Livonia
32098 Plymouth Road
(734) 525-0980

D&G Equipment
Howell (517) 546-6000
Waterford (248) 674-2607
Highland (248) 887-2410

Weingartz
Utica
46061 Van Dyke Ave
(586) 731-7240
Farmington Hills
39050 Grand River Ave
(248) 471-3050

*Offer ends May 2, 2004. Subject to approved credit on John Deere Credit Reviewing Plan a service of FPC Financial. A \$0 down payment is required. After promotional period, finance charge will begin to accrue at 2.9% APR. A \$0.50 per month minimum finance charge may be required. Other special rates and terms may be available, including retail merchant financing and financing to commercial users. Available at participating dealers. Excludes all John Deere tractors. John Deere's green and yellow color scheme, the leaping deer symbol and JOHN DEERE are trademarks of John Deere & Company. ©2003 John Deere & Company. Equal Opportunity Lender.

Keep clutter under control

In past columns, I've discussed the need to keep things simple. When you express a single idea and keep backgrounds simplified, you make sure the viewer's attention will be directed towards the main subject.

But there are times when using the environment as a backdrop can add an extra dimension to your pictures.

You might even say that "controlled clutter" can add important information to a photograph and make it easier to understand and relate to.

In a picture of a person, for example, what do objects included tell us about the subject - interests, job, or social status? You'll often see environmental portraits where much is learned about the person by the "clutter" in the finished picture.

The surroundings tell us a lot about the individual.

This applies to non-portrait photographs as well. The picture shown here is a 200-year-old cabin in Pine Mountain, Georgia. At first glance, the shot may appear too cluttered. But notice how all the elements work together to produce a photograph with lots of impact.

The dark window is located off center and the chairs, broom, axe, and saddle bag are placed in strategic locations to make the picture "flow" and produce an overall rustic feeling. Even the pile of logs behind the left chair was carefully positioned to add to the effect.

All in all, this is a photograph that tells a story of the past. The picture works because of "controlled clutter," the use of complementary items to compose a shot.

As in all good photography, pay attention to

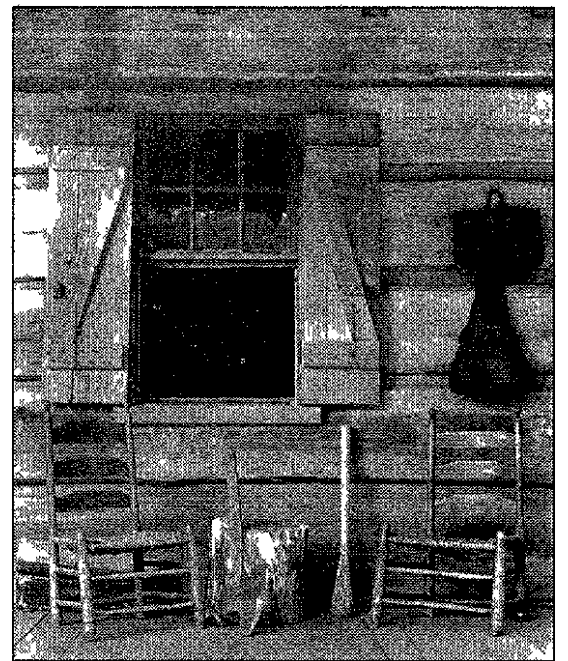

This photograph draws its impact and tells its story through the use of "controlled clutter." Notice how carefully the elements in the composition are balanced and how they complement each other.

lighting and camera angle and choose the lens that will enable you to include all that you want in the viewfinder. Be sure to use an aperture small enough to place all items in your composition in the camera's depth-of-field.

So organize your photographic thinking by adding a little "clutter" to your shots.

Monte Nagler is a fine art photographer based in Farmington Hills. You can leave him a message by dialing (734) 953-2047 on a touch tone phone. His fax number is (248) 644-1314.

HOME CALENDAR

Hummel artist

Christina Gohl, the talented artist from the W. Goebel Porzellanfabrik in Germany, will demonstrate the handpainting process involved in creating beloved M.I. Hummel figurines. 4-8 p.m. Thursday, March 25, at Heslop's, 22790 Heslop Drive in Novi (phone: (313) 522-1850). Admission is free. The event is open to the public. As part of her presentation, the ceramic painter will display the different tools and materials used to create the world-famous M.I. Hummel figurines. Gohl will also sign individual

Basement remodeling

Oakland Builders Institute will offer a class on basement remodeling Monday and Wednesday, March 29 and 31, through Birmingham Community Education. The class will explain all facets of basement remodeling, including plan

ning, meeting building codes, estimating materials, the basics of home construction, and finishing techniques. The instructor will review your plans. Fee is \$90 plus \$8 book fee payable to the instructor. For more information, call (248) 203-3800.

If you have an item for the calendar, please submit it at least two weeks in advance of the date it should be published. Send to Ken Abramczyk, At Home Editor, Eccentric Newspapers, 36251 Schoolcraft, Livonia, MI 48150, or e-mail kabramczyk@oehomecomm.net.

Unbelievable Prices!

BUY WITH CONFIDENCE!
1956 48 YEARS 2004
Serving Metro Detroit
for 48 Years!

Granite Countertops
Lowest Advertised
Price in the
Tri-County Area

Granite 3cm thick!

- \$38.95 S/F Rosa Beta
- \$38.95 S/F Luna Pearl
- \$38.95 S/F Mystic Green
- \$38.95 S/F Topazio Ouro
- \$38.95 S/F Verde Tunas
- \$42.95 S/F S Cecilia D
- \$42.95 S/F Verde Butterfly
- \$45.95 S/F Uba Tuba
- \$45.95 S/F Baltic Brown
- \$45.95 S/F Gold Butterfly
- \$45.95 S/F White Butterfly
- \$49.95 S/F Impala Black

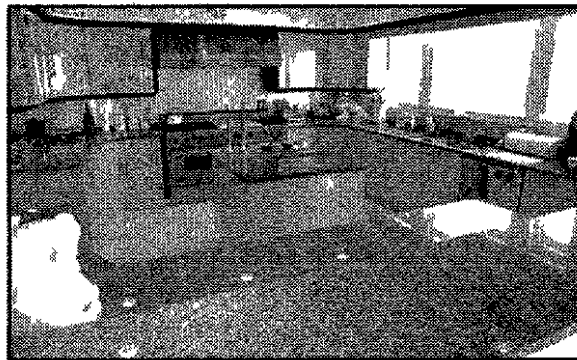

13x13
Porcelain Tile
\$1.61 S/F
15 colors available

All prices include installation, full bullnose or straight polished edge 20 s/f minimum. Machine finished edges only (while supplies last).

Watch for
Our Spring
Sale
April 1, 2, 3

Huge Discounts
on all in
stock granite
and marble tiles

Undermount Stainless
Steel Sinks 18 Gauge
only \$229⁹⁵

Ceramic Tile Sales Inc. Marble & Granite Shop

Southfield
23455 Telegraph Rd.
(248) 356-6430

Farmington Hills
24301 Indoplex Circle
(248) 426-0093

Visit one of our Showrooms!

Installation includes Wayne, Oakland, and Macomb Counties. Others at additional cost. Offer not valid with any other discount. All previous orders excluded. Subject to stock on hand.

Southfield/Farmington Hills Hours: M-T-Th 8:30-5:00; W-F 8:30-8:00; Sat 9:00-5:00

SHOP HERE LAST, WE WILL BE YOUR BEST DEAL!

THE MOST POWERFUL FORM OF CHECKING KNOWN TO MONEY.



Free One Checking, with Direct Deposit

Over 4,300 free Bank One ATMs

Free customized E-mail Alerts that can save you money

Simple and free Online Bill Pay

BANK ONE.

ORCHIDS

FROM PAGE C1

20-25 displays with thousands of flowers at the MOS show, along with 12 vendors selling orchids

Burton, MOS president, said orchids are relatively easy to grow. "And they are so pretty to grow," Burton said.

"I used to kill houseplants," Burton added, "but I've been growing orchids for about 12 years." She enjoyed their beauty when she was volunteering at Cranbrook as a master gardener. "A lot of them bloom between January and May. This seems to be the best time of year for them."

The moth orchids or Phalaenopsis bloom from late winter to spring, and are popular gifts for Easter and Mother's Day.

Burton likes growing the Phalaenopsis, Paphiopedilum and Phragmepedium in her two greenhouses in White Lake.

"(Orchids) like to grow in bark," Burton said. "Most people tend to overwater them. They usually only need water once every five to seven days, depending on how dry the air in the house is."

Wagner of Farmington Hills is a judge for the American Orchid Society and will be a judge at the show. Orchids are judged on various requirements, uniqueness and beauty.

"You look for quality flowers," Wagner said. Some of them have certain marks and you give them points for quality and clarity. Learning to judge takes several years of learning quality and balance.

Orchid displays must show a flower that's not been displayed before. "You have to know that what you show has not been shown before," Wagner said. "Something that's been shown in Japan will be put on the Web site. I have to beat what's been shown."

The Web site is updated every two weeks. Thousands of plants will be displayed at the Livonia show and many will win ribbons from the MOS, but only one or two will win from the AOS. "It has to be better than everything that's been shown in the world," Wagner said.

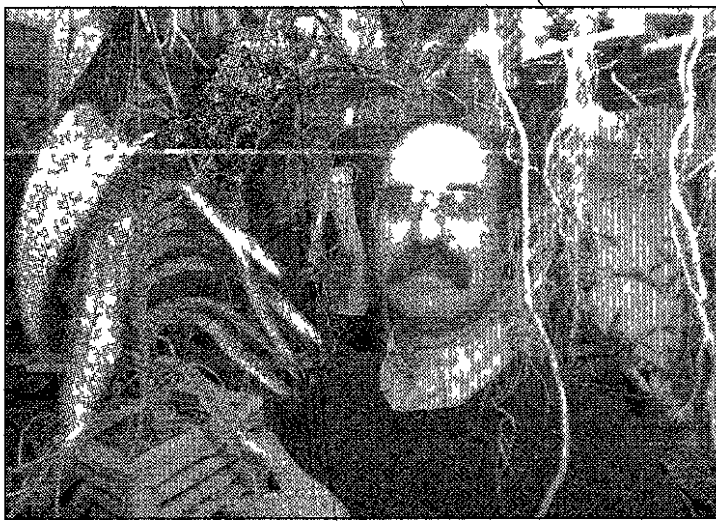

Peterson displays another blooming orchid inside his greenhouse



Easter themes blossom in early April

Good plant health is important when choosing orchids to grow, Wagner said. Good plant health and robust plants are controlled by the environment and genes, he said. It's like good artwork, it's in the eyes of the beholder.

Wagner started 30 years ago with orchids. "I liked them, I liked growing them, and I liked the people I met who grew them," he said. It's taken me all over the world. I've been on the Amazon, in Africa and Asia.

Peterson loves the plants. "I think they're kind of exotic in nature, they're just wild looking compared to what you usually see around here. It's a challenge to grow."

Growing orchids require, like most plants, watering consistency.

"I don't consider them hard to grow," Peterson said. "When you talk to someone about why their orchids died, you find out that they forgot to water them. But most of them are not hard

to grow. Many of those orchids found at local nurseries, such as English Gardens or Bordines, are among those that are easy to grow. And you don't need a greenhouse, either.

Most people start on a window sill, Peterson said. Fir bark is used, not soil. Some grow in trees. "You put them in bark, water once a week and fertilize occasionally," he said.

Peterson also will judge the orchid displays. Judges look for balance, contrast and proportion along with other characteristics. "Judges look at do the colors flow together, or are they all mishmashed together," he said. "You want something in a prominent part of the display, and your eye is drawn to it."

Peterson said the two most important criteria are general arrangement and quality of flower.

General arrangement is the overall design of the display," Peterson said. "We are looking at how well the display handles balance, contrast, dominance, proportion, rhythm and scale based on principle of design."

Quality of flowers is equally important. We are looking at how the flowers are presented, form, fullness and color of the flowers (general rule of thumb, differs by type of orchid), and number of flowers. Two other criteria that are used to a lesser degree are variety of flowers in the display and labeling.

Peterson still has the first orchid he purchased at Tel-Twelve Mall. It's 18 years old and I've divided it six times, he said. "These plants will live forever."

BE PART OF OUR FIRST ANNUAL
Senior Citizens Expo
 "CELEBRATING SENIOR LIFE IN AMERICA"

Wednesday, May 19, 2004
 10 a.m. - 2:30 p.m.
SCHOOLCRAFT COLLEGE
 Livonia Campus - VisTaTech Center

presented by
THE Observer & Eccentric
 NEWSPAPERS
 WWW.HOMETOWNLIFE.COM

and
Schoolcraft College
 WWW.SCHOOLCRAFT.EDU
INCREASE YOUR SENIOR CLIENT BASE — PARTICIPATE IN THIS PREMIER EXHIBITION!

Your Senior Expo Exhibitor Package Includes:

PROMOTION: Signs at Schoolcraft College and advertisements in the 15 Observer & Eccentric Newspapers and four HomeTown Newspapers prior to the event

BOOTH SPACE: A covered table with 2 chairs, a table card identifying your business and two box lunches prepared by Schoolcraft College's culinary arts department

QUARTER PAGE AD: Your ad will appear in more than 200,000 newspapers, all 15 Observer & Eccentric Newspapers and four HomeTown Newspapers. An additional 5,000 guides will be distributed during the event. Your business name will also be listed on the floor plan in the Senior Expo Guide.

Reserve your booth today, call
1-800-579-7355

OE08197662 EPS

Spring Shower of Savings



Offering 3 Ways To Afford The Furniture You've Always Wanted!

1

Pay Cash And Receive An Extra 8% Discount**

2

SIX MONTHS Deferred Payment

3

We Will Pay Your 6% Sales Tax

- Bob Timberlake
- Bradington Young
- Hooker
- King Hickory
- Dinaire
- Canal Dover
- Thomasville
- Nichols & Stone
- Charleston Forge
- Howard Miller
- I.M. David
- Harden
- Butler
- Lexington
- Hekman
- Sligh
- Restonic
- Superior
- Durham
- Custom Shoppe
- Sherrill

Hurry... Sale Ends April 10th, 2004

VISIT OUR IN-STORE CLEARANCE CENTER

CLASSIC INTERIORS FURNITURE

Store Hours:
 Mon., Thurs., Fri. 9:30-9:00
 Tues., Wed., Sat. 9:30-5:30
 Open Sunday 1-5



20292 MIDDLEBELT, LIVONIA • South of 8 Mile • 248-474-6900

*Some selected Thomasville pieces not included • All discounts are off manufacturers suggested retail price • All previous sales excluded • Offer not valid with any other promotional offer

Garden centers to offer soil testing service

The Michigan State University soil nutrient testing service will be offered by participating garden centers from Saturday, April 3, through Sunday, April 25.

Test results will be returned in time for spring planting.

The service is offered in cooperation with the Southeastern Oakland County Water Authority (SOCWA) and the Groundwater Stewardship Program, Oakland County MSU Extension. A soil test shows you the needs of your garden or lawn. It indicates nutrient levels already in the soil — a first step in determining how much and what type of fertilizer is needed for the plants you are trying to grow.

The cost is \$13 per sample, which includes an analysis of nutrients, organic matter and pH, and delivery of the sample from the retailer to the MSU laboratory.

Organic matter should comprise 5 percent or more of the soil by weight (5 to 10 percent by volume). Organic matter needs to be periodically replaced because it is continually "used" in a biologically active soil system. Compost and peat are examples of organic matter materials that improve soil structure, retain water, encourage root penetration and aerate soil.

Soil test boxes may be bought from the retailers or from the Oakland or Wayne

County MSU Extension. Retailers in Oakland County participating in the soil testing service are Bordine Nursery in Clarkston and Rochester Hills, Oxford Farm/Garden Center in Oxford, Auburn Oaks Nursery in Rochester Hills, Telly's Greenhouse and Garden Center, and Uncle Luke's Feed Store, in Troy, English Gardens (all locations), Glenda's Garden Center in Novi, Four Seasons Garden Center in Oak Park, and Goldner Walsh Nursery in Pontiac.

Participating retailers in Wayne County are Plymouth Nursery in Plymouth, Barson's Greenhouse, Clyde Smith Nursery, and Panetta Landscaping in Westland, Tom's Lawn and Garden Center in Allen Park, and Ray Hunter Flowers in Southgate.

The retailers will complete the testing form and box your sample for analysis at the MSU soil testing laboratory.

Retailers, in cooperation with public agencies, will deliver the soil test boxes to the lab. After the analysis, the report will be mailed to you.

For soil nutrient testing throughout the year, call the Oakland County MSU Extension at (248) 858-0902 or the Wayne County MSU Extension at (313) 833-3412.

For more information, call SOCWA at (248) 288-5150 or visit www.socwa.org.

Here's the 'recipe' for natural egg colorant

Botanical colorants, made from natural herbs and plants, are a non-toxic alternative to packaged chemical dyes, says Lesley Chace of the Evening Herb Study Group of the Friends of the University of Michigan Matthaei Botanical Gardens.

Colors that correspond with the plants are:

- purple/burgundy — grape juice, blueberries, alkanet root
- brown — coffee, tea
- orange — yellow onion skins, paprika
- blue — red cabbage, indigo
- green — spinach, spirulina
- red/pink — beets, madder root
- gold — chamomile
- yellow — turmeric, annatto, calendula

You'll need a stainless steel or enamel pot large enough to hold the plant material and a

quart of water, white vinegar, a wire egg dipper" (easy to fashion out of plain wire) or a slotted spoon, and wide-mouth glass jars or ceramic cups large enough to hold as many eggs as you want to color along with the liquid to cover them (peanut butter and jam jars or coffee mugs work well).

"One thing to keep in mind when using botanical colorants is that most of them will not produce instant results, and some take as long as 24 hours to really work," Chace said. "It's a good idea to plan ahead!"

The ground roots and spices are an exception, as they take only a few seconds to a couple of minutes for their color to stick, she said.

The eggs don't have to be treated beforehand, although it is a good idea to wash them using dish soap, warm water and a soft brush, Chace said.

Runse and dry them thoroughly before coloring.

Be mindful that eggs shouldn't be out of the refrigerator for more than a few minutes, cooked or uncooked, Chace said.

Making the colorants basically involves boiling the plant material in water for at least 20 minutes and then turning off the heat and letting it steep until lukewarm to cool, she said.

Chace provided the following directions:

The amount of plant material depends on the material. It takes about 2 cups packed chopped cabbage or spinach, 1 cup chamomile flowers or blueberries, or a tablespoon of the powdered spices or roots, to 1 quart water.

Once boiled, strain off the liquid, and add 2 tablespoons white vinegar to each quart of

liquid (1 tablespoon to a pint of liquid, or 1 scant teaspoon to a cup). Some of the colorants will work without the addition of vinegar, but vinegar generally acts as a fixative.

The colorants can be used cold by boiling the eggs first, and then immersing them in the liquid colorant and refrigerating them for several hours or overnight.

If you want to add designs, you can use egg white as a glue to stick small leaves, string or other appliques on the egg before immersing in the cold colorant.

Another method is to boil the eggs in the colorant.

Place the eggs in a single layer in the pot, cover with cooled liquid colorant, bring to a boil and let boil for 15 to 20 minutes.

Don't put cold eggs in hot liquid, or they may crack.

EGGS

FROM PAGE C1

flame so the wax will melt. Use a tissue to wipe the section clean of wax. Continue in this way until all of the wax is removed.

"If you get a drop of wax where you don't want it, you're stuck with it," Miley said. "For the first year, don't try to do anything too elaborate."

Instead of blowing the yolk and albumen out of the eggs, you can use raw eggs, Miley said. As long as the raw eggs are stored in a pressed cardboard — not Styrofoam — egg

carton, they will be able to "breathe" enough to dry out, she said.

This year, Latin and Orthodox Easter fall on same date (April 11).

Another way of decorating eggs is by using natural herbs and plants for coloring.

Lesley Chace, president of the Evening Herb Study Group of the Friends of the University of Michigan Matthaei

Botanical Gardens, will demonstrate this method at the group's meeting 7 p.m. Monday, April 5, at the Gardens, 1800 N. Dixboro Road in Ann Arbor. The public may attend.

Chace, of Ypsilanti, says that botanical colorants are a non-toxic alternative to packaged chemical dyes.

"Many of the plants that can be used to color eggs are inexpensive grocery items you would buy anyway, and some can even do double duty on the dinner plate and in the coloring cup," said Chace, a member of the Ypsilanti Garden Club.

There are other advantages, Chace said.

"Using botanical colorants also reminds us that nature brings us beauty in many ways. It gives us a chance to connect with everyday plants as creative helpers, and reminds us

Pysanky designs can have special meaning

According to the Web site of The Ukramian Gift Shop Inc. in Minnesota, among the symbols commonly used on pysanky today and what they represent are:

- rose or eight-pointed star — Christ
 - sun — life, warmth, love of God and the eternal existence of God
 - birds — fertility and fulfillment of wishes
 - pine needles — eternal life
 - diamonds — knowledge
- Colors and their meanings, according to the Web site, include:

- white — purity, light, rejoicing, virginity
- yellow — sun, stars, moon, harvest, warmth, perpetuation of the family
- orange — endurance, everlasting sun, ambition
- red — happiness, hope, passion, blood, fire, ministry of the church
- blue — sky, air, good health, truth, fidelity
- green — spring, breaking bondage, hope, freshness, wealth
- purple — royalty, faith, trust, patience, fasting

From www.ukrainiangiftshop.com

of our age-old relationship with plants," she said.

Of the plants that can be used for coloring, common ones that can be found in the grocery store are grape juice, blueberries, coffee, tea, onion skins (both yellow and red), red cabbage, spinach, beets, chamomile (an herbal tea — best if you can find it in bulk), and the spices turmeric and paprika.

Some of the plants that are harder to find — which would have to be harvested earlier or ordered from a supplier — are spirulina (a seaweed), indigo (a plant) and the herbs madder root, calendula, alkanet root

and annato.

Chace shared some cautionary advice. "Madder root has been somewhat controversial in recent research, because there is some evidence that suggests it could be carcinogenic if ingested in large quantities," she said. "If you have any concern about whether the inside of the egg has been affected during the coloring process, you probably should not eat it."

However, using any of these roots, flowers, fruit and leaves to create an infusion that is only used topically is not likely to pose any health risk.

Don't Compromise Customize!

Now you can have wall systems entertainment centers or bookcases custom built just for you. See over 40 entertainment centers and wall systems on display. All units can be sized to fit any wall, any TV and any sound system.

KITCHEN REFACING FREE ESTIMATES

- The Leader in Cabinet Refacing
- Factory Direct
- Much less than replacing
- Solid Oak Maple Cherry
- References in your neighborhood

SPRING SALE Now in Progress!

cabinet clinic

WEST (734) 421-8151
NORTH EAST (586) 751-1848

www.cabinetclinic.com

Too Late To... Classified

For those last minute ads that just had to get in!

<p>4000-4500 New Estate Call Chuck or Elena Option to buy (734) 641-0020</p>	<p>5000-5900 Employment Help Wanted-General Call Keith or Peter after 11am 248-478-8600</p>	<p>7000-7700 Merchandise FOUND DOG Black Schnoodle Poodle Henry Ruff & Warrner Ave n Gardner City on Sat (734) 421-0135</p>
<p>4000-4500 Condos/Townhouses BRIGHTON 5 Bed 3200 sq ft 2 kitchens 3 full baths in shed mother in law apartment in walk out bsmt. Available April. Call Chuck or Elena Option to buy (734) 641-0020</p>	<p>5000-5900 Help Wanted-General CALL CENTER REPS Farmington Hills Home Improvement Co. s hiring appoliment setters. Full Time 12:30 8pm Mon-Fri Sat 10:30m & Part Time Mon-Fri 10:2 \$8-\$10 per hr plus bonus. Professional atti- tude team player des re to maximize income & utilize saas skills. Call Keith or Peter after 11am 248-478-8600</p>	<p>7000-7700 Merchandise Automotive 14 ft aluminum boat 1998 15hp Evinrude OB Shore lander trailer Excellent con- dition \$1600 734-459-8381</p>
<p>4000-4500 Office/Retail Space For Rent/Lease NORTHVILLE Off ce Space/ Downtown upper unit 1.2 room space w/kitchen area and conference area \$375 per month per room 1 yr lease only. Available May 1st Storage space available in basement. Located at 410 S. Main St Northville Rd. Call Terri a 248 347 4350 or 734 667 2382</p>	<p>5000-5900 Help Wanted-General SIGN SHOP Some exp in vinyl / wood / paint / install. Fax info to 313 331 8861</p>	<p>7000-7700 Merchandise Boats/Motors 14 ft aluminum boat 1998 15hp Evinrude OB Shore lander trailer Excellent con- dition \$1600 734-459-8381</p>
<p>4000-4500 Condos/Townhouses White Lake Condo New con- struction 2 bed townhouse 1500 sq ft 2.5 baths full bsmt all appliances incl washer/dryer 2 car attached garage deck Walled lake schools \$1400 mo 248 932 0550 248 626 6264</p>	<p>5000-5900 Help Wanted-General STOCK PERSON (FULL TIME) Lighting showroom Benefits good working conditions Experience preferred Apply in person BROSE ELECTRICAL 7 Mile & Newburgh Livon a 734 464 2211</p>	<p>7000-7700 Merchandise Boats/Motors BOAT ALUMINUM 14 ft 15 HP engine trailer exec cond \$1200 SOLD</p>

Manufacturers Close Out SALE

From \$1.23 sq. ft. installed
NO PAYMENTS FOR ONE YEAR!

FLOOR COVERING plus Over 50 Years Experience
Call Now! 313-381-8003

COMMERCIAL & RESIDENTIAL FLOOR COVERINGS
The Plus Is Customer Satisfaction

BEST INVESTMENT WE EVER MADE

We hear that a lot. Lennox High Efficiency Furnaces save you money, sometimes as much as 40% over your old furnace.

CALL TODAY & START SAVING!
248-489-8180 313-537-8111

Airtronic Heating & Cooling
FREE ESTIMATES
LENNOX

There's nothing better than being "front row center" in your own home theater. Our Cinema Collection is ideal for TV and movie viewing with generous proportions, plush cushions and a look that's just what the script called for. Choose fabric or leather with manual or power reclining units.

Wm. C. Franks FURNITURE

2945 S. Wayne Road • Wayne
(4 Blocks N. of Michigan Ave.)
734-721-1044

Store Hours:
Mon., Thurs., Fri. 9-9
Tues., Wed., Sat. 9-6

\$4.5 Billion to winners!

Ten years of action, ten years of winning, and ten years of being the area's best!

10 Years of Fun! 1994-2004
Play today, there's more to come!

Know Your Limit, Play Within It! 1-888-230-3505 Ontario Problem Gambling HelpLine. Must be 19 years of age or older. www.casinoswindsor.com *Since 1994.

CASINO WINDSOR

How to check thermal fuses, clean shirt stains

John writes - "I talked to you this afternoon about my gas dryer. The igniter was good, jumped the thermal fuse and the flame kicked on. Picking up a fuse tomorrow."



Appliance Doctor

Joe Gagnon

Thanks for your help again. This is the third time you walked me through an appliance problem."

Do you know, John, that I've been writing this column for so long that I am starting to get mail and calls from grandchildren of readers? It's my privilege in life to be able to help others.

The little thermal fuse you are replacing was added by some manufacturers about 10 years ago to prevent a clothes dryer from catching fire in cases where the vent line is not correct. Anything that restricts or slows the air leaving the dryer to the outside will cause this fuse to blow. This all came about because clothes dryers are responsible for over 15,000 house fires a year in this country. Clothes dryers never had a safety device installed on them.

I'm sure this fuse has prevented many tragedies from happening. Had this old appliance doctor been asked to engineer the addition of this thermal fuse, I would have placed it somewhere on the dryer where the homeowner could change it themselves. As it stands now, you have to take the back panel off the dryer and you will see this plastic tear-drop fuse with two wires leading to it. You can by pass it by hooking the two wires together. If the dryer heats up, bingo, you found the problem.

The fact remains that the industry has created a lot of work for technicians across America by placing it on the back and it is such a simple repair. I had a homeowner not long ago tell me that he spent \$176 to have a service company come out and change this fuse. Still, I think it's great that manufacturers of clothes dryers are working to decrease the amount of fires caused by their products.

WHITES GET YELLOW

Gary writes - "Every time I wash whites they come out with yellowish spots. It's a General Electric washer that's 15 years old."

Reply - There are a lot of people reading this column today who can relate to your problem, Gary. I started changing GE transmissions way back in the mid-'60s for consumers with your exact problem. The top seal on the transmission gives way and lets oil creep inside the tub. It is not a problem that should be fixed by most do-it-yourselfers. That is why companies once sprang up to do nothing but rebuild transmissions. Many of these are gone now because GE redesigned their transmissions some 10 years ago.

The oil spots on the clothes can usually be removed by letting the items pre-soak in a mixture of water and a pint of white vinegar.

TANG RECIPE

Note: The Tang treatment for the dishwasher that so many have called me about deserves repeating. Purchase a 16-ounce container of the orange Tang powdered breakfast drink. Turn on the hot water faucet at the sink for a few minutes until the water is at maximum temperature. Shut off the faucet and turn on the dishwasher, empty of any dishes. Let it run for 6 minutes, and shut it off and open the door. Deposit the contents of the Tang jar into the bottom of the dishwasher, shut the door and let it go through a complete cycle. You now have a clean dishwasher. Stay tuned.

Joe Gagnon can now be heard on WWJ 950 and WXYT 1270. He is a member and past president of the Society of Consumer Affairs Professionals. His phone number is (248) 455-7281.

MBH Garden Club

The Meadow Brook Hall Garden Club will meet 10 a.m. Friday, March 26 in the Coach House adjacent to Meadow Brook Hall on the Oakland University campus in Rochester. Guest speaker Robert McGowan of Bittersweet Farm in Clarkston will lecture on Large scale Vegetable Gardening: The Organic Way. Guests are welcome. Non-member donation \$5. Reservations are not required.

Detroit Rose Society

The Detroit Rose Society will have a general meeting 7:30 p.m. Friday

March 26 at the Pleasant Ridge Community Center on Ridge Road one block south of I-696 and one block west of Woodward Avenue. Consulting rosarian Gerry Carney, past president of the Detroit Rose Society, will present a slide tour of his garden. A short demonstration on spring pruning will also be featured.

Chimes and vines

Telly's Greenhouse & Garden Center 3301 John R in Troy has scheduled classes and other events. The offerings include two events taking place 10 a.m. Saturday, March 27: Copper and Quartz Wind Chime

GARDEN CALENDAR

Workshop and a presentation: New and Underused Hardy Vines. In the workshop, Jeane Houston will help you make your own beautiful copper wind chimes with natural agate quartz crystals and decorative marbles. Fee is \$30. All materials and tools will be provided. In the presentation, guest speaker Drew Edwards will discuss dozens of perennial vines for adding vertical color to your fence, arbor, wall, trellis or obelisk. Through slides and handouts, attendees will learn what plants will work for their gardens. Call (248) 689-8735 for information.

Garden renovation

The Community House 380 S. Bates in Birmingham will offer a class: Renovating a Garden. Saturday, March 27. The fee is \$69. Most gardeners inherit at least one previously planted area. Instructor Gail Dudzinski, a master gardener, will teach you how to make changes and express yourself while maintaining unity between new and old. Come prepared to travel to a garden that needs renovating. Dress appropriately to the weather: rain or shine, and bring your lunch.

The class will cover what to keep, how to visualize changes, designing around existing features, transplanting and soil improvement techniques, tips toward phasing in the changes, and suggested plants. Dudzinski formed her own garden maintenance firm in 1991 and for 10 years has served as the head gardener for several estates in Bloomfield Hills. She has been an instructor for the Michigan School of Gardening since 1999. To register, call The Community House at (244) 644-5832 or visit www.communityhouse.com.

LOWE'S Supplying the Pros Since 1946

Improving Home Improvement

4 DAYS ONLY
March 25 - March 28

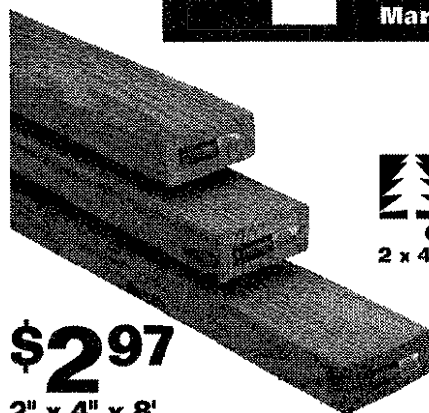

\$2.97

2" x 4" x 8'

Treated Top Choice®

- #2 prime grade mark • 4 square edges • Less bark
- Straighter & smoother • Fewer defects • Less wasted wood #46905

TOP CHOICE LUMBER PRODUCTS
Our best quality
2 x 4 x 8 Treated Lumber

Only at Lowe's!

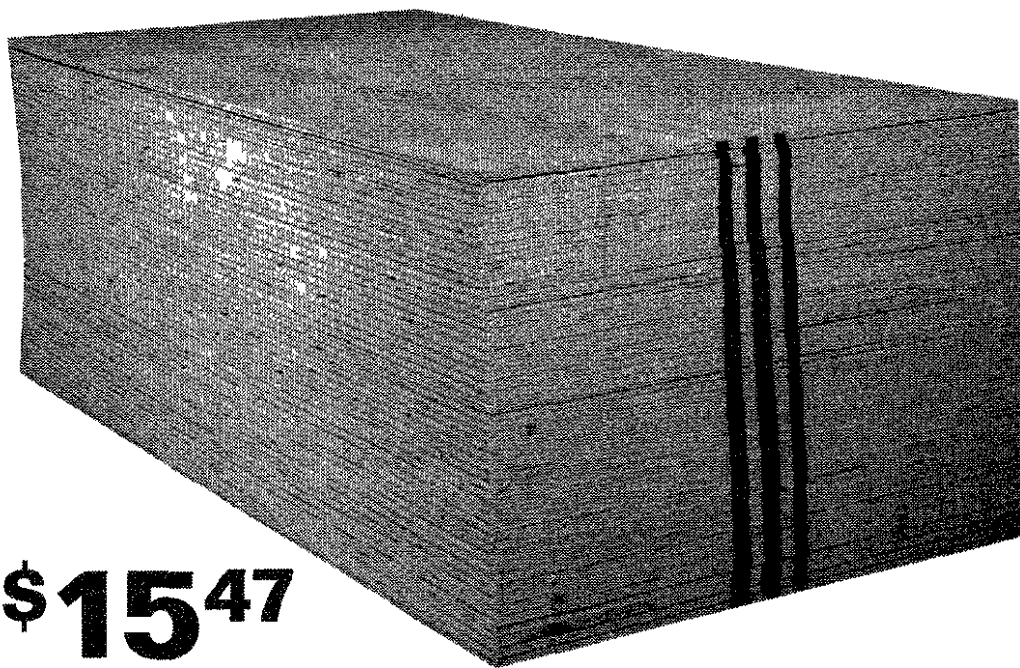

\$15.47

1 1/2" x 4' x 8' 3 Ply Sheathing Plywood

- Use for roofs, walls, subfloors when used under underlayment • Construction grade panels #12192

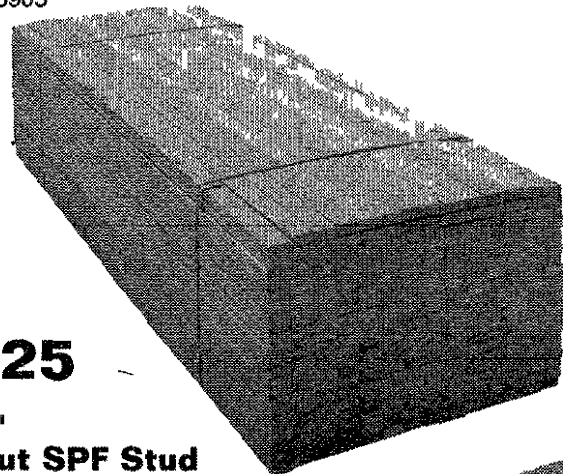

\$2.25

2" x 4"

Pre-Cut SPF Stud

- Precision end trimmed • Lightweight
- Straight • Easy to cut and nail • 4 sides surfaced • For interior use #06003 7020 7021

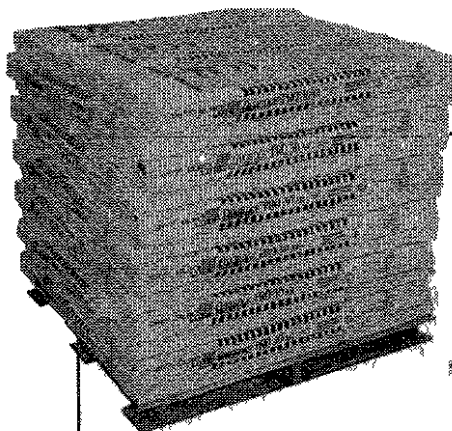

\$13.98

30 Year Architectural Shingles

- Tough, laminated construction
- Enhances curb appeal
- UL Class A fire and wind resistance rating

FREE DELIVERY

With purchase of \$350 of Owens Corning Shingles (does not include 20 yr. classic and accessories). Via main rebate. See store for details.

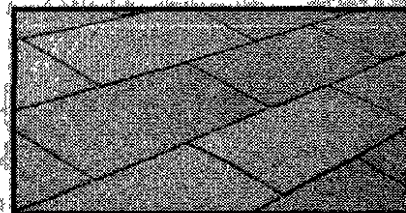
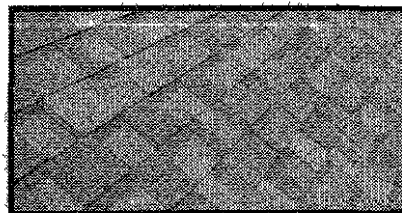

\$10.43

25-Year 3-Tab Shingles

- 33 1/2 sq. ft. per bundle
- Class A fire and wind rating
- Premium 3-Tab
- Quality appearances



\$4.95

50 lb

Fast-Setting Concrete Mix

- Sets hard in approximately 20 40 minutes without mixing • Achieves 4000 psi
- Excellent for setting deck and fence posts • Meets ASTM C387 #10437

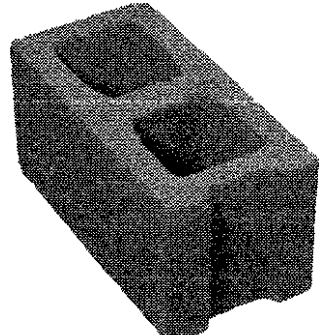

99¢

8" x 8" x 16"

Concrete Block

- Sturdy, all purpose building block use for a variety of projects
- Great for building foundations, retaining walls, etc • Job lot quantities available #10383

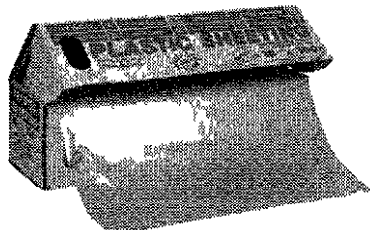

10' x 100'

Plastic Sheeting

\$10.97

- Use as vapor barrier • 2 mil thickness #16903



4" x 10' Solid

Corrugated Pipe

25¢ per ft.

- For outdoor drainage #24134

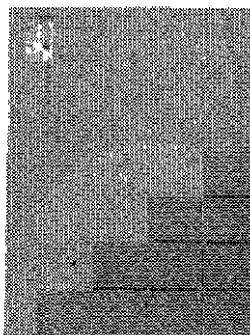

\$7.98

3' x 5', 1/4" Hardibacker® Board

- Resists damage caused by steam and water #11640

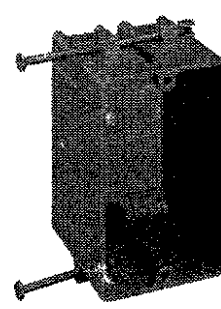

18¢

18 Cu. In. New Work Electrical Box

- Blue • Single gang • Non metallic construction #70972

\$99

32" or 36" 6 Panel Steel Entry Door Unit

- Magnetic weatherstripping
- Primed
- Ready to install door with frame • Limited lifetime warranty
- Lockset sold separately
- Ready for lock set and deadbolt #21681, 2, 3, 4

\$19 YOUR CHOICE

24", 28", 30", 32" or 36" 6-Panel Molded Interior Door Slab

- 1 1/2" thick molded construction
- Primed and ready to paint
- Lockset sold separately
- Finished opening 80 Height #10973 4, 5, 6, 7

\$298

6' 30 Series Vinyl Sliding Patio Door Unit

- Maintenance free • Insulating glass for energy efficiency • Fully weatherstripped for a tight seal
- Limited lifetime warranty • Fully assembled frame and ready to install • Handleset included • Rough opening 72"W x 80"H #59373

Only 28¢ per sq. ft.

2' x 4' Impressions Ceiling Panel

- 48 W • Class A fire retardant • 10 year limited warranty • 64 sq. ft. per carton #12355

Chesterfield 27990 23 Mile Rd (586) 948-0854 Monday-Saturday 8am-10pm Sunday 8am-6pm	Warren 31140 Van Dyke (586) 826-7661 Monday-Saturday 8am-10pm Sunday 8am-6pm	Clinton Twp. 15390 Hall Rd (586) 416-2534 Monday-Saturday 8am-10pm Sunday 8am-6pm	Bloomfield 1801 South Telegraph Rd (248) 338-2366 Monday-Saturday 8am-10pm Sunday 8am-6pm	Howell 1100 S. Latson (517) 848-3475 Monday-Saturday 8am-10pm Sunday 8am-6pm	Monroe Fronchtown Twp 2191 North Telegraph (734) 384-8478 Monday-Saturday 8am-10pm Sunday 8am-6pm	Westland 6555 Newburgh (734) 728-8620 Monday-Saturday 8am-10pm Sunday 8am-6pm	Southgate 3/4 Mile S of Eureka Rd on Trenon Rd. (734) 284-8843 Monday-Saturday 8am-10pm Sunday 8am-6pm	Harper Woods 19340 Vernier Rd Harper Woods (313) 881-6002 Monday-Saturday 8am-10pm Sunday 8am-6pm	S. Clinton Twp. 38115 S. Gratiot Clinton Twp (586) 738-3000 Monday-Saturday 8am-10pm Sunday 8am-6pm
---	---	--	--	---	---	--	--	---	---

Prices may vary after March 28 2004 if there are market variations. See store for details regarding product warranties. We reserve the right to limit quantities.

Your Invitation To Worship

Mail Copy To:
Observer & Eccentric Newspapers
36251 Schoolcraft, Livonia MI 48150
Or Fax: (734) 953-2232

For Church Page Changes And Information Regarding Advertising In
This Directory, Please Call: Jean Etherington (734) 953-2160
THE FRIDAY BEFORE PUBLICATION

ASSEMBLIES OF GOD

You Are Welcome At
Tri-City Christian Center
3855 Sheldon Rd Canton (Just N of Michigan Ave)
734-397-1777 • www.Tri-City-Christian.org

Come Join Us

Worship Service & Children's Ministries Sunday 9:00am & 11:00am
Youth Service Wednesday 7:00pm
Family Night Wednesday 7:00pm

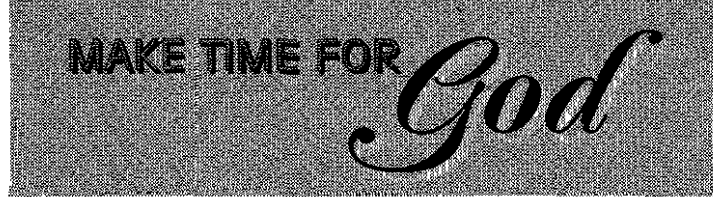

BAPTIST

NEW HOPE BAPTIST CHURCH
33640 Michigan Ave • Wayne MI
(Between Wayne Rd & Merriman Rd)
(734) 728-2180
Virgil Humes, Pastor

Sunday Evening Worship 6:00 p.m.
Sunday Worship 7:45 a.m. and 10:45 a.m. • Sunday School 9:30 a.m.
Wednesday Pray Serv 6:00 p.m. • Wednesday Ch. Ltrn. Youth and Ad. 1 Bible Study 7:00-8:00 p.m.

Canton Christian Fellowship
"Where the Word is Relevant,
People are Loved and Christ is the Key"
Join us for Worship Service at 10:30am
Sunday School and/or New Members Orientation 9:00am
Located at 6500 N Wayne Rd • Westland MI
Inside Good Shepherd Church
734-721-9322

It's not about Religion, it's about Relationships
Come to a place where lives are changed, families are made whole and ministry is real!

CATHOLIC

ST ANNE'S ROMAN CATHOLIC CHURCH
Traditional Latin Mass
St Anne's Academy - Grades K-8
23310 Joy Road • Redford Michigan
5 Blocks E of Telegraph • (313) 534-2121

Mass Schedule

First	Fri	7:00 p.m.
First	Sat	9:30 a.m.
Sun	Masses	7:30 & 9:30 a.m.

Confessions Heard Prior to Each Mass
Mother of Perpetual Help Devotions
Tuesdays at 7:00 P.M.

RESURRECTION CATHOLIC CHURCH
48755 Warren Rd Canton Mich 48187
451-0444
REV RICHARD A. PERFETTO

Weekday Masses
Tuesday & Friday 8:30 a.m.
Saturday - 4:30 p.m.
Sunday - 8:30 & 10:30 a.m.

ST GENEVIEVE ROMAN CATHOLIC CHURCH & SCHOOL
29015 Jamison Ave • Livonia
East of Middlebelt between 5 Mile & Schoolcraft Rds
MASS: Mon, Wed, Thurs, Fri 9:00 a.m.
Tues 7:00 p.m. • Sat 5:00 p.m.
Sun 8:30 & 10:00 a.m. & 12:00 noon
Confessions Sat 3:00-4:00 p.m.
734-427-5220

CHURCH OF CHRIST

CHURCH OF CHRIST WEST
291 East Spring Street • Plymouth 48170

Sunday Worship • 11am & 6pm
Bible Class
Sunday 10am & Wednesday 7pm

734-431-1877
Minister: Michigan Bible School
John Natow Tuesday & Thursday 7pm
www.churchofchristwest.org

CHURCH OF GOD

Riverside Park Church of God
11771 Newburgh Road
Livonia
Come to Plymouth and Newburgh
734-464-0890

Service Schedule:

Sunday School	9:30am
Sunday Worship	10:45am
Sunday Evening	6:30pm

The Purpose Driven Life • Wednesday 6 at 7:00pm
Children Provided

CHRISTIAN SCIENCE

First Church of Christ Scientist, Plymouth
1100 W Ann Arbor Trail, Plymouth, MI
734 453-0970

Sunday Service 10:30 a.m.
Sunday School 10:30 a.m.
Wed Evening Testimony Meeting 7:30 p.m.
Read ng Room 550 South Main
Monday Saturday 11:00 a.m. 1:00 p.m.
734 453-1676

CHURCHES OF THE NAZARENE

PLYMOUTH CHURCH OF THE NAZARENE
45801 W Ann Arbor Road • (734) 453-1525

Sunday School 9:45 A.M.
Sunday Worship 11:00 A.M.
Sunday Evening 6:00 P.M.
Family Night Wed 7:00 P.M.

NEW HORIZONS FOR CHILDREN 455 3199

CONGREGATIONAL

Mt. Hope Congregational Church
50350 Schoolcraft Livonia • 734 425 7280
(Between Middlebelt & Merriman)

9:30 a.m. Sunday School
10:30 a.m. Worship Service

Nursery Care Available
Bible Class
"The Church You've Always Longed For"



EVANGELICAL LUTHERAN CHURCH IN AMERICA

Timothy Lutheran Church
8820 Wayne Rd
(Between Ann Arbor Trail & Joy Road)
Livonia • 427-2290
Sandra Daily Pastor

9:00 a.m. Sunday School (all ages)
10:00 a.m. Family Worship (Nursery Avail)
http://www.timothylivonia.com

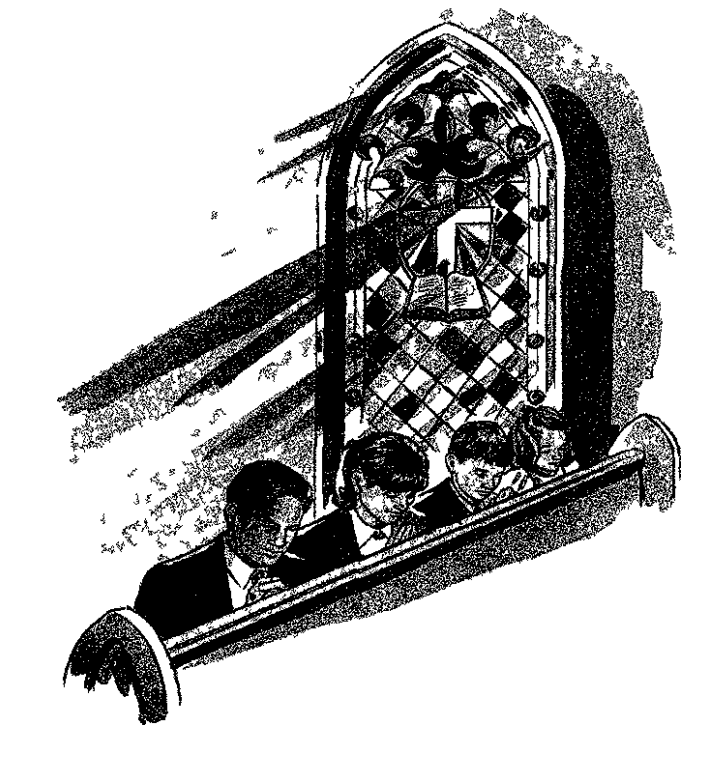

UNITED METHODIST

Clarencville United Methodist
20300 Middlebelt Rd • Livonia
474-3444
Pastor James E Britz

Worship Services 8:45 & 11:15 AM
Sunday Eve Bible Study 6:00 PM
Nursery Provided
Sunday School 10 AM

RICE UNITED METHODIST
20601 Beech Daly
Redford MI 48240
Reverend Gregory Rows

Sunday Worship at 11:15am
Children's Church at 11:30am
313-534-4907

"More than Sunday Services"
9:00 and 11:00 a.m. Worship Service

- Dynamic Youth and Children's Programs
- Excellent Music Ministries
- Small Groups For Every Age
- Outreach Opportunities

Pastors
Dr. Dean Klump Rev. Deborah Thomas

ST. MATTHEW'S UNITED METHODIST
30900 S X Mile Rd (Bet Merriman & Middlebelt)
Rev. Mary Margaret Eckhardt, Pastor

10:00 A.M. Worship & Church School

www.gogm.umc.org/stmatthewsLivonia
Nursery Provided • 734-422-6038

First United Methodist Church of Plymouth
45201 North Territorial Road
(West of Sheldon Road)
(734) 453-5280
www.ptumc.org

NEWBURG UNITED METHODIST CHURCH
Stephen Ministry Congregation
36500 Ann Arbor Trail
between Wayne & Newburgh Rds
734-422-0149

Worship Service and Sunday School
9:15 a.m. & 11:00 a.m.

Rev. Terry W. Allen
Rev. Barbara E. Welbaum

visit our website www.newburgumc.org

Catch the Spirit of *Adersgate*
United Methodist Church
10000 Beech Daly Redford
Between Plymouth and W Chicago
Bob & Diana Goudie, Co-Pastors
313-937-3170

WORSHIP SCHEDULE

8:00 a.m.
Small and Cozy Worship
9:30 a.m. Worship Geared Toward Families With Children
11:00 a.m. Traditional Worship
Handicap Accessible

MINISTRY:
You were shaped for God's service.

GENEVA PRESBYTERIAN CHURCH (U.S.A.)
5835 Sheldon Rd, Canton
(734) 459-0013

Sunday Worship & Sunday School
9:00 a.m. & 11:00 a.m.
July & August 10:00 a.m.
Education For All Ages

Childcare Provided • Handicapped Accessible
Resources for Hearing and Sight Impaired
www.genevachurch.org

UNITED CHURCH OF CHRIST

NATIVITY UNITED CHURCH OF CHRIST
9435 Henry Ruff at West Chicago
Livonia 48150 • 421-5406
Rev. Larry Hoxey Pastor

10:30 a.m. Worship Service and Youth Classes
Nursery Care Available
WELCOME.

PRESBYTERIAN (U.S.A.)

FIRST PRESBYTERIAN CHURCH
Main & Church • (734) 453-6464

PLYMOUTH WORSHIP SERVICES
8:30, 9:30 & 11:00 a.m.

Dr. James Skimms Senior Minister
Rev. Richard Jones Associate Minister
Accessible to All
Rev. Mary Jean Bird Associate Minister

NON-DENOMINATIONAL

BELL CREEK COMMUNITY CHURCH
Casual, Contemporary, Excellent Children's Program

Meets at Franklin H S in Livonia on Joy Road
(Between Merriman and Middlebelt Roads)
at 10:00 a.m.
734 425 1174
Join us for coffee, bagels and donuts after the service!

ST. TIMOTHY PRESBYTERIAN CHURCH, USA
16700 Newburgh Road Livonia • (734) 464-8844

Sunday School for all ages 9:30 a.m.
Sunday Worship 11:00 a.m.
http://www.StTimothyPCUSA.org
Rev Janet Nob e Richardson Pastor

Rosedale Gardens Presbyterian Church (USA)
9601 Hubbard at W Chicago Livonia MI
(between Merriman & Farmington Rds)
(734) 422-0494

Contemporary Service 9:00 am
Traditional Service 10:30 am
Nursery Care Provided

We Welcome You To A Full Program Church
Rev Richard Peters Pastor
Rev Kell e Bohman Assoc ate Pastor

LUTHERAN CHURCH MISSOURI SYNOD

Christ Our Savior Lutheran Church
Rev Luther A Werth Senior Pastor
Rev Robert Bayer Assistant Pastor

With Jesus Christ love really can be all it was meant to be!

Sunday Worship 8:30 am & 11:00 am
Sunday School at 9:45 am

Staffed Nursery for young children every Sunday
734-522-6830

Early Childhood Center
Register now for Fall child care and preschool (734 513 8413)

Location
14175 Farmington Road (just north of I 96)
www.christsaviors.org

GRACE LUTHERAN CHURCH MISSOURI SYNOD
25630 GRAND RIVER at BEECH DALY
313-532 2265 REDFORD TWP

Worship Service
9:15 & 11:00 A.M.
Sunday School 9:15 & 11:00 A.M.
Nursery Provided

The Rev Timothy P Halboth Senior Pastor
The Rev. Dr Victor F Halboth Assistant Pastor

HOSANNA-TABOR LUTHERAN CHURCH & SCHOOL
9600 Leverne • So Redford • 313-937 2424
Rev Steve Eggers

Sunday Morning Worship 10:00 a.m.
Sunday School 9:00 a.m.
Adult Bible Class 9:00 a.m.
Chr st an School
Pre Kindergarten 6th Grade
For more information call 313 937 2233

Risen Christ Lutheran
46250 Ann Arbor Road • Plymouth
(1 Mile West of Sheldon) • 453 5252

Sunday Worship Service 8:15 a.m. & 10:45 a.m.
Sunday School (Adults & Children) 9:30 a.m.
LENTEN WORSHIP SCHEDULE
Wednesday, March 31st - 7:00 p.m.
Dinner provided 5:30 p.m.
All are Welcome! Come as you are!
Pastor David Martin

ST. MATTHEW LUTHERAN Church & School
1 Bk. N. of Ford Rd Westland 425-0260
5885 Veroy

Divine Worship 8 & 11:00 A.M.
Bible Class & SUNDAY SCHOOL 9:30 A.M.
Monday Evening Service 7:00 P.M.
Kurt E Lambert Pastor
Richard Schumacher Principal/Youth Director

SALEM LUTHERAN CHURCH
32430 Ann Arbor Trail • Westland MI
734 422-5550

Sunday Bible Study 9am
Sunday Worship Service 10am
Wednesday Evening Lenten Services 7pm

Rev David W Zeuschner Pastor

Grace Lutheran Church
Rev Kirk D Miller
46001 Warren Road just west of Canton Center
Sunday Worship at 9:30 am
Sunday School at 10:45 am
734-414-7422
Our mission at Grace Lutheran is to make teach and send out disciples who share Christ with all people



LUTHERAN CHURCH WISCONSIN SYNOD

ST PAUL'S EV LUTHERAN church & school
17810 Farmington Road • Livonia • (734) 261-1860
May thru October • Monday Night Service • 7:00 p.m.

Sunday Worship Services
8:30 a.m. & 11:00 a.m.
Pastor James Hoff
Pastor Eric Steinbrinner

EVANGELICAL COVENANT

FAITH COVENANT CHURCH
14 Mile Road and Drake Farmington Hills
(248) 661-9191

Sunday Worship and Children's Church
9:15 a.m. Contemporary
11:00 a.m. Traditional
Child Care provided for all services
Youth Groups • Adult Small Groups

EPISCOPAL

ST. ANDREW'S EPISCOPAL CHURCH
16360 Hubbard Road
Livonia, Michigan 48154
421-8451

Wednesday 9:30 A.M.
Wed (Sept-May) 9:00 PM
Saturday 5:00 PM
Sunday 7:45 & 10:00 A.M.
Sun (Sept-May) 10:00 A.M.
Sunday Morning Nursery Care Available
www.standrewschurch.net
The Rev C Allen Kannappell Rector

EVANGELICAL PRESBYTERIAN

WARD Evangelical Presbyterian Church
40000 Six Mile Road
"just west of I 275"
Northville, MI
248-374-7400

Dr. James N. McGuire, Pastor

Traditional Worship and Sunday School
8:00, 10:15, 11:30 A.M.
Contemporary Worship
9:05 A.M.
Nursery Provided During All Morning Worship Services
Evening Service • 7:00 P.M.
Services Broadcast 11:00 A.M. Sunday
WJUZ 560 AM

It's Easy To Criticize... Offering constructive criticism to others can be beneficial but only if the other person is receptive to our comments. In teaching situations or during on-the-job training, constructive criticism is usually necessary to instruct and help a person develop a trade or vocation. However, correcting someone, even in a kind or skillful manner, can be very challenging, since we are never sure how the individual may react. Many friendships and families have been destroyed because someone has been overly critical of another person's words or actions. Knowing when we should offer our comments can also be difficult, and we should be fairly certain that our comments are truthful and necessary. It often seems so easy to criticize others because we mistakenly believe that we are without fault or are such experts on most everything. The Bible tells us that we look at the speck in our brother's eye, but we pay no attention to the log in our own (Luke 6:41). Faultfinding and being overly critical of others, especially behind their backs, are wrong and can become habit-forming. However, kind words are good for the soul and help to build a person up.

The way of a fool is right in his own eyes, but a wise man listens to advice. RSV Proverbs 12:15

Use prevention, care to stop parasites

Entertainment, the combination of information and entertainment, makes information fun for the listener so they learn more. It's all over television and radio, even in classrooms.



About Animals

Dr. Brad Davis

Important, but boring

Thus I will insert animal jokes within the text, to keep the subject interesting (And, yes, I use the terms "joke" and "interesting" very loosely)

ALL ABOUT ROUNDWORMS

Detroit area veterinary clinics tend to commonly find roundworms and hookworms, especially in the stool samples of puppies and kittens. Adult dogs get these worms through contact with infested stool.

They can be easily treated with an oral wormer, and can easily be prevented with an appropriate heartworm preventive, as several now contain intestinal parasite controls.

Yes, these can be infectious to people, and can cause a great deal of damage. Still, if everyone uses proper hygiene, like washing hands after dealing with the new puppy, and not using the cat as a plate for your sandwich, you should do all right.

Ask your vet about getting your dog or cat on the right preventive to keep your pets safe.

Here's a joke: Two elderly vultures doubted they could make the migration south, so they decided to go by plane. As they checked their bags, the attendant noticed that they were carrying two dead raccoons. "Do you wish to check the raccoons through as luggage?" she asked.

"No, thanks," replied the vultures. "They're carrion."

Fascinating information: When you talk about the bad boys of the intestinal parasite scene, whipworms have to be the king. Only affecting dogs, these parasites can cause problems that mimic cancer. The animal gets a diarrhea that can make you grimace, and then they begin to lose weight, often dramatically.

Treatment usually goes pretty easily once discovered by a stool sample, but another problem with the parasite would be its staying power. The infested yard remains so until the top several inches of dirt and cement are removed, and dried hay is spread around and burned. (Don't do that, there's a better way.)

Once again, certain heartworm preventives control these parasites. Going year round with these preventives can keep your animal safe, even if you go to an infested yard or park.

EASY TREATMENT

More fascinating information: Everybody knows tapeworms, from urban legends to jokes that someone who can't gain weight has one. In the old West, snake oil salesmen would sell the segments of the tapeworm to townspeople as diet pills. (Thank God for the FDA!) While people can get transient infections, dogs and cats get tapeworms from consuming an infested flea or rodent. They must pass through one of these species to become truly infectious.

These are treated easily, but diagnosis can be difficult with a stool sample, as the segments are far too big for a microscope, looking like grains of rice on the skin around the animal's rump.

Giardia and coccidia are one-celled parasites that can be hard to treat.

If your pet has diarrhea, get the stool evaluated. Early detection can hurry a cure, and delay can lead to dehydration.

Joke: A man tried to sell his neighbor a new dog. "This is a talking dog," he said. "And you can have him for five dollars."

The neighbor said, "There ain't no such thing as a talking dog!"

Suddenly the dog looked up with tears in his eyes. "Please buy me, sir," he pleaded. "This man is cruel. He never buys me a meal, never bathes me, never takes me for a walk. I used to be the richest truck dog in America. I performed before kings. I was in the army and was decorated ten times."

"Hey!" said the neighbor. "He can talk! Why do you want to sell him for just five dollars?"

"Because," said the seller,

"I'm getting tired of all his lies. Thanks. I'll be here all week. Try the corn dogs."

Dr. Brad Davis is the Medical Director for the VCA of Garden City, 2085 Inkster Road, Garden City, MI 48135. Write him there with questions and comments. Listen to his nationally syndicated radio show Animal Talk, now heard on WDSO 1480 am or visit their Web site www.AnimalTalkRadio.com. Send E-mail questions or comments with your e-mail address to Questions@animaltalkradio.com.



SCHLEGEL

Richard A., 78, died peacefully at home in Jensen Beach, Florida, on Sunday, March 21, 2004. He is survived by his loving wife of 53 years, Margot Schlegel, his five children: Mark, Michael (Cynthia), Margot Cromack (Douglas), Matthew (Nancy Dewan), and Amanda Cocksels, his ten grandchildren: Hannah Schlegel, Emily Cocksels, Daniel Schlegel, Drew Schlegel, Margot Ann Cromack, Christopher Schlegel, Philip Cromack, Benjamin Schlegel, Erika Cromack, and Allison Schlegel, and his brother G. David Schlegel (Janet). Born in Reading, Pennsylvania, Dick attended Harvard College and pursued postgraduate studies at the University of Pennsylvania. After World War II, Dick spent two years in Germany with the American Friends Service Committee, assisting the citizenry recover from the war. Dick then spent a number of busy and exciting years as a producer during the early development of television before switching careers to become a teacher so that he could spend more time with his growing family. In 1965, Dick moved his family to Beverly Hills, Michigan, where he devoted 20 years to developing a nationally recognized private education program as headmaster of Detroit Country Day School. Dick loved his work and the dedicated people with whom he worked, and he considered both the faculty and the students who passed through Detroit Country Day School over the years to be part of his extended family. During his tenure at Detroit Country Day School, Dick spent his off-time riding dressage in Michigan and as a gentleman farmer in Vermont. Following his retirement, Dick became a snowbird, spending his over-lengthening winters in Florida, where he remained an ardent tennis player. Dick became an active member of St. Mary's Episcopal Church in Stuart, Florida, and he thoroughly enjoyed the fellowship of singing in the St. Mary's choir and St. Lucia chorale. No flowers please. Memorial contributions may be made to the Detroit Country Day School Scholarship Fund, 22305 West Thirteen Mile Road, Beverly Hills, MI 48025. A Memorial Service will be held on Saturday, April 17, 2004, at 11:00 am at Christ Church, Cranbrook in Bloomfield Hills, Michigan.

GROTH (POPIANAS)

Stella Maria, 71, of Livonia, died March 22, 2004. She is survived by her husband Carl (Dick) Groth, son Karl (Lori) Mother Mary Popianas and four grandchildren: Christopher, Emily Ann, Jonathan and Zachary. She was predeceased by her son Kenneth, sister Rodica and father Virgil. Stella was born in Romania and emigrated to Dearborn, MI, in 1946. She attended DIT and graduated with a BS in Chemistry. She met her husband while working for Rickett Malt Company and was married 57-58. In 1959, she became a full-time homemaker and had her first son, Karl. In 1961, she had her second son, Kenneth. She was very active with Garfield PTA and when her boys were old enough, she went back to work with Livonia Public Schools as a Science Para-Professional. When opportunity knocked, she took up the challenge of special education. Para-Professional at Livonia Skill Center. This allowed her to teach and guide developmentally disabled (Downs Syndrome) students. She loved every teaching moment and her students. She finally retired in 1997 when she suffered a stroke. She was an avid golfer and won trophies as Senior Lady Golf Champion. Her greatest joy was her Hole in One in 1989. Burial took place March 25 at Grand Lawn Cemetery in Royal Oak.

DeORLOW

Laura Katherine, Mrs. Harold DeOrlow, of Old Port Cove, North Palm Beach, Florida, passed away at a local hospital on Friday night, March 19, 2004. She was born in Dunning, Maryland, the daughter of the late David and Mary Ellen Stern. Mr. and Mrs. DeOrlow lived in Detroit for over 50 years and raised their children in Birmingham, Michigan. They have resided in Old Port Cove, Florida, the past 23 years. They were both active members of the Detroit Yacht Club, the Little Traverse Yacht Club and Harold was Commodore of the Grosse Pointe Yacht Club, Old Port Yacht Club and the Detroit River Yachting Association. Mrs. DeOrlow is survived by her devoted husband of 65 years, Harold Stephen DeOrlow, three children: Stephen DeOrlow of San Diego, California; Charlotte, Aurox of Pacific Palisades, California; and Suzanne Goodman of Bloomfield, Michigan, and six grandchildren.



Sister Mary André Lytle, RSM Sister Of Mercy, Teacher, Administrative Assistant

(Farmington Hills, MI) - Sister Mary André Lytle, RSM, died on March 21, 2004, at McAuley Retirement Center in Farmington Hills. She was born on September 1, 1908, in Beaverton, Ontario, Canada, to James and Josephine (Brennan) Lytle and baptized Marion Veronica in the parish church. She worked as an office assistant for nine years before joining the Sisters of Mercy at Mt. St. Agnes in Dubuque, Iowa, in 1936. She received the name Sister Mary André and made perpetual vows at the Sisters of Mercy Provincialate in Detroit on August 16, 1942. Sister Mary André completed her Bachelor of Arts degree at Mercy College of Detroit. She served as office assistant and payroll clerk for several years at Mercy hospitals in Grand Rapids and Jackson, Michigan. She taught grades one through five for 11 years at schools in Cadillac, Posen, Bay City, and Midland. Her next responsibilities were in secondary education, teaching commercial and business courses in Muskegon, Pinconning, Bay City, Saginaw, Grand Rapids, and Farmington Hills. From 1970-1981, Sister Mary André served as the attendance officer at Mercy High School where she met and advised many young women. In 1981, she became the official records keeper for the Sisters of Mercy Province of Detroit and continued this responsibility until she retired to McAuley Center in 1998. Sister Mary André is remembered for her gentle, cheerful manner, her keen interest in others, and her ability to bring a calming perspective in difficult situations. Her quiet presence and counsel reflected an inner peace. Sister Mary André is survived by several nieces and nephews and by the members of the Mercy community. A welcoming service and prayer vigil were held at McAuley Center on Tuesday, March 23, 2004. The funeral Mass was celebrated on Wednesday, March 24, in the Sacred Heart Chapel at McAuley Center. Arrangements are under the direction of McCabe Funeral Home, Farmington Hills, MI. Memorial contributions may be sent to the Mercy Ministry Fund, 29000 Eleven Mile Road, Farmington Hills, MI 48336-1405.

BROWN

Victoria, age 45, of Plymouth, Michigan, passed away on March 22, 2004. She was born on October 26, 1958, in Wayne, Michigan. She is survived by her husband, Jeffrey Brown, of Plymouth, children Molly (Brian) Szweczyk of Canton, MI; Jillian Brown and Rachel Brown of Plymouth, MI; grandchildren Ethan and Drew Szweczyk; parents, Raymond and Leola Douglas of Plymouth, MI; in laws, Ronald and Joyce Brown of Arizona. She was preceded in death by her father, Ryan Brown. Victoria has been a Dental Hygienist since 1982. She lived in Plymouth all her life. She was a member of St. Peter's Evangelical Lutheran Church where she taught Sunday School. She was a loving wife, mother, grandmother, daughter, and daughter-in-law. Memorial Services will be held at St. Peter's Evangelical Lutheran Church, 1343 Penman, Plymouth with Pastor Paul Schaefer officiating. Memorials may be given to St. Peter's Evangelical Lutheran Church. Local arrangements by the Schrader Howell Funeral Home, Plymouth.

MECH

James, of Farmington Hills, MI, died on March 23, 2004, after a courageous battle with cancer. He was 70 years of age. Beloved husband of Anne, dear father of Randolph, Gregory, and David, brother of Arthur (Cathy) Mech, uncle of Arthur, Kevin, and Colleen. At the request of the family, a private funeral service will take place. Memorial donations can be made in James' name to Karmanos Cancer Foundation, 18831 West 12 Mile Rd., Lathrup Village, MI 48076. Arrangements entrusted to the Union Lake Chapel of the Elton Black & Son Funeral Home, 1233 Union Lake Rd., White Lake.

Flower Directory

These area florists are standing by waiting to assist you with your floral arrangement needs.

For more information on how you can start your Floral Business here please call: 1-800-579-7355

FARMINGTON CENTER FLORIST
23340 Farmington Road
Farmington MI 48336
888-814-4726 • 248-474-4726
24 Hour Phone Service
Store Hours 8-6 M-F 8-4 Sat

FREE DELIVERY
Flower King of Livonia
34899 Plymouth Road
Livonia, MI 48150
800.657.6749 • 734.513.8000
www.flowerkingoflivonia.com

Wesley Berry Flowers
1-800-WESLEYS
6677 Orchard Lake Road
www.800wesleys.com

Passages

Obituaries, Memorials, Remembrances

1-800-579-7355 ♦ fax: 734-953-2232

e-mail: OEObits@oe.homecomm.net

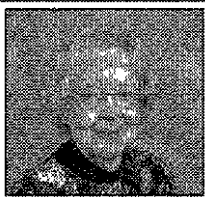

Sister Mary André Lytle, RSM

(Farmington Hills, MI) - Sister Mary André Lytle, RSM, died on March 21, 2004, at McAuley Retirement Center in Farmington Hills. She was born on September 1, 1908, in Beaverton, Ontario, Canada, to James and Josephine (Brennan) Lytle and baptized Marion Veronica in the parish church. She worked as an office assistant for nine years before joining the Sisters of Mercy at Mt. St. Agnes in Dubuque, Iowa, in 1936. She received the name Sister Mary André and made perpetual vows at the Sisters of Mercy Provincialate in Detroit on August 16, 1942. Sister Mary André completed her Bachelor of Arts degree at Mercy College of Detroit. She served as office assistant and payroll clerk for several years at Mercy hospitals in Grand Rapids and Jackson, Michigan. She taught grades one through five for 11 years at schools in Cadillac, Posen, Bay City, and Midland. Her next responsibilities were in secondary education, teaching commercial and business courses in Muskegon, Pinconning, Bay City, Saginaw, Grand Rapids, and Farmington Hills. From 1970-1981, Sister Mary André served as the attendance officer at Mercy High School where she met and advised many young women. In 1981, she became the official records keeper for the Sisters of Mercy Province of Detroit and continued this responsibility until she retired to McAuley Center in 1998. Sister Mary André is remembered for her gentle, cheerful manner, her keen interest in others, and her ability to bring a calming perspective in difficult situations. Her quiet presence and counsel reflected an inner peace. Sister Mary André is survived by several nieces and nephews and by the members of the Mercy community. A welcoming service and prayer vigil were held at McAuley Center on Tuesday, March 23, 2004. The funeral Mass was celebrated on Wednesday, March 24, in the Sacred Heart Chapel at McAuley Center. Arrangements are under the direction of McCabe Funeral Home, Farmington Hills, MI. Memorial contributions may be sent to the Mercy Ministry Fund, 29000 Eleven Mile Road, Farmington Hills, MI 48336-1405.



JOIER, ROYCE TYLER

April 3, 1985 - March 19, 2004
Royce Tyler died in a car crash on Friday, March 19th, 2004, in Southfield, MI. Royce was born in Southfield, MI. He was a graduate of Southfield Public Schools and his high school was Southfield High School with honors in 2003. Royce was on the varsity Soccer Team and was a lead player on the chess team for three years. He was a talented artist and enjoyed sketching and computer aided design. He most recently attended Oakland Community College and New Horizons Computer Learning Center in Livonia, Michigan. He was accepted and planned on attending the University of Advancing Technology in Phoenix, AZ, in the fall of 2004, majoring in Computer Science. His ultimate goals in life were to operate his own gaming design company, help to bring about racial tolerance, and to lead others to a stronger belief in God. He laid the groundwork for his life's goals every day of his life. He leaves behind his parents, Carolyn (Monk) Joier and Eric Joier of Southfield; Sister Jillian Joier of Southfield; Grandmothers (maternal) Dorothy Monk of Flint, MI, and Rowana Gilh (paternal) of Southfield. He also leaves behind Aunts and Uncles (maternal) Richard and Nancy Monk of Sterling Heights, MI; Christine Monk of Flint, Stanley A. Monk of Flint; Thomas Monk of Flint, and Cathy (Monk) and Tracy Fverhart of Linden, MI. He leaves behind aunts (paternal) Rosalind, Easter of Southfield, Angela Compton of Southfield, and Vicki Williams and Gerald Williams of Winter Springs, FL. Royce enjoyed loving relationships with cousins (maternal) Daniel Monk of Sterling Heights, Stanley Monk Jr. and Lisa Monk of Flint, and Spencer and Connor Everhart of Linden. He was like a brother to cousins (paternal) Johann Easter of Union City, NJ, and Lamanuel Compton Jr. Morgan Compton and Nicholas Compton all of Southfield. He is also survived by many other family members and many many friends in the Detroit area, in Flint and surrounding communities. Royce spent most of his summers growing up in Flint and considered it his second home. A memorial service is planned (in lieu of a funeral and burial) at Woodside Church located at 1509 East Court St., Flint, MI 48503 on Thursday, March 25, 2004 at 7:00 p.m. The family requests that donations (in lieu of flowers) be sent to and made payable to The Royce Joier Memorial Fund, PO Box 250697, Franklin, MI 48025.



SANDERS,

Walter Colem died on March 21, 2004, at Riverside Methodist Hospital in Columbus, Ohio. He was 67 years old. Born in Geneseo, New York, September 15th, 1936. Mr. Sanders was retired from General Motors where he was a long time executive with GM Photographic. A resident of Troy, MI, Sanders was active in community affairs. He was Vice Chairman of the Board of Directors of The Oakland Catholic Credit Union, a Grand Knight of the Knights of Columbus, a Eucharistic Minister at The Church of St. Alan, and a dedicated volunteer at The Detroit Institute of Arts. He was a member of the Sera Club, a Catholic organization that fosters and promotes religious vocations. For years Mr. Sanders was a Scoutmaster of The Holy Name Boy Scout Troop #1031 in Birmingham, MI. He served as a marshal and as a director of The Buick Open and was active in several other major golf tournaments. He was a graduate of Geneseo High School and Salisbury School. He attended Brown University where he was a member of the Phi Kappa Psi Fraternity. He received a degree from Rochester Institute of Technology and a master's degree in marketing from Wayne State University. His father, Donald R. Sanders, was owner of Sanders Publications, which published 10 weekly newspapers in western New York. The first newspaper was founded by his great grandfather, Chauncey K. Sanders in 1859. His wife, Marilyn Cann Sanders, was a teacher at the Holcombe School in Geneseo, New York. Mr. Sanders is survived by his wife, Marilyn Cann Sanders of Troy, Michigan; son, Scott Coleman Sanders of San Francisco, California; daughter, Kristin Sanders Fiorita (Robert) of Dublin, Ohio, and grandchildren, Carter, Kendall, and Cameron Fiorita, a brother, Donald R. Sanders (Virginia) of The Woodlands, Texas; sister of Laurie Ann Sanders Kenny (Jack) of Tiburon, California, and Aunt Jane Wassung of St. Augustine, Florida; niece, Samara Sanders Lundberg (Eric Leif Laula) of Havana, Cuba; niece, Aimee Sanders of Brooklyn, New York. A funeral mass will take place on Monday, March 29th, at 10:00 A.M. at St. Mary's Catholic Church in Geneseo, New York. In lieu of flowers, the family requests donations may be made to The Detroit Institute of Arts. Mr. Sanders was predeceased by his parents, Kathryn and Donald Sanders, brother, Chauncey K. Sanders, and Uncle Frank R. Wassung. Funeral arrangements by Rector-Hicks Funeral Home, Inc., 111 Main St., Geneseo, NY (585) 243-0995.

BARNES

Jacqueline, March 22, 2004. Age 72 of Lake Orion. Beloved wife of Allen C. of 49 years. Dear mother of Julie (James) Manis of Dublin, OH, David (Barbara) Barnes of Orion Twp and Skip (Connie) Barnes of Lake Orion. Grandmother of Candace, Christopher Danny and Charlotte. Born in Binghamton, NY on February 6, 1932 to Murrell and Julia Hall. Mrs. Barnes was a 2nd grade teacher at Armada Elementary for 22 years. She obtained a Baccalaureate Degree from the University of Akron. She also obtained a Masters Degree from Wayne State University. She was a Board Member for the Orion Historical Society. Funeral service Saturday 2pm @ the Lake Orion Chapel of the Sparks-Griffin Funeral Home. Family will receive friends Friday after 3pm, with suggested visiting hours of 3:5 & 7-9 pm. In lieu of flowers, memorial contributions may be directed to Orion Historical Society, PO Box 817, Lake Orion, MI 48361.

RENTSCHLER

Carl F. Jr., age 78, of Leonard, MI, died March 20, 2004. Survived by his wife Marion, daughters Sheila Smith and Carol Rhodes, grandchildren Robin Wright and Carl Smith. Preceded in death by his daughter Kim Holly and his brother William. Arrangements by Henry M. Malburg Funeral Home of Romeo, MI.

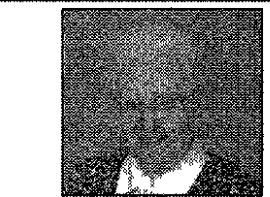

SISTER MARY VICTORINE RAPIN, RSM Sister Of Mercy, Principal, Pastoral Minister

(Farmington Hills, MI) - Sister Mary Victorine Rapin, RSM, a Sister of Mercy for 77 years, died on March 21, 2004, at McAuley Retirement Center in Farmington Hills. She was born on April 5, 1908, in Saginaw, Michigan, to Charles and Rachel (LeFebvre) Rapin and christened Irma Mary at St. Andrew's Church. She joined the Sisters of Mercy in 1927 at Mt. Mercy Academy in Grand Rapids, Michigan, where she received the name Sister Mary Victorine. She professed perpetual vows on August 15, 1933. Sister Victorine earned a bachelor's degree from Ferris Institute in Big Rapids, Michigan, a master's degree from University of Detroit and a doctorate in education from Wayne State University. She spent 16 years teaching students in Ludington, Grand Rapids, Cheboygan, Muskegon, Bay City, and Detroit before becoming assistant principal at Our Lady of Mercy High School in Detroit in 1946. She was appointed principal in 1952. During her 17 years as principal, Mercy High School expanded from 125 to 1,300 students and outgrew its location, prompting the move to its current site in Farmington Hills. Under Sister Victorine's guidance, the school developed a tradition of excellence in academic discipline. She initiated several customs that have become hallmarks of the school, including the graduation ceremony with white gowns and red roses. In 2002, Sister Victorine was inducted into Mercy High School's Hall of Fame where she was recognized for outstanding leadership in administration and for being the guiding force for the old and the "new" Mercy High School. Sister Victorine also served in community leadership for the Sisters of Mercy and as administrator of Mercy Center. In 1972, after earning certification as a clinical pastoral minister, she was appointed the first director of pastoral ministry for St. Joseph Mercy Hospital in Ann Arbor. She served in this capacity for 20 years, later becoming pastoral advisor to the department and coordinator of liturgical volunteer ministries. Sister Victorine recruited approximately 60 volunteers who bring communion to patients on a daily basis, and she herself was a well-known and well-loved presence on the patient units. To commemorate her 75th Jubilee as a Sister of Mercy, the hospital commissioned a bronze relief of St. Therese of the Little Flower for the hospital chapel. Sister Victorine continued working until the day that a stroke forced her retirement to McAuley Center in 2004. Sister Victorine is survived by several nephews and nieces, including Sister Mary Judith Rapin, RSM, and by the members of her Mercy community. A welcoming service will take place on Wednesday, March 24, at 3 pm at McAuley Center, followed by a scripture and remembrance vigil that evening at 7 pm. The Mass of Resurrection will be on Thursday, March 25, at 10:30 am in the Sacred Heart Chapel at McAuley Center. Burial will follow in Holy Sepulchre Cemetery, Southfield. Arrangements are under the direction of McCabe Funeral Home, Farmington Hills. Memorial contributions may be made to the Mercy Ministry Fund, 29000 Eleven Mile Road, Farmington Hills, MI 48336-1405. Donations to a scholarship fund in Sister Victorine's name may be made to Mercy High School, President's Office, 29300 Eleven Mile Road, Farmington Hills, MI 48336-1409.

Let others know...

When you've lost a loved one, place your notice on our website and in "Passages" a directory located in every edition of your hometown newspaper.

Observer & Eccentric
Call 1-800-579-7355

www.hometownlife.com

Store hosts Garden Party Weekend, April 3-4

Plan your weekend activities each Thursday with Filter

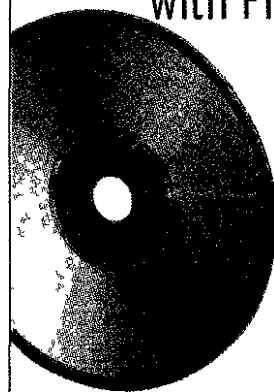

English Gardens will host its annual Garden Party Weekend, April 3 and 4 at all five English Gardens stores. The weekend includes free gardening seminars and information, photos with the Easter Bunny, and refreshments.

Spring is here and we are ready to garden," says John Darn, president of English Gardens. "English Gardens Garden Party Weekend is our annual spring celebration where we officially launch the gardening season and kick off National Gardening Month."

The Easter Bunny will be available for photos on 11 a.m. - 3 p.m. Saturday and noon-3 p.m. Sunday.

Free seminars include presentations on *What's New in Container Gardening* by Jim Wilson and *New Annuals and Perennials* by Nancy Szerlag, gardening columnist and author. There will also be presentations on creating a healthy soil ecosystem, lawn care, landscaping, water gardening, orchids, and arranging fresh flowers.

Presentations are planned from 10 a.m. to 4 p.m. on Saturday and 11 a.m. to 3 p.m. on Sunday at all five English Gardens stores. Topics and presenters include:

- *What's New in Container Gardening*, by Jim Wilson

One of the fastest growing trends is gardening in containers. See new ideas and learn the secrets of a successful container garden, including selecting plants, proper planting, fertilizing and care.

Appearances are 4 p.m. Saturday in Royal Oak, 11 a.m. Sunday, Dearborn Heights, and 2 p.m. in West Bloomfield.

- *Compost Tea and Living Soil for Healthy Plants*, by Scott Subler. Successful gardening starts with the soil. Learn how natural, biologically active products, such as earthworm casting and compost teas, can help ensure a healthy and productive soil ecosystem. Appearances are 10 a.m. Saturday in Royal Oak, and 1 p.m. Dearborn Heights, and 11 a.m. Sunday in West Bloomfield.

- *New Annuals & Perennials*, by Nancy Szerlag, gardening columnist. Learn about new varieties of annuals and perennials for 2004 and how to care for them. 10 a.m. Saturday in West Bloomfield, and 1 p.m. in Royal Oak.

- *Enhancing Your Home's Value with Landscaping*, by English Gardens Landscape Designers. An attractive, well-designed and maintained landscape can increase your home's value by 10 to 20 percent. Learn how to create an

outdoor environment that's beautiful and extends your home's living space at 1 p.m. Saturday in West Bloomfield, and 11 a.m. Sunday in Royal Oak and 2 p.m. in Dearborn Heights.

- *Arranging Fresh Flowers*, by English Gardens Floral Designers. See a step-by-step demonstration of arranging fresh flowers, with design basics and lots of inspiration and ideas at 4 p.m. Saturday in Dearborn Heights and at 2 p.m. Sunday in Royal Oak.

- *Introduction to Water Gardens*, by Farley See, Moore Water Gardens. Water gardening continues to increase in popularity. Get information on creating a water garden, selecting plants and caring for it throughout the year at 4 p.m. Saturday in West Bloomfield.

- *The Grass Can be Greener*, by Chip Hickey, English Gardens sales associate. A lush green lawn is the foundation for a beautiful garden. Learn all the basics of caring for and improving the health and appearance of your lawn. Saturday 10 a.m. Dearborn Heights.

- *An Introduction to Orchids*, by English Gardens expert. Learn about this popular and long-lasting flowering plants. We'll present

information on popular orchid varieties, including care and re-blooming tips. Sunday 11 a.m. Eastpointe.

Representatives from the Detroit Rose Society will be available to offer advice on selecting and growing roses from 11 a.m. to 4 p.m. on Saturday and Sunday at all five stores.

Additionally Master Composter volunteers from SOCWA (Southeastern Oakland County Water Authority and Groundwater Stewardship Program) will be at the Royal Oak and West Bloomfield stores on Saturday from 9:30 a.m. to 4:30 p.m. to

answer questions on making and using compost, as well as using natural mulches. Master Recycler volunteers from the City of Royal Oak will provide information on recycling on Saturday from 10 a.m. to 4 p.m. English Gardens stores are located at 6370 Orchard Lake Road in West Bloomfield (248) 851-7506, 4901 Coolidge in Troy, (248) 280-9500 and 22650 Ford Road at Outer Drive in Dearborn Heights (313) 278-4433.

Call 1-800-335-GROW (4769) for the nearest English Gardens location, or check the web site at www.englishgardens.com

Guardian Martial Arts & Fitness

Proudly Presents:

The First Annual WOMEN'S WELLNESS WEEKEND

March 26, 27 & 28
Fri. 6-9; Sat. 9:30-5 & Sun. 11-3

FEATURING:

Healing Touch, Reiki, Aromatherapy, Pilates, Massage, Tai Chi, Self-Defense, Step-Aerobics & Much, Much More!

Women's Wellness Weekend Special Guest:
Ms. Claudia Ogden, R.N.
Integrated Medicine, U of M Hospital
Certified Holistic Nurse, Healing Touch Practitioner, Aromatherapy Practitioner & Instructor

• Ms. Ogden will teach a 1 1/2 hour seminar on: **WOMEN & STRESS** •

ADMISSION: \$5.00 PER DAY OR \$7.50 FOR ALL THREE DAYS

Guardian Martial Arts & Fitness
30942 Ford Road • Garden City • (734) 266-0565

• LUNCH • ARBONNE SKIN CARE • JEWELRY • BIO-FEEDBACK • FRIENDSHIP • DENTAL HEALTH • NATURAL HOME CARE PRODUCTS • PAMPERED CHEF • PHOTOGRAPHY • REAL ESTATE SERVICES • ACUPUNCTURE

HUGE MOVING SALE!

AFTER 27 YEARS

WE'RE MOVING

10,000 SQ. FT. SHOWROOM
ABSOLUTELY EVERYTHING
ON SALE

2 WEEKS LEFT!!!

LET'S MAKE A DEAL SALE!

No reasonable offers refused!

- | | |
|--|---|
| <ul style="list-style-type: none"> • Framed Art • Oil & Canvas Pictures • Decorator Mirrors • Floor & Table Lamps • Tapestries • Tiffany Table & Floor Lamps • Outdoor Patio & Casual Furniture • Ceiling Fans | <ul style="list-style-type: none"> • Lighting For Every Room in The House • Ducane & Lynx Gas Grills • Lloyd Flanders All Weather Wicker (Sectional & Sets) • From Traditional to Contemporary to Transitional • Home Accessories & Much, Much more... |
|--|---|

Special Event Hours on

Sundays 12:00 Noon to 4:00 PM

thru April 4th.

Look for the Opening of Our
New 14,000 Sq. Ft. Showroom
April 10th at 1405 S. Lapeer Rd.
(Right Next Door to Our Existing Location)

PINE TREE LIGHTING

"We Turn On Interiors"

(248) 693-6248

1447 S. Lapeer Rd. • Lake Orion • www.pinetreelighting.com

Mon-Thurs 9:30 am - 8 pm Tues Wed Fri 9:30 am - 6 pm

Sat 9 am - 5 pm Sunday 12 noon to 4 pm

I-75 N to exit 81 N - 4 Miles north of the Palace of Auburn Hills

We're thinking fresh.

HAYSTACK CONTEST!

Farmer Jack and the Observer & Eccentric have teamed up to bring you great prizes and great fun, when you play our Hidden Words in the Haystack Contest.

Just find the words in the word haystack that are listed beneath the puzzle and circle them. They may be found from right, left, diagonally, up or down.

All the words must be found in order for your entry to be considered valid. Clip the completed game including the entry blank and mail it to us at:

Farmer Jack/O&E Haystack Contest
36251 Schoolcraft Road
Livonia, MI 48150

Week 5 entries must be received by April 2nd for the Week 5 drawing for:

One (1) First Prize of a \$50 Farmer Jack Gift Card
Three (3) Runner Up Prizes of a \$25 Farmer Jack Gift Card

All entries will be in contention for the grand prize of a \$500 SHOPPING SPREE AT FARMER JACK!!

Only 3 more weeks to enter. No purchase necessary. For contest rules, please visit our website at www.hometownlife.com/oecontestrules. Winners names will be published at contest's end.

WHERE HOMETOWN STORIES UNFOLD

HAYSTACK GAME

WEEK 5

Service

Smile

Parking Lot

Ham

Writers

Cheese

Canton

Troy

Rochester

Lottery

Cereal

Reading

Articles

Sports

Meat

J	P	I	N	O	T	N	A	C	E	L	I	M	Q
A	N	P	E	I	R	E	A	D	I	N	G	K	O
T	U	S	A	N	O	T	R	O	L	T	T	I	E
E	W	N	L	R	Y	S	T	R	O	P	S	P	Q
S	B	U	C	H	K	T	I	L	T	N	O	E	U
R	T	A	E	M	K	L	G	A	T	T	E	S	N
E	A	L	C	D	A	N	F	G	E	E	K	E	M
T	U	T	A	E	I	E	G	E	R	S	O	L	A
I	C	R	K	K	L	C	E	Y	E	L	C	M	
R	U	E	R	N	E	I	C	O	N	E	B	I	V
W	C	A	K	A	V	M	E	I	C	H	R	T	I
A	P	N	I	R	E	S	T	F	A	C	M	R	N
H	K	O	E	B	C	D	E	M	Q	W	E	A	Y
W	L	S	R	E	T	S	E	H	C	O	R	M	O

Here's my entry form for the FARMER JACK/O&E Haystack Contest.

Name _____ Phone: _____

Address _____ City _____ Zip _____

How do you get your O&E? (Check One)

Home Delivery
 Vending Machine
 Store
 Share with a friend/neighbor
 Mail subscription
 Sample

Side dish

Buddy's is best

Buddy's Pizza will be featured on The Food Network's *Best Of* show as one of the nation's five best pizza places. The show was taped at the original Buddy's at 6 Mile and Conant in Detroit. The *Best Of* host, Jill Cordes, and her crew taped in the kitchen, dining room and bocci court of the restaurant. The show will be broadcast at 5 p.m. Saturday and 4 p.m. Sunday. Buddy's has many locations in the metro area, including Auburn Hills, Farmington Hills and Livonia, along with carry-outs in Bloomfield Township and Royal Oak. For more information, visit www.buddyspizza.com.

Home show cooks

Now is the time to make sure your summer barbecues are not the same old recipes by visiting the Novi Spring Home and Garden Show. The show's cooking stage will feature Dianna Stoffer, chef for Certified Angus Beef, who will offer grilling ideas, including grilled beef and



bacon pizza and beef and peach salad. Stoffer will appear at 1, 4 and 7 p.m. Friday, April 2, and 1 and 3 p.m. Saturday, April 3 at the show at the Novi Expo Center. Chef Patrick Koziarski from Tom's Oyster Bar will appear on the stage at noon Sunday, April 4.

Certified Angus Beef will offer samples of pot roast and chili. Visitors can register to win a Certified Angus Beef product from Meijer and a Broil King Port-A-Chef grill for tailgating or camping. For information on where you can purchase Certified Angus Beef or recipes, visit www.certifiedangusbeef.com.

Hunt morels

Enjoy searching for the elusive morel mushroom in Michigan's north woods, then sample Michigan wine and dine on various wild mushroom dishes at Springbrook Hills in Walloon Lake. The weekend of April 30-May 2 features wines from Shady Lane Sellers of Suttons Bay. On May 14-16, a selection of wine from Leelanau Peninsula wineries caps your weekend. On May 21-23, it's Leelanau wines again that preface the mushroom dining delights.

This outing costs \$179 per person, which includes two nights lodging, guided morel hunting, mushroom information and lore plus the Saturday evening wine and dining. Groups of six or more are \$169 per person complete. If no lodging required, cost is \$124. Beginners and expert mushroomers alike will enjoy this weekend of fun and good food. Guests get extra nights lodging at \$20 per person. For reservations, call (231) 535-2227.

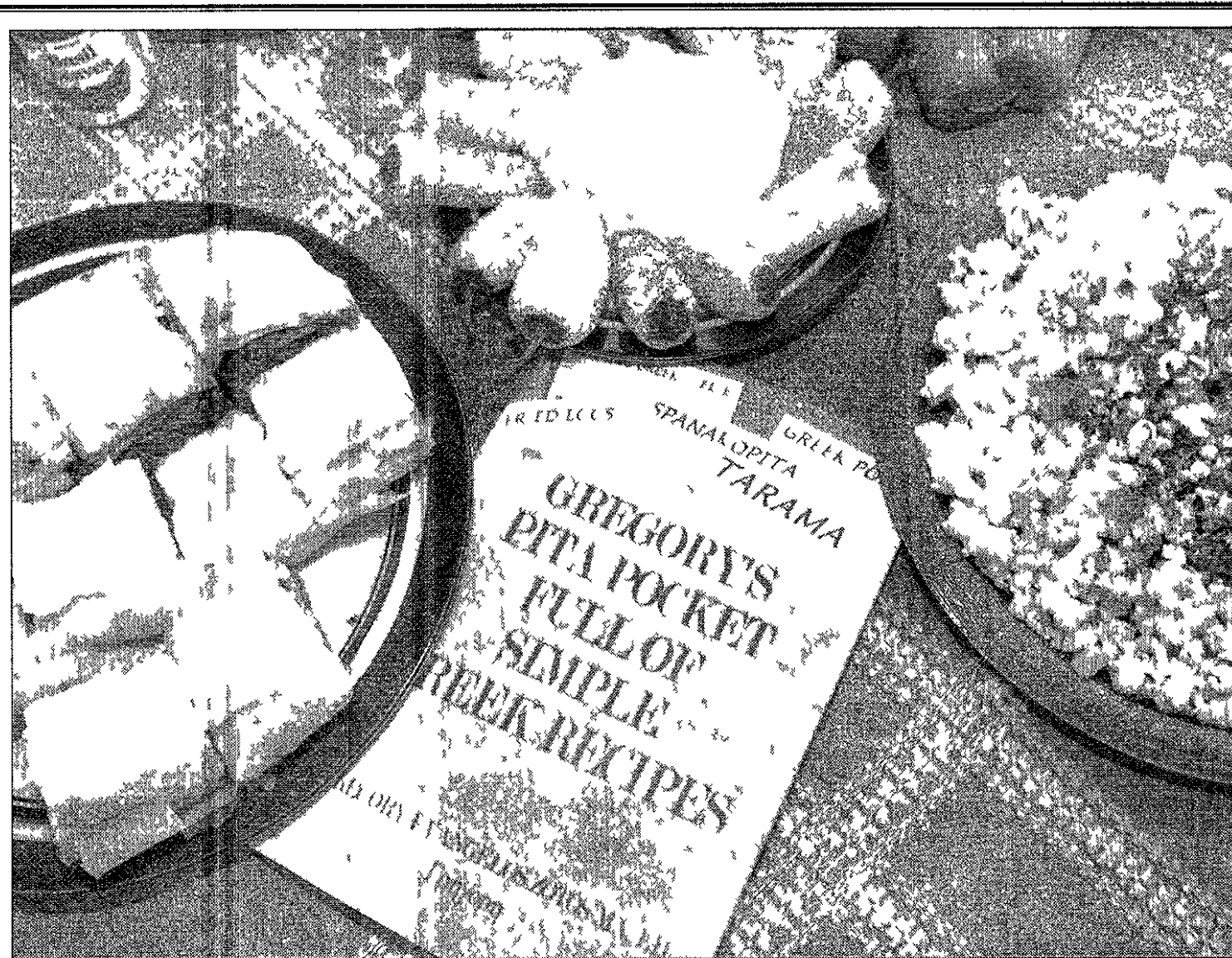

Greg Zotos' cookbook features recipes for spinach pie, Tzatziki and Greek popcorn.

Remembering

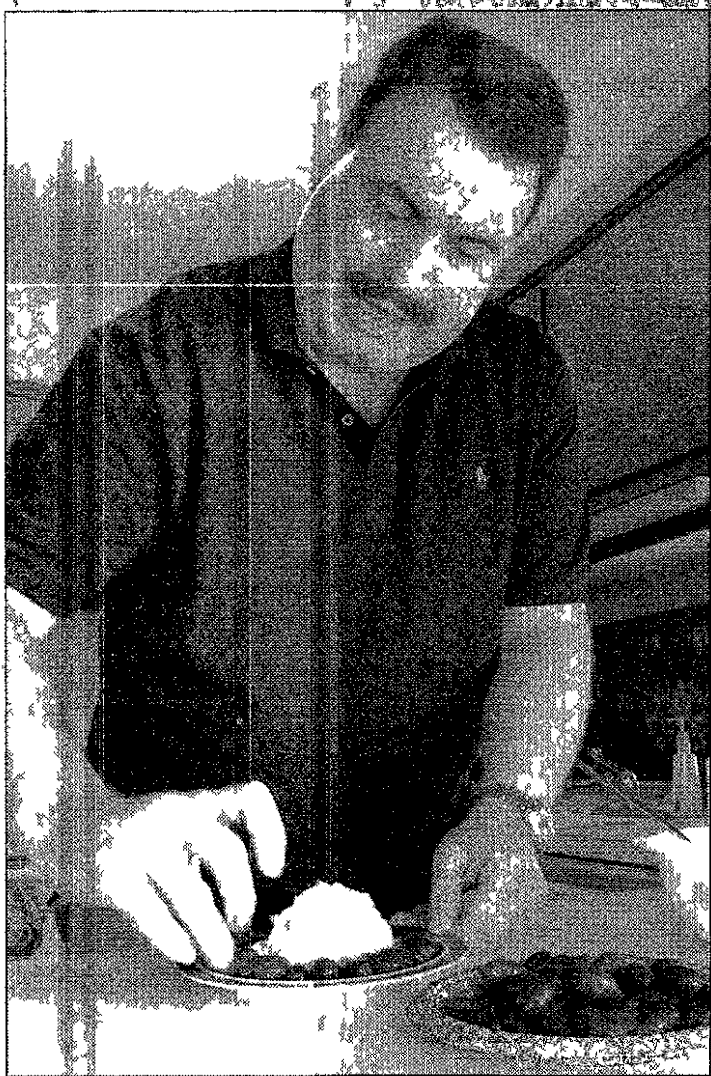

Greg Zotos of Livonia places Greek olives around a plate of tarama.

Instructor remembers travel, food from parents' homeland

Gregory Zotos had a little time on his hands. The Livonia resident and instructor at Schoolcraft College in Livonia was working on his master of fine arts in education from the University of Phoenix and had a week break between classes.

Zotos, who is a member of St. Nicholas Greek Orthodox Church in Troy, loves to cook. Zotos decided to write down a few ideas for some Greek recipes.

"I'd experiment in the kitchen and put things together," Zotos said. "As I was experimenting, I thought, 'This was a neat idea' and 'I'd write things down.'"

Zotos soon had several recipes. "Just for fun," he says, he bundled them up in an

PLEASE SEE GREECE, D3

Castello del Terriccio is on the rise in Tuscany

Dating back to the mid-1800s, Castello del Terriccio is a 4,200-acre estate located on the Tuscan coastline of Italy. The estate is divided into a northern half that grows cereal grains including



Focus on Wine

Ray & Eleanor Heald

wheat, corn and barley on white clay soils and a southern half that supports vineyards, olive trees and fruit trees on soils composed of clay and rocks.

During the 1990s, the production of cereal grains gradually gave way to vineyards with varieties, such as cabernet sauvignon, sangiovese and merlot. Most of the white wine acreage is devoted to chardonnay and sauvignon blanc. During harvest, pickers pass through the vineyards at least twice to guarantee perfectly ripened clusters.

Under the direction of Carlo Ferrini, Castello del Terriccio creates estate-grown, limited-production super Tuscan wines. Super Tuscan wines are internationally styled red wines, made with non-traditional Tuscan grape varieties such as cabernet sauvignon and merlot, frequently blended with Tuscany's traditional variety, sangiovese.

SINGLE-MINDED WINES

Terriccio's reds are single-vineyard wines named after the specific vineyards. Lupicaia means "the place of wolf hunts" and Tassinai is translated as "the place of stones." To ensure extra body and smooth tannins, both wines undergo extended skin contact or maceration after fermentation is completed.

Lupicaia is then aged for 18 to 20 months in French Allier forest oak, known for its tight grain. Tassinai is aged for 12 to 14 months, after which each wine is bottled following a rough filtration. Through its first four releases, 1995 through 1998, Lupicaia earned four consecutive Gambero Rosso magazine's tre bicchieri (three glasses) awards, the highest compliment in Italian wine.

White wines of Castello del Terriccio include Rondinaia, 100 percent chardonnay and Con Vento, 100 percent sauvignon blanc. Both wines are cold fermented in temperature controlled, stainless steel tanks, each undergoes partial malolactic fermentation and is bottled without oak aging.

TASTING WINES OF CASTELLO DEL TERRICCIO

A symbol of the Tuscan sun adorns the label of each Castello del Terriccio wine.

■ 2001 Castello del Terriccio Con Vento \$19 (sauvignon blanc) is introduced by bright citrus.

PLEASE SEE WINE, D2

Taste the wines of the Great Lakes at Oakland Community College

You can sample regional wines and support student scholarships at the ninth annual Great Lakes Great Wine Walk Around Tasting hosted by the Oakland Community College Culinary Studies on Thursday April 1. Starting at 6 p.m. on the third floor of Building J at

OCC's Orchard Ridge campus in Farmington Hills, the one-of-a-kind gala spotlights the unique wines produced by the distinct climate surrounding the Great Lakes. Before the event professional judges will taste and assess each of the 500 entries. Gold, Silver and Bronze medals will be awarded.

The public will be able to sip, swirl and savor such unique products as Ontario's famous Ice Wines, and sample great food prepared by OCC culinary students, as well as top area establishments including Great Oaks Country Club, Pine Lake Country Club, Steve & Rocky's and

Confectionately Yours Bakery.

Live background music to enhance the festive mood will be provided by the OCC Jazz Band.

Admission is \$50 and tickets are tax deductible.

All proceeds go toward scholarships for OCC culinary students, and for

the travel fund for the student chef competition team.

For further information call (248) 522-3700.

The Orchard Ridge Campus is located at 27055 Orchard Lake Road, just south of I-696. Ample free parking is available in nearby campus lots.

WINE

FROM PAGE D1

and gooseberry aromas. Generous fruit and balanced acidity on the palate result in an extended finish. A great choice with chicken, turkey, fish or fresh goat cheese.

■ 2002 Castello del Terriccio Ropinaia \$22 (chardonnay) highlights lemon and butter-scotch aromas with nuances of pear and apple. Fresh, crisp and well balanced, this elegant white wine is named for swallows' summer nests on the estate farmhouses.

■ 1999 Castello del Terriccio Tassinara \$35 (one third each sangiovese, cabernet sauvignon and merlot) has black and red raspberry flavors and a firm backbone of silky tannins followed by fine leather, smoke and chocolate nuances.

■ 2000 Castello del Terriccio Lupiccia \$115 (90 percent cabernet sauvignon, 10 percent merlot) is a big, complex mouthful of black cherry and cassis with myriad descriptors that include toast, berries, tobacco and clove. The structure is firm with well rounded tannins. Drink now or cellar up to 2014.

The Healds are Contributing Editors for the internationally respected Quarterly Review of Wines and Troy residents who write about wine spirals and restaurants for the Observer & Eccentric Newspapers. Contact them by e-mail at focusonwine@aol.com

WINE PICKS

The following are winners of our recent shoot out that included petite sirah. Outstanding 2000 Balmoral Syrah \$50 and 2001 Shafer Relentless \$55 (81 percent sirah 19 percent petite sirah). Excellent 2000 Foppiano Petite Sirah Reserve Estate Millennium Selection \$48 1999 Rosemount Mountain Blue Shiraz Cabernet \$45 2000 Joseph Phelps Syrah \$40 2001 Dutton Goldfield Cherry Ridge Vineyard Syrah \$35 and 2000 EXP Syrah \$14. Very Good 2000 Stags Leap Napa Valley Petite Syrah \$31 2001 Penfolds Bin 128 Coonawarra Shiraz \$24 2001 Penfolds Bin 28 Kalimna Shiraz \$24 2001 Arrowood Grand Archer Syrah \$20 and 2001 Alexander Valley Vineyards Two Barrel \$19 (70 percent sirah and 30 percent cabernet sauvignon). Wallet Friendly 2002 Lindemans Bin 50 Shiraz \$8 and 2003 [Yellow Tail] Shiraz \$7.

Ham and eggs are great for Easter and leftovers

Ham is a popular meat entrée and eggs are popular to hard-cook, color, decorate and hide for the Easter holiday. Both foods lend themselves to great meals and great leftovers.



Home Economist Lois Thieleke

Knowing how to choose, prepare and store ham and eggs will enhance your enjoyment of this year's celebration. Hams may be labeled fresh, cook before eating, fully cooked, picnic or country. Hams are either ready to cook or not, cured or cured-and smoked. This information may sound confusing, but you should read the label before buying.

If you buy a boneless or canned ham you can expect four-five servings per pound while a bone-in ham yields two to three servings per pound.

To serve ham heated, place the ham in an open uncovered roasting pan. Roast at 325° F to an internal temperature of 140° F (for fully cooked ham) or 160° F (internally) for cook before eating.

Apply your special glaze during the last 15 to 30 minutes of the roasting time. A country ham is entirely different, they are delicious but generally they are soaked in water and simmered until it reaches 150° F internally and then it can be roasted with a glaze. Slice very thin to serve.

HAM HANDLING TIPS:

■ Leave purchased ham in original wrapping in refrigerator for seven to 10 days. Slices should be used within three to four days.

■ Vacuum-packaged hams, unopened, will keep at least two weeks in the refrigerator.

■ Canned hams can be left at room temperature until ready to use (read the label).

■ Leftover cooked ham should be tightly wrapped, refrigerated within one to two hours after cooking and can be stored in refrigerator for four to five days.

■ Freezing deteriorates ham quality. If you must freeze, wrap tightly and store in freezer use within two months.

To ensure safe Easter eggs, do not leave hard-cooked dyed eggs at room temperature for more than two hours. Hard cooking destroys the eggs' natural shell protection and makes it more susceptible to bacterial growth.

Hard cooked eggs can be refrigerated for five to seven days. (They become rubbery if frozen.) After the eggs are hard cooked, dye them and return to the refrigerator within two hours. If eggs are going to be eaten, make sure you have used a food-safe coloring. Wash your hands before and after handling eggs.

Make two batches of hard cooked eggs. One batch is to eat and the other is for decoration.

If the table centerpiece is a basket of dyed eggs that are at room temperature more than two hours, do not eat these!

The eggs that are hidden should be placed in locations that are protected from dirt, insects, and pets, lawn chemicals or other sources of bacteria.

Always use the two-hour rule - all hiding and hunting should not exceed two hours. Discard any eggs that are cracked dirty or that have been out of refrigeration more than the two hours. (Sorry about repeating the two-hour rule, but it's important.)

Throwing out eggs that have been used for decorations or for hiding is much cheaper and easier than

someone getting very ill. Consider buying colorful plastic eggs and putting jelly-beans or little trinkets inside to hide around the house or yard or for decorations.

Tips for easy to peel eggs: ■ Buy the eggs a couple weeks before hard-boiling. Keep in the original cartons and refrigerate. Very fresh eggs are hard to peel after hard cooking. An older egg is easier to peel.

■ Peel the hard cooked eggs while they are still warm if making a sandwich or a salad.

■ Tap all the way around with a knife so the shell comes off like webbing.

■ Peel the hard cooked egg under cold running water. Let your imagination run wild using leftover ham and hard cooked eggs.

Serve hot or cold, together or separate. Grind ham and add it to the deviled egg filling, ham salad, or egg salad for sandwiches or served on lettuce, add to a cream sauce and serve over toast or English muffins, or use either one as a garnish.

Both of the foods are versatile, just treat them with care.

Lois Thieleke is a home economist with the Michigan State University Extension Office in Oakland County.

Cruise the Great Lakes at Henry Ford

Diners can tour the Great Lakes region with their taste buds at Henry Ford Community College's annual spring banquet at 5-9 p.m. Saturday, April 3 in the Student and Culinary Arts Center on HFCC's main campus, located at 5101 Evergreen Road in Dearborn.

The S S Henry Ford Captain's Dinner will be hosted by the HFCC's Hospitality

Program. Tickets are \$40 per person and a portion of the ticket price is tax deductible.

Proceeds from the sale of tickets will benefit scholarships for HFCC Hospitality Studies Program students. To purchase tickets or for more information, please call Jeffery Click at 313-845-9651.

During this culinary adventure, diners can sample new and traditional homemade cre-

ations, according to Dennis Konarski, director of HFCC's Hospitality Studies Program.

"This spring banquet offers guests an opportunity to sample various foods from the Great Lakes Region as well as musical entertainment for a very affordable price," said Konarski. "It's an enjoyable way to spend the evening to sample a lot of great dishes and desserts prepared by HFCC's outstanding culinary students as well as chefs from the area's finest restaurant and

hotels." Before dinner, guests will sample appetizers from several food stations set up in the Student and Culinary Arts Center. Chefs from some of Metro Detroit's top restaurants and hotels will prepare their regional specialties.

Then, guests will be treated to a lavish Captain's Dinner in the main dining hall. Two dinner buffets will feature culinary delights from various Great Lakes cities, including Detroit, Toronto, Cleveland, Milwaukee and Chicago.

Sugarloaf Art Fair

300 Fine Artists & Craft Designers

Novi Expo Center • Novi, MI
April 16, 17, 18, 2004

Daily Adult Admission \$6.00
Children Under 12 FREE
Parking FREE Compliments of Sugarloaf Friday, Saturday & Sunday 10-6

For Discount Admission Coupons:
• Visit your local Farmer Jack
• Print them from www.SugarloafCrafts.com
• Call 800-210-9900

Directions: Take I 96 to Exit 162 Turn south on Novi Road. Turn right onto Expo Center Drive. The Expo Center is located one block on the right.

Buy crafts online at www.CraftsOnline.com

Doctor Nagler's Super-Saver Injection Program

LOSE 5-10 POUNDS THIS WEEK
20 POUNDS THIS MONTH

\$199 Enrollment \$65/Week

734.422.8040

• 8 Injections
• Prescription Medication
• Doctor Visit
• No Other Charges

Diet Results.com 16311 Middlebelt
2111 Nagler, N.D. 734.422.8040 Livonia, MI 48154

New Topamax and Zonagran stop sweet and starch cravings

Why Wait Hours in E.R.?

"We're Here When You Need Us"

Offering Your Community:

- Urgent Care for Accidents and Injury
- Adult or Pediatric Services for Illness
- X-ray • EKG • Lab Work
- Vaccinations
- Sports and School Physicals
- On-Site Lab Services for Mono, Strep, Pregnancy, Urinalysis

BCN Accepted Most Insurance Accepted HAP Accepted

Livonia Urgent Care
In the Mission Health Building
37595 W Seven Mile Rd
(at Newburgh)
Livonia
734-542-6100

Woodland Urgent Care
In the Detroit Medical Ctr Bldg
22541 W. Eight Mile Road
(West of Lasher)
Detroit
313-387-8700

Hours: 8 a.m. - 10 p.m. 7 Days a Week 365 Days a Year

The Livonia Stevenson High School Booster Club Presents The...

Spring Spectacular Craft Show

Saturday, March 27, 2004
10:00 am - 4:30 pm
Admission \$2.00

Livonia Stevenson High School
33500 W. Six Mile Road
Approximately 100 crafters
Concessions available • Strollers welcome
For more information call Debby at 248-476-0315

\$1.00 OFF

Mid-Michigan Cat Fanciers

CAT SHOW
March 27-28
Sat. & Sun. • 9:30 - 5:00

Visit our website: www.midmichigancatfanciers.com

at the **NOVI EXPO CENTER**

ADULTS: \$8.00
SENIORS: \$7.00
YOUTH: \$5.00 (5-12yrs)

For more information call: 734-654-2302

43700 Expo Center Drive • Novi

Come Play With Us!

Meadow Brook Theatre

Talking With
By Jane Martin

OPENING MARCH 17 and running through APRIL 11
Ticket Info Call 248-377-3300
Group Discounts 248-370-3316

VISIT US ON OUR WEB SITE AT www.mbltheatre.com

We meet 11 women in Jane Martin's moving play and they all have bizarre experiences. In stunning monologues they bring us into their worlds. A baton twirler, a rodeo rider, a housewife an actress auditioning for a part; these are some of her eccentric characters. Each funny, frightening, and touching, and each is charged with mesmerizing power.

Sponsored By **The Meadow Brook Theatre Guild**

Space provided by The Observer & Eccentric Newspapers

Speak no evil, see no evil, Oakwood takes care of the third

By David N. Madgy, D.O., pediatric ear, nose and throat surgeon

Another purpose of the tube is to maintain the pressure in the middle ear so that it is consistent with the outside air pressure. It protects the middle ear from bacteria and other germs that are in the nose and throat. Infection can occur when the tube fails to perform its job.

Kids have more ear infections because their tubes are smaller more horizontal and straighter than adults. All of these make bacteria more assessable. The tube is less rigid in children and its small opening is easier to obstruct. It is also not uncommon for fluid to be in the ear on a well baby visit.

There are different forms of treatments and management depend

ing on the situation. For infections the utilization of antibiotics are most common. Also topical drops can be inserted into the ear to help relieve the pain. In recent studies and publications the use of antibiotics is being rethought. With the growing resistance to antibiotics research is being done to explore other treatment options.

If an infection or fluid lasts for greater than three months it can become a chronic condition and surgery is then considered. The most common form of surgery is myringotomy and tympanostomy tubes which is quick easy and virtually painless.

Myringotomy is a small incision made on the eardrum. Through

this incision the tympanostomy tubes, which are very tiny are inserted into the eardrum to allow the drainage that the eustachian tubes are not performing. This procedure is very popular and very successful.

Dr Madgy is a board certified otolaryngologist at Oakwood Annapolis Hospital in Wayne and Oakwood Healthcare Center - Canton. He attended both the University of Michigan and the College of Osteopathic Medicine in Iowa. He has just started practicing in western Wayne County and has been in practice for more than 14 years in Clinton Township Detroit and Southfield. For more information or to make an appointment please call 734-454-2710 or visit www.oakwood.org.

GREEK RECIPES

SPANAKOPITA (SPINACH PIE)

2 pounds fresh spinach
1 pound sliced green onions
1 cup extra virgin olive oil
1/4 cup dill
2 thinly sliced leeks
4 eggs
1 pound Greek filo
Greek sea salt or regular salt
fresh ground pepper
1 pound Greek imported feta cheese

Wash the spinach and boil it. Pour spinach in a strainer and strain. Then tear up the spinach in little pieces. Brown the green onions and the leek in a pot using half the olive oil. Turn the burner off and add the eggs, dill, spinach, salt, and pepper. Oil a sheet pan and open the filo sheets across the pan, about 40 percent of the sheets.

Put the spinach combination over the filo and then place the remaining filo sheets over the spinach.

Oil the top and bake in medium (350 °) oven for about 1 hour.

GREEK SALAD

1 head lettuce
2 1/2 sliced tomatoes
1 sliced cucumber
1 sliced green or red pepper
25 Kalamata Greek olives
1 sliced onion
salt pepper oregano
1 cup imported Greek feta cheese

Cut or tear lettuce up and put in a big salad bowl or dish.

Add cucumbers, tomatoes, onions, green peppers, imported Greek feta cheese, and Kalamata olives.

Dressing is the traditional extra virgin olive oil and vinegar. Pour all over the salad.

Mix carefully and serve right away for crisp, traditional Greek taste.

TZATZIKI

2 teaspoons extra virgin olive oil
1/4 cup plain yogurt
1 large cucumber finely chopped
3 cloves garlic minced
4 green onions chopped
1/4 teaspoon vinegar
1/4 teaspoon dill chopped

Begin by peeling the cucumber and removing the seeds. Cut into small chunks and chop finely.

Mix garlic, chopped cucumber chunks, green onions, extra virgin olive oil, vinegar, and dill. Mix in the yogurt.

Put in the refrigerator, cover for 2 1/2 hours. Serve with Greek bread, as an appetizer, or plain.

GREEK TUNA STEAK

6 tuna steaks
1/4 cup basil
1/4 cup dill weed
1/4 cup extra virgin olive oil
1 chopped tomato
1/4 cup minced garlic
3/4 cup crumbled Greek feta cheese

Preheat oven to 350 ° F. Bake tuna for 7 minutes. Mix all other ingredients in a mixing bowl and put into a frying pan. Let simmer for 5 minutes on medium heat. Pour over the tuna steaks and bake for 30 minutes.

GREEK BAKED COD

1/4 cup extra virgin olive oil
3/4 cup crumbled Greek feta cheese
4 tablespoons chopped oregano
4 tablespoons chopped basil
2 cloves minced garlic
1 tablespoon sea salt
1 tablespoon pepper
2 pounds cod fish
1/4 cup freshly squeezed lemons

Preheat oven to 375 ° F. Mix all the ingredients together except

the cod fish. Rinse the cod fish very thoroughly. Place cod fish in a baking pan. Pour lemon over the cod fish. Pour the mixed ingredients over the cod fish. Bake for about 30 minutes, or until it is opaque through the middle.

GYRO SANDWICH

1/4 pounds ground lamb
1/4 cup minced garlic
1 tablespoon ground pepper
1/4 cup oregano
1/4 cup basil
1/4 teaspoon thyme
1/2 tablespoons onion powder
1 teaspoon salt
Greek bread

Preheat broiler or prepare barbecue. Combine ingredients lightly but thoroughly in large bowl. Shape into patties. Bake for 20 minutes on one side and 15 minutes on the other side. Place in Greek bread and enjoy with some yogurt or tzatziki.

GREEK POPCORN

1 cup unpopped popcorn
1/2 cup shredded Greek feta cheese
1/2 cup shredded Greek kasseri cheese
1 tablespoon oregano
1 tablespoon basil
1/4 cup butter

Pop the popcorn in a hot air popper. Put 1/2 of the popcorn in a large bowl. Sprinkle the feta, kasseri, oregano, basil and butter over the popcorn. Repeat for the remaining quarters. (By seasoning every quarter at a time, it keeps the wonderful Greek seasoning taste through the whole batch of Greek popcorn.)

Recipes courtesy of Gregory Zotos of Livonia, from his book *Gregory's Pita Pocket Full of Simple Greek Recipes*, PublishAmerica, Baltimore.

GREECE

FROM PAGE D1

envelope and sent them to a publishing company. They e-mailed me back and they told me that nine out of 10 (book requests), they toss, but that they had selected mine," Zotos said with a smile. "I was honored." Two years after Zotos first decided to pursue his dream of publishing his own cookbook, *Gregory's Pita Pocket Full of Simple Greek Recipes* was published by PublishAmerica. It was distributed to bookstores and markets last month.

ALWAYS ENJOYED FOOD

Zotos has loved Greek food since growing up in Livonia and travelling to Greece with his parents. (He dedicated the book to his mother Cathy, who lives with Zotos, and his father Evangelos, a professor at Wayne State University, and sister Connie, who both died in a car accident in 1979. The book is also dedicated to his grandparents.)

That tragedy was very difficult for the family. It made Zotos work harder, he says, as he had to support his mother as a teenager. "I appreciate things more because I have worked very hard to get them," Zotos said.

Zotos remembers his trips to Greece as a child, and visits to relatives there. He remembers one village, Crete Hania, and the great spinach pie there. Another village had delicious lamb. "The foods were so mouth-watering," Zotos said. "The filo (phyllo) is crispy and tasty, and the spinach grown there is very green. The climate is warm and the air is clean, which helps the spinach."

He developed an appreciation of Greek cooking in the use of extra virgin olive oil, sea salt, red wine and oregano. "I put all these ingredients together and tried to make it real easy," Zotos said.

Zotos includes recipes for Spinach Pie or Spanakopita and Tzatziki, Greek Salad, Saganaki, Greek Flaming Cheese, and his favorite, Greek Popcorn. "I love the popcorn,"



Popular foods and snacks for Greeks include pistachios, spinach pie, Greek salad, Greek bread, tzatziki and peppers, and a special Greek popcorn. Feta cheese and kasseri cheese (foreground) also are enjoyed by Greeks.

Zotos said "That's a real unique one."

BARBECUING

Zotos' enjoyment of cooking began as a teenager, he says, at the barbecue. Today he enjoys steaks, lamb chops, fish and sea bass on the grill.

He likes lamb chops, brushed with extra virgin olive oil and seasoned with dill, oregano, salt and pepper. He barbecues the chops five minutes on one side at a high temperature, then flips the chops, seasons them again, and cooks another five minutes on high. He repeats this process, but lowers the temperature to medium and lengthening the cooking time to eight minutes, for both sides. (Greeks like their meat well done, he says.)

Many of his recipes feature basil, oregano and dill weed. (Zotos likes the way dill flavors fresh foods.)

Extra virgin olive oil and red wine also are characteristically Greek.

Zotos said he worked on the recipes one year, then it took a second year to get it published and in the stores.

How did he decide what recipes to choose for the book?

"They were things I really enjoyed and liked," Zotos said. "I gave them a flair of my own, I'd try it again with another ingredient, then I'd try it with this and try it with that."

And he didn't pay a dollar for his publication, he says. "They (PublishAmerica)

believed in it so much."

He hopes the reading public will enjoy Greek cooking as much as he does.

"I feel Greek cooking is mouth-watering and pure with red wine and extra virgin olive oil," he said. "By having pure ingredients of red wine, basil and oregano, it gives it a real flavor. You use the right amounts of these and you work to prepare them to have just the right amounts. Greek food is just a pure taste."

Zotos' book lists for \$9.95 at PublishAmerica.com, and is also available at Barnes & Noble and Borders bookstores, Hiller's markets and Byrd's House of Choice Meats in Livonia.

You don't have to be a published cookbook author like Gregory Zotos to be featured in the Observer & Eccentric's Taste section.

If you know someone who loves to cook someone who is a culinary talent or who has tremendous recipes who lives in the Observer & Eccentric circulation area let us know about it. Do they like to barbecue? Do they always host holiday meals or occasional get-togethers? What do they prepare and how do they prepare it? We'd like to feature that person in a story for our Taste section. Please write a short summary about that person with a daytime phone number where we can reach them and why you believe they would be a good feature for us. If you have recipes available please send those as well. Send information to Ken Abramczyk, Taste editor, Observer & Eccentric Newspapers, 805 E. Maple, Birmingham, MI 48009 or 36251 Schoolcraft, Livonia, MI 48150.

TASTE CALENDAR

Please submit items at least two weeks in advance of the date it should be published. Send to Ken Abramczyk, Taste editor, Observer & Eccentric Newspapers, 805 E. Maple, Birmingham, 48009 or e-mail kabramczyk@oehomecomm.net.

Schoolcraft College

Enjoy the talents of the staff at Schoolcraft College with culinary seminars offered through the culinary arts department and the college's Continuing Education Services. Among the topics are Classic French Pastry 6 p.m. Thursday, March 25 and Be a Sweet Tart 6 p.m. April 27. For a complete schedule of seminars call

(734) 462-4448 or visit the college's Continuing Education Services building, 18600 Haggerty in Livonia. For information call (734) 462-4448.

Bella Cucina

Bella Cucina of Plymouth instructs cooking classes in the lower level kitchen at Our Lady of Good Counsel church at North Territorial and Beck roads in Plymouth. The next session will give a demonstration on turkey polpettone, porcini mushroom risotto, spinach salad with pancetta and pine nuts and double cheesy garlic bread. The class taught 6:30-9:30 p.m. on Tuesday, March 30, is a hands-on demonstration. Class sizes are limited

to 12 with a cost of \$50 per person and payment due at registration. For information call (734) 455-4232.

Oakland Community College

Enjoy a Grand Culinary Buffet at Oakland Community College presented by OCC's Culinary Studies Institute, 11:15 a.m. - 1 p.m. Sunday, March 28, on the third floor of Building J on the Orchard Ridge Campus in Farmington Hills. The buffet features a great selection of fresh salads, vegetables, potatoes and meats and fish. The dessert table will have pastries, tortes, fians and cookies. Cost is \$8.95 per person. A buffet also is scheduled for April 22. Call (248) 522-3700.

California Expression 2002
Best Buy Winery of the Year
\$6.99 750 ml
Fresh Strawberries & Raspberries, extremely delectable & delightful, finishes crisp & clean, semi-dry

California Ironstone Symphony 2003
Great with fruit & light cheeses
\$6.99 750 ml
Rich ripe aroma of flowers and fresh fruit. The music is crisp, similar to Detritus minor or Beating.

Michigan's Finest

Joe's Specials of the Week!

<p>Fresh California Asparagus \$1.49 lb.</p>	<p>Florida Crisp & Sweet Grape Tomatoes 99¢ lb.</p>	<p>Fresh California Romaine Hearts 2/\$3.00 22 oz. Pkg.</p>
<p>California Extra Fancy Strawberries \$1.69 lb.</p>	<p>A Variety of Spring Flowers are available! Cyclamen, Gardenias & Azaleas to name a few!</p>	<p>California Extra Fancy Strawberries \$7.99 flat</p>
<p>Bright-Colored Tulips, Hyacinths & Daffodils \$5.99 6" Pot</p>	<p>Argentina's Los Cardos Malbec • Syrah • Cabernet Sauvignon 86 pts. Wine Spectator \$9.99 750 ml Rich fruit, well-bodied & well balanced</p>	<p>Colorful Mums \$6.99 6" Pot</p>
<p>Australian Kangaroo Ridge 2002 Chardonnay • Shiraz • Merlot \$5.99 750 ml</p>	<p>Low-Carb Atkins Pints Ice Cream 2/\$5.00 pt. Net 3 Carbs</p>	<p>Michael Pozzan's Annabella 2002 Cabernet Sauvignon \$12.99 750 ml</p>
<p>The Original Brand Popsicle 2/\$3.00 12 Pack Only</p>	<p>Delicious Fudge Bars</p>	<p>The Original Fudgsicle 2/\$3.00 12 Pack Only</p>

Come into Joe's....
This weekend we will be sampling Atkins Pancake Mix & Syrup • Sat & Sun. 10:00 a.m. - 3:00 p.m.
Joe's Produce - Where Quality & Customer Service is #1
Prices Good Through March 28, 2004
Joe's Produce
33152 W. Seven Mile • Livonia, MI 48152
www.joesproduce.com (248) 477-4333

Mortgage Loans

Fifth Third Mortgage

We have a variety of mortgage products that let you purchase, build or refinance on your own terms.

No money down option*
Fast approval with an instant answer
Interest only loans
FHAVA Mortgages

Construction Loans
Reduced loan fees with a one-time closing
Rate protection with a float-down lock
Pay interest-only during construction

WALK IN your local Banking Center and speak to a Mortgage Loan Originator.
CALL 1-866-53-LOANS | VISIT www.53.com

Fifth Third Bank
Working Hard To Be The Only Bank You'll Ever Need®

* Upon qualification. Product subject to change without notice. Fifth Third and Fifth Third Bank are registered service marks of Fifth Third Bancorp. Member FDIC.



OE08100071

To Advertise on this page call your sales representative 517-548-7074

HOMETOWN PROFILE

PAID ADVERTISEMENT

Put money where it counts

Curt Fournier and staff help clients save money by choosing right mortgage

By Candy Parent
DAILY PRESS & ARGUS

What was good for your parents may not be ideal for you. "Times have changed," says Curt Fournier. "We have a different economy than we did 10 years ago."

Curt, a mortgage broker with Premier Mortgage Funding Inc, says things like the Internet stock scandals Sept. 11 and other events have changed the economy. Today's families generally carry more debt, refinance their home every three years and move every seven years. Obtaining a 30-year mortgage is no longer synonymous to today's lifestyles, Curt says. He recommends people look at their mortgage in five-year increments.

Curt enjoys helping people. He hates to see mortgage brokers take unfair advantage of their clients. Instead, Curt wants to teach people how they can build wealth.

"You need to understand your finances," he says.

Many people look to cut corners with lower credit card interest or look for high rates of return on their retirement savings without examining their largest debt — their home. With the right mortgage program, Curt says he can help a client turn their house into an asset rather than a liability.

Curt operates his business differently from other mortgage brokers. He doesn't simply hand them a one-size-fits-all mortgage. Instead, he sits down with each client and asks them about their financial situation, their plans for the future and other information. Then he presents them with four or five mortgage options that will benefit them along with his personal recommendation. After explaining each one to his clients, he recommends they visit their personal financial advisor and then get back with him on the final decision.

"We become friends first," he

says. "I don't want their business if it doesn't benefit them. There are too many people who I could help. I can't waste my time selling someone a mortgage they don't need."

In fact, Curt's desire to help people build their own wealth has led Curt to study for an additional financial license. Soon he will be able to help people with their entire financial package.

"I like to help people eliminate debt as quickly as possible by paying the least amount of interest as possible," he says.

To do that, he invites each client to examine the options available to them. Programs such as an interest-only loan or a short-term ARM can help to free up additional money to get out of debt quickly.

Once a client is free of debt, they can use the equity in their home to invest and make additional funds. These programs can also be used to increase an individual's standard of living. It's just a matter of learning how mortgages work.

and putting the money where it will provide the biggest return.

Take for example, a 30-year mortgage. If a client borrowed \$200,000 at 6.25 percent, over the course of 30 years, they would pay \$443,319 for their house. And a majority of the interest is paid in the first several years of the loan. So, if a client moves or refinances after a few years, they have essentially wasted their money.

Today there are other options that will reduce the amount of interest paid.

and reduce the amount of payments each month. If clients think in five-year increments, they will see a substantial savings on their home.

Numbers are numbers. Curt says, "I am not selling them a mortgage. I am helping them understand how the process works and then the numbers speak for themselves."

Although each situation is different, the only way to see the benefits is to look at an example.

Assume the client is financing a \$200,000 mortgage and

CURT FOURNIER

- Premier Mortgage Funding, Inc is located behind Home Depot in Brighton
- (810) 844-0411 or (866) 932-0832, toll free
- www.PointHome.net
- Hours: 8:30 a.m. to 5:30 p.m. Monday through Friday and 9 a.m. to 2 p.m. Saturday

compare two different mortgages — a five-year ARM at 5.25 percent and a 30-year fixed at 6.25 percent. Each month, the client who chooses the ARM will pay \$127 less than the client who chooses the fixed mortgage.

At the end of five years, the client will have paid the following:

	ARM	FIXED
Interest	\$54,463	\$64,460
Principle	\$15,701	\$13,325

After five years, the client who chooses the ARM will save themselves \$7,620 in monthly payments and \$9,997 in interest and still have more equity in their home than the person who chooses the fixed rate. Of course, this is an example only. Rates change on a daily basis, but the savings would be similar.

And, at the end of the five years, Curt helps the client find another low rate that best fits their situation. By working with returning customers and referrals and by keeping his profit margin low, Curt is often able to refinance without any fees or closing costs.

"I have a different vision than most mortgage brokers," Curt says. "My position is to help consumers save as much as possible. With a long-term loan, the savings aren't realized until the end of the loan and consumers don't stay in houses for 30 years anymore."

"Wealth is built by paying less money to the bank," he says.

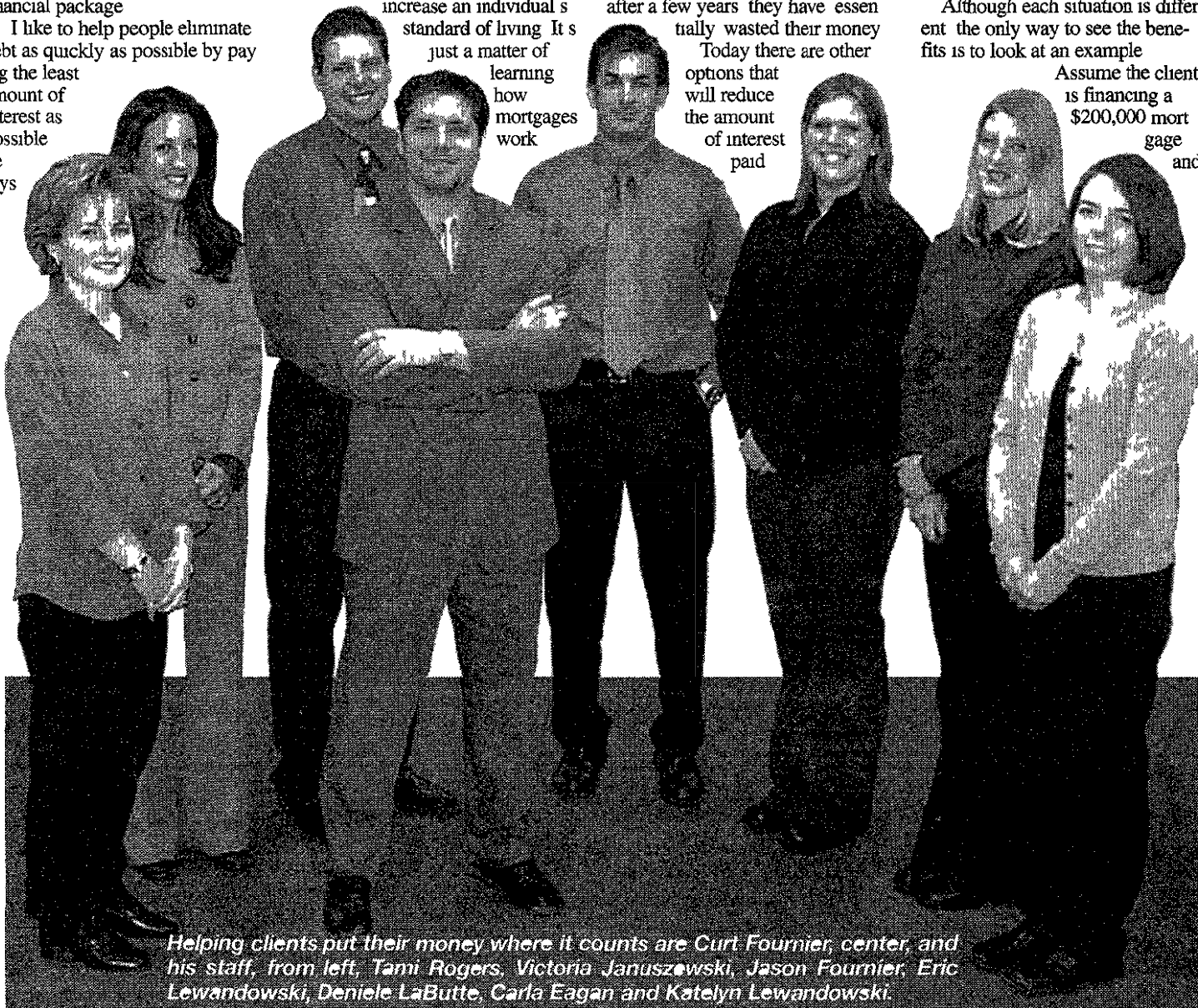

Helping clients put their money where it counts are Curt Fournier, center, and his staff, from left, Tami Rogers, Victoria Januszewski, Jason Fournier, Eric Lewandowski, Deniele LaButte, Carla Eagan and Katelyn Lewandowski.

INTEREST ONLY!

LOW LOW LOW LOW LOW!

Consolidate Debt
Free Up
Cash Flow

100% Financing
on Purchases
& Refinances

MORTGAGE PAYMENTS
CONSOLIDATE ALL YOUR BILLS INTO ONE LOW
PAYMENT W/INTEREST ONLY PAYMENTS

5 Year Fixed

4.5%

4.62% APR

NO POINTS

15 Year Fixed

4.75%

4.879% APR

NO POINTS

30 Year Fixed

5.375%

5.525% APR

NO POINTS

Home Equity Line of Credit

3.75%

NO POINTS

CHECK OUT THESE LOW INTEREST ONLY PAYMENTS

\$150,000
\$200,000
\$300,000
\$500,000

\$468.75
\$625.00
\$937.50
\$1562.50

Based on prime rate 1/4% & 80% LTV (Current prime rate is 4.00)

"Tell everyone what you want
to do and someone will
want to help you do it"

W. Clement Stone

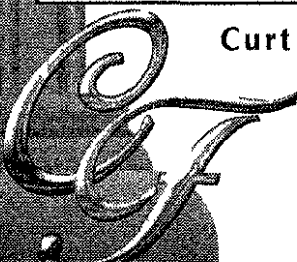

Curt Fournier

HOURS:
Mon. - Fri. 8:30 - 5:30
Sat. 9-2

FREE UP SOME CASH - PAY OFF OR PAY DOWN
HIGH INTEREST CREDIT CARDS

PointHome.net
7927 Nemco Way, Suite #205, Brighton, MI 48116
Call Toll Free (866) 932-0832
or direct at (810) 844-0411

PREMIER
MORTGAGE FUNDING INC





BUSINESS OPPORTUNITY: Profits are always growing! Barbershop for sale — high-traffic location, two chairs, 400 square feet, \$60,000. Get in on a great opportunity now and retire in Barbados later — I am! Call Harry, 000-0000.

There's

trust

in classified advertising!

Newspaper classified advertising is the most reliable source for connecting buyers and sellers.

Whether your newspaper is delivered to your doorstep or your computer, you can always count on your Observer and Eccentric classified section to bring you the best local classifieds around.

In print or online, when you come to The Observer & Eccentric Newspapers, you come to the right place. It's what you trust!

We work for YOU!

For the best in local
classified advertising visit
www.hometownlife.com

Observer & Eccentric

1-800-579-SELL



Real Estate
Inquires

Robert M
Meisner

Mexico offers real estate opportunity

I heard about a colonial city in Mexico by the name of Alamos and I am wondering if you have any information about it in terms of real estate opportunities and North American involvement.

Alamos is a lovely community in central Mexico which has over 250 American residents who have, in most instances, constructed very lovely homes and/or have renovated homes. While it is a primarily agricultural area, many North Americans have settled here and by way of an example, a 2,600-square-foot home is listed for \$350,000 furnished. The city is quaint and the real estate market seems to be strong and you have full ownership of the property that you purchase. You are best advised, of course, to consult a local Realtor who will no doubt speak English.

I have heard about a resort area in Mexico called San Carlos and I am wondering if you know whether there are any residential developments and/or resorts for investment purposes.

San Carlos is a lovely community on the Sea of Cortez which is burgeoning with condominium and time share development. A number of the hotels have vacation club opportunities and there are a number of condominium developments. The harbor is picturesque and there are a number of Americans who have settled there witnessed by a number of American restaurants and substantial English signage throughout the area. There are a number of opportunities for investment and you are best advised to consult with a local Realtor concerning your interest in the area.

Robert M. Meisner is a lawyer and the author of *Condominium Operation: Getting Started & Staying on the Right Track* second edition. It is available for \$9.95 plus \$2 shipping and handling. For more information call (248) 644 4433 or visit bmeisner@mich.com. This column should not be construed as legal advice.

View the
Observer &
Eccentric Real
Estate Classifieds
on the Web:

www.hometownlife.com



Pam Dover (center) of Coldwell Banker Schwitzer in Birmingham reviews recent home for sale listings with Pete McAteer and Ladonna Deer. Dover works to match good value with what buyers want.

Working together: Buyer's agent can help you find your dream home

BY NORMAN PRADY
CORRESPONDENT

"Oh, look. There's a for-sale sign. Write down the phone number. And there's another one."

"Laura said we should drive by the house for sale near her." "That's on the other side of town. Do we want to go that far?"

Well, do you? Do you want to go to the other side of town? Are you content to drive around for hours writing down phone numbers?

Is this the best way to find a house to buy? Or do you think you might want to ask a real estate professional to be your buyer agent? If so, will you know how to work with the agent? Here are some suggestions of what your tasks could be.

Vincent M. Brennan, sales agent, Remerica Realty Professionals, Farmington Hills.

"Establish the relationship as long-term."

"Understand the conditions of the arrangement and then stick with that agent even though you're not financially obligated."

"It's about loyalty and trust."

HOW MUCH CAN YOU AFFORD?

David Cartwright, Riverpointe Realty Walker & Associates, Southfield.

"Before you contact an agent, talk with mortgage people to determine what you can afford. They will give you a pre-approval certificate up to a certain dollar value. That way, when you go in to see an agent, it's clear what you can afford."

and you're not wasting anyone's time.

"Be sure of the area you want to look in. Define the house you want to buy - that will fit the family's needs."

Lynn DeJohn, Quality Properties GMAC Real Estate, Plymouth.

"The buyer agent needs to know who's involved in the buying process. Are husband and wife the buyers or are you going to continually throughout the process seek the advice of friends, neighbors and countrymen who are not in the real estate market today?"

"If you're talking with parents who haven't bought a home in 20 or 30 years and they come to see the home you've picked out after eliminating 32 ugly properties, they're not going to have a clue as to the value of that home. But if your parents are going to give you money, we need to get them involved early in the process."

GET PRE-QUALIFIED

Pam Dover, Coldwell Banker Schwitzer, Birmingham.

"Get pre-qualified by a reputable lender."

"Be open to work within the parameters of what you want and what you can spend."

"Know what you're looking for."

"I work to match good value with what buyers want and I've had to talk some of them out of houses that I thought weren't right for them. A lot of it comes with women's intuition. They can become enamored with a kitchen or decor,

but I see a broader picture. Listen to the agent's objective view."

Brian M. Duggan, American Classic Realty, Livonia.

"Be loyal to the agent, who's looking out for the buyers' interests."

Laura Knuth, Knuth & Associates, Garden City.

"It's the No. 1 thing we say. Remember that the buyer doesn't pay us directly."

"If you do look around on your own, call us on anything that looks interesting. See us as your source of information."

Darlene Larsen, Cranbrook Associates, Bloomfield Hills.

"Get pre-approved for a mortgage. And be prepared to give earnest money - a good-faith deposit - with an offer on a house."

Tom Mines, Century 21 Sakmar & Associates, Rochester.

"In current market practices, sellers only want to spend their time considering offers from people they know can afford their homes. Pre-approval is first and foremost these days. Sellers don't want to negotiate with buyers who turn out to be unable to buy."

"Have a clear idea of what area you want to live in. Some people aren't really sure and ramble from one place to another being indecisive. Consider proximity to work, family, friends, schools."

"Consider lifestyle. Are you an urban person? A country person? Deal with practicalities."

"Understand what distance means to daily life and don't be trapped in some fantasy."

"Consider the condition of the home, especially a structur-

SOURCES

■ Vincent M. Brennan
Remerica Realty Professionals
(248) 476-5300

■ David Cartwright
Riverpointe Realty Walker & Associates (248) 354-1500

■ Lynn DeJohn, Quality Properties GMAC Real Estate (734) 451-5400

■ Pam Dover, Coldwell Banker Schwitzer (248) 642-2400

■ Brian M. Duggan, American Classic Realty (734) 591-1900

■ Laura Knuth, Knuth & Associates (734) 261-0920

■ Darlene Larsen, Cranbrook Associates (248) 647-0100

■ Tom Mines, Century 21 Sakmar & Associates (248) 652-7700

■ Carey Wilhelm, Wilhelm & Associates (248) 625-9500

al issue. Don't love the house despite the defect if it doesn't fit what you've been shopping for. Unless you're sure you have the ability and funds to deal with it.

"Take a reality check." Carey Wilhelm, Wilhelm & Associates, Clarkston.

"Tell your agent the truth. If you tell me what you want and I work to find it and then you say it's not what you want."

Mortgage rates dip, one-year ARM at lowest level on record

BY MARTIN CRUTSINGER
ASSOCIATED PRESS

Mortgage rates fell again with the benchmark 30-year mortgages approaching last year's rates, which were the lowest in more than four decades. Rates for one-year

adjustable mortgages set a new record low.

The average rate on 30-year, fixed-rate mortgages dipped to 5.38 percent, mortgage giant Freddie Mac reported March 18 in its weekly nationwide survey of mortgage rates.

This week's rate was down from 5.41 percent last week

and marked the lowest level for 30-year mortgages since the week ending June 27, when rates averaged 5.24 percent. The low point for 30-year mortgages since the early 1960s was 5.21 percent, reached in mid-June of last year.

"Mortgage rates this week are barely above the generational low levels we saw in June of last year," said Frank Nothaft, chief economist at Freddie Mac. "We are currently predicting that this will fuel yet another record year for total home sales."

Mortgage Bits

Tim 'Timbo' Phillips



Invest in real estate wisely

As our weather finally warms, "House for Sale" signs are sprouting up in pace with the tulips. It is a wonderful time of the year for us all, but perhaps more so for real estate investors.

These next few weeks may be "prime time" for investors looking to snatch up some early season real estate specials. The number of homes for sale is rising steadily, but the warm weather buyers have yet to start swarming.

Investing in real estate is very much like buying a home in which you would live. The most notable exception includes putting a 10 percent down payment on your purchase if you wish to secure your best interest rates and terms. You may sometimes get away with less down than that with some lending sources, but you will likely get "beaten up" on terms.

DOWN PAYMENT

You can get your down payment from just about anywhere - like your existing home's equity - as long as you can verify the source of the your funds. If you do not have a down payment, you may need a "silent partner." This type of investor provides the money required to fund the real estate investments, while you do the rest of the work. In turn, you both share property's income and appreciation.

Real estate investors categorically pay slightly higher interest rates than do buyers who actually live in the purchased properties. To compensate for the higher interest rates and to preserve their cash flow, many investors opt for the better pricing of shorter-term mortgages - like three- or five-year adjustable-rate mortgages.

You will get your cheapest mortgage money by purchasing your real estate investments as individuals, not through your company or corporation. Doing so using the latter methods will require a more expensive and restrictive commercial loan instead of a residential mortgage.

You will do well to get direction from your asset advisor, your attorney, and your mortgage lender on how to best structure your investment deals. Hitting the market with solid advice and a qualified funding source should make your hunting experience that much more fun and profitable.

Timothy J. Phillips is a mortgage broker and newspaper columnist. You may access his archives in The Wealth Academy at www.PhillipsHQ.com or you may phone him toll free at (866) 369 4516. Homebuyers should always consult a professional for guidance specific to their situation.

JUMBO LOAN of the WEEK



10-YEAR INTEREST ONLY
Call for details
Keith H. Lewis
248-901-1700

LEWIS FINANCIAL GROUP LLC
Mortgage Banking • Downtown Birmingham

HOME of The WEEK



Plymouth's Woodlore North!

A priceless private wooded setting frames this feature filled Woodlore North gem that gives you so much more than what you expect! Wonderful oak kitchen with hardwood floor & newer Corian counters, tile splash & premium appliances. Kitchen & Casual Dining area open to the family room & a Skylit sunroom. Finished lower level. 4 spacious bedrooms. 1st floor study. 3 1/2 baths. 3 car garage. Dual HVAC systems. Preview via virtual tour at www.gladchun.com. Very attractively priced at \$549,900.

Call Mike & Mary Gladchun
RE/MAX on the trail 734.459.1234

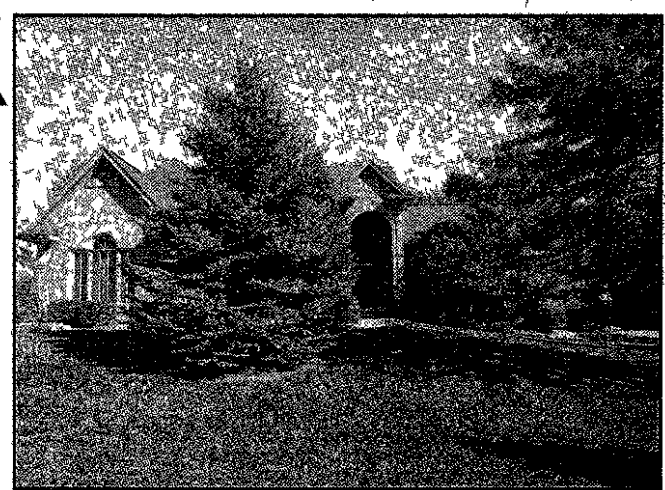

These are the Observer & Eccentric area residential real estate closings recorded the weeks of Nov 10 14 at the Wayne County Register of Deeds office Listed below are cities addresses and sales prices

7561 Andover \$462,000	1926 Cedar Valley \$200,000	42126 Cherrylawn \$220,000	1569 E Lakeview \$179,000	Garden City	15724 Green Lane \$165,000
7025 Ardley \$170,000	1962 Cedar Valley \$169,000	48065 Chesterfield \$365,000	2121 E Roundtable \$198,000	31542 Barton \$154,000	31545 Haldane \$190,000
42284 Ashbury \$227,000	1998 Cedar Valley \$178,000	44989 Coachman \$185,000	7208 Emerson \$195,000	29114 Bock \$225,000	10040 Hambleton \$186,000
43993 Bannockburn \$226,000	1475 Centennial \$160,000	1438 Colonade \$180,000	192 Essex \$195,000	31520 Cambridge \$248,000	14039 Harrison \$188,000
40483 Bay Harbor \$173,000	1501 Centenn al \$205,000	1460 Colonade \$164,000	45127 Fa r Oaks \$248,000	210 C a r \$267,000	15136 Harrison \$157,000
41643 Bedford \$167,000	1526 Centenn al \$165,000	1461 Colonade \$208,000	6756 Foxcreek \$267,000	32522 Hennepin \$269,000	8937 Harvey \$172,000
5831 Castlegate \$325,000	1624 Centenn al \$195,000	1483 Colonade \$180,000	7067 Foxr dge \$269,000	6312 Henry Ruff \$248,000	15145 Hubbard \$170,000
48409 Castleside \$450,000	1697 Centennial \$160,000	377 Cornell \$255,000	46036 Gainsborough \$248,000	7091 Hubbard \$258,000	19470 Ingram \$187,000
48547 Castles de \$410,000	1698 Centennial \$150,000	1703 Crestview \$288,000	46528 Hanford \$258,000	250 Lathers \$372,000	36287 Jamison \$220,000
1836 Cedar Valley \$172,000	609 Cherry Orchard \$226,000	39427 Dorchester \$340,000	47010 Hidden River \$420,000	1115 Lathers \$99,000	8930 Livinle \$177,000
1854 Cedar Valley \$156,000	622 Cherry Orchard \$232,000	7671 E Claymore \$233,000	47021 Hidden River \$339,000	415 Lytle \$299,000	19702 Liverpool \$376,000
			47031 Hidden R ver \$339,000	29445 Sheridan \$160,000	13969 Lyons \$164,000
			39697 H llary \$167,000	Livonia	11019 Mayfield \$183,000
			402 Hunters \$157,000	28014 Six Mile Road \$160,000	17710 Mayfield \$249,000
			8126 Hyann s \$466,000	36800 Seven Mile Road \$324,000	14124 Merr man \$167,000
			4050 K mber y \$222,000	33665 Eight Mile Road \$97,000	16561 Middlebelt \$75,000
			46081 Larchmont \$341,000	36648 Angelme \$160,000	29390 Munger \$195,000
			1408 Ledgewood \$229,000	31801 Balmoral \$370,000	30554 Munger \$120,000
			42813 Lilley Pointe \$123,000	8883 Beatr ce \$152,000	17492 Myron \$297,000
			6621 N Lambeth \$320,000	14254 Blue Skies \$208,000	15631 Oak \$45,000
			45681 N Stonewood \$209,000	31600 Bobr ch \$180,000	32954 Oakley \$223,000
			45731 N Stonewood \$203,000	14336 Brentwood \$210,000	39030 Parkhurst \$230,000
			474 N Willard \$239,000	31763 Bretton \$170,000	16591 Penn \$250,000
			238 Nassau \$210,000	34771 Bridge \$345,000	16453 Pollyanna \$220,000
			47614 Pavilion \$355,000	17177 Brookstew \$75,000	29561 Puritan \$262,000
			42022 Pocatello \$268,000	17204 Carol \$280,000	20301 Purlingbrook \$188,000
			42023 Pocatello \$318,000	17239 Carol \$179,000	14375 Ramblewood \$209,000
			3078 River Meadow \$261,000	8966 Cavell \$236,000	19644 Rensellor \$118,000
			1944 Roundtable \$195,000	14147 Caveti \$222,000	14050 Richfield \$235,000
			6241 Runnymede \$201,000	11853 Chase \$235,000	35427 Richland \$170,000
			4537 S Sheldon \$237,000	28518 Cleveland \$144,000	31739 Scone \$190,000
			44273 S Umberland \$244,000	9840 Cranston \$210,000	15509 Shadyside \$270,000
			8610 Sandpiper \$260,000	9907 Cranston \$225,000	16118 Southampton \$265,000
			42669 Somerset \$204,000	13998 Cranston \$240,000	14460 Stonehouse \$218,000
			41187 Southw nd \$122,000	18400 Doris \$195,000	38343 Summers \$220,000
			339 Springfield \$381,000	27430 Dover \$212,000	15583 Sussex \$254,000
			2775 Stanton \$470,000	15926 Eilen \$284,000	18009 University Park \$155,000
			43299 Stonington \$257,000	28491 Elmira \$158,000	35495 W Chicago \$185,000
			48585 Times Square \$108,000	33353 Fargo \$73,000	29043 Westfield \$150,000
			49388 Townsend \$155,000	16880 Farmington \$176,000	14929 Yale \$155,000
			1458 Trad ton \$205,000	16884 Farm ngton \$182,000	
			1590 Trad ton \$293,000	16888 Farm ngton \$192,000	Plymouth
			2071 Vme Way \$138,000	16892 Farmington \$184,000	11928 Appletree \$300,000
			39747 Wales \$210,000	16894 Farmington \$228,000	46731 Barr ngton \$336,000
			41131 Westfield \$238,000	16896 Farmington \$185,000	12425 Beacon Hill \$392,000
			44173 Westminster Way \$208,000	17010 Farmington \$208,000	249 Blunk \$330,000
			43779 Yorktown \$187,000	9290 Flor da \$149,000	357 Blunk \$418,000
					1696 Cassidy Place \$235,000

www.DetroitMortgages.com

MORTGAGE RATE UPDATE

TERM	RATE	PTS	LOCK	FEES	APR	TERM	RATE	PTS	LOCK	FEES	APR	TERM	RATE	PTS	LOCK	FEES	APR
GROUP ONE MORTGAGE CO. Stuart P Daniels 5/1 Arm 4.125 0.00 30day \$350 4.27apr 3/1 Arm 3.875 0.00 30day \$350 3.92apr Website: Stuart.Grouponemortgage.com 800-436-1452 (pg)																	
FIRST INTERNATIONAL MTGE. 30yr Fix 5.25 0.00 30day Call 5.97apr 15yr Fix 4.50 0.00 30day Call 4.62apr 3/1 Arm 3.625 0.00 30day Call 3.75apr 248-540-1065																	
NORTHLAWN FINANCIAL 30yr Fix 5.125 0.00 30day \$300 5.19apr 3/1 Arm 3.25 0.00 30day \$300 3.63apr 5/1 Arm 3.75 0.00 30day \$300 4.04apr Option Arm 1.25% 3.34apr 248-988-8488																	
GOLDEN RULE MORTGAGE 30yr Fix 4.750 1.75 30day 0.00 4.97apr 15yr Fix 4.000 1.50 30day 0.00 4.38apr 5/1 Arm 3.125 1.00 30day 0.00 3.25apr No Application Fee / Ask About Interest Only 800-784-1074																	
DIRECT MORTGAGE FUNDING Call 866-487-7399 Rates as low as 1.28% 30yr Fix 5.25 0.00 30day Low 5.48apr 3/1 Arm 3.00 0.00 30day Low 3.23apr 15yr Fix 4.625 0.00 30day Low 4.86apr 5yr Arm 1.25 0.00 30day Low 4.06apr																	
HOME FINANCE OF AMERICA 30yr Fix 5.125 0.00 30day \$295 5.22apr 15yr Fix 4.50 0.00 30day \$295 4.86apr Open Sat. & Sun. 9-9 www.hifinance.com 800-358-5626																	
AMERIPLUS MORTGAGE CORP. 30yr Fix 5.25 0.00 30day \$400 5.29apr 20yr Fix 4.875 0.00 30day \$400 4.93apr 15yr Fix 4.50 0.125 30day \$400 4.59apr 10yr Fix 4.25 0.125 30day \$400 4.35apr 5/25 Bal 4.00 0.00 30day \$400 4.03apr ASK FOR A NO COST QUOTE PURCHASE RATES EVEN LOWER Sun. Applications Available 248-740-2323																	
NORTHWESTERN FINANCIAL All Types of Credit Accepted • CASH FAST TO PAY OFF BILLS & TAXES • BANKRUPTCY (Current / Prior) • SELF EMPLOYED / NO INCOME VERIFICATION • NO COST EQUITY LINES • ZERO DOWN PROGRAMS 800-292-7768																	
AMERICAN FIRST RATE 30yr Fix 5.25 0.00 45day \$350 5.31apr 15yr Fix 4.625 0.00 45day \$350 4.71apr 3/1 Arm 3.375 0.00 50day \$350 3.41apr Imperfect Credit O.K. With Equity www.loansurvey.com 800-887-9106																	
1ST METROPOLITAN MORTGAGE IF YOUR PAYMENTS ARE GREATER THAN \$125,000 \$18.82 per month \$250,000 \$34.87 per month \$175,000 \$24.59 per month \$350,000 \$46.12 per month You Need To Call Us Now 866-586-9553 Payment rate based on 2.975 apr zero points 30day lock																	
LENDERS - TO PARTICIPATE, CALL 1-800-736-1305 www.DetroitMortgages.com																	

Rates/terms/apr current as of 3/22/04 may change without notice or vary depend ng on loan s ze Source Midwest Mortgage Monitor #Credit report/appra sal APR based on \$150 000 loan amount 15 day prepaid nt

HOME LOAN EXPERTS

LOOKING TO BUY A HOME? WE'LL HAVE TO SAY "NO."

No points. No fees. No problem.

- For home purchase or refinance
- Flexible approval process
- Fixed and adjustable rate mortgages available

For a home loan with zero hassles, give us a call.

(248) 374-4501

Washington Mutual

HOME LOANS

17909 Haggerty Rd. • Northville, MI 48167

Programs subject to change. Certain restrictions apply. Borrower Pre-Approval subject to acceptable property/approval. Reduced points/fees. Interest rate/APR will be higher than when closing costs are paid by you. We have loan offices and accept applications in Washington Mutual Bank FA and Washington Mutual Home Loans Inc. many states Washington Mutual Bank ID OR UT WA and Washington Mutual Bank fsb ID MET UT

feeling at home WEIR, MANUEL, SNYDER & RANKE REALTORS

PLYMOUTH
Ice Cream parlors coffee shops community events all just a few blocks walk away in prestigious Hough Park Gourmet kitchen three new baths reflect the present white coved ceilings hardwood floors cherry library preserve the past
734-455-6000 EP40 LI 24025042 \$649,000

SALEM
What ever your lifestyle this home is for you 2.2 wooded acres is only minutes from town Professionally finished lower level w/pub-like bar and game room including furniture finish built-ins, TV & aquarium
734-455-6000 EP85SA24019979 \$488,000

CANTON
Beautiful 3100 sq ft home w/open floor plan just move in and enjoy the 3 season room deck or patio overlooking landscaped yd backing to commons! Walking distance to parks library & community center
734-455-6000 EP12GL24021891 \$429,900

PLYMOUTH
Ranch home located in township close to down town lower taxes. Good sized fenced lot, above ground pool windows replaced in 95 Extra insulation in attic & walls Partially finished basement. All appliances stay
734-455-6000 EP10 BA 24028357 \$224,900

CANTON
Great Sunflower location by pool/tennis courts/club house & park. Spacious floor plan 3 huge bedrooms 2 baths, family room & den Fireplace in living room off kitchen Treed lot with flower gardens
734-455-6000 EP75GA24022344 \$243,900

WESTLAND
Lovely 3 bedroom brick ranch with updates galore and more to come. This home has been selected by the Wayne County Airport authority for complete soundproofing. That translates to 'NEW!!!'
734-455-6000 EP01K-24022738 \$129,900

734-455-6000
500 South Main St., south of Ann Arbor Trail
VIEW NEARLY 50,000 LISTINGS AT www.weirmanuel.com

Quality PROPERTIES INC.

1365 S. Main, Plymouth
or Visit us on the web...
www.qualitypropertiesGMAC.com
(734) 451-5400

GMAC Real Estate
PREMIER SERVICE

Trusted Advisor
Skilled Negotiator
Expert Facilitator
service you deserve. People you trust.

CANTON
BEAUTIFUL CANTON COLONIAL. Glenegry colonial stunning 4 bedroom 2.5 bath classic! Fnde of ownership is reflected throughout!
\$387,900 (P77MID)

CANTON
FAIRWAYS AT PHEASANT RUN SUB
Fantastic 4 BR 3 500 sq ft colonial Gourmet kitchen 2 way flpc 2 story GR & foyer Hldwd & ceramic flrs Fin bsmt den huge mstr ste w/ luxurious bath Prem cul-de-sac lot Brck paver w/elec awning \$459,900 (P51SAN)

NORTHVILLE
GORGEOUS CAPE COD One year new home featuring premium wooded lot cherry cab nets & vaulted ceilings Must see proceed to sell at
\$419,890 (P02CYP)

PLYMOUTH
ARBOR VILLAGE RANCH Spacious 3 bdrm brck ranch 1.5 bath family room w/flpc Finished bsmt 2 car attached garage All appliances stay!
\$219,000 (P72ORA)

PLYMOUTH
RIDGEWOOD HILLS COLONIAL Featured in Parade of Homes! Professional decor inside & out. Four bedrooms 2 1/2 baths four-season room master suite with r/w master bath built in glassed bookcases surround fireplace (SOPRED)
\$419,900

PLYMOUTH
PRIDE OF OWNERSHIP! 4 bdrm colonial w/ finished walkout bsmt Formal LR DR den and FR w/vaulted ceiling gas flpc Sunroom w/slyght Walkout has adrded bar gas flpc entertainment center and pool table Lge deck paver walkways 3 car site entry garage
\$469,900 (P85STD)

FARMINGTON HILLS
GORGEOUS 3 BDRM, 2.5 BATH RANCH Spacious kit w/extra cabs FR w/hat flpc w/health & mantel cer baths 1st flr cry full bsmt New w/h to all apps freshly painted Updated roof sec sys sprinklers patio 2 car attached garage
\$299,900 (P29CAM)

CANTON
COLONIAL IN FOREST TRAILS SUB Great family colonal featuring 3 lg bdrms 1.5 baths open floor plan hldwd flrs fresh paint new roof & windows and much more!
\$249,900 (P10FOR)

FARMINGTON
WHY RENT WHEN YOU CAN OWN! Beautifully updated 3 bdrm ranch is ready to move into Updates include windows vinyl siding roof kitchen bath C/A and more!
\$134,900 (P55HAW)

PLYMOUTH
ARBOR VILLAGE RANCH Spacious 3 bdrm brck ranch 1.5 bath family room w/flpc Finished basement 2 car attached garage All appliances stay!
\$219,000 (P72ORA)

PUTNAM TWP.
LIVE EVERYDAY LIKE YOU'RE ON VACATION 3 bdrm 2.5 bath 2 story colonial on 1 acre, built in 1997 Backs to Portage Lake (access chain of lakes) private beach and dock area 1 lot down
\$349,000 (P67LAN)

YPSILANTI
MOVE-IN CONDITION! This 3 BR 1.5 bath brck ranch has been completely redone in 1988 Updates incl oak kt w/breakfast bar newer carpet hldwd in 3 BRs tear-off roof (7 years) vinyl wnd C/A freshly painted
\$169,900 (P67TYL)

BRIEFS

Real Estate Briefs features news and notes on professional associations, office activities, upcoming meetings and seminars, new services/products and consumer publications. Write: Real Estate Briefs, Attn: Keely Kaleski, Observer & Eccentric Newspapers, 805 E. Maple, Birmingham, MI 48009. Our fax number is (248) 644-1314. Our e-mail address is kkaleski@oe.hometown.com.

Parade of homes

The exhibition of 115 new model homes throughout southeastern Michigan continues through April 18. Models can be viewed during open house tours or online at www.builders.org. An exhibition of photos and floor plans of the homes will be on display at the Spring Home and Garden Show, April 2-4 at the Novi Expo Center. Hours are noon to 9 p.m. Friday, April 2; 10 a.m. to 9 p.m. Saturday, April 3; and 10 a.m. to 6 p.m. Sunday, April 4. Tickets: \$9 adults, \$7 senior citizens, children under 12 admitted free.

Homebuyer workshop

Free home buyer class offered 7-9 p.m. Tuesday, March 30 by Rosemary Firestone of RE/MAX 100 Inc. and her financial team at First Michigan Title, Six Mile Road at 1275 in Livonia. No charge, but reservations are required. Call (734) 420-9600 or e-mail info@firestone-team.com. Learn how to avoid the biggest mistakes you can make when buying a home, how to choose a buyer's agent, about new government loan programs, financing, and other related topics.

Architecture

James Stewart Polshek 6 p.m. Thursday, April 1, Lawrence Technological

University 21000 W 10 Mile Road, Room A 200 Architecture Auditorium, Southfield. No charge. Call (248) 204-2880 for information.

Career night

Hosted by Century 21 Hartford, 7 p.m. Wednesday, March 31, 32726 Grand River, downtown Farmington. You'll receive all the necessary information to begin a career in real estate. To register, call (248) 478-6000.

Seminar

Learn how to purchase a house at this free seminar, 7-8:30 p.m. Tuesday, April 6, at Baldwin Public Library, 300 W. Merrill, Birmingham, one block south of Maple, one block east of Southfield Road. Sponsored by Chase Manhattan Mortgage Corp. No charge. Call (248) 649-1062, ext. 246 for information.

Condo class

Nationally known condominium attorney and columnist Robert M. Meisner of Meisner & Associates, an adjunct professor of community association law at Detroit College of Law at Michigan State University and Cooley Law School, is teaching a course, "Advanced Condominium Operation: The Essentials for Success," 7-9 p.m. Tuesdays, April 27 to May 18, at the Bingham III Office Park, 30200 Telegraph, Suite 467, Bingham Farms. Sponsored by Oakland Community College. The cost is \$95 per attendee. For more information, call (248) 522-3618 or Meisner & Associates PC at (248) 644-4433.

How to Buy Your First Home

Free Seminar Sponsored by Approved Mortgages, Inc.

Buy a home for as little as \$500 down!

100% financing programs are now available

- Can I qualify for a mortgage?
- How much home can I afford?
- How much money do I need for the down payment?
- Is my credit okay?

Wednesday, March 31 • 7:00-8:30pm
46000 Summit Parkway • Canton
For Reservations Call Eileen McDonnell
734-455-2219 ext. 244

Brett J. Phillips | Eileen McDonnell
 Century 21 Today, Inc. | Approved Mortgages

Quality GMAC Real Estate
 37699 Six Mile (Suite 200), Livonia
 (734) 462-3000

FARMINGTON HILLS Just listed exquisite Copperwood East ranch! This 2,900 sq. ft. offers 3 bedrooms, library, 2 1/2 baths, crown moldings, oversized kitchen w/cherry cabinets, formal dining, spacious great room w/marble surround fireplace, paver patio and walks w/lush landscaping. MUST SEE! \$549,900 (D02Tur)

GARDEN CITY COOL OFF THIS SUMMER in the 30' diameter above ground pool while enjoying the large fenced 80x130 ft. lot. The home offers 3 bedrooms w/many updates, no windows, roof shingles, furnace, hot water heater, glass block entry doors, etc. box etc. A large 21x24 garage & lots of parking tops it off! \$149,900 (L40Jam)

FARMINGTON NOTHING TO DO BUT move into this Farmington charmer! You'll love the new ceramic bath & exquisite kitchen w/abundance of counters, cabinets plus a 3x7 walk in pantry. Updated windows, roof, A/C, furnace, sliding carpet, plumbing etc. All this and award winning landscaping too! \$149,900 (L09Vic)

DEARBORN HTS LOVE & CARE are the trademarks of this exceptionally maintained 3 BR ranch in fabulous Golfview Manor Sub. Hardwood floors thruout, gorgeous kitchen w/oak cabinets & new appliances, 1 full & 2 half baths, new architectural shingles, new gutters & partially finished basement. \$179,900 (L51Hi)

DEARBORN HTS Absolutely spotless brick bungalow w/great curb appeal, good neighborhood & great price! Lots of character w/wet plaster, cove ceilings, hardwood under most carpet & loads of storage. Finished basement, alum trim, 2 car garage, newer windows, plumbing, ext. doors & more + Home Warranty. \$129,900 (D66Gra)

REDFORD READY & WAITING! This 1,550 sq. ft. bungalow is on a quiet tree lined street w/a 200' ft. deep fenced lot. Its many features include master bedroom w/half bath & sitting rm (study), large living room, dining room, beautiful Florida kitchen w/table space, a full partially finished basement. GREAT HOME for the money! \$147,900 (L85Nor)

ROYAL OAK SIMPLY CHARMING & full of character, this 3 bedroom bungalow has a gas fireplace w/mantle in the LR, hardwood floors, wet plaster, 16x10 heated sun room overlooking 8 ft. inground pool & double lot. Enjoy the finished basement w/half bath & office or 4th bedroom w/walk in closets. Lots of updates! \$210,900 (L10Ale)

REDFORD EXCEPTIONAL VALUE! Spacious well maintained 3 bedroom brick ranch located in S Redford's most desirable area! Neutral décor & well appointed. Newer windows, furnace, C/A & newer doors & finished basement w/wet bar, 4th bedroom/office, large FR workshop, etc. \$159,900 (L40Sem)

Novi Meadowbrook Townhomes Condominiums

Conveniently located South of 13 Mile Road West off Meadowbrook Road. Easy Access to M-5 and Twelve Oaks Mall.

Affordable Pricing Starting at \$229,900

Offering 12 distinct two story floor plans, a few with first floor master suites, 2 & 3 bedroom plans, ceramic baths, 9 ft ceilings on main floor, first and second floor laundry rooms, full private basement with rough plumbing for bath, some daylight and walkout sites, 2 car garages, volume ceilings, walkout paths, and low maintenance fee Walled Lake Schools.

INCLUDED IN PRICE

- Electric Range
- 21 cu. ft. Refrigerator
- Microwave • Dishwasher • Disposal
- Central Air
- Deck (200 Series Units Only)
- Hardwood Floors in Kitchen and Nook (100 Series Units Only)
- Rough Plumbing in Basement-3 piece (buildings 16, 18, 19, & 21 Only)

For additional information call 248-549-6900 • Brokers Welcome
 Model Hours are Saturday & Sunday 12:00-5:00 pm.
 Weekdays 1:00-5:00 pm (Closed Thursday)
 www.meadowbrooktownhomes.info
 or e-mail jstockton1@aol.com

Read Observer Sports for prep coverage

COLDWELL BANKER PREFERRED, REALTORS®

<p>BRICK CAPE COD Within walking distance to downtown Home has been professionally painted t/o. Both baths have been updated to perfection. 4 BRs w/hwd floors. Good size LR, formal DR, FR, updated kit w/granite c tops & Pergo floor. Beautiful fenced yard & 2 car garage. \$374,900 (402AN)</p>	<p>MORE FOR THE MONEY In this 2 bedroom 2.5 bath condo. Full finished basement, 1 car attached garage, oak kitchen w/Corian countertops, fireplace in FR, deck, immaculate condition. End unit ranch. A must see! \$177,900 (527MA)</p>	<p>BEAUTIFUL WALKOUT SITE Located in the popular Winds Sub. Updates: fresh paint t/o, refinished deck & fencing, new furnace in 03, refinished cabinets in kit, bath kit flooring. Really nice 2 bedroom 1.5 bath condo w/partially finished bsmt w/bonus room. Great location! \$133,900 (154SO)</p>	<p>CORDIAL HOME IN THE BEST OF TASTE 4 BR Colonial in a tree lined setting within easy access to shops & recreation. Formal living and dining rooms, den w/handsome hwd floors & recessed lighting. Spacious FR features cathedral ceilings & natural flc. Freshly painted & ready for immediate occu! \$319,900 (903JU)</p>	<p>DOESN'T GET BETTER THAN THIS! N of 5 Mile W of Levan. Livonia 3 bedroom ranch w/an inground pool on a quiet low traffic street. New roof in 01, new furnace and A/C in 99, updated main bath w/whirlpool tub, FR w/fplc, 2 car garage, part finished basement. \$214,000 (626CO)</p>	<p>DOWNTOWN LIVING A much sought after 3 story condo has just gone on the market. 2 bedrooms, 1 bath and a 2 car garage! Just a short walk to concerts, ice show, art fairs, parades and farmer's market. Specialty shopping galore! \$194,900 (392AN)</p>	<p>SOUTH LYON ACRES Private country living on 5+ acres. This South Lyon ranch offers 3 BR, 2 baths, a large great room and a cozy fireplace in an additional LR. 30x40 pole barn with 220 electric. Private setting yet close to the city. \$289,500 (332SU)</p>
<p>4 BEDROOM BRICK So many updates! New vinyl siding & windows, hardwood floors & 2 car garage & 1st floor laundry. Immediate occupancy! \$129,900 (501DE)</p>	<p>GREAT LOCATION Good things come in big packages too! Over 2,600 sq ft colonial in a great location in a great neighborhood. 4 bedrooms, 2.5 baths, 1st floor den w/closet. Major updates inside and out. \$329,900 (376PA)</p>	<p>PICTURE PERFECT! Don't miss this immaculate & completely updated colonial in Deer Creek Sub. Foyer w/hwd & circular staircase, FR w/cathedral ceiling & fpic. Formal DR. Outstanding lower level w/oak wet bar, custom cabinetry, office and bath. \$624,900 (217DE)</p>	<p>SALEM ESTATE HOME With over 3,000 sq ft situated on 5 lovely acres of land with a pond, 4 bedrooms, 3.5 baths, formal living and dining, finished walkout with great room & game room, Dream kitchen and an ultra lux master with hot tub. An absolute must see! \$599,800 (171FI)</p>	<p>GOLF COURSE COMMUNITY 2 BR, 2.5 BA and unit in outstanding condition. Both bedrooms have private baths. Great room w/fireplace, dual door entry, study, large kitchen w/most appliances & pantry. Dining room with new Andersen doorwall to the deck. Professionally finished daylight basement. \$278,900 (329BR)</p>	<p>LIVONIA RANCH Gleaming hardwood floors, updated baths and kitchen. Finished basement, 2 1/2 car garage, fenced yard, 3 bedrooms and 1 1/2 baths. Very clean. Central air! \$176,000 (239CA)</p>	<p>NORTHVILLE CONDO Great opportunity to own. Two bedroom 1.5 bath condo features a natural fireplace in the living room, offers a deck and a partly finished lower level. All appliances stay. Excellent location close to the clubhouse, pool & the beach. Large bedrooms. \$149,900 (290NO)</p>
<p>WHY RENT! Updates include brand new roof, 04 Hardwood floors, freshly painted t/o, newer windows, updated kitchen & bath, 2 car garage & 1st floor laundry. Immediate occupancy! \$129,900 (501DE)</p>	<p>WOODED WALKOUT SITE Plymouth's Westbnr Village. Classic colonial boasts formal LR & DR, den eat in kitchen, FR w/fplc, 1st floor laundry, finished w/o lower level w/work room, Private master suite w/bath & WIC, 3 tiered deck & a patio. \$339,000 (356RO)</p>	<p>THIS IS PLYMOUTH A 1913 built charmer with a FR & mstr BR addition in 1991. The kit, HVAC, electrical & plumbing are all updated as well. 3 bedrooms, 2 full baths, screened front porch, paver walkways, garden shed, quaint outbuilding & just steps from downtown Plymouth. \$411,000 (670FO)</p>	<p>DREAMS DO COME TRUE! Cape Cod with 2,796 sq ft of living space! 4 BRs and 2.5 baths with w/o bsmt for add'l room. Beautiful GR w/cathedral ceilings, huge kitchen, 1st floor master side entry, garage, professional landscaping and so much more! \$359,900 (887PA)</p>	<p>CURB APPEAL PLUS A fantastic location in South Lyon within walking distance to the downtown area. 3 bedrooms, 2 full baths, first class brick ranch. Formal living & dining, finished basement with wet bar and fireplace. Situated on a country sized lot. \$234,500 (580CH)</p>	<p>HERE IT IS! 4 BRs and 2.5 baths. Beautifully done w/a freshly painted interior and new carpet. Rich hardwood & gleaming ceramic floors, vaulted ceilings, skylights, cedar deck and more. Home is on a premium wooded lot w/nice landscaping & sprinkler system. \$299,900 (670CO)</p>	<p>NORTHVILLE'S POPULAR HIGHLAND LAKES! Spacious condo backs to a commons & close to elementary. 2 huge bedrooms with Jack & Jill bath. Formal living room & family room w/fireplace, finished basement, updated windows & baths, freshly painted kitchen w/appliances & Pergo floor. \$160,900 (955SC)</p>

All Real Estate Companies are not the same. DISCOVER THE DIFFERENCE. PROFESSIONALISM • SATISFACTION • RESULTS.

Visit us on our Web Site... www.cbpreferred.com

MORTGAGE FINANCING

We'll beat any lender's price, or pay you \$250* Guaranteed loan decision the same day you apply or we pay you \$250.

1-888-895-2536 Toll Free

COLDWELL BANKER MORTGAGE

NORTHVILLE/NOVI (248) 305-6090	CANTON (734) 392-6000	FARMINGTON (248) 478-6022	WESTLAND/GARDEN CITY (734) 392-6000	PLYMOUTH (734) 459-6000	LIVONIA (734) 425-6060
--	---------------------------------	-------------------------------------	---	-----------------------------------	----------------------------------

COLDWELL BANKER SCHWEITZER REAL ESTATE

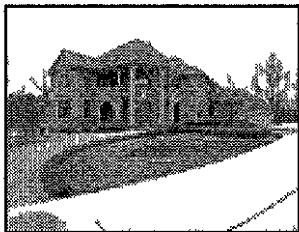

SUPERIOR \$2,500,000
World Class Residence! 9+ acres w/ pond & woods 1st flr mstr ste w/lg wic & jacuzzi tub w/waterfall Granite tops in both kits French drs to 5 balconies Add 10 acres available for \$250,000 (OEP31ANN) 888-870-9127 7043825



NORTHVILLE \$849,900
Exceptionally Appointed Executive Home! Low traffic interior setting Gorgeous gourmet kit w/granite cntrtops 2 story FR Custom staircase bannisters Custom tile work in bathrooms New inground pool (OEP05MER) 888-870-9127 7111654



FARMINGTON HILLS \$675,000
Finished Lower Level Walkout W/ in law Suite 2 Story Entry Formal Dining Living & Library Gourmet Kitchen Mstr Ste! One Of A Kind Hillside Beauty Offers A New Flagstone Patio & Cedar Deck For Entertaining (OEN85HAR) 888-870-9123



FARMINGTON HILLS \$609,900
3 1/2 Bath Cape Cod! 1st Flr Mstr Ste W/cathedral Ceiling Jacuzzi & Shower Gr W/soaring Ceiling & Fp Kit W/granite Counters & All New Appl's Ceramic Tile In Foyer & Kit 3 1/2 Car Garage 2 Decks Patio Sprinklers (OEN24EAG) 888-870-9123



PLYMOUTH \$559,900
Truly Spectacular! 4BR 3 1/2 BA Colonial on picturesque 1/2+ acre lot New in 2001 kitchen w/Conan cntrtops Spacious GR w/FP Prof fin walkout w/spa b/i bar FP & add 1634 sq ft living space (OEP28LEB) 888-870-9127 7111757



PLYMOUTH \$549,900
Stately Colonial! This home has it all with the perfect blend of sophistication & comfort Gracious foyer w/HDWD fir & crown molding Elegant kit w/granite cntrs & large island (OEP98FOX) 888-870-9127

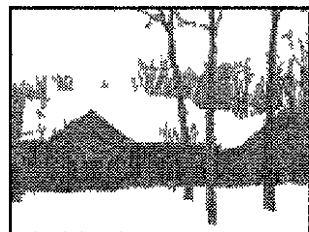

PLYMOUTH \$549,000
Beautiful 1 Acre Wooded Lot! Well maintained & updated Open floor plan w/granite countertops hardwood floors Casement windows ceramic tile recessed lights Finished basement w/ possible 2 bedrooms (OEP00BET) 888-870-9127



PLYMOUTH \$497,500
New construction on small lake w/ stonecast FP cherry cabinets granite countertops Custom mids & trim Brazilian hardwood floors Ceramic BA & laundry 4BR 2 1/2 BA daylight bsmt (OEP78IR) 888-870-9127



PLYMOUTH \$489,000
Squeaky Clean Cape Cod Great Rm w/nat FP 1st flr Mstr BR WIC lux bath w/jetted tub Kit w/oak cabs solid surface cntrtops spacious nook opens to 4 Season Rm Fin LL w/full BA & storage 3 car gar (OEP76DEE) 888-870-9127



LIVONIA \$440,500
Updates include Newer Furnace & C/a Windows Roof (tear Off) Flooring Hwh Carpet Wet Bar In Fr & Fin Bsmt Inground Pool Neutral T/o Move in Condition All Data Approx Immed Occ (OEN36BR) 888-870-9123

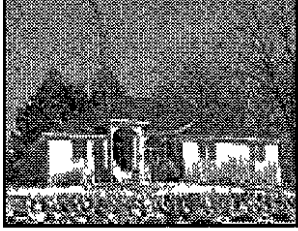

MILFORD \$389,000
Walk Out Ranch Gorgeous 1996 custom home on 12 acres offers 2847 ft & 1100 sq ft Fin bsmt 4BR 3BA Great Rm w/FP Master suite Huge 2 car gar Neutral decor Florida Room (OEP33ANN) 888-870-9127



CANTON \$379,900
2 story Foyer Hardwood Floors Kitchen W/center Island Walk In Pantry & Glass Cabinet Drs 3 Season Rm Master Bdrm W/ 2way Fireplace (OEN54WOO) 888-870-9123



SALEM \$365,000
Classic 4 bedroom 2 bath Colonial on 2+ acres in Salem Neutral decor Home warranty Basement Surrounded by open spaces and terrific views Great family home! (OESLY965M) 888-870-9131

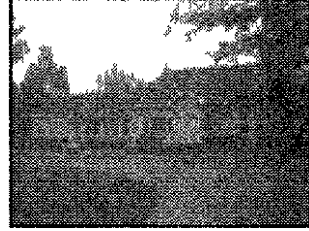

CANTON \$359,900
17 Acres In Canton 4 Br 2 1/2 Ba Stunning 1st Floor Mstr Ste Updates Inc Windows Elec Roof Kit W/oak Cabinets All Baths Bright Sun Room Brick Paver Patio Frshly Painted T/O Newer Carpeting (OEL10GYD) 888-870-9105

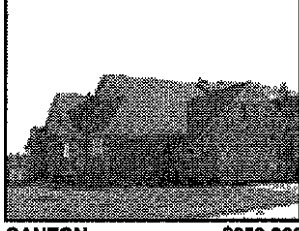

CANTON \$359,900
Links West Condo End unit ranch condo Spectacular views of golf course Oak flrs in kit nook & foyer Oak cnts in kit Custom handmade mantle over gas FP Master w/jetted tub Corp excu (OEP05CLE) 888-870-9127



BRIGHTON \$820,000
Custom built traditional Colonial w/4 bedrooms 5 full baths prof finished trm & moldings t/o all season sunroom 3 frplcs 33x15 country kitchen with hearth room inground pool 3+ car garage Lot next door can also be purchased (OEL35URB) 888-870-9105



CANTON \$337,500
This One is Sharp! Truly move in condition 4BR 2 1/2 BA Colonial on an oversized interior lot New in 2003 kitchen with built in appl's FR w/FP Luxry master ste w/ fashion bath Must see (OEP79SOR) 888-870-9127



CANTON \$293,500
Wow! This One Will Knock Your Socks Off! Gorgeous Pulte Ranch W/ Upgrades Galore & Great Open Flr Plan Decorator Perfect & Clean As A Whistle T/o Fabulous Prof Fin Bsmt W/ Library/office (OEN67PON) 888-870-9123



LIVONIA \$285,000
Clean & Neat 4 Bedrm 2 1/2 Bath Double Wing Brick Colonial Nice Family Rm W/fireplace & Door Wall To Large Concrete Patio Fantastic Tread Lot Full Bsmt 2 Car Att Garage 1 Yr Home Warranty (OEL74ELL) 888-870-9105



LIVONIA \$279,000
Impressive Colonial move-in Cond Foyer Opens To Formal DR & GR W/ bncked Hearth updated Kitchen Fully Auto In grnd Gated Heated Pool With Deck W/gazebo lavish Landscape & Sprnkir Sys Lg Mstr Bdrm (OEL12BLO) 888-870-9105



CANTON \$259,900
Sellers Have Reduced To The Price By \$27,000 To Less Than What This Unit Cost New & Tens Of Thousands Less Than It Would Cost To Duplicate Because They Want An Immediate Sale (OEN21CHE) 888-870-9123



FARMINGTON \$250,000
Updated Ranch W/add bdrm & Full Bath In Bsmt Oversized Deck Vaulted Fam Rm Opens To Updated Kit w/granite Tops & Skylight Hwf Coved Ceilings (OEN17OAK) 888-870-9123



PLYMOUTH \$249,900
Cute 3 BR 2 BA Bungalow Spacious master bedroom w/ master bath Living Rm w/ hardwood floors & coved ceiling Updated kit 02 new CA 02 new roof 01 Award winning landscaping (OEP25ART) 888-870-9127



PLYMOUTH \$239,900
Dtown Plymouth Home W/ All The Updates furnace Roof Refinished Hdwd flrs Vaulted FR & DR Updated Kitchen W/ Built In China Cabinet & Stainless Pro Series Appl Storage Area 2 Car Garage (OEL10VIF) 888-870-9105



SOUTH LYON \$237,000
Beautiful condo with open floor plan Basement is finished with family room and large workroom/storage area First floor master and laundry Good buy (OESLY07EVE) 888-870-9131



WIXOM \$229,900
Raised Ranch Located In Wixom s Indian Wells Updates Inc Carpet Paint Ceramic Tile In Foyer Bath Ktn C/A & Bkyd Fence 1998 Bkt 2 1/2 Car Gar W/lg 2nd Story Storage (OEL13WEN) 888-870-9105



BELLEVILLE \$224,900
Family home w/4bdrms & 2 baths Living room w/vaulted ceilings & fireplace Hardwood flrs in kitchen & breakfast nook LL w/bdrm & bath Lrg corner lot w/sprinklers (OESLY40PRE) 888-870-9131



LIVONIA \$204,900
Completely Updated 3 Bedrm 1 1/2 Bath Brick Colonial Kitchen W/ newer Oak Cabs Cntrs Flooring & All Appls LR W/fireplace Full Fin Bsmt Updates Inc Roof Vinyl Wind & Siding Elect Bath Furnace (OEL33YAL) 888-870-9105



PLYMOUTH \$200,000
Ceramic Tile Foyer Kitchen W/ downwall To Patio Spacious Living Rm Finished Lower Level W/built in Storage 2 1/2 Car Attached Garage Central Air Fabulous Cul de sac Location For Privacy! (OEN49SP) 888-870-9123 7057242



PLYMOUTH \$199,900
Choice location Close to expressways and shopping Beautiful newer kitchen and baths Large sunroom off back and large lot Updates roof windows C A siding appliances Great open floor plan (OESLY72BRE) 888-870-9131



LIVONIA \$186,000
This Well Maintained Home Has A 12x14 Three-season Room Most Of The Flooring On The Entry Level Is Hardwood The Mstr Bdrm Has An Entrance To The Full Bath There Is A Second Kitchen In The Finished Basement (OEN21BRE) 888-870-9123

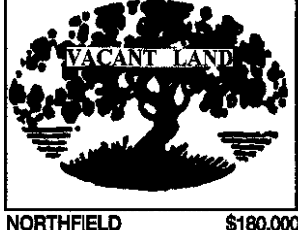

NORTHFIELD \$180,000
Splits subject to township approval Gorgeous new development in Northfield township perked surveyed and private road just in building plans subject to developer and by laws Land contract available (OESLY00AVE) 888-870-9131



FARMINGTON HILLS \$169,900
Charming Home On Quiet Street Beautiful Fenced Double Lot Pella French Doors Open To Rear Deck Family Room May Be Used For First Floor Bedroom (OEL24JAC) 888-870-9105 7109473



LIVONIA \$162,900
3 Bdrm Brick Ranch In Livonia LR W/lrg Pict Win Updated Kit W/oak Cabinets Sink Counters & Flng Updates Bath Fixt Neut Carpet T/o Vinyl Windows Furnace Copper Plumbing Gls Blk Wind Elect (OEL90HAT) 888-870-9105



SOUTH LYON \$154,900
Quant 2 bedroom sun filled bungalow Great starter home! Spacious kitchen Florida room neutral decor Central air Fenced yard 1 car garage Walking distance to downtown Home warranty (OESLY39LIB) 888-870-9131



BEVERLY HILLS \$149,900
New Maple Cabinets Counters & Hdwd Floor In Updated Kitchen 1 1/2 Car Garage All Appliances Birmingham Schools Note 4% Comm Tremendous Value Immediate Occupancy (OEN26KIF) 888-870-9123



WESTLAND \$144,900
3 Bedroom Brick Ranch W/New Vinyl Siding Perfectly Located On A Low Traffic Cul de sac! FR Central Air Oak Cabinets In Kitchen First Floor Laundry Room & 2 Car Detached Garage Large Backyard & All Appliances (OEL48HUN) 888-870-9105

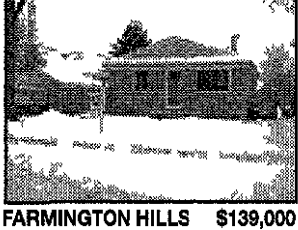

FARMINGTON HILLS \$139,000
Move right into your new home Newer roof updated kitchen and finished basement Landscaped yard with privacy fence Very clean home (OESLY09COL) 888-870-9131

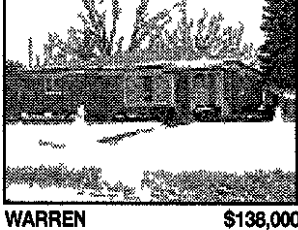

WARREN \$138,000
Updated Brck Ranch Offers private Secluded Patio Updates Include Roof Refinished Hdwd Floors In Lr & Dr Newer Kitchen Cabinets & Flooring Some Newer Windows Front Door Finished Bsmt W/2nd Bath 2 Car Garage (OEN85CUN) 888-870-9123

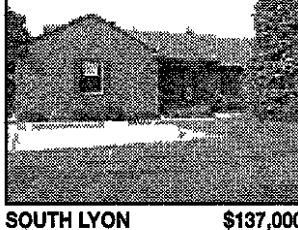

SOUTH LYON \$137,000
55+ Adult co op Immaculate 1st floor has large oak kitchen formal dining Florida room + patio Finished LL w/family rm bath + guest rm Lake privileges clubhouse + activities (OESLY79CAM) 888-870-9131



DEARBORN HEIGHTS \$133,900
2 Bedroom can Be Easily Back To 3 Bdrm Updates Include Roof Glass Block Windows In Bsmt Furnace W/a/c Prep Vinyl Siding On Garage (oversized 2 1/2) Fresh Interior Paint One Year Home Warranty Hurry! (OEN00211) 888-870-9123

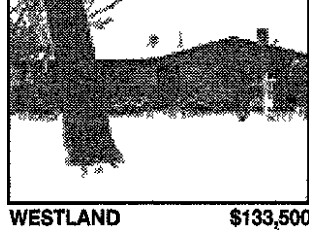

WESTLAND \$133,500
Nice 3 Bedroom Brick Ranch Open Floor Plan Updated Kitchen W/island Updated Bath Neut Decor Newer Wind Roof Doorwall To Lg Pato Full Wall Driftstone Nat Frpl In LR All Appl Lg Fenced yard (OEL41FER) 888-870-9105



DEARBORN HEIGHTS \$124,900
Gorgeous ranch in school district 7 Presently 2 bdrm can be converted back to 3 You will love open floor plan Completely updated and fresh! Screened in porch Too many updates to mention (OESLY57CLI) 888-870-9131



SALEM \$124,900
Prime location perfect for country estate 2 1/2 acres natural gas & electricity on property recent perk Ready to build! Just bring your plans All data D/M approx (OESLY007M) 888-870-9131

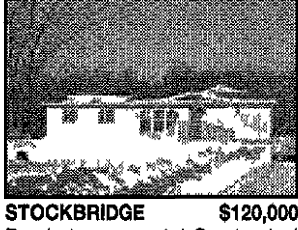

STOCKBRIDGE \$120,000
Ready to move into! Great value! This 4 bedroom ranch offers 1828 sq ft and 3/4 acre Newer windows drywall well, furnace roof newer deck with great view! (OESLY00CHA) 888-870-9131



BERKLEY \$154,900
Craftsmanship & condition makes this house a 10! Updates include kitchen newer carpet t/o copper plumbing fresh paint t/o all appliances 1st floor laundry/utility w/built in storage covered front porch 2- car garage (OEL73WIL) 888-870-9105



LIVONIA \$113,900
Newer Brick Construction With Large Living Room Open To Kitchen And Dining Room Spacious Master Bedroom Has Large Walk in Closet Home Has Private Entrance Carport And Immediate Occupancy (OEN08CLA) 888-870-9123

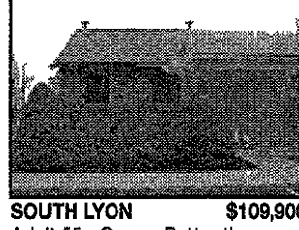

SOUTH LYON \$109,900
Adult 55+ Co op Better than new Lovely end unit Beautifully maintained Open and light kitchen All appliances stay LL offers familyroom w/fireplace bed rm/office and full bath Clubhouse and pool (OESLY05CON) 888-870-9131



PLYMOUTH \$157,900
Affordable! Great opportunity to live in Plymouth New carpet remodeled bath Quiet neighborhood Appliances remain Large garage Nice lot Pleasant 14x8 enclosed front porch (OEP 83Oak)

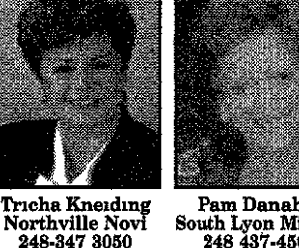

Tricha Kneading Northville Novi 248-347-3050

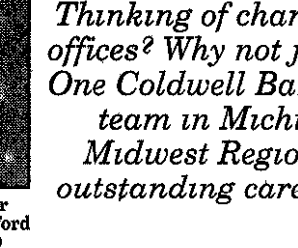

Pam Danaher South Lyon MI 248-437-4500

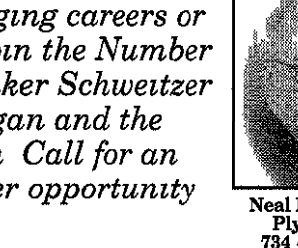

Neal Lanphear Plymouth 734-453-6800



Dave Owens Livonia 734-691-0393

Thinking of changing careers or offices? Why not join the Number One Coldwell Banker Schweitzer team in Michigan and the Midwest Region Call for an outstanding career opportunity

Phone In, Move In .

- A same day mortgage decision or we'll pay you \$250*
- To meet your requested closing date or we'll reduce your interest rate by 1/8th of one percent for the life of the loan*
- To beat any lender's price GUARANTEED or pay you \$500**

1-888-767-8615

*Approved conventional purchase loans only **Subject to verification of lender's price and other restrictions



Livonia Office - 734-591-0333 • Northville Office - 248-347-3050
• Plymouth - 734-453-6800 • South Lyon 248-437-4500

Ann Arbor • Birmingham • Clarkston • Bloomfield Hills • Farmington Hills/W. Bloomfield • Grosse Pointe Hill • Grosse Pointe Woods • Lakes • Livonia • The Macomb Center • Northville • Plymouth • South Lyon • Troy

060195814

All ads run online
FREE! A value of
up to \$87.00



Observer & Eccentric

Classified

Ask about
our NEW
**HOT LINK
SERVICE**
www.hometownlife.com

0001-2450
**Home & Service
Guide**

3000-3890
**Real Estate
For Sale**

3890-3980
**Commercial
Industrial**

4000-4980
**Real Estate
Rent/Lease**

5000-5980
**Employment
Instruction Services**

6000-6980
Announcements

7000-7780
Merchandise

7110-7130
**Garage and
Moving Sale**

7800-7980
**Animals
Pets/Livestock**

8000-8780
**Automotive
Recreational Vehicles**

Place your ad toll free at
1-800-579-SELL



Walk-In Office Hours: Monday - Friday 8:30 am - 5:00 pm
Publication Day: SUNDAY PAPER.....5:00PM Friday
Deadline: THURSDAY PAPER.....5:30PM Tuesday
Fax your ad: 734-953-2232



Too Late To Classifieds...

If you missed our regular Tuesday deadline for Thursday's publication, you can now call us 'til Wednesday at 11am and place your ad in our "Too Late To Classified" Section.
Look for this to appear in Section C of the paper!
Let us work for you!

On-line at www.hometownlife.com • E-Mail Us: oads@oe.homecomm.net

**3000's
Real Estate**

3000	Homes	3405	Stockbridge Unadilla Gregory
3030	Open Houses	3410	Troy
3040	Ann Arbor	3415	Union Lake
3043	Auburn Hills	3420	Walpole Lake
3045	Belleville & Van Buren	3423	Waterford
3050	Birmingham Bloomfield	3424	Wayne
3055	Bloomfield	3430	Webberville
3060	Brighton	3440	West Bloomfield
3070	Byron	3420	Walpole Lake
3080	Canton	3423	Waterford
3090	Clarkston	3424	Wayne
3100	Cohasset	3430	Webberville
3110	Dearborn	3440	West Bloomfield
3115	Dearborn Hgts	3445	Westland
3120	Detroit	3450	White Lake
3130	Chelsea	3460	Whitmore Lake
3135	Dexter	3470	Williamston
3140	Farmington	3480	West-Commerce
3145	Farmington Hills	3490	Ypsilanti
3150	Farmington Hills	3500	Genesee County
3155	Ferrisville	3510	Ingham County
3160	Florenceville	3515	Lapeer County
3170	Garden City	3520	Livingston County
3180	Grosse Pointe	3530	Mecomb County
3190	Hamburg	3540	Oakland County
3200	Highland	3550	Shiawassee County
3210	Highland	3560	Washtenaw County
3220	Holly	3570	Wayne County
3230	Howell	3580	Lakefront/Waterfront Homes
3234	Huntington Woods	3590	Other Suburban Homes
3235	Keego Harbor	3600	Out of State Homes/Property
3236	Lake Orion	3610	Country Homes
3238	Lathrup Village	3630	Farms/Horse Farms
3240	Linden	3640	Real Estate Services
3250	Livonia	3700	New Home Bu Iders
3260	Miford	3710	Apartments For Sale
3265	Monroe	3720	Condos
3270	New Hudson	3730	Duplexes & Townhouses
3280	Northville	3740	Manufactured Homes
3290	Novi	3750	Mob Homes
3300	Oak Grove	3755	Commercial/Retail For Sale
3305	Oak Park	3760	Homes Under Construction
3310	Orion Township	3770	Lakefront Property
3315	Orchard Lake	3780	Lakes & River Resort Property
3318	Oxford	3790	Northern Property
3320	Perry	3800	Resort & Vacation Property
3340	Plymouth	3810	Southern Property
3345	Pleasant Ridge	3820	Lots & Acreage/Vacant
3347	Plymouth	3830	Time Share
3350	Redford	3840	Leases/Option To Buy
3360	Rochester	3850	Mortgage/Land Contracts
3370	Royal Oak	3860	Money To Loan
3380	Salem Salem Township	3870	Real Estate Wanted
3390	Southfield Lathrup	3880	Cemetery Lots
3400	South Lyon	3890	Commercial/Industrial For Sale

Open Houses 3030

Farmington Hills
OPEN SAT & SUN 1-4
35689 Fredencksburg 4 Bed colonial \$293 000
CHRISTINA (248) 910-2842
KELLER WILLIAMS REALTY
5775 W Maple W Bloomfield
W Bloomfield school! Buyers agent welcome Open Sun 1 4 \$379 900 248 681 8022

FARMINGTON HILLS OPEN SUN 2-5
22430 Haynes 9 Mile / Grand River area 2 bedroom ranch 2 car attached garage 727-424 4537

Garden City
OPEN SUN 12 3
103 GILMAN
N of Cherry Hill between Inkster & Middlebelt 3 Bed brick ranch A/C appliances w/ oversized garage partially finished bsmt w/ 1/2 bath and fireplace
PRICED TO SELL AT \$134 926
PAUL KLEBBA (734) 718 1811
KELLER WILLIAMS REALTY
22260 Haggerty Rd Northville

Howell Open Every Sun 1 4
2661 Thistlewood Dr Very clean 1999 ranch 1450 sq ft 3 bed 2 bath nice family sub Garden tub vaulted ceilings \$184 900 Bring all offers! 517 545 0844

LIVONIA OPEN SUNDAY 1 5
38727 Grandon
N of Joy W off Hix
Very updated brick ranch with 1370 square feet six rooms three bedrooms and two first floor baths Updates includes kitchen main bath furnace/air Andersen Windows gas fireplace and all interior doors 2 car attached garage Asking \$218 900 734 542 7161

LIVONIA SUN 1 4
Rosedale Gardens 3 bed/1.5 bath 1600 sq ft colonial Double lot 11309 Arden Ave \$244 900 734 266 3180

NOVI BY OWNER OPEN SUN 1 4
Meadowbrook Glen Sub 42335 Parkridge 3 bedroom ranch 1.5 baths many updates Finished bsmt 12x20 deck Secluded back yard Exc cond \$122 500 248 348 3622

NOVI Open Sun 1 4
45262 Yorkshire Dr in Jamestowne Green sub 91 built 4 Bed 2.5 bath 2100 sf colonial Great lot great house immaculate Visit www.hno.com id#17573 for more info \$348 500

Open Houses 3030

W BLOOMFIELD 2630 sq ft 4 bed 2.5 bath dining room family room 9 ceilings 2 story foyer large kitchen vaulted master ste 2nd floor laundry c/a 2 tier patio w/walkway professional landscape w/sprinkler system W Bloomfield school! Buyers agent welcome Open Sun 1 4 \$379 900 248 681 8022

WAYNE Open Sat 3/27 1 5 3 bed bungalow updates remodel kitchen/bath garage A/C \$128 500 734 641 7646

WESTLAND Open Sun 1 4
214 Marigold Circle
Cherry Hill W of Newburgh 2 bed 2 bath w/attached garage appliances included \$142 500 734 721 2535

Westland
OPEN SUNDAY 1-4
Lovely updated 3 bed ranch Finished bsmt New Kitchen bath furnace A/C 2+ Garage & more Surrounded by Exp ensive homes Only \$146 900 Easy to own 00 Down Cherry Hill S on Wildwood W on Glen 34422 Glen
Call Real Estate Professionals Recorded Message 888 857 8787 Ext 72334

WIXOM OPEN SUN 1 6
1914 PALMER DR
N/Charms E/Wixom Rd Lake Access All Sports
2400 sq ft colonial built in 96 Open floor plan 4 bed 2 1/2 baths kitchen w/nook dining room living room family room/fireplace full basement central air 3 car attached garage stone patio \$309 000 248 926 1771

Ann Arbor 3040
OPEN SUN 2-4
7523 Warren NE Ann Arbor Spectacular! Top of the line amenities in this new 5 bed 4 1/2 bath with finished walkout on 5 17 wooded & landscaped acres Ready for move in \$999 999 Plymouth Rd to Curtis to Warren to Lone Oak lane #2401426 Julie Picknell 734-429 9449 evs 734 395 8383
Charles Reinhardt Co Realtors

Bloomfield 3055
BY OWNER Fox Hills 2650 sq ft new gourmet kitchen new wood floors new carpeting new upper level 4 bed 3 baths \$350 000 248 338 0717 www.owners.com/amt4634

Brighton 3060
BRIGHTON/HOWELL 1800 sq ft homes on 1/2 acre lots Great location paved streets sidewalks sewers golf & boating Builders closeout hurry only 6 lots left \$180 000 \$220 000 Liberty Homes 810 225 8944

Cherry Hill Village Area
Gain equity from your neighbors This 3 bedroom 2 bath 1700 sq ft home is nestled on 1+ wooded acre in an area of new homes selling for \$450K Updated inside and out! \$239 000 By owner 734 997 4007 734 927 0717

COLONIAL 2000 sq ft 4 bed 2 1/2 bath totally updated in lovely Mc Intyre Sub \$235 000 734 844 2133

GREAT NEIGHBORHOOD
1700 sq ft colonial 3Bed 1.5 Bath New roof/carpet fenced yard Great room w/cathedral ceiling/gas fireplace \$234 900 Home warranty incl Must see! (734) 904 2011

NEW LISTING
Spacious Sunflower Colonial with 4 bedrooms 3 1/2 baths family room w/fireplace formal dining & living rooms 1st floor laundry professional finished bsmt w/rec room & office large two tiered deck & gazebo Quick occupancy 1 Yr warranty \$294 900
ROGER & SUE DAVIS
Coldwell Banker Preferred (734)392 6022

A word to the wise when looking for a great deal check the Observer & Eccentric Classifieds!

Clarkston 3090
CLARKSTON
Autumn Shore Lake community custom 4 bed 3100 sq ft + finished bsmt extras include granite stainless steel alarm prof landscape & stone patio Backs up to Natural area great neighborhood \$504 000 8416 Peaceful Valley (248) 922 5829

EXCLUSIVE 4 bedroom 2 5 bath Colonial 3 5 car 2462 sq ft Large private lot \$339 900 By owner Open Sun 1 3pm 5155 Glenwood Creek 248 393 1423

OPEN SAT & SUN 12 5 pm 2
large bed 1 bath finished bsmt w/gas fireplace c/a all appliances stay extra large deck large corner lot \$149 900 22205 Madison 313 274 5314

HUD HOME!
5 bedroom 2 bath for only \$3500 For listings (fee) 800 719 3001 ext 1091

Farmington 3140
FARMINGTON
3 bedroom 1 bath brick/alu minium ranch Asking \$150 000 \$700 moves you in Special financing avail 24 hr free recorded message 888 544 4036 x 9013

Farmington Hills 3145
BEAUTIFUL VIEWS 3 bed brick ranch 2 bath full bsmt 2 fire places large 2 5 car garage on 2 5+ acres Prestigious area Heavily wooded Golf course Large stream By apt By owner \$425 000 (248) 210 3845 Also available two 3 5+ acre lots part of family farm separately owned all together approx 10 acres

Farmington Hills 3145
BY OWNER 28880 Aranel (W of Orchard Lk S of 13) Sparkling 3 bed ranch on corner lot Distinctive ceramic tile kitchen beautiful hardwood floors large finished bsmt refreshing sunroom 3 way woodburning fireplace freshly painted inside Newer windows & utilities 1 5 baths 5 min walk to Kenbrook School \$252 900 Call today Appt only 248 553 5815

LET'S MAKE A DEAL on this private court lot & backing to the commons on this 2 098 sq ft 4 bed 2 1/2 bath colonial w/full basement newer furnace & central air windows w/two bays 25 year roof garage doors immediate occupancy family room w/natural fireplace & tons more CALL KEN GENTILE Quality GMAC (734) 542 2538 or CELL (734) 968 7213

REAL-ESTATE at it's best!
Observer & Eccentric

NEW ON MARKET!
Prestigious Hunt Club Sub Blue ribbon Hillside Elementary Immaculate 3 bed 2 5 bath colonial w/optional 4th bedroom Open floor plan w/cathedral ceilings Corner lot OPEN SUN 1 4 \$355 900 (248) 939 1399

SPECTACULAR WOODED LOT is first impression on this contemporary 3 259 sq ft Cape Cod offering first floor master bed w/master suite bridge balcony overlooking great room guest bed w/full bath Jack & Jill bath share 2nd & 3rd bed full walkout basement first floor laundry & den and tons more CALL KEN GENTILE Quality GMAC (734) 542 2538 or CELL (734) 968 7213

SPLENDID 3 Bed brick ranch sits on 5 acre wooded lot on cul de sac 1 5 baths finished bsmt 2 5 car garage all appliances Lots new! \$209 000 Appt only 248 891 8002

Classifieds Work!

Century 21 Chalet
Sherry Balhorn

LIVONIA
Great locat on tri level Three bedroom with newer furnace roof updated oak kitchen w/with ceramic tiles 11 1/2 size covered patio 2 car attached garage \$184,500

FARMINGTON HILLS
Need a spacous home with a large lot and an oversized garage? This is it! Over 1900 sq. ft. Almost 2/3 acres and 3+ car garage First flndry brand new kt All appl stay Neutral paint & carpet Cath ceilings Home Warr \$228,000

LIVONIA
Over 1300 sq ft Livonia ranch on 2/3 acre Character and charm Updated oak kitchen w/with ceramic tiles and plumbing Family room with fireplace \$157,900

BRIGHTON
3 BR ranch in Ridgewood Sub Kit features dbl convection oven gas cooktop oak cab Lovely hearth room w/fireplace ash HW floor mstr BR w/WIC & bath w/garden mstr WO bsmt cr drive \$370,000

LIVONIA
Great updated on this home with newer furnace C/A Beautiful cozy family room with fireplace Freshly painted Updated 1/2 bath Excellent eat in spacous kitchen All appliances stay \$174,900

REDFORD
Seller must sell 3 bedroom 2 bath home in a nice area. Newer roof driveway glass block windows updated bsmt bathroom HW floors & new windows in 2003. One year home warranty \$140,000

LIVONIA
Large two bedroom condo Newer furnace water heater carpeting Doorway from living room to balcony with a great view of the woods Carport Walk in closet and lots of storage area \$109,900

LIVONIA
Move in condition and unit condo boasts big BR's full bsmt HW floor under carpet covered ceilings & Livonia schools Newer vinyl wind freshly painted kit C/A neutral decor throught Private entrance \$94,900

REAL ESTATE CAREER INTERVIEWS WEDNESDAYS 6:30 P.M.

Ask About Exclusive Buyer Representation
Century Plaza
Corner Five Mile & Newburgh
37290 Five Mile Road
Livonia, MI 48154
(734) 432-7600

AMERA MORTGAGE CORPORATION

FREE Pre-Approvals "0 DOWN"
Call Today For More Information!
PAUL RICHER
AVP/Branch Manager
Pager: (610) 595-6700.
(734) 462-2771

**3900-3980
Commercial/Industrial**

3900	Business Opportunities	3940	Industrial & Warehouse For Sale
3910	Business/Professional Building	3950	Office Business For Lease
3920	Commercial/Retail For Lease	3955	Office Space For Sale
3930	Income Property For Sale	3960	Commercial & Industrial For Lease
3935	Industrial & Warehouse For Lease	3970	Investment Property
		3980	Land

1-800-579-SELL

**3000-3980
Real Estate
For Sale**

Homes 3000

FREE FORECLOSED HOMES
Beautiful 3 4 5 bedroom bank homes All areas includes addresses phone numbers Prices from \$10 000 No money down Free listings Please visit www.FreeBankHouses.com

Open Houses 3030

ATTRACTIVE 4 bed Colonial in Windridge Village By Owner \$289 900 248 477 2948

BELLEVILLE FOR SALE BY OWNER 4 bed 2 bath 209k A must see! Open Sun 3/21 & 3/28 11 5PM 734 699 9403 hno com 1D #17590

Open Houses 3030

Bloomfield Hills Open Sun 1 4
The Heathers Condo (Square Lake & Opdyke Rd) 3 bed 3 1/2 bath walk out lake view on golf course \$539 000 248 322 5587

Canton Open Sat Sun 11 6PM
Beautiful Pulte in Central Park 2636 sq ft 4 bed 3 bath 3 car 407 Spangfield \$399 900 734 398 6857

CANTON OPEN SUN 1-5 WOW! \$205K!
Fabulous 3 bed 2 5 bath colonial master w/private bath 2 car attached garage fireplace huge fenced yard w/deck, great cul de sac & more! 44837 Cranbrook Ct S/Palmer W/off Sheldon (River Park Sub) or call for appt (734) 394 5659 (734) 451 5400

ROCHESTER HILLS Open Sun 1 4
866 River Bend (1 blk N of Avon off Livernois) fabu four brick ranch treed lot A must see! 3 bed 2 full 2 half baths outstanding kitchen with family room area living room w/gas fireplace dining room large finished lower level many extras! Agents welcome \$397 500 (248) 608 6970

FARMINGTON OPEN SUN 1-4
32718 Grand River River Glen Condo C 11 Lovely 2 bed unit close to shopping transportation \$86 900
JUNE KOHLER CENTURY 21 ROW (734) 464-7111

Don't Lose This Number!
O&E Classifieds 1-800-579-SELL

PLYMOUTH
Open 1 4 46184 Rockledge 3 bed 2 1/2 bath Ranch updated top to bottom Maple kitchen wood floors jetted tub private backyard Must see \$312 900
Remerica Signature JULIE FITZPATRICK 734-678 8054

Plymouth Twp OPEN SUNDAY 1 4 PM
15039 Willowbrook S of Five Mile W of Haggerty Brick ranch Lake Pointe 3 bed 1 5 baths Updated kitchen & bath Family room w/gas fireplace Beautiful hardwood floors Basement w/shprap rec room 2 car attached garage (L39WIL) \$252 500 (734) 451 5400

Belleville & Van Buren 3045
ADORABLE 4 bedroom 1 bath 1450 sq ft Cape Cod Deck fireplace 75x300 lot \$182 900 734 699 4299

Birmingham 3050
BEAUTIFUL VICTORIAN
3 years new Walk to town 5 bedroom 6 bath 3 fireplaces all the amenities you'd desire! By owner \$1 950 000 248 593 4776

BEVERLY HILLS 3 bed ranch on 1 acre site C/A fireplace bsmt garage \$364 900 SharaNet (248) 642 1620

BIRMINGHAM 1968 Holland
Charming 3 bed 1 bath finished bsmt new carpet Master bed w/walk in closet Newer kitchen bath w/dows roof a/c \$234 900 Jon 248 225 9068

CLASSIFIEDS THAT WORK FOR YOU! 1-800-579-SELL

Fair Housing Your Right, Our Business

As members of the NATIONAL ASSOCIATION OF REALTORS®, the METROPOLITAN CONSOLIDATED ASSOCIATION OF REALTORS® is proud of our contributions in support of the Fair Housing Act and other Fair Housing Compliance programs

Our REALTORS® have led the housing industry in promoting fair housing and are committed to opening the door of your choice

FAIR HOUSING OPENS DOORS
REALTORS ARE THE KEY

AMERA MORTGAGE CORPORATION

FREE Pre-Approvals "0 DOWN"
Call Today For More Information!
PAUL RICHER
AVP/Branch Manager
Pager: (610) 595-6700.
(734) 462-2771



Farmington Hills 3145

HOT! HOT! HOT! HOMES IN THE HILLS \$294,900 COLONIAL

Outstanding updated 4 bed 2.5 bath colonial has newer roof w/in doors kitchen furnace C/A & more!

\$279,900 RANCH Well maintained 3 bed 2 bath 1807 sq ft ranch w/add 1150 sq ft in professionally finished bsmt living room w/fireplace formal dining room oak kitchen w/breakfast area & 1st floor laundry C/A All appliances stay Deck over looks wooded lot 2 car attached garage (BR280)

\$124,900 BUNGALOW Immediate Occupancy Neat 2 bed home on lg corner lot Living room dining room plus eat in kitchen & big utility room Hardwood floors C/A Security system Many updates (WH214)

Century 21 Today (248) 855-2000 www.century21today.com

Fenton 3150 FERDALE Spacious 4 bed room 1.5 bath 1950 sq ft brick & vinyl bungalow hardwood floors vinyl windows newer furnace/AC fireplace Full basement, deck & handi cap access \$262,000 248 545 6054

When seeking out the best deal check out the Observer & Eccentric Classifieds! 1 800 579-7355

RECIPE FOR A HAPPY HOME! Take this spacious home sitting on 2 pretty acres and then add you! Home features nice living room with new carpet convenient kitchen has tile countertops breakfast bar and pantry Large family room with vaulted ceiling and doorwall to deck and private backyard New carpet in bedrooms newer windows newer garage and asphalt drive central air and more! Oakland County Fenton Schools \$192,900

PLENTY OF ELBOW ROOM Spacious 3 bedroom 3 bath ranch situated on nearly 2 acres Nice open floor plan with large kitchen and dining area with doorwall to back yard Split bedroom design with private master suite Nice living room pretty stone fireplace in formal dining room 1st floor laundry and more! Oakland County Fenton Schools \$184,900

Open Sun March 28th 1-4pm JUST LISTED! Spottish light bright and cheerful 2 story home on large landscaped site with peaceful views of country side Great floor plan with 1900 sq ft convenient kitchen and dining area leading to nice deck Comfortable living room with gas log fireplace Basement 2 1/2 car garage and more! Fenton Schools \$229,900

Open Sun March 28th 1-4pm JUST LISTED! Spottish light bright and cheerful 2 story home on large landscaped site with peaceful views of country side Great floor plan with 1900 sq ft convenient kitchen and dining area leading to nice deck Comfortable living room with gas log fireplace Basement 2 1/2 car garage and more! Fenton Schools \$229,900

Open Sun March 28th 1-4pm JUST LISTED! Spottish light bright and cheerful 2 story home on large landscaped site with peaceful views of country side Great floor plan with 1900 sq ft convenient kitchen and dining area leading to nice deck Comfortable living room with gas log fireplace Basement 2 1/2 car garage and more! Fenton Schools \$229,900

Open Sun March 28th 1-4pm JUST LISTED! Spottish light bright and cheerful 2 story home on large landscaped site with peaceful views of country side Great floor plan with 1900 sq ft convenient kitchen and dining area leading to nice deck Comfortable living room with gas log fireplace Basement 2 1/2 car garage and more! Fenton Schools \$229,900

Open Sun March 28th 1-4pm JUST LISTED! Spottish light bright and cheerful 2 story home on large landscaped site with peaceful views of country side Great floor plan with 1900 sq ft convenient kitchen and dining area leading to nice deck Comfortable living room with gas log fireplace Basement 2 1/2 car garage and more! Fenton Schools \$229,900

Open Sun March 28th 1-4pm JUST LISTED! Spottish light bright and cheerful 2 story home on large landscaped site with peaceful views of country side Great floor plan with 1900 sq ft convenient kitchen and dining area leading to nice deck Comfortable living room with gas log fireplace Basement 2 1/2 car garage and more! Fenton Schools \$229,900

Garden City 3170

UPDATED RANCH On a fenced yard 3 bed rooms large living room remodeled kitchen basement nicely decorated \$131,900

GREAT CORNER LOT Beautifully decorated 2 super size bedrooms 1.5 baths picture window in large living room dining L Good size bright kitchen Partially finished basement garage \$119,900

Century 21Nada, Inc 248 477 9800

Hartland 3200 LEASE W/OPTION TO BUY No bank qualifications 3600 sq ft luxury home On golf course w/private lake private inges Call Phil 248 750 1860

Open Sun March 28th 1-4pm YEAR ROUND ENJOYMENT with this all sports lake front home on Tyrone Lake! Nicely maintained and landscaped 2 bedroom ranch offers den living room 1.5 baths fireplace and Florida room 30x24 garage 77 ft of lake frontage natural gas and paved roads! A perfect place to call home or your own getaway! Hartland Schools \$239,900 Take M 59 East of US 23 to North on Fenton Road to West on Read to North on Bullard following open signs to 8668 Bullard Road

THIS IS NO PLACE LIKE HOME! Canal front home on private peaceful Bullard Lake Home features 4 bedrooms 2.5 baths formal living and dining room family room with full wall brick fireplace and doorwall to deck Finished basement 2 car attached garage and lovely tread setting! Great fishing lake Hartland Schools \$294,000

JUST LISTED! Charming 3 bedroom Cape Cod on nearly 2 acres in desirable Hartland Schools! Home features island kitchen with white cabinets 1st floor master bedroom with private bath Beautiful French doors separate family room and living room Doorwall off family room leads to newer multi level deck and wonderful backyard with pond Formal dining room basement 2 car attached garage and more! \$244,500

ENGLAND REAL ESTATE 888 211 9560 810 632 7427

Highland 3210

JUST LISTED! Spacious 4 bedroom 2.5 bath Colonial on large lot in desirable Axford Acres! Private park and beach with boat access to all sports Duck Lake down the street! Beautiful newer kitchen with light oak cabinets and walk in pantry Spacious living room with vaulted ceiling family room with fireplace and doorwall to huge deck 2 car attached garage and beautiful yard! Huron Valley Schools \$232,900

ENGLAND REAL ESTATE 888 211 9560 810 632 7427

Lake Orion 3236 Keating sub w/lake access! Sharp 4 bed 2.5 bath has brand new kitchen ceramic carpet & restained hardwood All new fixtures & updated baths Immediate possession \$249,900 Call Terri Realty Executives Group (248) 701 7114

Linden 3240 THIS IS A KEEPER!!! Be the first owners of this new 3 bedroom 2 bath 2 story with peaceful setting on 2 acres Sharp convenient kitchen with maple cabinets comfortable great room with beautiful fireplace basement with daylight windows and plumbed for bath 2 car attached garage plenty of room for pole barn and in area of nice homes on acreage Linden Schools \$257,900

ENGLAND REAL ESTATE 888 211 9560 810 632 7427

Livonia 3250 18328 FLORAL AVE \$174,000 3 bed 1.5 bath garage new cedar deck carpet paint windows Call Angela 313 362 0120

3 BEDROOM BRICK RANCH 1300 sq ft full bsmt Great room 10 yrs old 2 1/2 car attached garage C/A Exc condition 27415 Dover W of Inkster N of Joy \$209,900 CALL BEN DENNY 734 453 8700 CROSSROADS

4 BEDROOM 2 5 BATH Colonial w/ finished bsmt & 2 car garage Updated kitchen furnace A/C roof Private lot w/ patio & screened porch \$265,000 (30LYN) CENTURY 21 ROW (734) 464-7111

Livonia 3250

LIVONIA \$374,900 RANCH On lovely 2 acre wooded parcel w/stream simply gorgeous 3 bed 3 bath ranch style home Fire place in living room family room & finished bsmt First floor laundry Updated roof trim furnace & C/A Home warranty (CU314)

\$249,900 COLONIAL Very nice 3 bed 2.5 bath colonial on super lot! Huge master bed Lovely finished bsmt 2 car garage Updates include roof furnace C/A hardwood floor in kitchen (R1147)

Century 21 Today (734) 462-9800 www.century21today.com

MOVE IN CONDITION 3 bedroom 1 bath brick ranch 1107 sq ft hardwood floors newer carpet 2 1/2 car garage 1 yr home warranty \$165,000 248 761 8895

OLD ROSEDALE GARDEN Colonial 3 bed 1.5 bath hardwood floors many updates finished bsmt 11404 Hubbard \$219,900 (734) 762 4238

RANCH 3 bed 1.5 bath Many updates finished bsmt large lot 7 & Inkster area \$139,900 586 755 7677

RANCH WITH FLAIR & LOCATION Great 6 Mile & Levan location this 3 bed brick ranch has been updated with perfection! Pella windows remodeled kitchen & baths hardwood floors kitchen is open to family room w/fireplace newer furnace & C/A brick paver driveway & patio bsmt 2 car attached garage \$229,900

MARLENE KLIMECKI Cell 248-933-7655 248 348 3000 ext 261 RE/MAX 100

Northville 3280 CITY OF NORTHVILLE 569 Morgan Circle 1900 sq ft Colonial completely redone must see! Walking distance to Downtown and the schools Open House 3/28 and 4/4 \$349,900 248 349 4569 248 982 4570

COLONIAL 4 bedrooms totally updated walk to town & schools wooded lot \$264,900 (248) 722 6772

JUST LISTED 4 BEDROOM 2.5 Bath Colonial Dining room family room w/ fireplace library main floor laundry full bsmt & 2 car garage Must see! \$374,900 (62NOR) CENTURY 21 ROW (734) 464-7111

N BEACON WOODS (8/Beck) 3 br 3.5 bath ranch 1990sq ft 3 car garage finished bsmt \$379,900 (248) 449 7668

N BEACON WOODS (8/Beck) 3 br 3.5 bath ranch 1990sq ft 3 car garage finished bsmt \$379,900 (248) 449 7668

Novi 3290 ★BARCLAY ESTATES cut de sac location 4 br 4.5 bath 3450sq ft hardwood floors finished bsmt \$599,000 248 345 5050

NOVI VISTA HILLS SUB 2566 sq ft 4 bed 2.5 bath 1st fl master great room dining den finished bsmt w/daylight windows bath & wetbar \$395,000 Open Sun 3/br by appt 248 926 5280

Redford 3350

RANCH 3 BEDROOM 2.5 Bath Newly refinished hardwood throughout newer windows and roof Neutral throughout \$159,900 CALL PATTY HAWLEY 734 459 6222

REMERICA HOMETOWN It's no gamble

when you advertise in The Observer & Eccentric Classifieds! 1-800-579-7355

REDFORD BEST BUY SUPER BRICK RANCH SUPER PRICE \$109,900 is a good price for this really nice Ranch many updates C/A Rec room garage MAYFAIR REALTY 734-522-8000

Salem/Salem Township 3380 CUSTOM 2160 SQ FT cape cod many upgrades large deck acreage 24x36 ft barn horse is allowed possible in law suite \$450,000 By owner (248) 486 5314

Southfield/Lathrup 3390 SOUTHFIELD \$175,900 RANCH Well maintained 3 bed 1.5 bath brick ranch w/ 2 car detached garage Living room w/fireplace Formal dining room Updated kitchen Lovely finished basement Spacious fenced yard w/ patio (RE277)

\$155,900 RANCH Cranbrook Village 3 bed ranch w/totally updated kitchen & refinished hardwood floors Huge living room w/dining L finished bsmt w/glass block windows & cedar closet Updates include roof & chimney leaf guard gutters C/A deck & more! (CA294)

Century 21 Today (248) 647-8888 www.century21today.com

SOUTHFIELD Spacious 4 bed 2 story brick bungalow lg living room w/dining area Step down TV room w/wood plank floor Designer kitchen w/top of the line appliances Full bath w/separate tile shower Bsmt w/fireplace Attached garage Wooded yard w/fire pit & several concrete patio areas \$179,900 (WE181)

Century 21 Today (313) 538 2000 www.century21today.com

South Lyon 3400 FOR SALE by owner 48 acres on major paved road Northfield Twp S Lyon Schools Includes house 10 stall horse barn several fenced paddocks training track pond outbuildings House 4 br poss 5th 3 full baths 4 fireplaces cathedral ceilings 1st floor laundry 1st master br w/ jacuzzi large country kitchen great room den mud room deck inground pool CA appliances By appt only (248) 380 3834 No Realtors

Waterford 3423 WELL BUILT CANALFRONT RANCH N Waterford close to Clarkston 5 mins to I 75 Must see (248) 673 1781

West Bloomfield 3440 Dock Beach 2300 sq ft 4 bedroom 2 1/2 baths Dead end location \$269,000 248 363 4361

THE RIGHT HOME! Wonderfully maintained 4 bed 3.5 bath polished granite master w/direct ceiling & walk in closet Finished lower level vinyl bath Award winning West Bloomfield schools \$285,000

QUIET NEIGHBORHOOD Large backyard Huge family room Master w/bath & her closets New furnace & C/A 5 year old roof All appliances stay Home Warranty \$829,000

BRING YOUR BOAT! Water club privileges include a club house & restaurant Bring your boat Large yard & deck for entertaining 4 bed spacious w/lots of storage Birmingham schools \$389,000

Westland 3445

1997 BUILT First floor master suite in this wonderful cape cod First floor laundry 2 car attached bsmt pool deck and sprinklers First class \$224,900

LOW MONEY DOWN Sharp new listing 3 bed brick ranch w/ finished bsmt New kitchen in 99 doorwall to large deck remodeled bath immediate occupancy! Just \$145,000

Call The Anderson's Century 21 Dynamic (734) 728 7800 Direct 6900 N Wayne Westland

BEAUTIFUL 4 bed 2.5 bath colonial built in 91 Freshly painted & carpeted Lots of extras Millwood Village Sub Livonia schools \$255,900 (734) 266 8070

BRAND NEW \$139,900 3 bed brick ranch bsmt Rcss Realty 734 326 8300

CUSTOM BRICK RANCH 1 acre 3 bed 2.5 bath living room w/fireplace dining room 2 car attached garage 36060 Oakwood Lane \$259,900 (734) 729 0975

Gorgeous Street in desirable Curtis Woods Sub Immaculate 3 bedroom ranch to city code Basement brand new kitchen & carpet family room fireplace central air all updated & painted Large fenced lot 2 car garage \$162,900 Call owners Judy or John 734 397 1394

LIVONIA SCHOOLS Ranch Natural Brick fireplace in Living Room Remodeled kitchen updated Bath w/ Jacuzzi tub 2 1/2 car garage \$132,900

LARGE 4 BEDROOM Farmhouse huge kitchen w/ Doorwall dining Room Florida Room 2 car garage On a large lot. Only \$124,900

CASTELLI (734) 525 7900 Serving the area for 29 yrs

NEW CONSTRUCTION Hamilton/Melton 3 bed full basement c/a 1200 sq ft attached garage 1st floor laundry \$185,000 734 341 6743

Macomb County 3530 SHELBY TWP Luxury home in exclusive sub 5068 sq ft fully finished w/lot 5 bed 4.5 bath Need to see quickly Call 586 242 7386 Visit gonehome.com ad # 070571 for details

Oakland County 3540 AVOID REAL ESTATE COMMISSIONS 1 877 GO FLAT RATE J Edwards Broker

Wayne County 3570 ROME SCHOOLS 4 bed ranch 1 acre Cranberry Lake access By owner \$189,900 586 531 5480

PLYMOUTH Custom built 4 bedroom 3 1/2 bath colonial with open floor plan Vaulted ceiling library/study Custom built patio \$649,900 (49P0)

LIVONIA Gorgeous 4 bedroom 2 bath brick ranch in great area Updates include kitchen plumbing and electrical Beautifully landscaped with sprinkler system \$198,900 (14CA)

Real Estate Services 3640

ACT NOW! Local company can buy or lease your house FAST! Any area any price range Call (734) 769 8176 24/7 recorded message

Condos 3720 Bloomfield THE HEATHERS Detached condo w/1st floor master ste Finished lower level w/sauna Private setting \$479,000

End unit ranch condo overlooking the 5th green Newer kitchen Special extra dining area \$399,900 The perfect time to move in and enjoy Bloomfield's premier golf community! Kathleen Robinson 248 646-2517, Ext 208 or E mail krobinsoc@realstateone.com Real Estate Man...

BLOOMFIELD (HEATHERS) ON GOLF COURSE 2 bed 2.5 bath Priced to sell N off Sq Lake take Scarborough Way right to Loch Creek to 2470 Wild Brook Run Open Sat & Sun 12 5 \$317,700 248 332 3305

BLOOMFIELD HILLS MUST SELL Adams Woods Condo 248 245 0158 BRIGHTON Cheaper than rent 1 bed condo \$69,900 Move in cond 248 624 0078

CANTON Brand new condo in great area 1380 sq ft w/2 bed 2 bath 1 car garage wide open layout with neutral color thru out all appliances stay \$155,900 (734) 837 5029

CANTON TOWNHOUSE 3 bed 1.5 bath over 1200 sqft total ly updated professionally landscaped New deck \$151,900 (313) 598 4203

FARMINGTON Charming & tranquil 2 bed 1.5 bath near Downtown Farmington \$112,400 (248) 950 6489

FARMINGTON HILLS 12 Mile/Orchard Lake Spacious 2 bed 2 bath condo Minutes from expressways & shopping \$110,000 By appt only (248) 539 3752

Linden Schools Open Sun March 28th 1-4pm SPRING SPECIAL! Sharp condo located in the City of Linden! Condo includes 2 bedrooms 2 baths 1st floor laundry basement 2 car attached garage and many quality features! Model priced at \$169,900 Only a few units left hurry before they are all gone! Take Owen Road West of US 23 to North on Linden Road follow open signs to Creekwood Condominiums ENGLAND REAL ESTATE 888 211 9560 810 632 7427

Local Events Online hometownlife.com COMMUNITY CALENDAR

CLASSIFIEDS WORK! 1-800-579-7355

Call to place your ad at 1-800-579-SELL(7355)

CROSSWORD PUZZLER

ACROSS 1 Banjo cousin 4 Boors 8 Gator Bowl st 11 Treadmill unit 13 Mrs s daughter 14 Allow 15 Blake of "Gunsmoke" work 17 Cheerful 19 Cheesy snack 21 Formal attire 22 Heavy metal band 24 Pleased sigh 26 Stangy OK 29 "la vital" 31 Caribbean liquor 33 "Gidget" actress 34 Mag exec 35 Phoenix cager 37 Undergrad degs 39 Pharmacy letters 40 Oklahoma town 42 Winter mo 44 Tomb Raider star 48 Colored 48 Sharp turn 50 Told a whopper 51 Rev the engine 53 Poker play 55 Did garden work 58 Grope about 61 APE datum 62 Padded glove 64 Holiday number 65 Cave maybe 66 Elevator maker 67 None at all

DOWN 1 Ms Thurman 2 Kipling novel 3 Large antelopes 4 Nebraska tribe 5 Cartoonist - Capp 6 Common ill 7 Fall mo 8 Worked a muscle 9 Actress - Thompson 10 LL D holder 12 Passes as a bill 16 Govt seat 18 Pay for 20 Dory s need 22 In front 23 Tea container 25 Wheel part 27 Eagle s nest 30 - Wiedersehen 32 Mil rank 36 Pierre s nose 38 Long faced 41 Greece s sea 43 Hopper 45 Portuguese port 47 Flop 49 Freebies 52 Veme s skipper 54 Greek N 55 Lump 56 Make do with 57 Telegraph signal 59 Luau welcome 60 House wing 63 Polesian plant

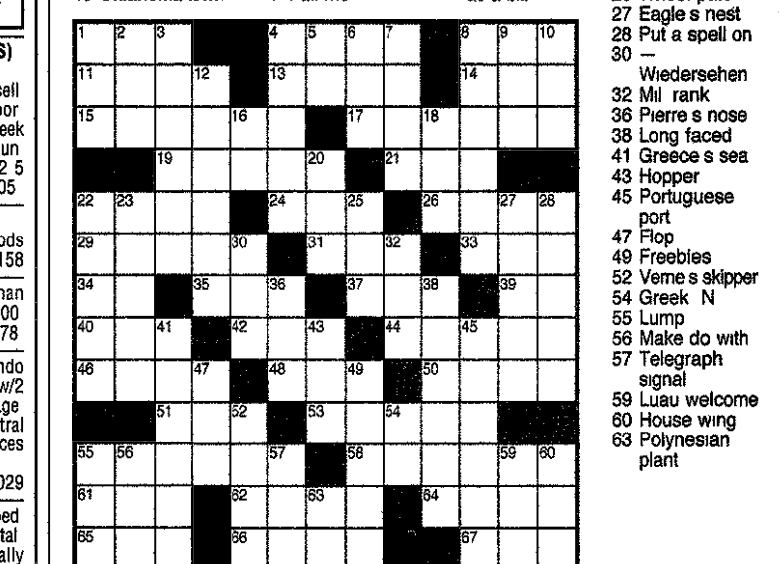

REALTOR Compliments of the MCAR Metropolitan Consolidated Association of Realtors

STUMPED? Call for Answers • Touch-tone or Rotary phones 95¢ per minute • 1-900-454-3535 ext code 708

Condos 3720

Livonia OPEN SAT 1-4 17879 University Park N of 6 W of Newburgh Sharp 2 bed 2 bath ranch condo Pool heated Florida room garage & newer kitchen Walking distance to shopping etc Close to X ways Reduced \$141,900 CALL ESTHER BAXTER 248 981 7885 MAYFAIR REALTY 734-522-8000 x243

CLASSIFIEDS WORK! 1-800-579-7355

Condos 3720

NORTHVILLE 1280 sq ft 2 bed 1.5 bath 2 story brick in popular Highland Lakes Updated kitchen newer appliances neutral carpet vinyl windows blinds fireplace Lakes pool clubhouse paths tennis court \$146,900 Open Sun March 28 1-4pm 42142 Farragut Ct off Silver Sprng near 7 & 8 Mi 517 548 5804

NOVI 3 Bed 1600 sq ft in Novi s beautiful Country Place Condos new furnace air & windows \$185,000 248 349 5738

Condos 3720

NOVI Open Sun 1-4pm 24604 Edgewood Dr 4 br 4 bath detached condo 1st floor master suite finished bsmt 2 car garage neutral decor immaculate Move in condition \$329,900 (248) 380 1524

NOVI Beautiful 2 yr old end unit 3 bedrooms 2 1/2 baths 1951 sq ft Many extras Ideal location \$289,000 248 624 1743

PLYMOUTH 55 & OVER 1 bed all appliances a/c Low maintenance fee New carpeting & appliances Priced to sell \$74,900 734 459 2629

Featured HOMES OF THE WEEK Presented By REMERICA INTEGRITY REALTORS. Dearborn Heights - Beautiful 3 bed Ranch with almost 1400 square feet Basement 2 1/2 car garage fireplace coved ceilings freshly painted Hardwood floors central air large corner lot large kitchen appliances are negotiable \$139,900 (11PEM). Livonia - Move right in to this gorgeous 3 bed Ranch This home features newer furnace central air windows roof siding and gutters Remodeled kitchen with oak cabinets and beautiful landscaping \$129,900 (11PEM). Livonia - Unbelievably gorgeous 3 bed 1 1/2 bath super Ranch 2 1/2 car garage deck off master bedroom with hot tub new Berber carpet new bath newer windows Ceramic foyer newer roof central air \$154,777 Call Jim Mariani @ 734 709 7777 (JM29PEM). Detroit - Super nice 2 bed brick home on a double lot 2 car garage basement 1 1/2 baths fireplace New windows furnace cement drive way Central air appliances stay hardwood floors fenced yard \$120,000 Call Hugh Granfeldt @ 734 347 7410 (HG80COL). Livonia - Prestigious Stonewater offers this fantastic Franklin floor plan with professionally finished walk out on Teal Lake with boat dock Three fireplaces sun room off nook crown moldings and tons more! \$999,900 (54PAF). Redford - Adorable and affordable 3 bed 1 1/2 bath home Basement 2 1/2 car garage hardwood floors fenced yard new landscaping Newer copper plumbing hot water heater & doors \$126,900 Call Dana McKay @ 734 751 5555 (DM17WAK). Redford - Absolutely beautiful 3 bed 1 1/2 bath brick Bungalow Updates include furnace central air windows sliding remodeled kitchen hardwood floors garage & full basement \$129,900 (22RIV). Redford - Large Colonial style on a nice sized corner lot 1 1/2 baths 1400+ square feet shed fenced yard basement new carpet to be installed in living room stairway and 9 x 12 bedroom \$105,000 (03MID). Livonia - Three bed 2 bath brick beauty! New Wallside windows finished hardwood floors newer roof furnace & central air Finished basement 2 1/2 car garage with electricity Hurry! \$159,777 Call Jim Mariani @ 734 709 7777 (21DEJ).

REMERICA INTEGRITY Locations in Livonia and Northville 734-525-4200 www.remericaintegrity.com EARN EXTRA \$\$\$ Booming Real Estate Office in Livonia and a new office opening in Northville is seeking outgoing Salespeople! Training Available. Call Robert or Kim at 734-525-4200



Condos 3720

ROCHESTER Luxury at a great price! Creekside Village cape cod 2100 sq ft 3 bed room 2 1/2 bath rec club like new original owner \$349 900 248 652 9363

ROYAL OAK CoventryPark 1757 Wictham Open Sun 1 5 2 bed 1 5 bath 1286 sq ft end unit w/carport \$150 900 (248) 435 6735

TROY TOWNHOUSE 3 Bed 2 full bath 2 car attach garage Wattles Creek \$212 500 248 273 0310

VAN BUREN CONDO 2 Bed 2 bath Large living room w/ fireplace Neutral decorated Oak kitchen w/ upgraded appliances \$123 900 CALL SHARON BLACK REMERICA HOMETOWN 734-459-6222

WESTLAND Ranch 2 bed 2 bath 1120 sq ft 1 car attached garage \$169 900 (248) 661 8634

WESTLAND 2 bedroom 1 bath attached garage \$100K selling for \$90K EZ Terms 734 762 9573

Westland DESIRABLE CASTLEWOOD CONDO Featuring an open floor plan vaulted ceilings oak cabinets in large kitchen large bed room w/spacious closet Backs to wooded commons breathtaking! Quick occupancy \$124 900

ROGER & SUE DAVIS Coldwell Banker Preferred (734)392 6022

Westland MOVE RIGHT IN 2 beds 1st floor laundry vaulted ceilings & skylights \$109 900

RANCH STYLE CONDO 2 bed 2 5 baths finished bsmt & 2 car garage \$179 000 Century 21 Towne Pride (734) 326-2600 www.century21townepride.com

When seeking out the best deal check out the Observer & Eccentric Classifieds! 1 800 579 7355

Condos 3720

Wixom 607 Shady Maple S of Maple W of Beck New construction condos open Sunday 1 4 Different floor plans & features Ranches & colonial 1st floor masters hardwood floors finished basement 2 car attached garage white kitchens & baths light wood kitchens & baths GE appliances fireplaces Starting at \$219 900 For more info call Lou Sabatini at (248) 855 2200 Cranbrook Associates Inc Realtors

Manufactured Homes 3740 * OPEN HOUSE * EXTRAVAGANZA Sat March 27th 12 4pm View over 20 new & proven homes Plymouth Hills Community on Ridge Rd (between 5 Mile & N Territorial) Stop at Little Valley office for list & map 734-454-4660

Call to place your ad at 1-800-579-SELL (7355) \$0 DOWN Save up to \$30 000 on a newer bank repo. Must pay sales tax. Discount Homes 866 251 1670

BRAND NEW 1580 sq ft 4 Bedrooms 2 Baths Deluxe GE Appliances only \$39 800 QUALITY HOMES at CEDAR BROOK ESTATES On M 59 W of Bogie Lake Rd (248) 887-1980

CANTON We have pre owned homes for sale or lease Call Sandy at Sun Homes for details at 734 397 0400

Manufactured Homes 3740

Canton College Park Estates Rental homes available 3 bedrooms 2 bath monthly rates less than \$450/month Call Dan 734 495 0012

Quality Homes Brand New 2003 Skyline over 1000 sq ft 2 BD 2 BA all de uxe appl inc washer/dryer separate laun dry room C/A skylights & more Reduced to \$34 900

Brand New 2003 Skyline over 1400 sq ft 3 BD 2 BA all deluxe appl incl washer/dryer fireplace sky lights & more Reduced to \$54 800 Only 2 Left!

Skyline Over 1200 sq ft 3BR 2BA all deluxe appl incs CA washer/dryer walk in closet corner lot Must see! \$49 900 Others Priced From \$14,000 to \$60,000

Novi Schools at HIGHLAND HILLS ESTATES on Seelye Rd N of Grand River bet Meadowbrook & Haggerty Rds Call Joanne or Sue (248) 474-0320 or (248) 474-0333

Picture Can Make A Difference! 1-800-579-SELL (7355) Observer & Eccentric

Manufactured Homes 3740

IN WIXOM Homes Under \$10,000! Handyman Specials 14x70 3BR 1BA \$7900 14x66 3BR 2BA \$9900 14x76 3BR 2BA \$9900 16x66 3BR 2BA \$9900

QUALITY HOMES at Commerce Meadows on Wixom Rd 4 miles N of I 96 (248) 684-6796

HOMES UNDER \$10,000 IN WIXOM Handyman Specials 14x70 3BR 2BA \$7900 14x52 2BR 1BA \$8900

QUALITY HOMES at Stratford Villa on Wixom Rd 3 5 miles N of I 96 (248) 685-9068

IN WHITE LAKE 14x76 3BR 2BA \$2900 16x72 3BR 2BA \$9900 16x76 3BR 2BA \$6900

QUALITY HOMES at Cedarbrook Estates on M 59 W of Bogie Lake Rd (248) 887-1980

Large Family 3 bedroom 2 bath shed C/A new washer & dryer LVH 248-474 6500

Little Valley Homes 5 Homes at or below cost Own a new home with lot rent included for less than \$575 a month No gimmicks Call (248) 476-4079 Based on 10% down 8.5% 180 months with approved credit

Manufactured Homes 3740

Repo 3 bedroom 2 bath shed fireplace, full sacrifice, L.V.H. 248-474-6500

Call to place your ad at 1-800-579-SELL (7355) Sacrifice! 3 bedroom 2 bath shed \$37 990 A must see! L V H , 248 474 6500

SAVE \$2000 PRICED BELOW INVOICE! New Homes \$19,900! 929 sq. ft. 3 Bedrooms 2 Baths GE Appliances Skylights & More

In Canton SHERWOOD VILLAGE Wayne Westland Schools on the southeast corner of M chugan Ave & Haggerty Rd (734) 397-7774

In Romulus HURON ESTATES On Inkster S of Sibley (734) 782-9300

Mobile Homes 3750 CARLTON 1990 2 bed 2 bath 14 x66 located in Novi \$6500/best 248 305 7223

WILL BUILD BUY LAND MOVE IT & FINISH IT FOR \$3000 DOWN Call 734 405 2414

CLASSIFIEDS THAT WORK FOR YOU! 1-800-579-SELL

Manufactured Homes 3740

SAVE \$2000 PRICED BELOW INVOICE! New Homes \$19,900! 929 sq. ft. 3 Bedrooms 2 Baths GE Appliances Skylights & More

In Canton SHERWOOD VILLAGE Wayne Westland Schools on the southeast corner of M chugan Ave & Haggerty Rd (734) 397-7774

In Romulus HURON ESTATES On Inkster S of Sibley (734) 782-9300

Mobile Homes 3750 CARLTON 1990 2 bed 2 bath 14 x66 located in Novi \$6500/best 248 305 7223

WILL BUILD BUY LAND MOVE IT & FINISH IT FOR \$3000 DOWN Call 734 405 2414

CLASSIFIEDS THAT WORK FOR YOU! 1-800-579-SELL

Lakefront Property 3770

ABANDONED LAKEFRONT \$59,900! Nicely wooded lakefront on a sand bottom lake w/ great swimming & fishing Guar anteed buildable w/ financing available

Loon Lake Realty 8am 6pm daily 888 805 5320 www.loonlake Realty.com

MACKINAW COUNTY 31 Acres on county roads nears lakes \$77 500 Will split (734) 697 4574

TRAVERSE CITY Up north retreat home w/124 on beautiful Lime Lake 3 bedroom 2 baths family room 2 car attached garage Southerly facing Peaceful setting among other quality homes \$675 000 Photo s & Tour www.marshmeyer.com Near Lake MI & golf

TRAVERSE CITY Unique home built 1999 private estate setting 2 3 acres w/295 waterfront on N Lake Leelanau 4 bedroom 5 full 2 half baths 5 000 sq ft 3 fireplace 3 car garage tennis court Near Lake MI golf \$2 975 000 Photo s & tour www.marshmeyer.com MARSHALL MEYER (800) 988 1333 COLDWELL BANKER SCHMIDT REALTORS 208 N Main St Leland MI 49654

Paradise On Little Traverse Bay in Petoskey Rare Find Waterfront Condo with absolutely nothing in your way on Little Traverse Bay Balcony provides ringside seat for spectacular sunsets! Walk ing distance to Petoskey's Gaslight District and Marina Directions for Arriving Sea farers? Step off Petoskey Marina and walk into The Sunset very very few people can make that statement!! Spectacular Bay Harbor Equi strian Club five minutes away perfect for Summer and Winter enjoyment!! Call LOU or CHARLIE 586 677 8898 Century 21 AAA North

Resort & Vacation Property 3800

Paradise On Little Traverse Bay in Petoskey Rare Find Waterfront Condo with absolutely nothing in your way on Little Traverse Bay Balcony provides ringside seat for spectacular sunsets! Walk ing distance to Petoskey's Gaslight District and Marina Directions for Arriving Sea farers? Step off Petoskey Marina and walk into The Sunset very very few people can make that statement!! Spectacular Bay Harbor Equi strian Club five minutes away perfect for Summer and Winter enjoyment!! Call LOU or CHARLIE 586 677 8898 Century 21 AAA North

Lots & Acreage/Vacant 3820

PLYMOUTH TWP 60 x 120 surveyed water sewer gas Next to 8890 Oakview \$120 000 (734) 216 9503

SALEM TWP 5 acres land contract (248)437 1174

Real Estate Wanted 3870 I BUY & LEASE HOUSES Any area condition or price 248 232 6336

Executive Home Wanted! Behind on Payments OK 734 769 8176 24/7 Recorded Message

It's All About Results Observer & Eccentric 1-800-579-SELL

NEED MONEY NOW? Then sell your home! Any condition any city I will stop your foreclosure No fees or costs \$ Fontana Properties \$ 248 866 8788

Cemetery Lots 3880

PARKVIEW MEMORIAL 4 lots Garden of Ascension less than 1/2 price (313) 291 3415

ROSELAND PARK CEMETERY 6 plots Section 361 \$595/ea (248) 496 8880

Business Opportunities 3900

Landscaping construction co 100K+ per season 22 yrs Plymouth area 734 455 8179

Romulus HAMBURGER PLACE PRICE REDUCED Corner lot Concrete block building good parking Eat in or out Close to GM plant \$225 000 or best offer CALL BEN DENNY 734 453 8700 CROSSROADS

Industrial & Warehouse For Sale 3935

BLOOMFIELD HILLS 1 75 & Square Lake Up to 1500 sq ft Utilities incl Asking \$1200/mo (248) 333 9846

Industrial & Warehouse For Sale 3935

Space for Lease 3 MONTHS FREE • RETAIL • Auburn Hills • Livonia • Pontiac • Westland • • LIGHT INDUSTRIAL • Belleville • Canton • Novi • Wixom • • OFFICE • Canton • Farmington Hills • Wixom • (248) 344-8970

Office Business For Sale 3950 1 000 to 15 000 sq ft in professional office in downtown Plymouth Available immediately Contact Tim Reilly (734) 737 2900 or Bob Kurtz (734) 737 2994

EXPRESSWAY EXPOSURE Month to month Avail 168 to 2700 sq ft 1 275 x way JA Bloch & Co/Gach Realty (248) 559 7430

25 Words + 13 Million Homes = Great Results

You can market your product to 13 million households throughout North America by placing your classified ad in more than 800 suburban newspapers like this one for only \$895

One phone call, one invoice one low payment is all it takes Call the Suburban Classified Advertising Network fax on demand service at 800 356 2061 or 312 644 6610 x4731 to speak with a sales coordinator



4000's Real Estate For Lease

- 4000 Apartments/Unfurnished
4010 Apartments/Furnished
4020 Condos/Townhouses
4030 Duplexes
4040 Flats
4050 Homes For Rent
4060 Lakefront/Waterfront Homes Rental
4080 Mobile Homes Rentals
4090 Southern Rentals
4100 Time Share Rentals
4110 Vacation Resorts/Rentals
4120 Living Quarters To Share
4140 Rooms For Rent
4200 Halls/Buildings
4210 Residence To Exchange
4230 Commercial/Industrial
4300 Garage/Mini Storage
4400 Wanted To Rent
4410 Wanted To Rent
4500 Resort Property
4580 Furniture Rental
4590 Rental Agency
4570 Property Management
4580 Lease/Option To Buy
4590 House Sitting Serv ce
4620 Home Health Care
4640 Misc To Rent

1-800-579-SELL

4000-4980 Real Estate For Lease

WESTLAND PLAZA*** Spacious 1 & 2 Bed Apts Quality Living Call for Current Specials Mon - Fri 9 5 - Sat 11 3 (734) 427 1997

BIRMINGHAM ETON SQUARE ASK ABOUT OUR SPECIALS! Featuring our 2 bedroom townhome with retro floor plan open staircase cozy woodburning fireplace full basement private patio must see! Ask for Amy at 248 644 1300

BIRMINGHAM ONE STOP SHOPPING NO RENT UNTIL MAY 1, 2004 425 E 14 Mile near Pierce Fully updated 2 bed/1 bath townhouse features all white kitchen with hardwood look flooring full basement deck & one car garage with opener Only \$875

Maple Road Townes Maple at Columbia (east of Eton) Walk to downtown from these charming & updated 2 bedroom townhouses (\$880) avail now 1 bedroom apt (\$750) and 1 bedroom townhouse (\$820) avail May 1724 Grant Lincoln & Woodward area 2 bed/1 5 bath townhome features spacious rooms with nice closets private yard carport \$1120 INCLUDES HEAT All have central AC 1 cat OK w/fee EHO Call The Bencke Group weekdays at (248) 642 8685

OR VISIT OUR OPEN HOUSE Thursday through Saturday from 12 00 Noon to 5 pm at 425 E FOURTEEN MILE RD

When seeking out the best deal check out the Observer & Eccentric Classifieds! 1 800 579 7355

CANTON 3 bedroom all appliances air deck \$1000/month 810-227 6733

Apartments/Unfurnished 4000

Canton BEST DEAL IN TOWN Exc Amenities & Service Super Move In Specials from \$471* 1 & 2 3 Bedroom Townhouse Apts CANTON GARDEN APTS (734) 455-7440 www.apartments.com/cantongardens *restrictions apply Unbeatable Value

CANTON BEDFORD SQUARE APTS NOW TAKING APPLICATIONS FOR Spacious 1 & 2 Bed Apts Small Quiet Safe Com plex Ford Road near I 275 STARTING AT \$585 (734) 981 1217

Dearborn EHO Dearborn Club *Save \$50/Month (866) 534-3358 www.cmpproperties.net *One bedroom apts

"It's All About Results" 1-800-579-SELL (7355)

Dearborn Heights SPRING INTO SAVINGS CAMBRIDGE APARTMENTS First visit \$50 off six months rent! (313)274-4765 www.yorkcommunit es.com

Farmington Hills Chatham Hills From \$545 REDUCED RATES! (866) 266 9238 www.cmpproperties.net

Farmington Hills Hugs 1 bedroom in beautiful apt com munity \$699/mo Andrea 734 663 1611 248 477 1510

FARMINGTON HILLS 1 bed 1 mo free! Spacious 1 & 2 bed Washer/dryer in unit \$565 \$700 (586) 254 9511

Local Jobs Online hometownlife.com JOBS AND CAREERS

Farmington Hills EHO Chatham Hills From \$545 REDUCED RATES! (866) 266 9238 www.cmpproperties.net

Apartments/Unfurnished 4000

Farmington Grand River Middlebelt Great Location Near Botsford Hospital Livonia Mall and Downtown Farm npton with Clarenceville School District CEDARIDGE APARTMENTS Limited Time Special 2 Bedroom Units FROM \$700 Vertical blinds carpeting security system storage within apt (Enter on Tulane 1 block W of Middlebelt S. side of Grand River) Model Open Daily 1 6 Except Wednesday 248 471 5020 586 775 8206

Farmington Hills Hugs 1 bedroom in beautiful apt com munity \$699/mo Andrea 734 663 1611 248 477 1510

FARMINGTON HILLS 1 bed 1 mo free! Spacious 1 & 2 bed Washer/dryer in unit \$565 \$700 (586) 254 9511

Local Jobs Online hometownlife.com JOBS AND CAREERS

Farmington Hills EHO Chatham Hills From \$545 REDUCED RATES! (866) 266 9238 www.cmpproperties.net

Farmington Hills Hugs 1 bedroom in beautiful apt com munity \$699/mo Andrea 734 663 1611 248 477 1510

FARMINGTON HILLS 1 bed 1 mo free! Spacious 1 & 2 bed Washer/dryer in unit \$565 \$700 (586) 254 9511

Local Jobs Online hometownlife.com JOBS AND CAREERS

Farmington Hills EHO Chatham Hills From \$545 REDUCED RATES! (866) 266 9238 www.cmpproperties.net

Apartments/Unfurnished 4000

Farmington Hills Earn a \$500 Rebate! * (Ask us how) • Pets Live Free • Covered Parking • 24 hr Fitness Center • In home Washer/Dryer • Sparkling Pool • Short term & furnished available

Reduced Rents! 1 bedroom from \$699* 2 bedroom from \$799* Diamond Forest Apartments Call toll free 877-262-7949 diamondforest.com *For a very limited time on select units Call for details

Farmington Hills Hugs 1 bedroom in beautiful apt com munity \$699/mo Andrea 734 663 1611 248 477 1510

FARMINGTON HILLS 1 bed 1 mo free! Spacious 1 & 2 bed Washer/dryer in unit \$565 \$700 (586) 254 9511

Local Jobs Online hometownlife.com JOBS AND CAREERS

Farmington Hills EHO Chatham Hills From \$545 REDUCED RATES! (866) 266 9238 www.cmpproperties.net

Farmington Hills Hugs 1 bedroom in beautiful apt com munity \$699/mo Andrea 734 663 1611 248 477 1510

FARMINGTON HILLS 1 bed 1 mo free! Spacious 1 & 2 bed Washer/dryer in unit \$565 \$700 (586) 254 9511

Local Jobs Online hometownlife.com JOBS AND CAREERS

Farmington Hills EHO Chatham Hills From \$545 REDUCED RATES! (866) 266 9238 www.cmpproperties.net

Apartments/Unfurnished 4000

Farmington Hills SUPER LOCATION Grand River/Orchard Lake STONERIDGE MANOR APARTMENTS Enter off Freedom Road W of Orchard Lake Road South of Grand River Deluxe 1 Bedroom sub-level From \$550/Mo 3rd month FREE Includes Carpeting vertical blinds deluxe appliances Non Fri 9 Sat/Sun by appointment Rental Office 248/478 1437 Home Office 586/775-8205

Farmington Hills HAPPINESS IS Moving into a cozy 1 bed apt with REDUCED RENT & SECURITY DEP Carpet & water included Starting at \$520 CEDARBROOKE APTS 248 478 0322

Farmington Hills WALNUT CREEK Large 1 Bedroom 0 Security Deposit w/credit approval STARTING AT \$485/Mo MUST SEE! Call (248) 951 2753

FARMINGTON MANOR APTS Deluxe studio & 1 bedroom, carport 1ST 3 MONTHS RENT 50% OFF! (With approved credit) 248 888 0868

FARMINGTON Sunview Apts on Farmington Rd S of 9 Mile Almond appliances vertical blinds beige carpet washer/dryer on each floor no pets Close to shopping 248 478 9380

FERDALE MI 3 Bed bath Newly remodeled shared parking and yard 2 m from I 696 \$750/mo 586 284 0360

FIVE Five Five ONE MONTH FREE To Qualified Applicants Studios 1 & 2 bedrooms available in town Birmingham 555 S Old Woodward Call Mari (248) 645 1191

Farmington Hills MAPLE RIDGE APTS CALL FOR SPECIALS! 23078 Middlebelt Spacious 1 & 2 Bedroom Central air car port available From \$560 248 473 5180

Local Jobs Online hometownlife.com JOBS AND CAREERS

Farmington Hills EHO Chatham Hills From \$545 REDUCED RATES! (866) 266 9238 www.cmpproperties.net

Apartments/Unfurnished 4000

Farmington Hills GARDEN CITY 1 bedroom near shopping monthly specials Heat included Blinds & carpet thru out 734 522 0460

GARDEN CITY'S FINEST! Quiet spacious 2 bedroom remodeled appliances air heat/water incl 248 474 3005

GARDEN CITY 1 bed newly decorated appliances heat & water \$535 +deposit; 734 261 6663 734 464 3847

hometownlife.com Livonia HUGE SAVINGS! • Minutes from I 95 • Dogs & Cats Welcome • Covered Parking • Fitness Center Pool • Extra Storage • Earn thousands toward your new home!

Up to 1 month FREE!* 1 Bedroom from \$599 2 bedroom from \$699 Woodridge Apartments Call Toll Free Today (888) 547-5828 woodridgeapartments.com *For a very limited time on select units Call leasing office for details

LIVONIA 14950 Fairfield 1 Bedroom \$615 Heat water wood floors Private patio/balcony 734 516-0539

LIVONIA CURTIS CREEK APTS Farmington Rd 6 1/2 Mile Private entrance washer/ dryer Pets Lease specials From \$715 248 473 0365

Madison Heights QUIET Almost soundproof 1 & 2 bedroom apts Across from Oakland Mall at I 75 and 14 Mile

CONCORD TOWERS 32600 Concord Dr (next to the Micro Center Store) 1 bedroom from \$665 2 bedroom from \$625 Carpets • Dishwasher Disposal • Central air 248-589-3355

NORTHVILLE NO RENT UNTIL MAY 1, 2004 Charming small community nestled in a wooded stream side setting We have a variety of unique 1 bedroom apartments and stunning lots from only \$675 All feature neutral decor blinds appliances covered parking EHO Tree Top Apartments Call (248) 347 1690 Novi Rd , north of 8 Mile

Apartments/Unfurnished 4000

Livonia's Finest Location MERRIMAN WOODS APTS Merriman Rd corner of 7 Mile Near Livonia Mall ASK ABOUT OUR LIMITED TIME SPECIAL One Bedroom Immediate Occupancy From \$600 includes Patio or balcony carpeting vertical blinds deluxe appliances pool 248 477 9377 586 775 8206

hometownlife.com Livonia HUGE SAVINGS! • Minutes from I 95 • Dogs & Cats Welcome • Covered Parking • Fitness Center Pool • Extra Storage • Earn thousands toward your new home!

Up to 1 month FREE!* 1 Bedroom from \$599 2 bedroom from \$699 Woodridge Apartments Call Toll Free Today (888) 547-5828 woodridgeapartments.com *For a very limited time on select units Call leasing office for details

LIVONIA 14950 Fairfield 1 Bedroom \$615 Heat water wood floors Private patio/balcony 734 516-0539

LIVONIA CURTIS CREEK APTS Farmington Rd 6 1/2 Mile Private entrance washer/ dryer Pets Lease specials From \$715 248 473 0365

Madison Heights QUIET Almost soundproof 1 & 2 bedroom apts Across from Oakland Mall at I 75 and 14 Mile

CONCORD TOWERS 32600 Concord Dr (next to the Micro Center Store) 1 bedroom from \$665 2 bedroom from \$

**Do-it-yourself is great for
sprucing up your home.
Not a good idea for selling it.**

There's a lot more to selling a home than just nailing down a sign in your front yard. It's a time-consuming, complicated process that's full of unknowns.

What you do know is that you want to sell your current home for as much as you can, and as fast as you can.

That's where a REALTOR* comes in. REALTORS* possess the right mix of knowledge, experience and training to help guide you through the process.

A REALTOR* will work with you to prepare, market, negotiate and close the sale of your home. It's what they do. So when it comes to selling your home, work with someone who'll work with you.



We're REALTORS
Real Estate Is Our Life.™

**THE
Observer & Eccentric**

NEWSPAPERS

*Recommends that you contact a Realtor**

Metropolitan Consolidated Association of Realtors

901 Tower Drive, Suite 190

Troy, MI 48098

248 879-5730



Apartments

All Ads Run Online FREE! A Value Of Up To \$87.00 www.hometownlife.com

Novi Westland FOUNTAIN PARK APARTMENTS Luxury You Can Afford MOVE IN FOR LESS THAN \$90.00

Plymouth SPRING INTO SAVINGS One Month Free Rent, plus 1st visit only, \$50 off 6 mo Rent!

Troy AWESOME! One Bedroom Homes! \$799. No! \$780. No! \$730 YES! THREE OAKS APARTMENTS

Westland Park Apts 2 MONTHS FREE RENT! 1st month \$300 2nd and 4th month FREE

BLOOMFIELD 2 Bed 1 1/2 bath 1100sq ft 100% up dated \$900 (includes heat & water)

ROYAL OAK Luxury Townhouse 2704 Rochester Rd 1 bed room loft 11/2 bath luxury townhouse

CLAWSON Near 14 Mile & Crooks Spacious 2 bedroom 1 1/2 baths features private entrance & yard carport

PLYMOUTH Downtown 3 bed New carpet enclosed porch Small pets considered \$1100 + security

ROSE LAKE Between Clare/Cadillac 2 bedroom \$1000/wk \$1200/holidays + \$200 sec dep

OAK PARK NORTH LINCOLNBRIAR APARTMENTS 2 bedroom 1 1/2 bath to 1160 sq ft

PLYMOUTH SQUARE APTS 50% OFF FIRST 3 MONTHS RENT 1 & 2 bedroom central air pool

Westland Huntington on the Hill \$99 Moves You In! (866) 395 0746

Westland SPRING INTO SAVINGS FREE RENT! Plus 1st Visit \$50 off six months Rent!

FARMINGTON 1 bed all appliances & heat incl \$645/mo 1 1/2 security No credit check

WESTLAND 3 bed shed 2223 Dalton Ct Wildwood & Palmer area \$865/mo total move in \$1000

ROYAL OAK 2908 Crooks 4 bed bsmt garage \$1200/mo Andary Realty (313) 886 5670

ROYAL OAK 3 bed near Beaumont bsmt hardwoods garage \$950/mo Small charge

WESTLAND Share clean non smoking spacious home \$350 1/3 utilities

Plymouth Hillcrest Club Standard \$550 Renovated \$575 FREE HEAT (866) 217-4106

PLYMOUTH Spacious Apts (13x18 living room) Heat & water incl all appliances

Westland SPRING INTO SAVINGS \$99 DEPOSIT One Month Free Rent plus 1st visit \$50 off

Westland SPRING INTO SAVINGS FREE RENT! Plus 1st Visit \$50 off six months Rent!

FARMINGTON HILLS LUXURY CONDO 14 Mile at Orchard Lake Road 2500 sq ft 2 bedroom 2 1/2 baths

WESTLAND 3 bed shed 2223 Dalton Ct Wildwood & Palmer area \$865/mo total move in \$1000

ROYAL OAK 3 bed near Beaumont bsmt hardwoods garage \$950/mo Small charge

ROYAL OAK 3 bed near Beaumont bsmt hardwoods garage \$950/mo Small charge

WESTLAND Share clean non smoking spacious home \$350 1/3 utilities

Plymouth NEED SPACE? WE HAVE IT! Largest 1 & 2 Bedroom floorplans in Plymouth

REDFORD 24757 5 Mile Quiet clean 1 bed \$525 + dep Appliances/heat/water Mon Sat 11 5pm 313 945 0524

Westland VENOY PINES APARTMENTS NEWLY RENOVATED KITCHENS & BATHS

Westland Spring Into Savings With 1 mo Free Rent + \$339 Move In

ROYAL OAK Spacious 2 bed in Normandy Oaks Newer kitchen balcony pool \$900/mo incl heat & water

ROYAL OAK 3 bed near Beaumont bsmt hardwoods garage \$950/mo Small charge

ROYAL OAK 3 bed near Beaumont bsmt hardwoods garage \$950/mo Small charge

ROYAL OAK 3 bed near Beaumont bsmt hardwoods garage \$950/mo Small charge

WESTLAND neat clean rooms Weekly plus deposit Call (313) 348 7404

PLYMOUTH PARK APTS 40325 Plymouth Rd TWO MONTH FREE RENT! 1 bedroom from \$600

ROYAL OAK Downtown 2 bedrooms newly carpeted Off street parking Quiet location \$550/mo 248 535 4043

Westland ADAMS SENIOR VILLAGE Condo style apts 1 & 2 bed avail A senior com munity for the young at heart

WESTERN HILLS APTS Call 734-729-6520 Open Mon Fri 8am 5pm

ROYAL OAK Spacious 2 bed in Normandy Oaks Newer kitchen balcony pool \$900/mo incl heat & water

ROYAL OAK 3 bed near Beaumont bsmt hardwoods garage \$950/mo Small charge

ROYAL OAK 3 bed near Beaumont bsmt hardwoods garage \$950/mo Small charge

ROYAL OAK 3 bed near Beaumont bsmt hardwoods garage \$950/mo Small charge

WESTLAND neat clean rooms Weekly plus deposit Call (313) 348 7404

PLYMOUTH SHELDON PARK APTS Spacious 1 & 2 bedroom central air Carport Walk to shopping

ROYAL OAK Downtown 2 bedrooms newly carpeted Off street parking Quiet location \$550/mo 248 535 4043

Westland ADAMS SENIOR VILLAGE Condo style apts 1 & 2 bed avail A senior com munity for the young at heart

WESTERN HILLS APTS Call 734-729-6520 Open Mon Fri 8am 5pm

ROYAL OAK Spacious 2 bed in Normandy Oaks Newer kitchen balcony pool \$900/mo incl heat & water

ROYAL OAK 3 bed near Beaumont bsmt hardwoods garage \$950/mo Small charge

ROYAL OAK 3 bed near Beaumont bsmt hardwoods garage \$950/mo Small charge

ROYAL OAK 3 bed near Beaumont bsmt hardwoods garage \$950/mo Small charge

WESTLAND neat clean rooms Weekly plus deposit Call (313) 348 7404

PLYMOUTH 1 & 2 bedroom Starting at \$555 includes heat Laundry facilities (248) 446 2021

ROYAL OAK Downtown 2 bedrooms newly carpeted Off street parking Quiet location \$550/mo 248 535 4043

Westland ADAMS SENIOR VILLAGE Condo style apts 1 & 2 bed avail A senior com munity for the young at heart

WESTERN HILLS APTS Call 734-729-6520 Open Mon Fri 8am 5pm

ROYAL OAK Spacious 2 bed in Normandy Oaks Newer kitchen balcony pool \$900/mo incl heat & water

ROYAL OAK 3 bed near Beaumont bsmt hardwoods garage \$950/mo Small charge

ROYAL OAK 3 bed near Beaumont bsmt hardwoods garage \$950/mo Small charge

ROYAL OAK 3 bed near Beaumont bsmt hardwoods garage \$950/mo Small charge

WESTLAND neat clean rooms Weekly plus deposit Call (313) 348 7404

Affordable One Bedroom Apartments For Seniors 62+ WESTGATE TOWER 34567 ELMWOOD WESTLAND from \$357 to \$482

It's no gamble when you advertise in The Observer & Eccentric Classifieds! 1-800-579-7355

BIRMINGHAM ONE STOP SHOPPING See our ad under Apartments for Rent Birmingham

ROYAL OAK 148 Amelia Approximately 1550 sq ft + full basement 2 huge bedrooms

CLAWSON Luxury Townhouse 447 N Rochester Rd # 4 2 bedroom 11/2 bath luxury townhouse

ROYAL OAK 3 bed near Beaumont bsmt hardwoods garage \$950/mo Small charge

ROYAL OAK 3 bed near Beaumont bsmt hardwoods garage \$950/mo Small charge

WESTLAND neat clean rooms Weekly plus deposit Call (313) 348 7404

DEARBORN HEIGHTS AREA Beautiful 1, 2 & 3 Bedroom 2 BEDROOM, 2 BATH VILLA 24-Hour Gatehouse Pets Welcome

CANTON SPACIOUS 1 & 2 BEDROOM Washer/Dryer hook up Self-cleaning oven Vertical Blinds

W. BLOOMFIELD 1 & 2 Bedroom Apts Air Conditioning Pets Welcome Dishwasher Microwave

REDFORD TWP. Office Space 2 3 Rooms Beautifully redecorated Private entry & bathroom

THE MICHIGAN GROUP

OPEN SUNDAY, MARCH 28



OPEN HOUSE 1-4 PM
BRIGHTON AREA \$389,000
10087 Spencer Rd
4 BRs 4 baths Old US 23 to Spencer house on North side Zoned Light Industrial can be used as home/office
MLS# 23104036/23103995
Host Carl Vagnetti Ext 253

 <p>OPEN HOUSE 1-5 PM BRIGHTON AREA \$469,900 5115 Pinewood Peaceful 1 acre wooded site 4 BRs 3 full baths glamour master suite Gourmet kitchen 2 screened in porches Finished LL near Oak Pointe Golf Course Brighton Rd West from Grand River to Mystic Pines Sub MLS# 24004508 Hostess Judy Urban, Ext 259</p>	 <p>OPEN HOUSE 1-4 PM BRIGHTON AREA \$249,900 5187 Braddock Ct 5 BRs 2 1/2 baths Love y family on parcel on vete cu de sac Vu y in day le basement 2 ponds Don't miss this one! Easy exp essway access Pleasant Valley Rd bet Grand Rve and Spencer East on Brandywine Rd Braddock 3rd street on right MLS #24002617 Hostess Cynthia Zimmerman 810 923-5230</p>	 <p>OPEN HOUSE 1-4 PM BRIGHTON AREA \$239,900 6241 Kevin Ct 4 BRs 2 1/2 baths Great family home just outside the city on almost an acre Brighton Lake Rd to Kevin Drive to Kevin Ct at cul de sac MLS# 23122653 Host Carl Vagnetti Ext 253</p>	 <p>OPEN HOUSE 1-4 PM BRIGHTON AREA \$229,900 11857 Knob Hill 3 BRs 2 1/2 baths Charming sub & lake access 2000 sq ft w/fin walkout LL Neutral decor throughout Pleasant Valley to L on Moraine R on Old Orchard L on Knob Hill Hostess Lori Ross Ext 232</p>	 <p>OPEN HOUSE 1-3 PM BRIGHTON AREA \$209,950 2787 Breckenridge Drive 3 BRs 2 1/2 baths Lake Edgewood Condo Spacious end unit Soaring ceilings loft private 2 level court yard with waterfall 3 decks (1 screened in) Gas fireplace in great room 2 car garage Assessment fees paid Grand River to Breckenridge Hostess Linda Strang Ext 252</p>	 <p>OPEN HOUSE 1-4 PM BRIGHTON AREA \$205,500 10848 Reynard 3 BRs 1 1/2 baths Fabulous family fun! Vacation at home in this beautiful Colonial w/access to Lake of the Pines beaches parks LR DR oak kit family rm fireplace lg BRs gorgeous woodwork of Pleasant Valley to Culver W to Greenfield N to Reynard MLS# 23070030 Hostess Kathy Krockert Ext 297</p>
 <p>OPEN HOUSE 12-3 PM HOWELL AREA \$508,000 2424 Allen 4 BRs 2 1/2 baths 1 mile W of Latson Rd This 15 acre horse farm is a must see! 30x40 barn 4 box stalls walkout lower level hot tub above ground pool 4 splits available MLS #24019886 Host John Underwood Ext 386</p>	 <p>OPEN HOUSE 1-4 PM HOWELL AREA \$424,900 226 N Truhn Rd, Fowlerville 4 1/2 baths Beautiful 6 BR country estate on 5 acres Mother in law suite Take Burkhardt Rd South from the Outlet Mall to Mason Turn West on Mason North on Truhn MLS# 24027692 Host Dennis Strasser Ext 337</p>	 <p>OPEN HOUSE 1-4 PM HOWELL AREA \$434,000 5704 Curdy 4 BRs 3 1/2 baths Log home on 6 acres w/100 year old hay barn Built in 1996 You must see this home to appreciate how nice this would be for your family MLS# 24012308 Host Tom O'Brien Ext 333</p>	 <p>OPEN HOUSE 2-5 PM HOWELL AREA \$349,900 1927 Sundance Ridge 4 BRs 3 baths Beautiful new ranch w/fin finished walkout Over 3200 sq ft w/o F replace 1st flr master suite dining room Great kitchen and steam ess appliances Landscaped w/mansard Sundance Meadows off Coon Lake Rd MLS# 23045395 Host Jeff Stamm Ext 225</p>	 <p>OPEN HOUSE 1 PM HOWELL AREA \$309,700 220 Summer Shade Drive 4 bedrooms 2 1/2 baths Country sub with water sewer sidewalks and st lights Home is just 1 year old 195 to D 19 N to first stop light & turn left 3 miles out Mason Rd to Maple Farms left Hostess Marcia Geise 810 844-2246</p>	 <p>OPEN HOUSE 1-3 PM HOWELL AREA \$239,990 4861 N Latson Road Almost new 4 BR 3 1/2 bath 3200 sq ft of liv ing space Professional fin walkout LL Back deck overlooks stream Sits on over an acre Howell Schools M 59 to N Latson Rd between Curdy & Clyde MLS# 24015520 Host David Miller Ext 247</p>
 <p>OPEN HOUSE 1-4 PM HOWELL AREA \$291,500 6433 Herbst Grand River to 5 on Dorr to Herbst/East Go East to Fst St North to address beautiful 3 BR 3 bath ranch w/walkout fin bsmt also pond/pole barn on 1.69 acres MLS# 23105506 Host Ron Laroche Ext 257 Direct Line 810-844-2257 Call #586-942 5273</p>	 <p>OPEN HOUSE 2-4 PM HOWELL AREA \$273,900 1610 Oak Square Ct 4 BRs 2 1/2 baths Come see the spectacular floor plan in this 2462 sq ft 4BR plus loft 1 1/2 story w/1st flr stone fireplace wood on over 13 acres in 40x40 pole barn tucked n back 1st flr mstr & laundry breakfast rm huge deck Immed occup Host Randy Meek Ext 220</p>	 <p>OPEN HOUSE 2-5 PM HOWELL AREA \$239,900 309 Victoria Park Very nice condo n historic Howell s vctor a Park! Lots of upgrades bglbrary wall n g eat room w/rep ace 2 bdrms 2 baths Just off M 59 & Mich gan Ave Private backyard area MLS# 24010845 Host Jeff Stamm Ext 225</p>	 <p>OPEN HOUSE 1-4 PM HOWELL AREA \$212,900 1877 Dutcher 3 bdrms 2 baths Norton Rd W to Pingee S W on Lange S on Dutche Attention ho se ove s th s is a coun try paradise 1400 sq ft ranch 40x24 pole barn w/ste a wate & elect 4 acres fenced & fenced pasture MLS #23104888 Hostess Elaine Hawkins Ext 250</p>	 <p>OPEN HOUSE 1-4 PM HOWELL AREA \$190,000 6205 Golf Club 3 BRs 2 baths Enjoy the country on over 1/2 acre 1569 sq ft open floor plan w/walkout ceiling Directions Grand River to Hughes (N) to Golf Club (E) MLS# 23125933 Hostess/Host Fran Thornell/Chris Ridalls Ext 346/341</p>	 <p>OPEN HOUSE 12-00-3-00 PM HOWELL AREA \$189,900 5965 E Grand River 3 BRs 1 1/2 baths Beautiful newer colonial home w/wideed great! waterfront access to a sports Lake Chemung This home includes a 20 ft pontoon boat & dock Home has open floor plan finished basement w/ess w/now Oak cabrnts ceramic in baths hardwood n hys & much more Grand River just W of Dorr Rd on N side MLS# 24028172 Hostess Janene Spencer, Ext 633</p>

BY APPOINTMENT ONLY

 <p>BY APPOINTMENT ONLY BRIGHTON AREA \$454,000 10435 Overhill Dr 4 BRs 2 1/2 bath Great location to 96 Over 3000 sq ft 1st flr master library granite island in kit walk out 3 car garage Formal dining extras Immed occupancy MLS# 23071004 Hostess Nancy Hubbell, Ext 217 810-844-2217</p>	 <p>BY APPOINTMENT ONLY BRIGHTON AREA \$413,500 11382 Cherrylawn 4 BRs 3 1/2 BA Unique 2 story w/3300 sq ft plus 1000 sq ft n fin w/o Sunken great rm w/waterfall ce ngs 3 full stone fire Secluded & wooded on over 13 acres in 40x40 pole barn tucked n back 1st flr mstr & laundry breakfast rm huge deck Immed occup Hostess Nancy Welka Ext 211</p>	 <p>BY APPOINTMENT ONLY FOWLERVILLE AREA \$190,000 7066 Stowe Rd, Fowlerville 3 BRs 2 1/2 baths Impeccable country ranch on 1 acre w/2 delightful 3 season room to enjoy the serene neighborhood Fowlerville Rd to W on Chase Lake Rd to N on Stowe Rd 1st dr ve on nght MLS# 24023084 Hostesses Diane/Fran Helmg Ext 218</p>	 <p>OPEN HOUSE 1-4 PM HOWELL AREA \$182,500 5912 Golf Club Rd 3 BRs 2 1/2 baths Ranch home Hartland Schools 2 acres Hacker to Golf Club Just past Argentine on South side MLS# 23110225 Host Carl Vagnetti Ext 253</p>	 <p>OPEN HOUSE 2-5 PM HOWELL AREA \$149,900 527 E Clinton Walk to lake park library & shops Opportunity to build equity 3 bedrooms 1 1/2 baths basement garage new roof carpet paint N of Grand River 1 block 5 bks E of Michigan Ave MLS# 24015310 Hostess Nancy Hubbell Ext 217</p>	 <p>OPEN HOUSE 2-4 PM HOWELL AREA \$186,000 1846 Hughes Rd 3 bedrooms 2 baths Grand River to Hughes Rd North to house 50 feet of frontage on Lake Chemung Hostess Natalie Armbruster Ext 396 Cell 810 923 5429</p>
 <p>BY APPOINTMENT ONLY BRIGHTON AREA \$189,900 9889 Weber Drive 2 BRs 2 baths Newly updated duplex just off Grand River & Old US23 Walk to VG s Lg fenced lot ve n one s de & rent the other O run your busness n one s de & lve in the other Grand River N on Old US 23 to Weber MLS# 2406255/24012470 Hostess Bonnie Lane Ext 207</p>	 <p>BY APPOINTMENT ONLY BRIGHTON AREA \$184,900 8591 LeGrand 3 BRs 1 bath All sports aka access sparkling newer 3 BR 1 bath ranch Great kitchen all appliances deck Pergo flooring fenced yard Shed Good occupancy MLS#231230724 Hostess Nancy Hubbell, Ext 217 810-844-2217</p>	 <p>BY APPOINTMENT ONLY HOWELL/BRIGHTON AREA \$579,900 4822 Treasure Lake 3 BRs 3 baths Executive estate This immaculate ranch sits on 12 park like acres just 5 minutes West of Brighton On a small wildlife lake Brighton Rd West of Chilton to Treasure Lake MLS# 23129098 Hostess Barb Hess, Ext 647</p>	 <p>OPEN HOUSE 1 30-4 00 PM BYRON AREA \$144,900 302 Warren 3 bedrooms 1 bath Village of Byron Darling ranch on 75 acres Newer deck many updates 2+ car garage MLS# 24013461 Hostess Nan Gregory Ext 245</p>	 <p>OPEN HOUSE 2-5 PM HOWELL AREA \$30,000 \$290,000 Sundance Meadows Sundance Meadows s open every Saturday and Sunday from 2-5 wth seaser brand new homes open this weekend! Family Park with Basketball & Tennis on Acre total D19 to Coon Lake Rd W 1/2 mile MLS# 24009679 Host Jeffrey Stamm Ext 225</p>	 <p>OPEN HOUSE 12-5 PM COMMERCIAL AREA \$309,900 9105 Campbell Creek 3 BRs 2 1/2 baths 1 1/2 new spacious traditional Colonial with overszbd rooms & garage TA bsmt w/daylight w n dow private cul-de-sac/golf course community 1 mi e off the M 59 cor dor to Coon Lake Rd on N side MLS# 24028172 Host Rob Schroder Ext 244</p>
 <p>BY APPOINTMENT ONLY HOWELL AREA \$389,900 4180 Rurik Drive 3 bedrooms 1 1/2 baths Waterfront living on beautiful all sports Coon Lake Large ranch new well & septic system Walkout basement in this 1660 sq ft ranch includes pontoon & motor Hostess Linda Barnwell Ext 316</p>	 <p>BY APPOINTMENT ONLY HOWELL AREA \$275,000 4389 Chilson 7 BRs 2 1/2 baths Attention investors or handyman! Large home w/loads of potential on 2 acres 3434 sq ft w/24x40 heated pole barn Great location! Bring offers! MLS# 24026302 Hostess Shirley J Bessert Ext 265</p>	 <p>BY APPOINTMENT ONLY HOWELL AREA \$254,900 127 Victoria Park 3 BRs 3 baths Immaculate open spacious floor plan backing to woods Great room has soaring ceiling w/ghyghts Total of 3240 sq ft of living area Finished w/o basement w/daylight w ndows Many upgrades & amenities MLS# 24025452 Hostess Fran Thornell Ext 346</p>	 <p>OPEN HOUSE 1-4 PM COMMERCE AREA \$239,999 2053 Paul s Way Just reduced! Immaculate 3 BR 2 bath quad New landscaping & porch A must see! Easy access to freeways BRng all offers Sellers motivated Maple to Welch North on Welch to Pauls Way MLS# 23113131 Host John Miskowski Ext 301</p>	 <p>OPEN HOUSE 1-4 PM FOWLERVILLE AREA \$229,000 5011 N Fowlerville Road 3 bedrooms 2 1/2 baths 1650 sq ft ranch w/walkout bsmt on 2+ acres Gorgeous inside open flr plan cathedral ceilings gas fireplace in liv rm Hardwood in kit foyer dining room MLS# 24023156 Hostess Denise Bible, Ext 277</p>	 <p>OPEN HOUSE 1-4 PM HOWELL AREA \$177,900 346 Springwell Lane 3 BRs 2 1/2 baths Just listed! Great home in family sub w/walking trail & playground Lots of space & beautifully landscaped & treed Ready for you to move in to w/all appliances Come see for yourself! MLS #24022399 Hostess Patty Purlington 810 844 2300</p>
 <p>BY APPOINTMENT ONLY HOWELL AREA \$235,000 2848 Bonny Brook 4 BRs Great cul de sac location on w/private back yard Open flr plan new contemporary paint hard wood in DR & kit 2 door walk to deck/ok paver patio Sun pond & lots of perennials Motivated sellers MLS# 24014004 Hostess Lisa Erhard Ext 684</p>	 <p>BY APPOINTMENT ONLY HOWELL AREA \$209,900 1008 Sunrise Park 3 BRs 1 bath Million dollar views right out your front windows! Completely remodeled a must see! great landscaped hilltop yard Close to everything w/privileges on Lake Chemung MLS# 24026302 Hostess Linda Barnwell Ext 316</p>	 <p>BY APPOINTMENT ONLY HOWELL AREA \$179,900 4514 Willow View Ct 2 BRs 2 1/2 baths Come see this another ng ranch style condo Vauted ce ngs and open floor plan Grand River to North on Latson Rd to East on Aste Blvd to North on Willow View MLS# 23129811 Hostesses Diane/Fran Helmg Ext 218</p>	 <p>OPEN HOUSE 2-5 PM HAMBURG AREA \$239,900 11446 Tall Shadows 3 1/2 BRs 2 1/2 baths Victorian flair Quality amenities Fireplace in great room oak kitchen all appliances deck treed site M-36 to McGregor S to Shenan E 1/2 mile MLS# 24043577 Hostess Nancy Hubbell Ext 217</p>	 <p>OPEN HOUSE 1-4 PM HARTLAND AREA \$349,900 8317 Glen Haven 3 bedrooms 2 1/2 baths Custom ranch over 2200 sq ft open plan Maple fire & cabinets ceramic in baths vaulted ceilings in great rm kit & dining rm 3 car garage walkout bsmt MLS# GLEN HAVEN Host Jon Sherman, Ext 279</p>	 <p>OPEN HOUSE 2-4 PM HARTLAND AREA \$349,000 7195 Mabley Hill 4 BRs, 3 1/2 baths Builders own home Energy eff 2330 sq ft plus 600 n fin walkout! Gorgeous views on 3 89 acres Harland Rd to Fenton Rd to W on Garmy to 1/4 m S on Mabley Hill MLS# 23105958 Hostess Cindy Steller Ext 644</p>
 <p>BY APPOINTMENT ONLY FOWLERVILLE AREA \$198,000 5670 N Fowlerville Road 4 BRs 1 1/2 baths Beautiful country setting 1 1/2 miles to town & expressway 1 35 acres wisharted private pond Open flr plan tiled kt deck off n ng room newer carpet n walkout bsmt Great view MLS# 23094652 Hostess Shirley J Bessert Ext 265</p>	 <p>BY APPOINTMENT ONLY FOWLERVILLE AREA \$179,900 11622 Glen Mary Drive 3 BRs 2 1/2 baths Just listed new house new sub! 3/4 ac a lot Bu der to pay \$1800 of buyers closing costs 1600 sq ft 1 e baths na wood floors n kt toys & 1/2 bath Fire ace in great rm na cele ava from \$35 900 Full bsmt Take Fowlerville to East on Lovejoy 1 1/2 m as MLS# 24025342 Hostess Christina Migliore Ext 298/297</p>	 <p>BY APPOINTMENT ONLY BELLEVILLE AREA \$235,000 24395 Elwell 3 BRs 2 1/2 baths Beautiful 1 1/2 acres su rounds this approx 2400 sq ft home Current 2 BR 1 BA has unfinished 30x40 addition w/FR mstr BR w/att BA & lg wex n closet Needs some TLC & new carpet 30x50 pole ba n MLS# 24016174 Hostess Shirley J Bessert Ext 265</p>	 <p>OPEN HOUSE 1-4 PM HIGHLAND AREA \$229,900 1700 Lone Tree 4 bedrooms 2 1/2 baths Price improved! 3 acres Huron Valley Schools Milford Rd to Lone Tree West or Hickory Ridge to Lone Tree East MLS# 24026931 Host Carl Vagnetti, Ext 253</p>	 <p>OPEN HOUSE 1-4 PM HIGHLAND AREA \$152,900 1690 Lombardy 1 BA Nice 3 BR ranch w/lots of updates Private lake access & boat launch to White Lk M 59 to LaSalle Blvd N (one block E of Duck Lake Rd) Hillsdale E to Lombardy to driveway Host Chris Ridalls, Ext 341</p>	 <p>OPEN HOUSE 1-4 PM PINCKNEY AREA \$299,900 8079 Pettysville Rd New construct on ready to occupancy 1876 sq ft 3 BRs 2 1/2 BA 16x12 bonus rm FF laundry gas FP n GR Open flr plan tile nance fee backs to private wooded lot Daylight w ndows n LL 9 ceiling prepard to add BA Lg covered porch convenient seat on close to 5 ghnon Sp nicle eyes & sood in asphalt drive plus 4 deck Hostess Nancy Welka (810) 844 2211</p>

michigangroup.com
6870 GRAND RIVER BRIGHTON
(810) 227-4600
South Lyon - 248-437-5000
Fenton - 810-750-6543

VOTED PEOPLE'S CHOICE

#1 REAL ESTATE IN LIVINGSTON COUNTY

SOLD SOLD SOLD

363 HOMETOUR

THE MICHIGAN GROUP

 <p>BY APPOINTMENT ONLY HAMBURG AREA \$24,900 2868 Masters Court 4-5 BRs 3 1/2 baths Seller transferred Immed occup Spacious custom 1 1/2 story 1st flr mstr room wood floors full fin w/o 3 car garage all stainless appliances MLS# 24011756 Hostess Nancy Hubbell Ext 217 810 844 2217</p>	 <p>BY APPOINTMENT ONLY HARTLAND AREA \$434,900 7110 McGuire 3 BR & 3 1/2 BA Envy Country Living on 10 ac Total of 3395 sq ft of living area Open 1 plan GR w/waterfall ce ngs has a nature FP (easily converted to gas) ba yden could be a 4th BR (Anderson windows & doors) Upper level has new carpet 50 x13 deck Many custom feat & amen hts Centrally located for easy access to x ways Must see MLS# 24031467 Hostess Fran Thornell Ext 346</p>	 <p>BY APPOINTMENT ONLY HIGHLAND AREA \$214,900 3517 W Grandview 2 BRs 1 bath Adorable lake home on all sports Woodruff Lake! Two lots w/116 ft lake frontage Beautiful yard w/mature shade trees & perenn at gardens New roof & well 2 car att garage 4 seasons porch MLS# 24016166 Hostess Shirley J Bessert Ext 265</p>	 <p>OPEN HOUSE 1-4 PM WHITMORE LAKE AREA \$279,900 7943 Turnberry 4 BRs 2 1/2 baths Beautiful home in upscale golf community Enjoy views of 10th Fa way Updates galore Huge master suite Landscaping spring Klers South Lyon School s US23 to 6 Mile East 2 miles to sub MLS# 24024782 Host Dennis Strasser Ext 337</p>
 <p>BY APPOINTMENT ONLY HOWELL AREA \$276,900 1417 Forest Ponds 3 BRs 2 1/2 baths Beautiful newer home in great neighborhood Sunroom 14x14 ceramic baths Jacuzzi tub Osmosis system 3 car garage professionally landscaped w/waterfall pond large treed lot MLS# 24011555 Hostess Rosie 734-645-8689</p>	 <p>OPEN HOUSE 1-4 PM PINCKNEY AREA \$153,900 165 Unadilla 3 BRs 2 1/2 baths Great starter home in the vil lage Across from a playground Many updates and room to expand Home Warranty included M 36 or D19 (Pinckney Rd) to Unadilla Don't miss this! MLS# 24026724 Hostess Amy Grescock Ext 258</p>	 <p>OPEN HOUSE 1-5 PM PLYMOUTH AREA \$239,999 9314 Sheldon Road 3 bdrms 2 baths Great L shaped ranch features open floor plan lg country kit replace hardwood floors & cedar closet A appliances included Great Met o location Sheldon just S of Ann Arbor Rd MLS #24008943 Host Dennis Swaney, Ext 398</p>	 <p>BY APPOINTMENT ONLY HOWELL AREA \$239,900 5912 Golf Club Rd 3 BRs 2 1/2 baths Ranch home Hartland Schools 2 acres Hacker to Golf Club Just past Argentine on South side MLS# 23110225 Host Carl Vagnetti Ext 253</p>



Jobs and Careers

All Ads Run Online

FREE!

A Value Of Up To \$87.00

www.hometownlife.com

5000's Jobs and Careers

5000 Help Wanted-General
6010 Help Wanted
5020 Office Clerical
5030 Help Wanted
5040 Help Wanted
5050 Help Wanted
5060 Help Wanted
5070 Help Wanted
5080 Help Wanted
5090 Help Wanted
5100 Help Wanted
5110 Help Wanted
5120 Help Wanted
5200 Help Wanted
5240 Help Wanted
5260 Help Wanted

3300 Help Wanted Entertainment
3320 Students
3340 Jobs Wanted-
Female/Male
3360 Childcare Services
Licensed
3370 Childcare/Babysitting
Services
3380 Childcare Needed
3400 Elderly Care & Assistance
3420 Nursing Care & Homes
3440 Summer Camps
3460 Education/Instruction
3480 Business & Professional
Services
3500 Attorneys/Legal Counseling
3520 Help Wanted-Tax Services
3540 Business Opportunities

1-800-579-SELL

5000-5080

Employment

Postings in this section

DRIVERS

CDL A 1 yr experience need
ed Afternoons & nights
Mileage & hourly runs Home
daily Call John or Paul 7am
5pm daily (734) 947 1405

APPOINTMENTS ONLY!

JOB FAIR

MARCH 27, 2004

HOLIDAY INN EXPRESS

3950 S Lotz Rd
Canton

Call ahead to schedule
an appointment
All Shifts Available!
On the Spot Interviews!
Temp to Hire Positions!
Immediate Job Openings
in Canton Plymouth and
Westland

Northwest Detroit Com
panies seeking motivated
hard working employees
for

- Packaging
- Assembly
- Machine Operators
- Forklift Operators
- Warehouse
- O/C Inspectors
- General Labor
- Plastic Machine
Operators a Plus

PAY RANGE \$7-\$14

Come Forge the Gaps
in your Pockets

Forge

Phone 248 474 4200
Fax 248 474 5799

ACCOUNTANT PART-TIME

Ferrdale Must be exp
General Ledger A/R A/P pay
roll proficient Excel Word
MAS90 a plus Please send
resume with compensation
req to bookkeeper@div
dat.com or fax to 248 399
5898 No phone calls or walk
ins please

ADMINISTRATIVE ASSISTANT

Well established Plymouth
based manufacturer seeks an
enthusiastic dependable team
player Good written and oral
communication skills a must
Requires professionalism in
answering phones and greet
ing customers while complet
ing other clerical and data
processing responsibilities
Microsoft Word and Excel a
plus Competitive wages and
excellent benefits Send
resume to: Clips & Straps
Industries 15050 Keel Street
Plymouth MI 48170 Fax
734 455 4270 E mail
HR@clipsclamps.com EOE

ANIMAL ATTENDANT ATTENTION PET LOVERS!

Work with pets! Walking
feeding bathing cleaning
\$8/hr Full time Non smoking
facility Will train Call for
details 248 372 7000

APARTMENT LEASING CONSULTANT

Full time position at River
Bend Apartments in Westland
Opportunity to work with pro
fessional apartment manage
ment & marketing team
Experience preferred Call
(313) 565-9650 or fax resume
to (313) 565 5807 or
E mail job@uzniz.com

Showers of Great Deals in your Classifieds!

APARTMENT LEASING CONSULTANT

Full time position at River
Bend Apartments in Westland
and Green Hills
Apartments in Farmington
Hills Opportunity to work
with professional apartment
management and marketing
team Experience preferred
Call for an appointment at
(313) 565 9650
or fax resume
(313) 565 5807

Advertising Space Planner

Our Livonia office is seeking someone to
work 18 20 hours per week Hours are
Tuesday Thursday and Friday 9 30 4 30 or
1 00 - 9 00pm The qualified candidate will
have 6 months to 1 year of experience in a
detail oriented clerical position and have
proficient computer skills A team player
who can maintain high levels of accuracy
and work within deadlines is a must!

Please send resume with salary requirements to

The Observer & Eccentric Newspapers
36251 Schoolcraft Rd.
Livonia, MI 48150
Fax: 734-953-2057
Email: employment@ee.hometownlife.com

Help Wanted-General 5000

AUTO PORTER

Large Westside Ford dealer
looking for the right individual
We offer exc pay plan & ben
efit package Blue Cross den
tal prescription vision
matching 401K life and dis
ability insurance paid vaca
tion and a five day work week
Great driving record a must
Applying in person only to Dan
Troost at Pat Milliken Ford ELC
LLC 9600 Telegraph Redford

AUTO SALES

High volume used car lot
downtown Plymouth ne
eds exp sales people or
possibly will train Earn up
to \$125K Ask for J R
(734) 455 5566

AUTO SERVICE ADVISOR

CRESTWOOD DODGE

(734) 421-5700

AUTO TECHNICIANS

CRESTWOOD DODGE

(734) 421-5700

AUTOMOTIVE TECH Must be
certified Full time 40 hours
Commission 734 765 1865

BATHTUB REGLAZER/
APPRENTICESHIP HELPER

Full time Good driving
record dependable Canton
(734) 459 9900

BLOCK MASON NEEDED

Experienced Livonia based co
looking to expand CDL a plus
but not necessary Fax resume
to Tony at 734 542 8147

CABINET MAKER &
LAMINATOR

Experienced
(313) 533-6134

CALL CENTER REPS

Farmington Hills Home
Improvement Co is hiring
appointment setters Full
time 12 30 8pm Mon Fri
Sat 10 30pm & Part Time
Mon Fri 10 2 \$8 \$10 per hr
plus bonus Professional atti
tude team player desire to
maximize income & utilize
sales skills Call Keith or Peter
after 11am 248 478 8600

CARPENTERS

Established west side contrac
tor looking for experienced
Roughers Top pay Health
insurance and retirement
plan 248-684 0174

It's no gamble

when you
advertise in
The Observer &
Eccentric
Classifieds!

1-800-579-7355

CARPENTERS

Large Carpentry & Millwork
Co looking for experienced
workers Farmington Hills
Ph (248) 427 1400
Fax (248) 427 1300

CARPET CLEANING TECHS

HCRC Certified preferred
Good driving record a must
Call 248 632 2406

CERTIFIED MECHANIC

Canton Plymouth Ann Arbor
areas Fax resume
734 397 8931

ASSISTANT DIRECTOR

LEAD TEACHERS

ASSISTANT TEACHERS

Childtime Learning Centers one
of the nation's leading
childcare companies seeks
energetic Assistant Director for
our Westland center AA/BA
in ECE/CDA & exp in ICD
childcare center reqd Call
734 729 3434

Our Canton center seeks
motivated Lead/Assistant
Teachers for our Canton
center ECE/CDA & 6 mo exp
in ICD childcare center
preferred Call 734 981 3222
Competitive salary & benefits
EOE M/F/D/V

CLEANING OFFICES Nights
in Canton & Plymouth Mon
Fri 7pm 1am 30 hrs/wk
Overtime pay for weekends
Paid vacations \$8 50/hr to
start 313 292 7842

CLEANING PERSON needed
full time days for cleaning
company Must have own
transportation 734 634 5196

CNC LATHE OPERATOR

This is NOT a production job
You must be able to do your
own programs and set ups for
Mold and Die contour work
Fanuc controls Night position
Send resume and wage
requirements to

31800 W Eight Mile Rd
Farmington Hills MI 48336
Or email
Barry@forgeprecision.com

CLASSIFIEDS

THAT WORK FOR YOU!

1-800-579-SELL

Help Wanted-General 5000

Communications

POLICE SERVICE AIDE (PSA)

CHARTER TOWNSHIP OF PLYMOUTH is accepting applica
tions for the position of
Police Service Aide (PSA) in
the Plymouth Community
Communication Center
(PCCC) Applicants must have
a high school diploma or
equivalent and be at the mini
mum of eighteen (18) years
of age with key boarding expe
rience All candidates will be
required to take a test Names
will be placed on a hiring list
This position is represented by
the POAM union

Essential functions for this
position include but are not
limited to the following
answering telephones request
ing information or services
(including emergency 9 1 1
calls for service) inputting
information to and operating
the Computer Aided Dispatch
(CAD) system filing requests
for information from LEIN and
other computer data bases
received from department per
sonnel dispatching police fire
and rescue to respective
runs assisting citizens with
requests for information or
complaints monitoring local
and state radio frequencies
operating emergency notifica
tion systems for community
warning announcements and
other various duties associat
ed with prisoners and the
lockup facility

Applications and position
specifications are available
Monday through Friday
between 8 00 a m and 4 30
p m in the Township Clerk's
Office 42350 Ann Arbor
Road (at the corner of Lilley
Rd) Applications must be
picked up and will be accept
ed until Wednesday April 7
2004 at 4 00 p m

The Township is an equal
opportunity employer

CONSTRUCTION LABORER/
UNDERGROUND PIPING

40+ hours a week
Must have own car Valentin
(313) 641 6196

COORDINATOR

For Southfield wholesaler
Fashion jewelry hats & wigs
Training provided Start
immediately (248) 262 6811

DELIVERY APPLIANCES

Will train for installations &
repair Apply at Bill & Rod's
Appliance 15210 Middlebelt
Livonia

Dietary Aide Part Time

Flexible hours exp a plus
15131 Newburgh, Livonia
734 484 9484 x 24
Behind St Ediths Church

DJ Female or Male

Nights only Call Frankies
btwn 3 00pm 734 421 3424

DRAWING TECHNICIAN

Exp Fax resume to
248 344 9935

DRIVER CDL Class A must be
25 yrs old w clean Driving
record to drive auto transport
for deliveries to Detroit Area
auto auctions Home Eves
Milford Co
Fax resume to 248 684 8713

DRIVER

Needed to transport medical
patients Call Administrator at
734 421 2020

DRIVER

Plymouth retail mattress store
seeks self motivated person
for delivery driver position 5
6 days a week 40+ hours
possible \$10/hr to start
Chauffeurs license a must
Call Tony (517) 404 3449

DRIVER - CDL TRACTOR TRAILER

To deliver building supplies
and steel in the tri county
area Salary and benefits
competitive Send resume or
apply at Smede Son Steel
12584 Inlander Rd
Redford MI 48239

DRIVER PART TIME

Delivery driver \$8 50/hour 34
hours a week Mon Fri Apply
(8 5) Sherwin Williams
Automotive Finishes 15324
Telegraph Rd (just N of 5
Mile in Redford)

DRIVER CDLA

\$15 75 Semi requires 2 years
semi experience good driving
record Call
Phoenix Personnel
734 284 2121

DRIVERS

Trucking co looking for
Semi Truck Drivers Exper
ienced only Call Mon Fri
9am 4 30pm 734-455-4036

Help Wanted-General 5000

DRIVERS - CLASS B \$40,000+

Looking for local delivery?
Like physical work? We've
got it! Roof top delivery of
stingles you won't need
to go to the gym after work
500 600 daily lifts @ 80#
Must have good driving
record Year round plenty
of OT and great benefits
Join a winner apply today

Wimsatt

36340 Van Born Rd
Wayne

Drivers Needed Panera, LLC

Panera LLC has immediate
need for customer
service oriented CDL
Drivers with air brakes
endorsement for our
Livonia MI facility Well
maintained reefer fleet
lift gated trucks for
rolling bakery cabinet
delivers Starting rate at
\$12/hour and
includes bonus/benefit
package Good driving
record a must Please
apply within 32713
Schoolcraft Rd Ste
106 Livonia MI 48150

Escrow Processor Experienced

For title company Good
working environment
Organizational skills re
quired Benefits included
Fax resume to
248 478 9815

ESTIMATOR Experienced
with integrity loyalty and
longevity for well established
auto body repair facility
Choice location in Redford
Fax resume to 313 592 4801
or gjuccia@comcast.net

IMAGING TECHNICIAN

Detail oriented person
needed to capture high
speed video and still
images at an automotive
test facility in Dearborn
Experience with digital pho
tography and proficiency
with PC computers is
required Applicant needs
to be a self directed prob
lem solver that is comfort
able working in an industri
al environment This is a
full time position with ben
efits that requires the avail
ability to work the day or
afternoon shift EOE Send
cover letter and resume to
Attn Imaging Technician
25689 Industrial Park Dr
Farmington Hills MI 48335

INDUSTRIAL PAINTER

Experience needed Metal
Guard Inc Please Call
(248) 477 2700

INSURANCE INVESTIGATOR

Activity checks field invest
igations surveillance Must
have own video camera Fax
resume to 248 557-4928
or mail to P O Box 760096
Lathrup Village MI 48076

JANITORIAL

Part time weekends for
Plymouth Church Call
Mon Fri 9 15 734-453 5280

JANITORIAL

Farmington/Livonia
Exp in floors Background
check & drug test required
\$8 50 \$9/hr (734) 434 8218

JANITORIAL EVENINGS

Approx 15 hrs per week \$10
per hour to start Call Sam
4pm ONLY 734 425 2610

JANITORIAL OPERATOR SUPERVISOR

West side experience with
transportation Call
(313) 831 3070 ext 247

JOB FAIR Monday March 29th 11-2 00, 4-7 00

Great full & part time
positions

Please apply in person
Barton Hills Country Club
730 Country Club Road
Ann Arbor 48105

GARDEN CENTER PART TIME RETAIL POSITIONS

Smiles only Glen
248 543 4400

GENERAL LABOR

For steel & building supply
yard Ability to weld a plus but
not necessary Comp etitive
starting salary & benefits
Apply at Smede Son Steel
12584 Inlander Rd
Redford MI 48239

GREENHOUSE & GARDEN CENTER

Inquire At 8000 Newburgh
Westland

GROUNDS PERSON

Dependable
person needed for outside
maintenance/ landscaping
for apartment communities
in Westland and Plymouth
area Flexible hours
seasonal full or part time
Call (734) 455 3880

HAIR STYLIST

FULL OR part time With clien
tele for busy Livonia salon
Call Paul 734 422 6730

HAIR STYLIST & NAIL TECH

w/some clientele 9/Middlebelt
Farmington Hills Salon Call
Sun Mon 248-344 1692

LANDSCAPE CONST SPRV

Self starter with excellent
organizational/management
skills Knowledge reading
plans ordering plants man
aging people and crews Fax
resume to 734-482 0400 or
call 734-482 1100

LANDSCAPER & IRRIGATION TECHNICIAN EXP

Needed full time Must be
dependable w/wald drivers lc
248 344 2217 248 486 5528

LATHE OPERATOR

Must have min 5 yrs exp on
large prototype parts Full
time benefits Apply by mail
or in person to 35100
Capitol Livonia MI 48150
734 427 8550

Help Wanted-General 5000

HOST/HOYESS NEEDED

for luxury builder's kiosk at
Great Lakes Crossing in
Auburn Hills No experience
necessary Days evenings
and weekends available
Object direct people to our
development in Clarkston
Requirement a smile and
pleasant personality
(248) 332 1600

HOUSEKEEPING & LAUNDRY MANAGER

Marywood Nursing Care
Center a 120-bed skilled
long term care facility located
in Livonia is currently seeking
a Director of Environmental
Services The qualified candi
date will have janitorial/house
keeping and institutional laun
dry experience A Bachelors
Degree is preferred but not
required Good organizational
and leadership skills an
absolute must Competitive
salary and benefits Apply at
Marywood Nursing Care Ctr
36975 Five Mile Road
Livonia MI 48154
(734) 464 0600

HVAC Techs & Master Plumber

Experienced
Commercial & Industrial
Service/Maintenance/In
stallation
Full time BC/BS Dental
401K Vacation Holidays
Education & a truck
+ \$1 000 new hire hat lun
dary Fax resume to 313 536 4403
\$18 \$32 per hour

LEASING CONSULTANT

needed for Farmington Hills
Apartment Community Full
time salary & benefits Must
have outgoing personality
Fax resume to 248-474 7043
or e mail to
fairmontparkapts@beztak.com
Fairmont Park Apartments
Located on the northeast cor
ner of 9 Mile & Drake
248 474 2510

LEASING (PART TIME)

Seeking dynamic addition to
our leasing staff Prior cus
tomer service or sales exp
helpful Weekends required
Call 734 455 7100
Mon Fri 9 30pm or
Fax resume to 734-455 7107

LEASING CONSULTANT

part time for Dearborn
Heighis area apartment com
munity Experience required
Great opportunity for right
person Please call
313 562 3988

LEASING CONSULTANT

with exp for part time posi
tion excellent working envi
ronment Start immediately
Fax resume to 734 261 1318

LEGAL SECRETARY

2 Farmington Hills attorneys
seeking experienced legal
secretary Ref req Fax
resume to 248 851 2481

LIFEGUARDS SWIM INSTRUCTORS SUPERVISORS CASHIERS

W. Bloomfield Parks &
Recreation seeking individuals
for summer help Competitive
pay flexible schedules
Contact Pool Manager Jon
Post (248) 378 2512

LOAN OFFICER

Allied Home Mortgage Capital
Corp is seeking ambitious
Loan Officers Experienced
only Generous commission
\$70 lenders Contact
Bert at 734 266 9190 or fax
734 266 9195 EOE

LOAN OFFICERS

Livonia office Looking for
4 more loan officers No
experience necessary 40
hrs/week Present
employees making \$40K
\$100K

LOAN SPECIALIST

Exp ONLY Salary + commis
sion MANAGER
johnmarras@mpower.com net
or Fax to John 734 402 2522

LUMBER LIFT TRUCK DRIVERS & YARDMEN

Gateway 60 Hattner Ste 300
River Rouge 888 799 4334

MACHINE TOOL ELECTRICIANS & PIPE FITTERS

Experienced or trainees
313 584 4196

MACHINISTS

2 5 yrs exp required
• CNC Grinder Hand/
Programmer
• CNC Mill Operator/
Programmer
• CNC Lathe Operator/
Programmer
• CNC EDM Operator/
Programmer
Job offers are for 2nd shift
only Must have own tools
We offer a competitive com
pensation and benefit pro
gram For information call
(734) 729 3100 ext 246

MAINTENANCE SUPERVISOR

On site position
Experienced maintenance
supervisor for mid size
apt community Know
ledge in all aspects of
maintenance including
HVAC Competitive salary
and benefits
Call (734) 729 5090
Fax (734) 729 8258

MAINTENANCE TECH

Part time for Southfield based
computer co Mon Fri 8am
12pm shift General repairs
electrical plumbing & grounds
clean up HVAC exp preferred
Send resume to Maintenance
Tech Glenn Computer Corp
24370 Northwestern Hwy Ste
300 Southfield MI 48075 or
email to employment@
glenncomputer.com

MANAGER

Part time for Southfield based
computer co Mon Fri 8am
12pm shift General repairs
electrical plumbing & grounds
clean up HVAC exp preferred
Send resume to Maintenance
Tech Glenn Computer Corp
24370 Northwestern Hwy Ste
300 Southfield MI 48075 or
email to employment@
glenncomputer.com

MANAGER

Part time for Southfield based
computer co Mon Fri 8am
12pm shift General repairs
electrical plumbing & grounds
clean up HVAC exp preferred
Send resume to Maintenance
Tech Glenn Computer Corp
24370 Northwestern Hwy Ste
300 Southfield MI 48075 or
email to employment@
glenncomputer.com

MANAGER

Part time for Southfield based
computer co Mon Fri 8am
12pm shift General repairs
electrical plumbing & grounds
clean up HVAC exp preferred
Send resume to Maintenance
Tech Glenn Computer Corp
24370 Northwestern Hwy Ste
300 Southfield MI 48075 or
email to employment@
glenncomputer.com

MANAGER

Part time for Southfield based
computer co Mon Fri 8am
12pm shift General repairs
electrical plumbing & grounds
clean up HVAC exp preferred
Send resume to Maintenance
Tech Glenn Computer Corp
24370 Northwestern Hwy Ste
300 Southfield MI 48075 or
email to employment@
glenncomputer.com

MANAGER

Part time for Southfield based
computer co Mon Fri 8am
12pm shift General repairs
electrical plumbing & grounds
clean up HVAC exp preferred
Send resume to Maintenance
Tech Glenn Computer Corp
24370 Northwestern Hwy Ste
300 Southfield MI 48075 or
email to employment@
glenncomputer.com

MANAGER

Part time for Southfield based
computer co Mon Fri 8am
12pm shift General repairs
electrical plumbing & grounds
clean up HVAC exp preferred
Send resume to Maintenance
Tech Glenn Computer Corp
24370 Northwestern Hwy Ste
300 Southfield MI 48075 or
email to employment@
glenncomputer.com

MANAGER

Part time for Southfield based
computer co Mon Fri 8am
12pm shift General repairs
electrical plumbing & grounds
clean up HVAC exp preferred
Send resume to Maintenance
Tech Glenn Computer Corp
24370 Northwestern Hwy Ste
300 Southfield MI 48075 or
email to employment@
glenncomputer.com

MANAGER

Part time for Southfield based
computer co Mon Fri 8am
12pm shift General repairs
electrical plumbing & grounds
clean up HVAC exp preferred
Send resume to Maintenance
Tech Glenn Computer Corp
24370 Northwestern Hwy Ste
300 Southfield MI 48075 or
email to employment@
glenncomputer.com

MANAGER

Part time for Southfield based
computer co Mon Fri 8am
12pm shift General repairs
electrical plumbing & grounds
clean up HVAC exp preferred
Send resume to Maintenance
Tech Glenn Computer Corp
24370 Northwestern Hwy Ste
300 Southfield MI 48075 or
email to employment@
glenncomputer.com

MANAGER

Part time for Southfield based
computer co Mon Fri 8am
12pm shift General repairs
electrical plumbing & grounds
clean up HVAC exp preferred
Send resume to Maintenance
Tech Glenn Computer Corp
24370 Northwestern Hwy Ste
300 Southfield MI 48075 or
email to employment@
glenncomputer.com

MANAGER

Part time for Southfield based
computer co Mon Fri 8am
12pm shift General repairs
electrical plumbing & grounds
clean up HVAC exp preferred
Send resume to Maintenance
Tech Glenn Computer Corp
24370 Northwestern Hwy Ste
300 Southfield MI 48075 or
email to employment@
glenncomputer.com

MANAGER

Part time for South



16 Offices to Serve You

Thousands of Success Stories!

LET US OPEN DOORS FOR YOU!

www.CENTURY21Town-Country.com



WAYNE A Honey For The Money
Great home in great neighborhood. 3 bedroom brick ranch w/ 4 appliances. Freshly painted throughout & immediate occupancy.

(E02HAY) 734 455 5600 \$127,777



LIVONIA Needs A Family!
Charming 3 bedroom 1.5 bath home w/ newer multi decked roof vinyl siding & updated windows. Large 2 car garage on extra large lot. Walking distance to shopping & schools.

(E39CUR) 734 455 5800 \$199,000



DEARBORN Historic Springwell 5 Park!
Absolute darling 2 bedroom home in highly sought out area. Surrounded by much higher priced homes. Must condition. Don't miss this rare opportunity!

(E8ABIN) 734-455 5600 \$162,500



ROMULUS Gorgeous 3 Bedroom
First time buyers this house is completely furnished see it for yourself! Beautiful kitchen with ceramic tile floor. 2 story great room kitchen cabinets ceramic floor custom lighting. Professionally decorated. Transfer forces sale of this beauty. A must see.

(E67EUR) 248-349 5600 \$124,900



NOVI Wonderful Ranch Home
Large ranch home on a double lot w/ wooded Lake privileges. 3 BR 2 full baths & whirlpool tub. Lots of fresh paint and carpet. Great access to freeways & 12 Oaks Mall. 1 car garage.

(E30PAR) 248-349-5600 \$230,000

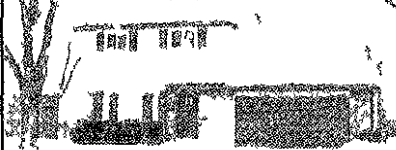

WESTLAND Great Corner Lot
Cute 3 bed room 1.5 bath colonial w/ 2 car attached garage part of 1st shed basement new kitchen cabinets newer carpet throughout & new windows & under w/ anty.

(E91FIL) 734 455 5600 \$139,900



WAYNE It Has All Been Done
4 bedroom bungalow w/ remodeled kitchen & cozy 1st shed basement. Updates include w/d vs furnace C/A electric roof & bath. Nice yard w/ shed & patio.

(E71NIA) 734 455 5600 \$124,999



DEARBORN HGTS Relax & Enjoy
Perfect starter home w/ all major updating done w/ windows kitchen roof furnace A/C electric & plumbing. Florida room covered deck & 2 car garage.

(E14GER) 734 455 5600 \$118,000



SOUTH LYON Golf Course Community
Custom home 4 spacious bedrooms. 1st floor master & 2nd floor great room kitchen offers cherry cabinets ceramic floor custom lighting. Professionally decorated. Transfer forces sale of this beauty. A must see.

(E02GRE) 248-349 5600 \$449,900



WEST BLOOMFIELD Chelsea Park Value
You will love all the goodies. 4 BR 3.5 BA colonial tucked away in forest of Chelsea Park on a cul de sac and backs up to woods. Grand fireplace in FR. Fabulous finished walk out w/ theatre area & bedroom or library.

(E90PEM) 248-349-5600 \$599,900

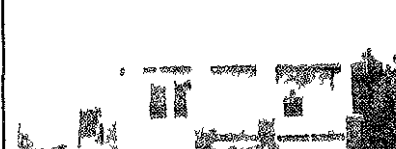

WESTLAND Very Nice Bungalow
With open floor plan huge updated oak kitchen hardwood floors new roof windows & nice large deck fenced yard.

(E01FLO) 734 455 5600 \$137,000



DETROIT Extra Clean Colonial
3 bed rooms 2.5 baths new kitchen & bath family room DR. Entry Marble tile mantel hardwood floors 1st bsmnt 2.5 car gar newer furnace roof & windows Sunroom & deck on double lot w/ 1st pond 1 yr HPP.

(E76LAK) 734 455 5600 \$110,000



NOVI Nestled In Novi
Updated 4 bed rooms 2 baths 2 car attached garage furnace & C/A 99 sq ft njrce 02 w/ nyl windows FR w/ frplc oak kitchen w/ Pergo tile doorwa to tiered deck DR ceramic foyer in baths freshly painted newer carpet.

(E00HEA) 734 455 5600 \$239,914



WESTLAND Welcome Home
Awesome 4 BR 2.5 BA colonial family home BR w/ wrlpc off w/ i appointed kit Door to multi tiered deck Finished walk out LL Terrific master ste 3 nice sized BR s Plenty of storage 3 car garage and more. Move right in.

(E43HEN) 248 349-5600 \$212,866



NOVI Rare 4 Bedroom Ranch
Rosa ranch best of everything quality ceramic crown molding 4 bedrooms family room w/ fireplace formal living room & dining room Newer kitchen counters partially finished basement and much much more.

(E82ROX) 248-349-5600 \$364,900



LIVONIA This Is It!
Ranch condo in the woods of Livonia 2 bedrooms 1.5 baths. Freshly painted & ready to move. Master w/ in WC Court sitting. Close to shopping & x ways.

(E08CLA) 734 455 5600 \$118,500

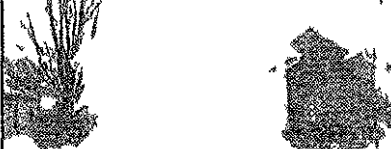

LIVONIA Great Investment
2 bed room 2 bath 2 car attached garage full basement 1st floor laundry fireplace in living room C/A. Must see inside this 1998 const. Act on.

(E88HAL) 734 455 5600 \$165,000



ALLEN PARK You Can Have It All!
Spacious & updated 3 bedroom brick ranch w/ 2 car garage 1st shed basement large BR w/ wrlpc sharp kitchen w/ all the appliances master bedroom w/ wood wall to deck & much more.

(E53GAH) 734-455 5600 \$159,000



PLYMOUTH Mint Condo
Prime 3 BR 2.5 BA colonial family home BR w/ wrlpc off w/ i appointed kit Door to multi tiered deck Finished walk out LL Terrific master ste 3 nice sized BR s Plenty of storage 3 car garage and more. Move right in.

(E77HID) 248-349-5600 \$389,900



CANTON Great Yard With Large Deck
4 BR 2.5 BA home w/ all the newer amenities. Some of them are roof w/ transferable warranty windows also Trans warranty gutters 2003 garage door fireplace in FR Remodeled kitchen 99 All appliances stay.

(E46SOM) 248-349-5600 \$211,900



GROSSE PTE WOODS Curb Appeal + Location
All active oak bungalow LR w/ oove ceiling vinyl estate opens to terrine DR K1 updated w/ oak cabinets in oven m/c stove top & breakfast ea. 1st shed basement w/ wrlc ba & 5 bath + ga age.

(E45HOL) 734 455 5600 \$193,500



WESTLAND Stop The Car
3 bedroom 2 bath cape cod w/ updated Pergo floor s newer ca pet & w/ ood m/d n g. Beautiful landscap ng w/ dyed cement.

(E26GLE) 734 455 5600 \$169,900



CANTON Important Work Done
Spacious home has much to enjoy such as the newer roof w/ windows full nose carpet & cement. Fireplace in fm y oom doorwa to backya d freshly painted & carpeted th s Ma ch Fenced yard & warranty.

(E24HAN) 734 455 5600 \$225,000



NORTHVILLE Smile, You Found It
Sharp 4 BR 2.5 BA colonial family home BR w/ wrlpc off w/ i appointed kit Door to multi tiered deck Finished walk out LL Terrific master ste 3 nice sized BR s Plenty of storage 3 car garage and more. Move right in.

(E57HOL) 248-349-5600 \$446,950



NORTHVILLE Large Colonial
Plenty of room many updates including newer carpet throughout paint appliances 4 bedrooms 3.5 baths w/ 6th bedroom in lower level Large shaded yard backs to commons.

(E03SPR) 248-349 5600 \$339,900



LIVONIA Condo Living At Its Best
Gorgeous brick townhouse in great location features include recessed ghts vaulted ca ngs fireplace & attached ga age. Bu t n 2001. A must see.

(E66FAR) 734 455 5600 \$182,900



SOUTHFIELD Character & Charm
Descibes this lovely 4 bedroom 2 bath brick cape cod w/ granite finished basement newer 2 car garage updated Pergo floor baths roof shingles C/A w/ ndows.

(E20COD) 734 455 5600 \$189,500



WESTLAND Like New
3 BR 1.5 BA ranch w/ many updates. Family room w/ fireplace & cathedral ceiling Newer kitchen baths Walls w/ windows track lighting Huge deck plus paver pat o 2 car garage and much more s.

(E25AVO) 248 349 5600 \$179,900



NORTHVILLE Incredible Value
Waterfront estate in Stonewater sub. Largest sq ft built by Mccorri upgraded marble granite cust cherry cabinets 2 story enclosed porch spiral staircase MBR w/ 3 way brick sitting rm & glamour bath Fin LL w/ kit bath & BR.

(E02MAN) 248 349-5600 \$1,199,000



WESTLAND Awesome Condo
Absolutely lovely & spacious ground level condo. Newly painted & carpeted w/ neutral decor Large LR w/ fireplace doorwa to patio overlooking beautiful pond w/ fountain A/C Livonia schools & immediate occup.

(E65WOO) 248-349 5600 \$69,900



NEW BOSTON Bright & Cheerful
Updated 4 bedroom bungalow w/ entry doors vinyl nace A/C ca pet & fresh paint. Oak kitchen w/ hardwood floors 1st floor laundry deck & ca ga age w/ newe doo.

(F45SIB) 734 455 5600 \$162,900



LIVONIA Location Location Location
Charming 3 bedroom 2 bath brick cape cod attached ga age family oom d n g oom fu nace 95 W a s de windows C/A a appliances n used immediate occupancy. Backs to school.

(E43MEL) 734 455 5600 \$225,900



WEST BLOOMFIELD Welcome Home
Sharp 3 BR brick W/D Updated bath w/ ceramic & whirlpool tub Andersen windows and doorwa. Freshly painted newer ca pet furnace A/C Newer well & city sewer s Newer Pe go to oo ng.

(E39CED) 248-349 5600 \$184,900



NOVI You Want It, We've Got It
All the most wanted features open floor plan 1st floor master fireplace finished lower level 4 bedrooms 4 baths 1st floor laundry large deck and wooded lot & sidewalks Northville schools Fresh paint.

(E88MYS) 248-349-5600 \$464,900



WEST BLOOMFIELD Fabulous Colonial
This home has all the bells and whistles. Granite in kitchen ceramic tiled & hardwood floors W/D wooded lot. Fireplace in FR 4 BR 2.5 BA 3 car garage grand MBR w/ huge WIC & dressing area Bonus Room FFL.

(E80YAR) 248-349-5600 \$549,900

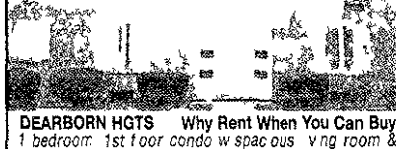

DEARBORN HGTS Why Rent When You Can Buy
1 bedroom 1st floor condo in spacious living room & dining room common basement w/ storage & laundry. Close to everything.

(E35COU) 734 455 5600 \$72,000



GARDEN CITY A Place To Call Home
3 BR bungalow offers LR w/ covered patio plastic w/ s & bay window eat n kit + DR hwdw i s under crpt. New vinyl windows roof + C/A fenced yard & deck. Fin tsmnt w/ woodbu n ng stove & 2 car gar.

(E46JOH) 734 455 5600 \$143,500



MILFORD Country Living
Great mix of new and old. Updated farmhouse w/ kpt HW floors & o g ne woodwork. Large shed/work shop for hobbyist. Acres of trees f owa s and room to play. Home wa nty provded.

(E25CHA) 248 349 5600 \$204,750



NORTHVILLE Beautiful
Updated 5 BR 3.2 BA colonial on approx 5 wooded acres. Updates include kit flooring roof furnace A/C & more. Great floor plan FR w/ rplc formal DR Large media rm All season rm w/ rplc & wet bar 5+ car gar.

(E00NAP) 248-349-5600 \$759,900



NORTHVILLE Walk To Downtown
Clean open wall maintained townhome. Huge master w/ walk in 3 BR 2.5 BA Large 1st bsmnt 2 car att gar gas trplc FFL Gorgeous stone patio pool & clubhouse. Heat & water included in associat on dues. Pets are ok.

(E02SAR) 248-349-5600 \$210,000



DEARBORN HGTS 4 Bedroom Brick Cape Cod
With 1st shed bsmnt & oods of cha acte. 2.5 baths 18x20 covered back porch newe C/A & oof 2 ca garage w/ opene & plenty of storage. Clean & we cared fo. Newer flooring n kitchen Bath on a floors.

(E72SIL) 734 455 5600 \$185,000



CANTON Don't Miss This One!
New paint n h s ovel 3 bedroom 1.5 bath cape on a condo. Kitchen has light cabinets pantry & breakfast ba. Spacious rooms dining room ove looking common area large basement & carport.

(E74FRA) 734 455 5600 \$145,900



SOUTH LYON Golf Community
4 BR 2+2 BA cape cod w/ oof i view in front & nature preserve n back. 1st floor master. Large gourmet kitchen 2 story great room w/ gas fireplace. Finished walkout bsmnt w/ loads of storage. South Lyon Schis.

(E00COU) 248 349 5600 \$579,900



REDFORD Picture Perfect
Better than renting 3 bedroom ranch with newer white kitchen furnace A/C roof concrete landscaping and windows updated. Soft neutral colors throughout. Move in condition.

(E28NOR) 248 349-5600 \$117,900



CANTON Spacious Condo
Very neat & clean 3 BR 2.5 BA 2 story unit. Neutral decor w/ DR has doorwa leading to your large deck. Partially finished basement w/ rec room & add'l rm for office or extra storage. Lg kit w/ brkfst nook.

(E79SAR) 248-349-5600 \$205,900



PLYMOUTH Character & Charm
Plus cu b spaces n th s 3 BR 2 BA bungalow w/ updated kitchen w/ maple cabinets & app's part n bsmnt master ste w/ updated bath & h s & har WIC newer oof s ding & tr m. Plus t eed ya d v n erad steps & paver pat o.

(E76BUR) 734 455 5600 \$284,000



YPSILANTI A Real Find!
Sold by ck 3 bed oom anch w/ mecharca d eam 2 car ga age. Updated kitchen newer furnace windows & roof. Updated bath w/ etted tub. A so appliances.

(E41HEA) 734 455 5600 \$139,900



SOUTH LYON Trotter's Pointe Village
Super sharp 1999 but it colonial 2 car attached garage FFL 1999 built colona. Basement fireplace in FR hardwood floor spr nke s deck MBR w/ BA letted tub & separate showe. Appliances & home warranty includ.

(E51COL) 248 349 5600 \$259,900



REDFORD Ranch On Corner Lot
Great looking 3 bedroom home. Breezeway provides a bonus room for an office or den. Privacy fenced yard. Lets you enjoy the above ground pool all summer.

(E05NOR) 248-349-5600 \$139,000



WEST BLOOMFIELD Gorgeous Contemporary
4 BR 3.5 BA home on wooded lot w/ fully finished W/D LL Island kitchen newer neutral carpet ceramic floors wet bar volume ceilings & skylights. Master bedroom w/ huge WIC 2 furnaces 2 A/C units. Fantastic!

(E48WAT) 248-349-5600 \$424,900

Relocation Services 800-448-5817

Birmingham 248-642-8100	Clarkston 248-620-7200	Commerce Twp. 248-363-1200	Northville 248-349-5600	Rochester 248-652-8090	Royal Oak 248-280-4777	Troy 248-524-1600	West Bloomfield 248-626-8800
Plymouth 734-455-5600	Grosse Pointe 313-886-5040	St Clair Shores 586-778-8100	Shelby Twp. 586-731-8180	Chesterfield Twp. 586-949-5590	Clinton Twp. 586-286-6000	Fraser 586-294-3655	Sterling Heights 586-939-2900

ONE NEW WEBSITE ALL THE HOMES OVER 30,000 PROPERTIES

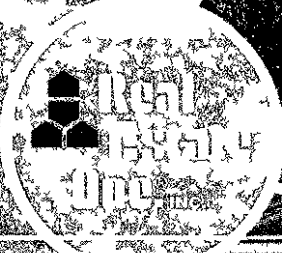

www.realestateone.com

The Real Estate One Family of Companies: Real Estate One, Max Brook Realtors, Johnstone & Johnstone, John Roberts, The Age of Real Estate



NOVI \$664,900
A HOUSE BEAUTIFUL DESIGN Magnificent home elegant LR & DR gorgeous kit & brkfst area w/great views of the wood lib spacious FR 4 lg BRs charming MSTR suite A remarkable palacel! (57HIL2)

248-348-6430

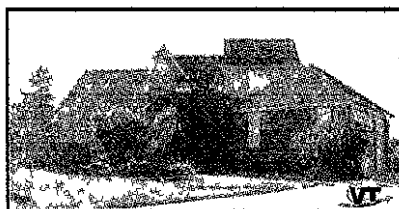

CANTON \$419,900
LOCATION! LOCATION! LOCATION! Rare find! Enjoy court location which backs to a pond w/ fin Mstr 1st flr 3 car gar w/heat W/O brnt den off foyer hrwd frs in kit foyer nook & hilwy (B47539)

734-591-9200



PLYMOUTH LAKES \$414,900
ANDOVER LAKES SPECTACULAR! Stunning 4 bedroom colonial tastefully decorated & ready to move in Finished walk out basement with 5th bedroom This home is priced to sell! (23W13241)

734-455-7000



HAMBURG \$409,900
WHAT A BEAUTY! Super maintained brick col on superb 1 acre lot w/wooded backdrop 4 BRs 2 1/2 baths deep bsmt 3 car gar patio Terrific mstr ste what are you waiting for? (23O7807)

734-455-7000



PLYMOUTH ACREAGE \$389,290
3 PLUS! Plymouth mailing P y mouth schools Washitenaw taxes Brick ranch 3 bdrms + in law ste 3 full baths Bsmt pole barn Fantastic view w/corral Many updates (23J9290)

734-455-7000



NOVI \$348,500
GREAT HOME CLOSE TO SCHOOLS Charming home w/updated kit & brkfst area formal lr & dr fr w/frpl & built in bookcases fin d bsmt w/lots of storage & full bath And 4 seasons sunroom (60MAN2)

248-348-6430



NOVI \$325,000
GREAT OPEN FLOOR PLAN! 4 bed 2 1/2 bath colonial freshly painted neutral in most rooms Fam Rm has fireplace & wet bar Partial finished LL w/2nd Fam Rm & workshop Many updates (60HUN2)

248-348-6430



NOVI \$312,900
EYE CATCHING RANCH SITUATED ON GREAT LOT Comfortable home backing to woods spacious gr w/cathedral ceiling & frpl 3brs 2 full baths pleasant kit & brkfst area nicely fin d bsmt & deck (72PHI2)

248-348-6430

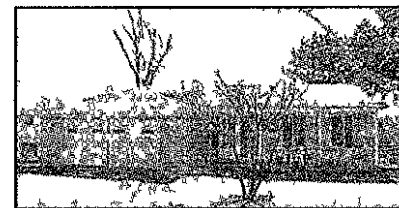

LIVONIA \$279,900
1/2 ACRE PLUS YARD IN LIVONIA Updates include new furnace roof and windows Pride of ownership shows Hardwood floors kitchen has updated counters & flooring and huge walk in pantry (01PIC2)

248-348-6430

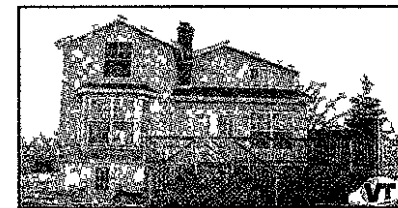

CANTON \$264,999
RENOVATED FARM HOUSE Country living w/ all the Finest upgrades Beautiful cape cod style with 4 bdrms 2 bath stone fireplace in great rm finished walkout Basement and awesome lot (R814)

734-326-2000



NORTHVILLE \$264,900
NORTHVILLE BEAUTY One owner 4 bedrooms Quality updates have been maintained Two baths cozy fireplace home office and a lovely private yard (32LAN2)

248-348-6200



PINCKNEY \$250,000
BEAUTIFUL AND SPACIOUS PINCKNEY COLONIAL Newer corian kit w/ stainless appliances 3 BRs 2 1/2 BAs lg GR w/frp formal DR w/bay window mstr bath w/jacuzzi fin bsmt 3 car gar great deck backs to commonst! (87VIN2)

248-348-6430



NOVI \$250,000
IMMACULATE UPDATED HOME-GREAT LOCATION This charming home is ready to move into Many updates include windows kitchen baths flooring lighting fixtures window treatments and landscaping 4BRs 2 BAs (11SYC2)

248-348-6430



CANTON \$249,900
WHY BUY NEW? Check out 3yr old unit w/many expensive extras Premium lot prof fin walk out lower level 1st flr master 2 additional BRs & den upper 2 FPs (P1886)

734-591-9200



FARMINGTON \$227,900
NOT A DRIVE BY! MUST SEE! Farmington 4 BR 2 1/2 bath Ranch! FR w/frpl full bsmt some hwd frs over 1 500 SF 20 foot covered patio 2 car attached garage & gorgeous private back yard! (02MAP2)

248-348-6430



PLYMOUTH \$220,900
FABULOUS BARBERRY UNIT! 2 story ceiling makes this LR inviting FR w/adj powder rm Can be bit as 3rd bdrm Avail upgrades Ext Indesp sprnkrl sys lawn main & snow remov Prime locat (23A1205)

734-455-7000



LIVONIA \$212,900
UPDATED & MAINTAINED TO PERFECTION! 5 & Newburgh ranch offers open fr plan w/2 car attached garage fin bsmt Custom updated kitchen baths rf furn & more (J38751)

734-591-9200

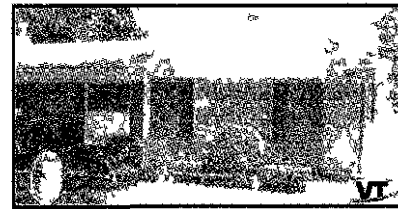

PLYMOUTH \$199,900
UPDATED PLYMOUTH TOWNSHIP HOME! Walk to local elem school or walk to Hines Park either way this charming ranch has loca tion all over it Full basement 2 car det gar FR w/a FP & tons of updates (H11520)

734-591-9200

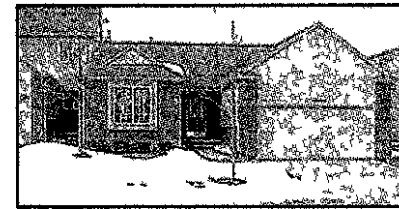

HARTLAND \$195,900
FABULOUS HARTLAND CONDO Desirable end unit ranch condo Great rm w/vaulted ceiling & gas fireplace Spacious kit w/island Park like setting from deck w/ retractable awning Very clean! (04NOR2)

248-348-6430



PLYMOUTH \$194,900
THE ARBOR has an open fr plan Fin lower level rec rm next to laundry & powder rm Townhome comm will feature Indesp sprnkrl sys lawn main/snow remov Low asso fees (23A1205)

734-455-7000

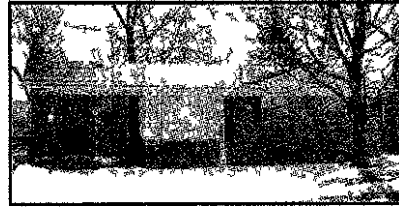

LIVONIA \$194,900
LIVONIA UPDATED RANCH! Spacious 3 BR 2 full bath ranch on a great interior fenced lot Newer furnace A/C roof kit & bath Great finished bsmt w/frplc wet bar & huge storage (23H29655)

734-455-7000



NORTHVILLE \$179,900
CONVENIENCE STYLE & FUNCTIONALITY! Immediate occupancy in this end unit with all appl incl New berber carpet paint & lg Indry rm w/lots of storage Neutral decor 1 car gar fin bsmt Hurry! (G21228)

734-591-9200



LIVONIA \$174,990
MOVE IN AT CLOSING! Full brk ranch cathe dral ceilings thru out 3 BRs 1 1/2 baths on main flr newer wndws elec & plumb c/a bsmt has wet bar 2+ car garage Hurry wont last!! (O19184)

734-591-9200



WESTLAND \$169,900
BEAUTIFUL BROWNSTONE CONDO Comfortable living on all 3 floors Bay windows on 1st & 2nd floors fireplace hardwood floors near shopping & restaurants Must see to appreciate! (C677)

734-326-2000



WESTLAND \$159,500
BEAUTIFUL BRICK RANCH Updated brick ranch Updated Kitchen custom cabinets & counters Awesome Bath with his/her sinks w/ new ceramic tile Hardwood floors finished Finished basement (F744)

734-326-2000

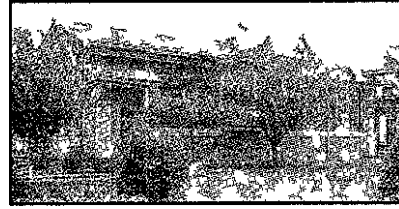

NOVI \$156,000
RANCH DETACHED CONDO Great 2 BR carriage unit w/1 car direct access garage new windows carpet neutral decor Very open floor plan Move right in! (45PEL2)

248-348-6430

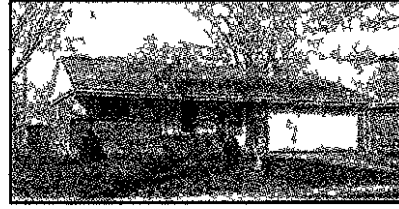

WESTLAND \$154,900
BUY TODAY MOVE TOMORROW Into this 3 bedroom Tomcoish Sub brick ranch full basement family room with fireplace 2 car attached garage and central air (T340)

734-326-2000



GARDEN CITY \$149,999
COMFY CAPE COD Is this 3 bedroom brick home in Garden City? 2 full baths 3 car garage Lots of nice features newer windows doorwall to deck double lot (M319)

734-326-2000



DEARBORN \$141,900
WHAT A BEAUTY! Imagine a home you can move into without doing a thing! Updates include lg kit newer furn & hwh new half bath in bsmt newer wndws & a FP in living rm (W15491)

734-455-7000



REDFORD \$139,900
SOLID BRICK RANCH! In area with brand new homes Within a block of Lawson Field offers tennis basketball & play area Nice floor plan with finished basement (L19158)

734-591-9200



REDFORD \$139,900
YOU'VE BEEN WAITING AND HERE IT IS! This updated & inviting home sides to park and elementary school Situated in one of Redford's finest areas New furn air rf gutters plumb wndws & more! (D15651)

734-591-9200



LIVONIA \$129,900
ALL BRICK RANCH WITH FINISHED BASEMENT! Big kitchen hardwood floors that need refinishing 3 windows left to replace C/A 4 yrs old bathroom has double sinks patio in back is brick & more! (H150)

734-326-2000



REDFORD \$129,900
WELL MAINTAINED BROAD FRONT BUNGALOW 3 BRs fin bsmt w/bar new kitchen countertop new glass blk wndws newer carpet thru out bay window fenced yd 1 1/2 car attd garage Lg pie shaped lot & more! (L19507)

734-591-9200



REDFORD \$124,900
LOOK NO FURTHER! Great home with lots of space! Lg lot bsmt & attd 2 car garage updated lg kit newer furn & hwh new half bath in bsmt newer wndws & a FP in living rm (W15491)

734-591-9200

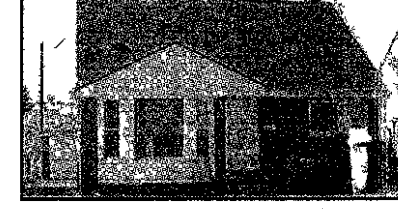

INKSTER \$119,900
UPDATES GALORE! This 3 bedroom brick home with finished bsmt & 1 1/2 car garage features newer roof windows furn C/A plumbing circuit breakers & more Clean & Bright! (A620)

734-326-2000



REDFORD \$114,900
SWEET SWEET SWEET 3 BR bungalow loaded w/updates A pleasure to see Very clean and well maintained Maintenance free exterior Lovely landscaping Call to see (K20470)

734-591-9200



REDFORD \$114,900
LOCATION QUALITY, VALUE & CHARM! 3 BR bungalow has it all Updates include rf furn a/c bath rm elec vinyl siding All kitchen appliances stay along w/washer & dryer One yr home warranty (G17430)

734-591-9200

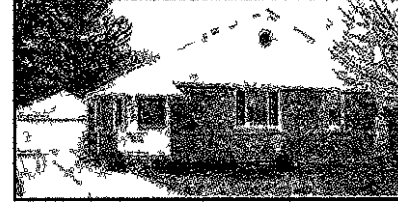

REDFORD \$109,000
WHY RENT! OWN A MOVE IN CONDITION RANCH 2 bedrooms 1 bath 2 1/2 car garage & shed Hwd frs curved archways lots of storage & many updates All this and a golf course view This one is ready to go (75GAR2)

248-348-6430



INKSTER \$99,900
EVERYTHING IS DONE! Newer windows roof garage furnace & C/A 3 bedrooms 2 full baths partially finished basement Really nice house w/garage & carport (N123)

734-326-2000



WESTLAND \$79,900
A GREAT START IS YOURS In this alum num Westland ranch With country kitchen and covered carport Newer roof shingles & covered patio Complete the package (B334)

734-326-2000

HOWELL \$419,900
ELEGANT CONTEMPERARY! 1st flr master gourmet kitchen hardwood throughout 1st level 3 1/2 baths 3 car garage Private beach across the street All sports lake access! A real beauty! 23L3354

734-455-7000

SOUTH LYON \$298,000
NEW CONSTRUCTION 1/2-3/4 ACRE W/O SITES Only a few sites remain in this 24 unit project All sites are 1/2-3/4 acre walk outs Quality built construction with our plans or yours 05PON2

248-348-6430

GARDEN CITY \$204,900
BEAUTIFUL NEW CONSTRUCTION! Wow! Builder built this one in Livonia last and it sold before we could finish it! Mstr 1st flr vaulted GR ceilings 2 car attd gar 70x145 lot H1731

734-591-9200

CANTON \$189,900
THIS HOME IS A 10! Spottless 3 BR 2 BA ranch w/beautiful new oak kit 6 panel oak doors updated bath new windows roof and more! Family rm has nat fp full bath in basement 20ALL2

248-348-6430

LIVONIA \$105,000
Perfect as a starter! 2 bedroom ranch Big lot with carport All appliances newer kitchen & bath freshly painted newer roof One year home warranty Needs a little TLC C11788

734-591-9200

Call Info Line at 888-REO-11ST, punch in the PC code to go in our home

interview.

CUSTOMER SERVICE PROFESSIONAL:

Find yourself in a fun, challenging career that maximizes your people skills. Herrybeck Publishing currently has positions available for experienced telephone service representatives who know the value of a smile, pride themselves on patience, and keep going until the customer is happy. Call 000-0000 for a preliminary telephone interview.

CUSTOMER SERVICE PROFESSIONAL

There's

trust

in classified advertising!

Newspaper classified advertising is the most reliable source for finding and sharing opportunities.

Whether your newspaper is delivered to your doorstep or your computer, you can always count on your Observer and Eccentric classified section to bring you the best local classifieds around.

In print or online, when you come to The Observer & Eccentric Newspapers, you come to the right place. It's what you trust!

We work for YOU!

For the best in local
classified advertising visit
www.hometownlife.com

Observer & Eccentric

1-800-579-SELL



Jobs and Careers

All Ads Run Online
FREE!
A Value Of Up To \$87.00
www.hometownlife.com

This Classification continues from Section F

Help Wanted-General 5000

SPA DIRECTOR MAKE UP ARTIST COSMETIC SALES MASSAGE THERAPIST HAIR STYLIST

Must have experience Mira Linder Spa 248 877 1441

Help Wanted-General 5000

SPRAY APPLICATORS

needed \$13 & up based on exp Tree trimmers & ground staff \$9 to \$16 + based on exp Must have a valid drivers license with a good driving record Exp benefit package available Mountain Top Tree Service Northville 248 349 1870

SPRING COILER

Experience with 2 pin coil Excellent comp package American MSC 248 589 7770 ext 109

STOCK & FLOOR DISPLAY PERSON

Michigan Design Center Furniture Showroom in Troy needs a part time stock and floor display person Must be able to lift 70 lbs Duties include receiving freight opening and tagging merchandise light housekeeping and filing moving display items and wrapping sold items for customers Must work with minimal supervision Approx 20 hours a week (daytime no weekends) but may expand to full time Fax resume to 248 822 8300 or email to info@rthomastid.com

STOCK PERSON (FULL TIME)

Lighting showroom Benefits good working conditions Experience preferred Apply in person BROSE ELECTRICAL 7 Mile & Newburgh Livonia 734-464-2211

STRUCTURAL STEEL ESTIMATOR

For Building Supply Company in Redford/Livonia area Ability to do shop drawings a plus Must be able to accurately do take offs with blueprints along with material lists for structural steel Salary negotiable Competitive benefit package Send resume to Estimator c/o 2558 Pine Drive Wixom MI 48329

SUMMER POSITION

Day camp director with leadership skills needed exp in camps routines/procedures including planning scheduling & implementation of activities supervision of staff & exp working with children Camp runs from June 6-Aug 19 Pre camp work available Call 248 661 3630

TEACHER ASSISTANT

Sought for Farmington YMCA infant/toddler/pre school program Call Mary Beth at 248 553 1909

Teachers Counselors Art Sports Drama & Science Instructors

Pool Directors WSI's & Lifeguards Needed for day camps with locations in Oakland County Must be enthusiastic & exp Call 248 661 3630 248 357 1740

TEAM LEADERS

TARGET NOW HIRING TEAM LEADERS

We are seeking outgoing self motivated individuals with supervisory skills and prior retail experience to join our team We offer on the job training competitive salary and benefits Discounts at Target Servicos and Marshall Fields Please send or fax resumes to Attn: ETL TR 21400 Northwestern Highway Southfield MI 48075 Or (248) 248 423 4202 ext 394

TELEMARKETERS

\$7/hr + bonuses 4pm-8:30pm Mon Wed Thurs 4pm-9pm Tues 5am-5pm Sat 734 402 2515

TELEMARKETING

\$8-\$15 Per hour + bonuses Telemarketing / mortgage exp helpful Full/part time Call Bob RG Enterprises 248 613 7444 or fax resume 248 681 4952

Help Wanted-General 5000

TEMPORARY COMMUNICATIONS SPECIALIST (MUNICIPAL SERVICES)

Canton Township is accepting applications for Temporary Communications Specialist (Municipal Services) Responsible for planning organizing and implementing Township communications developing public relations preparing multi media materials and presentations Must be proficient in the use of a personal computer training in desktop publishing graphic design techniques photo manipulation software and presentations software preferred Bachelors Degree in Communication Arts Community/Public Relations English/Journalism or a related field 20 hrs/week Salary \$22.20/hr application can be picked up at the Canton Township Human Resources Division 1150 S Canton Center Rd An application form is also available on the Canton Township website at www.cantonmi.org A Canton Township application form must be completed in its entirety and the form must be received in the Human Resources Division prior to 4pm March 31 2004 No resumes will be accepted without written application form The Charter Township of Canton does not discriminate on the basis of race color national origin sex religion age or disability in employment or the provision of services An Equal Opportunity Employer

TITLE EXAMINER PROCESSORS & ACCOUNT REPS

Needed for established title agency Exp pay & high commission rates Seeking exp & organized individuals Please fax resume to 248 832 4133

TITLE INSURANCE INDUSTRY POSITIONS

ALL positions available in many locations Qualified professionals with experience Please fax resume to 248 649 4123 or E-mail mpratt@qscorp.com

TOOL SHOP ASSISTANT

\$10-\$12/hr Farmington Hills 3240 Hrs/wk Mechanical ability req shipping/receiving shop clean up Some lifting Fax 248 471 1156

TREE CLIMBER

Tree service in Farmington area seeks a climber Must have exp & drivers license Budget Tree 1 800 964 7785

TRUCK DRIVER

CDL Class A Detroit/Chicago Home nightly Exp required (313) 580 8589

UPSCALE PUBLIC GOLF COURSE

hiring for the following positions Pro Shop Starters Rangers Cooks Dishwashers & Grounds Crew Golf linkages Apply in person at THE LINKS OF NOV1 50395 W 10 Mile Rd Novi (1/4 mile W of Wixom rd)

VOLUNTEER DRIVERS

Needed for Meals on Wheels in Troy Please call between 9am-2pm 248 546 2700

VP MEMBER SERVICE

LOC Federal Credit Union seeking VP of Member Service Responsible for both Cash/Member service Department IT exp is a must Eservices background expected Management exp required Solid compensation/benefits package Send resume to VIM Member Service LOC Federal CU 22981 Farmington Rd Farmington MI 48336 Or email kmccoll@locfederal.com

WAREHOUSE

For Genesee Ceramic Tile in Farmington Hills Must be detail oriented dependable & familiar to fast paced environment Full time Fax resumes to 248 476 7067

Warehouse

In Troy needs personnel Full time benefits Day shift Apply at 600 W Maple Rd Mon Fri 9-4

Welder/Mechanic Experienced

Needed for repair & fabric cation shop Must have own tools Knowledge of trailers helpful Excellent wages & benefits RESUMES ONLY 7780 Ronda Drive Canton MI 48187

WILLIAM D FORD TECHNICAL CENTER

Position open as follows PT Computer Instructor Ford Skills Enhancement program Mon & Tues 3pm-6pm Posting closes April 1 2004 For information call Ginny Kowalski 734 419 2106 Apply in person at Wayne Community Schools 36745 Marquette Westland EOE

Help Wanted-General 5000

Writer/Editor

Our dynamic service oriented organization needs an enthusiastic team player eager to grow this position The National Truck Equipment Association is seeking a candidate with strong copy writing/editing skills to produce several monthly and quarterly newsletters as well as communications with a variety of media Candidates with PageMaker and layout experience will be given added consideration Send resume Gwen Brown Communications Director NTEA 37400 Hills Tech Drive Farmington Hills MI 48331 9414 fax (248) 489 8590 or gwen@ntea.com

Help Wanted-Computer/Info Systems 5010

Computer Programmer

Part time Knowledge in Visual Basic Access 97 Visual Studio a plus Good pay and flexible schedule Perfect for college student majoring in CIS

Robot Printing and Communications 12085 Dixie

Redford MI 48239 (313) 255 0470 FAX humanresources@robotprinting.com

WEB DEVELOPER

Full time for commercial web application developers Strong background in HTML and experience in server side scripting and SQL a must Great pay and flexible hours

Robot Printing and Communications 12085 Dixie

Redford MI 48239 (313) 255 0470 FAX humanresources@robotprinting.com

Help Wanted-Office Clerical 5020

Accounting PERSONAL ASSET MANAGER

Strong background in accounting and finance required Candidate must have above average interpersonal skills With job training and experience qualified candidate may become the corporate interface for this exciting ideal candidate is highly independent has a wide range of abilities and is flexible with time This job offers unique exciting and challenging projects to be completed in a variety of settings Familiarity with trusts and high end personal tax a must MPA degree preferred Resumes only please to Marie Johnston HR Department Real Estate One 25800 Northwestern Hwy Southfield MI 48075 Benefits EOE

Legal Senior Secretary

For Southfield PI law firm Minimum 3 years experience Windows/Microsoft Word knowledge a must Salary commensurate with experience Send resume to Sherry Sinnott 2928 Crooks Road Royal Oak MI 48073

LEGAL SECRETARY/RECEPTIONIST

Full time entry level for Birmingham law firm MS Word experience Salary plus benefits Fax resume to Karen at (248) 642 1949

ACCOUNTS PAYABLE/RECEIVABLE

And Payroll Part time temporary position late May through August Fax resume to 734 729 7776

ADMINISTRATIVE ASSISTANT \$35,000 to \$40,000

Friendly suburban firm Strong Word Excel and PowerPoint Light accounting experience Call Donna 586 772 6760 Snelling Personnel Services

ADMINISTRATIVE ASSISTANT

For commercial real estate firm in Southfield Town Center Word Excel exp necessary Full time Fax resume 248 262 8315 or email lsmith@evismith.com

BOOKKEEPER Full Time \$30,000 to \$40,000

Some accounting knowledge to work with CPA & management Commerce Twp Send resume with cover letter to 248 360 9978

Data Entry COULD EARN \$15/hour and up!

Medical Billing Training Provided PC Required Call 7 days 1 800 935 1311 ext 308

Is it time for you to sell that car? Call your Observer & Eccentric Newspaper! 1-800-579-SELL

RECEPTIONIST

Walterwood at University a new or apartment community in Rochester Hills is seeking to fill a part time Receptionist position Candidates must be able to work flexible hours including evenings and weekends Applicants must be caring have the ability to work well with the public and have basic computer skills Apply in person at 3250 Walton Blvd Rochester Hills MI 48309

RECEPTIONIST

Part time Victory Honda Plymouth seeks outgoing individual as part time receptionist Sat & some evenings required Please apply in person 315 Ann Arbor Rd or call 734 453 3600

RECEPTIONIST

Needed for busy Title Company Full time w/ full benefits included Fax resume to Kristyn at 734 427 8185

Help Wanted-Office Clerical 5020

HENROB WORLD LEADERS IN FASTENING TECHNOLOGY

HENROB is a world leader in self piercing riveting technology and a supplier to the automotive truck and appliance industries Due to retirement we currently have an opening for an ADMINISTRATIVE ASSISTANT/RECEPTIONIST The position requires a High School Diploma or equivalent with at least five years secretarial experience The successful candidate will be well organized with the ability to handle multiple tasks projects include professional demeanor superior telephone skills proven track record of taking initiative and working independently Strong computer literacy in Microsoft Word Excel and Power Point and data entry accuracy/speed (50 wpm) are highly desirable Cheerful can do approach to problem solving and ability to work well with others is also essential This position offers excellent health dental life disability 401(k) and vacation plans together with a competitive compensation package with opportunities to grow If you are interested in becoming part of a team oriented organization with unlimited potential please forward a resume with salary requirements to

HENROB Corporation Attn Human Resources 22655 Heslop Drive Novi MI 48375 Fax (248)344 0184 E mail jobs@henrob.com

LEGAL SECRETARY

Southfield personal injury firm seeks minimum 2 yrs exp WordPerfect Salary commensurate with exp Fax resume to Office Manager 248 592 0376

LEGAL SECRETARY/RECEPTIONIST

Full time entry level for Birmingham law firm MS Word experience Salary plus benefits Fax resume to Karen at (248) 642 1949

Legal Senior Secretary

For Southfield PI law firm Minimum 3 years experience Windows/Microsoft Word knowledge a must Salary commensurate with experience Send resume to Sherry Sinnott 2928 Crooks Road Royal Oak MI 48073

LEGAL SECRETARY/RECEPTIONIST

Full time entry level for Birmingham law firm MS Word experience Salary plus benefits Fax resume to Karen at (248) 642 1949

OFFICE ASSISTANT

For local home improvement co A college degree is required w/ a strong emphasis in accounting Successful candidate will have exp in managing people & general office procedures You must be trained in Word Excel & PowerPoint We are a growing co & need someone who can improve our operation & be part of our growth Salary based on exp Email resumes oreumee@homecomm.net Code# 08 3040

OFFICE ASSISTANT

Part time for psychological clinic Knowledge of medical claims and insurance benefits preferred Tues Wed & Fri with some flexibility Fax qualifications to Debbie at 248 642 5739

OFFICE ASSISTANT

Part time Mon-Fri days for human services office in Canton entry level Need good communication skills ability to operate communication equipment including computer skills \$8.50 per hour Submit application at 32231 Schoolcraft Rd Ste 200 Livonia (734) 458 8140

OFFICE HELP NEEDED

General office Price & cost abilities computer skills a must Part time Call Ron 734 728 0795

RECEPTIONIST

For busy non smoking Southfield law office Min 2 yrs exp Fax resume to 248 553 8719

RECEPTIONIST

Walterwood at University a new or apartment community in Rochester Hills is seeking to fill a part time Receptionist position Candidates must be able to work flexible hours including evenings and weekends Applicants must be caring have the ability to work well with the public and have basic computer skills Apply in person at 3250 Walton Blvd Rochester Hills MI 48309

RECEPTIONIST

Part time Victory Honda Plymouth seeks outgoing individual as part time receptionist Sat & some evenings required Please apply in person 315 Ann Arbor Rd or call 734 453 3600

RECEPTIONIST

Needed for busy Title Company Full time w/ full benefits included Fax resume to Kristyn at 734 427 8185

Help Wanted-Dental 5040

CANTON DENTAL OFFICE

Seeking compassionate professional to join our front desk team Multi tasking skills minimum two years exp Dentech knowledge a plus Full time with benefits Fax resume to 734 981 0370

DENTAL ASSISTANT Full Time

Experienced needed for team oriented practice in Redford Please call 313 533 3300 or Fax resume to 313 533 3969

DENTAL ASSISTANT EXPERIENCED

25-32 hrs Benefits Westland/Livonia area 734 522 4470

DENTAL ASSISTANT

Full time position Dental experience required Excellent compensation Send resume 734 464 4778

DENTAL ASSISTANT

Must be experienced W Bloomfield Full time \$15 \$20/hr (248) 851 2980

DENTAL ASSISTANT

30 hours Will train responsible energetic person Livonia office 734 542 4999

DENTAL ASSISTANT

Quality Livonia family practice seeks friendly skilled person 4-5 days (734) 427 4525

DENTAL ASSISTANT

Full time position Dental experience required Excellent compensation Send resume 734 464 4778

DENTAL ASSISTANT

Join our expanding practice in the Commerce/W Bloomfield area Full time Experience preferred Call 248 363 5600

DENTAL ASSISTANT

Plymouth office seeking energetic self motivated experienced full time Dental Assistant 30.35 hrs/wk Resume required w/references Come join this fun team Call (734) 453 8650

DENTAL ASSISTANT

Stimulating wonderful work environment Benefits for experienced assistant in high quality specialty practice Give us a call! 248 357 3100

DENTAL ASSISTANT EXP

Busy friendly patient centered Canton practice Must be enthusiastic Exp salary & benefits 248 981 4246

DENTAL ASSISTANT/FRONT DESK

Are you an outstanding dental assistant/receptionist who appreciates being part of a team? Then we are looking for you For this career you must bring your outstanding customer service skills your computer literacy advanced phone skills and above all dedication Exp preferred or will train You know dentistry is 90% people skills and that reception is a critical area of the practice Part time Commerce Twp If this position sounds like you please call 248 363 2025

DENTAL CERAMIST

Experienced Build grind stain Knowledge of Empress helpful Immediate opening great pay benefits 734 671 6593 734 657 4062

DENTAL CERAMIST

Experienced Build grind stain Knowledge of Empress helpful Immediate opening great pay benefits 734 671 6593 734 657 4062

DENTAL HYGIENIST

Farmington Hills contemporary dental office seeking dental hygienist 27-30 hrs/wk Mon thru Thurs Call 248 855 3655

DENTAL PATIENT / COORDINATOR

Full time Dental & computer experience required Laurel Park Livonia Excellent environment Send Resume 734 464 4778

Dental Staff

Fabulous Garden City dental office looking to add staff to our continually growing practice If you are an experienced assistant/lab tech or front desk staff person please fax your resume to Michael Riech DDS at 734 522 4043 or email to mreichdds@hotmail.com

Hygiene Assistant/ Sterilization

Full time for a busy pediatric dental office in Novi Need detail oriented friendly outgoing person No eyes Some Sats Benefits 248 478 3232

ORTHODONTIC ASSISTANTS- LIVONIA

Our progressive orthodontic office is searching for a dynamic individual to join our team Prior ortho/dental background preferred full time with benefits Salary commensurate with experience Send your resume with your salary requirements to Attn Patti at 33627 Seven Mile Livonia 48152 or fax to (248)471 4146

Help Wanted-Dental 5040

ORTHODONTIC

Seeking skilled pleasant and enthusiastic Assistant Self motivation and an eye for quality and detail is most desired Please send resumes to Box 0842 Observer & Eccentric Newspapers 36251 Schoolcraft Livonia MI 48150

Help Wanted-Medical 5060

CARDIOLOGY TECHNICIAN

Exp in stress testing arrhythmia knowledge a must Full time for busy cardiology office Call Carrie 248 552 9858 or fax resume to 248 552 9510

DIRECT CARE STAFF

Part time Starting \$7.46/hr WCLS TRAINED ONLY! Livonia area Contact Debbie at 734 524 1361

Feelings You Can Trust

HCR Manicare one of the country's leading providers of long term and acute health services is dedicated to providing quality care in a supportive compassionate environment We currently seek

DIRECTOR OF NURSING

Danto Family Health Care Center a 65 bed skilled nursing facility is looking for an RN with strong clinical and management skills to lead our team of experienced nurse managers nurse supervisors and nurse aides and Qualifications for this position include

- Current valid RN license
- 2 yrs DON experience

Full time competitive salary excellent benefit package Please fax resume to 248 788 7141

Danto Family Health Care Center 6800 W Maple Rd West Bloomfield MI 48022 248 788 5300 EOE M/F/V/D

FRONT DESK CLERK

Entry level full time position available at multi doctor Internal Medicine office in Troy Fast paced physically stimulating environment Accepting faxed resumes ONLY 248 267 5001 Attn Kat

FRONT DESK PERSON

For Garden City physician's office Medical background preferred Fax resume to 734 762 8682

LICENSED PHYSICAL THERAPIST

Exp in outpatient clinic Females welcome to apply 248 225 4351

LPN OR MEDICAL ASSISTANT

Busy urology office needs nurse 25-30 hours per week Urology experience preferred medical office experience required Send resume to Dawn at 734 434 8777 or to dawcar@sboglobal.net

MEDICAL RECORDS RECEPTIONIST

Full Time Livonia MI Michigan Heart PC is a leader in cardiovascular care for southeastern Michigan We firmly believe that every member of our team plays a significant role in the care of our patients We offer a competitive salary and great benefits

- Responsibilities**
- Patient check in & check out
 - Patient chart preparation
 - Schedule appointments
 - Payment collection

- Qualifications**
- High school diploma or GED
 - Proven exp as a receptionist in a healthcare setting
 - Good interpersonal communication skills
 - enthusiastic attitude detail oriented & able to multi task
 - Computer knowledge & keyboard exp necessary

Interested candidates should submit their resume by April 15th to Michigan Heart PC C/O Dawn Wells 14555 Levan Rd Ste 203 Livonia MI 48154

MEDICAL RECEPTIONIST

Full time/part time front office person for busy exciting family practice in Livonia Medical experience preferred and strong phone skills required for this rewarding position Hours Mon and Tues 8:30am-6:00pm Wed and Thurs 9:00am-8:00pm Fri 9:00am-4:00pm Sat (approx one per month) 8:00am noon Call (734) 427 3504

Help Wanted-Medical 5060

MEDICAL ASSISTANT

Experience needed for internal medicine practice Fax 313 831 7002

MEDICAL ASSISTANT

Part time Will train mature individual 22 hours Call Tues or Wed 248 478 6870

MEDICAL ASSISTANT

Part/full time Walk in clinic in Westland Exp preferred 734 287 3733

MEDICAL ASSISTANT

Part time Livonia ENT office Knowledge of insurance & some exp required Fax resume to 734 261 8085

MEDICAL ASSISTANT INSTRUCTOR

Career school in Ypsilanti Arbor area has great part time teaching position Subjects include clinical procedures theory A&P 2/3 mornings a week \$72.80/session Must have appropriate education and 3 years office exp Call 734-434-7320 or fax resume 734-434-8579

Medical Assistant/Receptionist

Must have at least 2 yrs recent exp in a primary care setting & be a responsible hard worker Full or part time 734 323 0395

MEDICAL BILLER

F/T & P/T for a billing co Exp required Knowledge of MBS a plus Call 248 427 0632

MEDICAL RECEPTIONIST/ASSISTANT

Needed fax resume to 734 697 0374

MEDIOLOGE OF PLYMOUTH

We have positions available for RN/LPN Dayshift Contingent GNA Full time Midsights Please contact Joanne at (734) 453 3983

Pre-Authorization Representative

needed for Michigan Spine Care Center in Auburn Hills Requires a high school diploma experience in insurance authorization and basic computer skills To apply send resume to GAHS/HR 3955 Beecher Rd Flint MI 48532 or fax to (810) 762 5925

GENESYS

Intensive Coding

Program Service Assistant (Activities Department)

Assistant for busy Activities Department in Assisted Living facility with Alzheimer's and Dementia residents Previous relevant experience is a plus Mail or fax resume to Arden Courts 24005 W 13 Mile Road Bingham Farms MI 48025 Fax 248 644 0700 No phone calls please

RECEPTIONIST OPTHALMIC TECH & OPTHALMIC BILLER

For Southfield & Novi area Experience preferred Mail resume to Office Manager 767 E Walled Lake Dr Walled Lake MI 48390

RN CASE MANAGER

Day shift Large Southfield area physician organization seeks full time RN for Utilization Management/com case management for PPO plans Individual must have at least 3 yrs UR/Managed Care & 5 yrs clinical exp Current MI RN license required CCM preferred Fax resume to 248 593 0200

RN's & LPN's - 3-11pm Shift CNA's - Part time weekends

The Manor of Farmington Hills focuses on catching staff doing things right! We currently have an opening for RN's LPN's CNA's Long term care experience required

If you are a team player committed to excellence contact Chris Hamstra DON at 248 476 8300

Help Wanted-Medical 5060

RN/MEDICAL ASSISTANT EXP 'D

for OB/GYN practice Bloomfield Twp Fax resume 248 642 1443

THERAPISTS PTs/OTs/PTAs

needed for outpatient rehab clinics in area senior communities Full & part time Northville/Westland Southfield Ann Arbor/Ypsilanti & Adrian Fax resume to 588 288 7990 attn Karl

CERTIFIED X RAY TECH/ MAMMO TECH MEDICAL ASSISTANT MEDICAL BILLER

Northville private clinic Competitive wage & benefits Fax resume 248 349 4545 Email vssnsummers2091@hotmail.com

Help Wanted-Food/Beverage 5080

COOK

Exp d & dependable only apply Premium wages & benefits Apply in person Mon Fri 2-4pm at The Original Pancake House 33703 Woodward Birmingham

Accounting Applications NIGHT BARTENDER WAIT STAFF FOOD RUNNER PANTRY/GARDE MANGER LINE COOK

Full Benefit Package incl 401k

220 Restaurant



THE OBSERVER & ECCENTRIC PRESENTS

Personal Scene

Place your FREE print ad, call 1-800-487-2038 24 hours/7 days a week

NOW THERE ARE 3 GREAT WAYS TO RESPOND TO THESE ADS

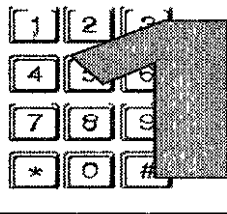

1-900-226-9950
\$2 19 PER MINUTE
2 19 PER CALL CONNECT FEE
18 years or older,
charges will appear on your
monthly telephone bill

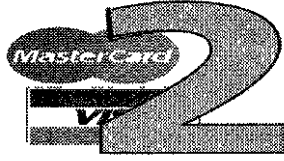

1-866-899-5644
\$2 49 PER MINUTE
using your credit card
you pay as you go, charges
will appear on your
credit card statement

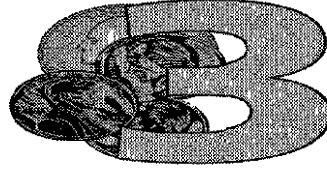

1-800-487-2038
use your credit card to
purchase tokens for as
little as \$ 34 per token or
to respond FREE to ads



Call 1-900-226-9950
\$2 19 per minute,
\$2 19 per call connect fee

GOOD NATURED
SWF 55 61 med um build col
lege graduate non smoker
Enjoys working out theater
movies walking and more
Seeking a kind quiet SWM 55+
who is well groomed profes-
sional for friendship first
Ad# 642061

LETS TALK
Outgoing and friendly SWF 19
5 4 brown hair blue eyes smok-
er Enjoys animals crafts the out-
doors and loves roller coasters
Looking for an honest and up-
front SWM 40 51 with similar
interests who has a get up and go
attitude Ad# 539760

TOUCH OF CLASS
Attractive tr m fun N/D N/S
SWF 72 from Bloomed ed
Looking forward to a companion-
ship with a SWM 72 75 who is a
real gentleman Ad# 653117

YOU WILL LIKE ME
SWF 66 55 blonde medium
build fun loving art Seeking
SWM 30 plus who wants to do
things is talkative humorous and
loves to cuddle if he estees call no
smokers Ad# 657267

LIFELONG PARTNER
Understanding SWF 51 a little
overweight but very attractve
Wishes to meet a rugged hard
working SWM 40 55 for
romance and closeness
Ad# 663268

SMILE WITH ME
SBF 24 Seeking an intelligent
honest and trustworthy SM 24
35 who is financially independent
Ad# 663105

BROWN EYED GAL
I'm a SWF 48 54 a medical
professionist seeking a church
going N/S good humored SWM
45 52 w/n no children at home
who loves laughter the theater
people and trying new things
Ad# 663974

BE MY BEST FRIEND
Very kind and caring SWF 46
5 4 med um build blue eyed
blonde Enjoys I ave r/cas nos
fish ng archery and antiques
Seeks an intellectual SWM 46
60 to fun times Ad# 532617

PATIENTLY WAITING FOR YOU
SWF 60 Auburn hair green eyes
professionist Enjoys travel week-
end get a ways camping cul-
ding and more Seeking a SWM
57 70 who is ovng humorous
N/S N/D fun and affectionate
Ad# 405309

BEAUTIFUL INSIDE & OUT
SWF 57 54 red curly hair
brown eyes Enjoys moving the
after boating swimming cooking
and time with family Seeking a
SWM 55 70 who is ambitious
spiritual successful and fun
Ad# 473611

ARE YOU THE ONE?
SWF 33 54 very active a pro-
fessional and hoping to meet an
intell gent professional SWM 32
42 in Michigan for a possible
realtorship Ad# 660543

ANXIOUSLY WAITING
SWF 60 52 brown hair med
um build Wants to meet a SWM
55 70 who is tall medium build
likes to go places s affect onate
and seeking a commitment
Ad# 660547

WHAT MORE DO YOU NEED?
SWF 45 54 129 lbs with blonde
hair and blue eyes Enjoys
reading camping motorcycles
and k/cubing Seeking a SWM
35 50 who is fun loving and
caring Ad# 663750

A LITTLE SPICE
Retired SWF 62 enjoys dning
out dancing travel ng o staying
home for a quiet evening She's
looking for a SWM 58 64 to put
some fun and excitement back into
her life Ad# 663750

MOONLIT WALKS
Interested? Romantic? SWF 59
5 4 135 lbs brownish hair
Enjoys walks under the moonlight
Looking for a car ng romantic
SWM under 65 Ad# 664007

FOLLOW YOUR HEART
SWF 41 56 148 lbs with one
child Looking for a tall profes-
sional SWM 40 or older who
enjoys the outdoors sports fam-
ily and children Ad# 664796

LET'S BEGIN AS FRIENDS
SBF 22 college student one
daughter Looking for an honest
caring understanding commu-
nitive SM 19 29 Ad# 664474

BE PART OF MY TOMORROW
Very average looking SWF 71
with blonde hair and blue eyes is
looking for a SWM 68 74 to
share companionship for dning
out datng and so forth
Ad# 663597

HOPES & DREAMS
SWF 25 41 150 lbs with one
child Enjoys traveling Looking for
a nice SM race and age unimpor-
tant who is educated employed
and accepts the fact have a chld
Ad# 663597

THE MARRIVING KIND
SWF 55 54 125 lbs with red
hair and green eyes Enjoys danc-
ing walking and sports Looking
for a marriage minded educated
SWM 55-65 with a good sense of
humor who likes having fun
Ad# 662734

SEEKING NICE GENT
SBF 51 55 good cook Seeking
a courteous SBM 45 59 5 5+ for
friendship first and then see what
happens Ad# 662187

ARE WE COMPATIBLE?
WWF 56 56 123 lbs long hair
stays in shape Enjoys gourmet
cooking & traveling Seeks a SWM
55 58 years old Ad# 660575

I LL BE WAITING
Calm laid back SWF 62 52 110
lbs blonde hair blue eyes Loves
family activities cooking croch-
et cultural events and more
Seeks a kind quiet SWM 55+ who
cares about other people and
loves an mals Ad# 567481

DINNER & A MOVIE
Responsible SWF 51 years old
seeks non smoking non drinkng
SWM 50 65 who's ookng for
companionship Ad# 660427

SOUTHERN BELLE
Down to earth SWF 29 55 120
bs a pretty blonde Loves danc-
ng dning out and time at home
with a spec a someone Wants to
be spoiled by a SWM 40-58 with
no baggage Ad# 660306

THE KEY TO HER HEART
SWF 58 enjoys boating reading
movies and dning out She's look-
ng for a N/S SWM 59 or taller
social drinker ok with sex and pep-
per hair If this sounds like you
give her a call Ad# 659790

CALL & CHAT WITH ME
SWF 53 53 weight proport on-
ate Enjoys gardening movies fine
dning good conversation plus
more Hopes to meet a SWM 50
60 Ad# 659405

SEKS FRIENDSHIP
SWF 50 57 weight proport on-
ate retired Loves dancing time at
home and people Looking for a
SWM 47 60 Ad# 659697

ONE IN A MILLION
Professional educated DWf 43
with one child Enjoys movies d-
ng out swimming bike dng and
more Looking for an honest
sncere SWM 35 52 who's not
into games knows what they want
and enjoys the outdoors
Ad# 656858

HUSBAND WANTED
SWF 38 attractive blonde likes to
cuddle fine dning out fine
dning caring romantic pass on
ate N/S not outdoor type Seeks
SWM 35 55 6+ attractive sta-
ble serious relationship passion
for spendng quality time no
sports/ba type Ad# 656162

ROMANCE
s just a ound the corner I am
52 with da k eyes and hair 63
Looking to meet a tall gentleman
59 70 who likes dancing cards
travel and wants a long term rela-
tionship Ad# 403303

ALL OUR TOMORROWS
DWf 43 enjoys spending time
with her children reading cooking
and the beach Looking for a good
hearted SWM 40 50 who's fun
likes to have a good time and likes
children Ad# 656043

END MY SEARCH!
I'm an honest dependable SW
Mom 25 55 105 lbs smoker
with brown hair & hazel eyes
Looking for a long term relation-
ship with a tall SWM 55 60
who enjoys summer and winter
activities and has time for me
Ad# 655797

WHY NOT CALL?
SWF Mom 24 56 120 lbs Enjoys
shopping movies etc Seeks a
SBM 25 30 who enjoys going to
church and tryng new things
Ad# 655731

CONTACT ME
Brown eyed SBF 30 years old
mother of two She enjoys movies
bowling and is seeking a ce
SBM 21 40 who loves kids
Ad# 654399

CHAT
SBF 26 57 115 lbs with a great
sense of humor and no children
Looking for a SM 22 32 who s
good looking ng Ad# 654219

RESPECTING EACH OTHER
Full figured educated SBF 37
5 11 no children N/S N/D
Enjoys watchng sports on TV
reading bowling and the simple
things in life Looking for an hon-
est mature SBM 37 50 who's
employed and has s own trans-
portation Ad# 644676

JUST THE GAL FOR YOU!
Attractive SWF 61 56 brown
hair/eyes Enjoys theater travel
dning out and family Looking for
an honest good humored SWM
55-65 N/S Ad# 653249

ARE YOU MY SOULMATE?
SWF 44 N/S social drinker 56
140 lbs blue eyed blonde
Interests are movies bowling and
canning She's looking for a seri-
ous financially secure N/S SM
35 60 whose children are grown
and who appreciates women
Ad# 641647

FORMER MODEL
SWF 49 56 with intelligence
creativity and a passion for music
and dancing Seeking a man 39-
49 to share these interests and
more for a possible LTR
Ad# 536167

JUST MOVED BACK
Adorable SWF 33 55 130 lbs
brown hair and light green eyes
Seeking a SWM 35 47 who is
affectionate and humorous
Ad# 644179

ENJOYS LIFE
SWF 52 54 red hair brown eyes
Likes dning out traveling
mov es & dng Harley's in the sum-
mer and more Seeking a SWM
45 59 who enjoys life
Ad# 643675

SEKS UNDERSTANDING MAN
Caring dependable SWF young
looking 38 looking for a flexible
SWM 30 50 Ad# 643379

FRIENDS TO START
Very busy SWF 38 enjoys
movies traveling theater comput-
ers and quiet times Looking for a
sncere educated employed
SWM 30 50 who can be flexible
due to my busy schedule and is
interested in friendship to start
maybe more later Ad# 643444

HEART OF A POET
SWF 40 55 w th brown eyes
height/weight proportionate
Enjoys fishing camping writing
photography and more Looking
for a SM under 50 who has sim-
ilar interests Ad# 643372

THE COFFEE IS ON
SWF 57 natural blonde blue eyes
with brown children Looking for a
prompt N/S N/D mature SWM
57 80 who would like to get
together and talk over a cup of cof-
fee Ad# 642834

SEARCHING
SWF 44 who loves the loud p pes
Harley's also likes The Red
Wing's Seeking SWM 45 55
Ad# 501033

LET'S LIVE
51 W/ independent I like movies
travel dning out dancing
Looking for SWM 50 60 with
some interests No couch potatoes
and if interested give me a call
Thank You Ad# 616570

WHAT'S YOUR SIGN?
Witty faithful outgoing SWF 41
blue eyed blonde 5 2 Loves
roller coasters computers cards
racing camp ng and fishing
Looking for a good humored
open minded passionate SM 35
55 who enjoys life Ad# 536207

READY TO SETTLE DOWN
SWF 47 52 attractive blonde
hazel eyes with a beautiful smile
Seeking a honest and caring SWM
40 52 who enjoys spending time
with that special someone
Ad# 641159

LETS SHARE LIFE TOGETHER
SBF weight proport onate 47
enjoys travel weekend getaways
campng movies plays dning
in/out romantic days in search of
a SCM 45 65 family oriented
with similar interests Ad# 640890

SEEKING CHURCH GOING MAN
SWF 42 i enjoys going to church
looking for a fun respecta-
ble clean cut, SB gent man 18 30
N/S N/D who is serious about a
committed relat onship
Ad# 640709

LOOKING TO BE SPOILED
SBF 27 mother of 3 boys Seeking
SWM over 30 for a poss b e rela-
tionship Ad# 640217

TRY IT OUT
SWF 46 beautiful blonde who is
romantic and sophisticated
Enjoys the bookstore entertainng
and cooking Seeks a special
SWM to make her house a home
He should be intelligent financ-
ally/motionally secure handsome
generous & marriage minded
Ad# 640050

SIMPLE LIFE
SWF 57 54 110 lbs brown hair
and green eyes Enjoys sports
beach go cooking dning
Seeking SWM who s outgoing
friendly loyal and good hearted
Let's have fun and good times
together Ad# 640037

LOVABLE SWEETIE
SWF 42 i enjoy family cook-
ing and movies Seeking a SWM
who is honest sincere You must
enjoy life and good conversa-
tions! Ad# 639222

A DIFFERENT KIND OF AD
Petite WF 61 sort of cute smart
spiritual & spirited I am living with
some health chal enges and am
seeking a happy honest senior
male who s tired of facing his
challenges alone & needs some
tender loving care Great cook
writer philosopher Ad# 572333

COMPLETE HONESTY A MUST
m a sncere SBF 21 with one
son I'm searching for an ene-
getic fun honest; SBM who
beaves that honesty is the key to
a strong relationship Ad# 636745

LIKE GOOD SURPRISES?
SBF 28 51 111" bly blond N/S
N/D Enjoys bowling movies cas-
nos travel and time with friends
Looking for a honest person a
SM Ad# 636602

LOOKING FOR A FRIEND
SBF 31 57 145 lbs light com-
plexion Looking for a sweet spon-
taneous level headed good look-
ng SBM 25 35 Ad# 636499

LOOKING FOR HONESTY
SWF 58 54 w th green eyes
Enjoys the water and trying any-
thing once in search of a tall
SWM 55 65 who s honest w th
a great sense of humor and s mi-
lar interests Ad# 636111

LOOKING FOR FUN
I'm ready for fun & laughter! SBF
46 6 a smoker social drinker I
enjoy watching sports and travel-
ng I'm searching for a SBM 55
70 who shares my interests
Ad# 503750

GOOD NATURED
SBF 47 5 3" dark brown hair
outgoing sincere and fun loving
Enjoys shopping travel dning
concerts the outdoors pnces and
more Seeking a SBM 40 60 who
is sincere outgoing ng loving
family oriented and is a kid at
heart Ad# 442747

For even more ads visit
<http://www.observersingles.com>
View a photo of this person online
Respond to this ad for FREE by calling 1-800-487-2038
View an expanded profile for this person online

LOVE TO GIVE
SWF 27 59 145 lbs blonde
hair green eyes She's seeking a
man who loves child en has a
sense of humor is honest and
enjoys quiet times at home
Ad# 633192

ARE WE ALIKE?
SWF 50 with above ave age
looks good commun cato amus-
ng loving sou mate Seeking
DWM 46 60 cean cut gentleman
looking for serious relat onship
Ad# 482668

BE MY VALENTINE
SWF 80 with blonde hair and N/S
Looking for a N/S SWM 80 77
who s loving positive caring
compassionate emotionally finan-
cially secure and who loves life to
the fullest Ad# 612080

ONE OF A KIND
SWF 48 attractive intelligent lov-
ing and dedicated Seek ng a SWM
45+ a N/S who is sincere intelli-
gent humorous and honest for a
long term devoted relationship
Ad# 448774

KIND & LOVING HEART
Professona attractive SBF 46
5 5 full figured hazel eyes
Looking for a professona N/S
SM 40 52 who s trust worthy out-
going and energetic Ad# 621077

HONEST & CARING
SWF 42 5 blonde hair blue eyes
friendly and bubbly Enjoys ong
drives walks movies coddng
and much more Seeking an hon-
est and caring SM 35 52
Ad# 619145

KISSES FROM ME
Athletic outgoing energetic and
happy SWM 43 59 who enjoys
sports working out animals and
more Seeking an honest caring
warm and sens tive SF 35 50 who
can carry on an intell gent conver-
sation Ad# 468055

HANDSOME & WITTY
Hi I'm a SWM 55 who kes
sports and s desc ibed as intelli-
gent and outgoing I would like to
meet a SWF 30-45 who is not
materialistic and who has a nice
personality Ad# 668093

LET ME CARE FOR YOU
Witty and funny SBF 52 52
Hobbies and interests include
roller skating bike riding walks
and other activities Seeking a
Ch lsiem SBM 18-60 to get to
know better Ad# 581578

A LONG KNIGHT
Attractive SWM 51 6 180 lbs
with brown hair brown eyes and a
wde var ety of interests Search ng
for a petite to average bu lf SF 38
54 race unimportant who s
down to earth sncere and honest
Ad# 419021

ARE YOU READY?
Do you have a passport? Do you
have a sw/mult? Do you dance
shoes? I'm 55+ tall slim active
ready for a friendship compan-
on s/p romance with a SWF 48 60
who is my equal Phone rap res-
only please! Ad# 612394

STILL LOVE THE BEACH BOYS
I'm a sandy and athletic SWM
51 1 38 but ook and feel much
younger Who e s my surfer gr?
I you are slende and slow mov-
ng I will sweep you off your feet
and s/ng to you every day and
night Ad# 660637

A REAL GENTLEMAN
Retired educated SWM 60 59
160 lbs with blue eyes & dark
hair Enjoys bowling long walks
dning out dancing and omnic
evenngs Lookng for a SWF 45
60 who s active for a long term
pleasant relationship Oakland
county Ad# 663655

50-55 WHITE MALE
SWM 39 55 170 lbs clean cut
Likes long drives and gardening
Seeks a down to earth neat ady
we ght p oport onate age open
Genesse County Phone responses
only Ad# 657006

SERIOUS REPLIES ONLY!
SWM 30 51 180 lbs black
hair green eyes Seeking a SF
under 45 who is adventurous and
down to earth Ad# 680479

HOT N NOW
SWM 39 65 who likes concerts
dng photography rock and roll
sportng events and hanging out
with friends Would like to meet a
slim to medium bu lf SWF 21 39
N/S No baggage or druggs
Ad# 559315

BREAK THE ICE
SWM 41 64 w th brown hair
blue eyes and 2 chldren Interests
ncude boating fishing camp ng
anything outdoors Looking for a
SF 28 40 to spend time with and
share special moments w th
Ad# 670674

HELLO SUNSHINE
Very attractive SWM 34 6 185
lbs w th green eyes and brown
hair Looking for a SF race and age
unimportant who s intelligent and
knows a little about the world
Ad# 663154

DEDICATED TO YOU
Easygoing SW Dad 44 57 180
lbs brown hair and blue eyes He
enjoys the outdoors and is seek ng
a trustworthy honest SWF 38-44
who likes chldren is smol onal-
ly stable and Church oriented
Ad# 519634

FAITHFUL & LOVAL
SWM 44 61 175 lbs with
brown grayng hair Looking for a
SWF under 48 for quiet romantic
times together Ad# 668504

EDUCATED PROFESSIONAL
SWM 45 58 ft ight brown hair
blue eyes Looking for a passion-
ate compassionate professional
SWF 28 45 Oak and o Wayne
County Ad# 449863

LOOK INTO MY EYES
SBM 31 61 190 lbs with black
hair green eyes and children not
living at home Enjoys dancng
we'ng sports and bowling
Looking for a SBF 18-38 with a
medium complexion green eyes
and no children Ad# 685727

THE SEARCH IS OVER
SWM 48 6 235 lbs with blonde
hair smoker N/D Enjoys to Las
Vegas and bike riding Looking for
a SWF 35-48 who s honest easy
going height to weight proport on-
ate and easy on the eyes
Ad# 685892

ATTENTION LADIES
SWM 19 65 180 lbs with and
athletic bu lf black hair and blue
eyes Looking for a SF to have fun
with someone who s easy to talk
to Let's talk and see where it leads
us Ad# 685663

EASY TO TALK TO!
Single who is 45 62 209
lbs muscular athletic brown hair
blue eyes cean cut degree bear-
mered nd depends outng
personality Enjoys roller bladng
workng out etc Seeks a friendly
single female Wayne County
Ad# 404068

WAITING FOR YOU
Tall SWM 29 who is looking for a
long term relationship with a SWF
23 33 who is pretty fun loving
and enjoys life Ad# 571725

NICE & FUNNY
SBF 37 51 125 lbs enjoys
jazz walkng coddng and more
Looking for a SF 25 36 who is
low down to earth sweet and
has respect for herself
Ad# 565294

GOOD MORNING SUNSHINE
SWM 59 62 200 lbs no chil-
dren at home Enjoys reading &
dning out cookng and
much more Looking to meet a
SWF 48 61 who is lookng for a
long term serious relationship
Ad# 669635

GOOD GUY
SBM 32 51 150 lbs who
cate s to that special woman s
needs Seeking a SBF 18 40
Ad# 669208

Face It
Hearing is believing
Chat NOW with singles...
one-to-one, securely & anonymously!
Place your FREE ad
1-800-487-2038
Press 6 at the main menu
or online at
<http://www.observersingles.com>
Face forward with our personals

CARING & HONEST
SWF 44 N/S N/D who enjoys
campng walking the outdoors
fish ng chldren and experie-
ng new things If you are a N/S
N/D SWM 38-52 and are inter-
ested call me and we'll talk!
Ad# 417121

COULD IT BE YOU?
WWF 59 grey hair pleasant
loving and kind hearted Enjoys
walking movies music the out-
doors and more Seeking a SM
who for a friendship first
Ad# 633551

SHARE HER DREAMS
Fun loving SBF 40 57 175 lbs
social drinker smoker with chld-
ren Searching for a smart SBM
35 50 who lves alone and would
like to get to know each other
Ad# 633659

GET TO KNOW ME
DWF 30 smoker with chldren
likes to go out and have fun tryng
dferent things and the simple
things in life Lookng for a sincere
honest SWM 25 35 who lves
on lran and quiet times at home
Ad# 633096

WHAT THE FUTURE HOLDS
DWF 30 55 blonde hair blue
eyes enjoys mov es dancng d-
n g out and spending time with
chldren Looking for an honest
sncere SWM 25 35 to have
some fun with fr iends p-
ortation Ad# 633034

BLUE EYES
SWF 58 petite blue eyes profes-
sional Looking for a SWM 50 64
who is fun loving enjoys traveling
dancing and is looking for a
woman to share the good I most!
Ad# 623698

WORDS CAN DESCRIBE
She is 36 milk chocolate com-
plexed petite curvaceous and
sweet as can be Are you a tal-
l chck SBM 28 45 who shares her
passion for jazz the theater and
ready for her sparking personal-
ity? You know what to do leave
a message! Ad# 629394

GOOD MORALS
This SWF 44 works n health care
and has long brown hair blue
eyes and s open to new interests
Looking for a SWM with good
morals who works afternoons 39
61 no children Ad# 623261

LOOKING FOR LOVE
SWF 33 51 with reddish/brown
hair & dark brown eyes Interests
include bowling dancing cooking
movies and much more Searching
for a SWM age not important who
has s milar interests Ad# 418650

FUN LIFE
SWM 68 61 210 lbs brown
hair and eyes active easygoing
and fun to be around Seeking an
affectionate SF age unimportant
who s fun to be with! Ad# 683232

Jobs and Careers

All Ads Run Online
FREE!
A Value Of Up To \$87.00
www.hometownlife.com

Market Place

All Ads Run Online
FREE!
A Value Of Up To \$87.00
www.hometownlife.com

Earn extra \$\$ advertise with O & E
1-800-579-SELL

Help Wanted-Sales (5120)

Real Estate Agents
A CAREER IN REAL ESTATE!

ALL REAL ESTATE COMPANIES ARE NOT THE SAME

If you are serious about entering the business and profession of Real Estate Sales you owe it to yourself to investigate why we are #1 in the market place and best suited to insure your success

*#1 Rated Franchise System
*Continuous Individualized Training
*100% Commission Plan
*Group Health Coverage
*Free Fr License
*Latest Technical Computer Programs Enable You To Have The Competitive Advantage
*Unsurpassed Local and National Advertising Exposure

DISCOVER THE DIFFERENCE
Call Jim Stevens or Alissa Nead

COLDWELL BANKER

PREFERRED REALTORS (734)459-6000

Real Estate Agent
A CAREER IN REAL ESTATE! LOOK NO FURTHER

If you desire to work in western Wayne county be with number 1 see our other ad for details
Call Denise Setser 734 392 6000

COLDWELL BANKER

PREFERRED REALTORS

Real Estate
CHANGE YOUR LIFE!!!!

Start a new career
CALL SANDRA @ REAL ESTATE ONE
248 208 2917

COLDWELL BANKER

PREFERRED REALTORS

Real Estate
Professional Sales

Metro Detroit's Premier Real Estate Office is looking for a select number of team members Our 40% growth has created a need for more Realtors in our Plymouth and Canton locations Will train to be top producers Full time support Technology at its best Call Claire Williams

REMERICA

HOMETOWN ONE 734 420 3400

Real Estate Sales
Are You Ready For A Change?

Join us Wednesday March 31 at 7pm for a free career seminar on what it takes to be successful in real estate sales
Call CENTURY 21 Hartford at 248 478 6000 to register

Real Estate
Century 21 Towne Pride is seeking full time agents Exp not necessary We will provide training and a complete support staff For interview call Steve 734 326 2600

REAL ESTATE SALES ASSISTANT PART TIME

Busy Real Estate Team desires personable individual to coordinate listings & sales Must be computer proficient have exc communication skills and warm friendly people skills Somewhat flexible hrs Fax resume to Nancy 734 454 4517

Help Wanted-Sales (5120)

REAL ESTATE SALES THINKING OF CHANGING CAREERS? LOOKING FOR INDEPENDENCE AND CONTROL OVER YOUR FINANCIAL FUTURE?

Real Estate just may be your answer Comprehensive live training and support provided so you can reach your goals
734 455 6000
Weir Manuel Snyder & Ranke
500 S Main St Plymouth

SALES

Home Improvement Leads furnished full & part time ok No weekend leads Get paid upfront Call Wayne at Good Housekeeping 248 557 3200

SALES PROFESSIONAL (Building Products)

Major building supply wholesaler is looking for an experienced energetic sales professional to call on new and existing accounts in the Ann Arbor to Novi areas This is a career opportunity Knowledge of building supply industry is key to your success No overnight travel Full fringe benefits package including company car Send resume including salary history to M B S 3835 Morgan Rd Ypsilanti MI 48197 ATTN Branch Manager EOE

SALES MANAGER LeafGuard

The leader in leaf debris gutter protection for your home seeks Sales Manager LeafGuard Midwest is an employee owned business and is one of the largest LeafGuard dealers in the country If you have a history of managing sales for a large home improvement company with a sales force of ten or more you might want to consider us Degree required with a strong emphasis in national known sales training If you have been trained in the art of selling and want to work for a company that is a leader and not a follower please fax or email your resume to us Consideration will only be given to applicants with a strong history of sales management in home improvement Fax Number is 248 437 5249
Email LeafGuard@bignet.net
LeafGuard Midwest
29244 Lyon Oaks Drive
Wixom MI 48393
Call (248) 437 3700

SALES PERSON

For carpet store Must be able to do estimating blue prints & scheduling Located in Novi Fax resume 248 735 8873

SALES PERSON

Short term for outside sales Excellent income Westland area Call Dan 734 422 0220

Sales Professional LeafGuard

The leader in leaf debris gutter protection for your home wants Professional for in home sales If you are a top producer for your company and want to work for one of the largest LeafGuard dealers in the country to earn top dollar you might want to consider us LeafGuard Midwest is an employee owned company that can provide you with an unfair sales advantage against competition If you have been schooled in the art of selling and want to work for a company that is a leader and not a follower please fax or email your resume to us Average sales people should not apply we are only looking for the best who has a six figure earning history in home sales Fax Number is 248 437 5249
Email LeafGuard@bignet.net
LeafGuard Midwest
29244 Lyon Oaks Drive
Wixom MI 48393
Call (248) 437 3700

SALES REPS

Seeking independent sales reps for commercial industrial and residential sales Experience preferred Excellent income potential Please submit resume to (248) 919 1155

Sales/Telemarketing LeafGuard

The leader in leaf debris gutter protection for your home wants professionals for inside sales LeafGuard Midwest is an employee owned company that can provide you with an unfair sales advantage against competition We seek top performers Salary based plus commission Fax Number is 248 437 5249
Email LeafGuard@bignet.net
LeafGuard Midwest
29244 Lyon Oaks Drive
Wixom MI 48393
Call (248) 437 3700

SALESPERSON for growing carpet cleaning company Must be aggressive with proven sales track record
Call 248 632 2406

Help Wanted-Sales (5120)

SYSTEMS INTEGRATION SALES

Dearborn based systems integrator firm is seeking sales managers The ideal candidates will be versed in computer telecommunication on audio visual and surveillance technology Salary based on exp industry knowledge and established customer base Please send resume to Human resource 15011 Michigan Ave Dearborn MI 48126 or email hr@tisc.com

WOMEN'S SHOE SALES

Part time for area's finest salon Good salary liberal employee discount plus commission No Sunday's sometimes 1 evening till 8 Flexible hours a must Better shoe experience a plus Call Arlene 248 855 8855
ROZ & SHERM
Maple & Telegraph

Help Wanted-Part-Time (5200)

AVON NEEDS

Representatives Now! Call 734 422 7214

GENERAL HELP for unique sign company Approx 20 hrs/wk Mon Fri Call David 734 427 4141

JEWELRY SALESPERSON

For Plymouth AGS store (734) 455 3030

RECEPTIONIST

Veterinary hospital in Livonia 18 or over Computer typing skills needed 3 days/wk 3pm-9pm 2 Saturdays/mo 8am-5pm (248) 476 0750

VETERINARY TECHNICIAN

Opening in fully equipped animal hospital in Livonia MI Fri 5pm-9pm Sat 8am-5pm Over 18 Experience preferred (248) 476 0570

Help Wanted-Domestic (5240)

HEALTHCARE WORKER

Wanted for Livonia woman part time 20-30 hrs per week Good hourly pay Must have car Call between 7pm & 9pm 248 348-4459

HOUSEKEEPER needed in Bloomfield Hills home Good salary Fax call back information to 248 258 1605

Job Opportunities (5310)

HIRING 2004! U.S. POSTAL JOBS! UP TO \$1 047.71 WEEKLY FREE CALL FOR INTERVIEW AND REGISTRATION INFORMATION SIGN ON BONUS 1ST 100 CALLERS SELECT AREAS 1 800 892 5549 ext 91 7 days

HIRING 2004! U.S. POSTAL JOBS! UP TO \$5 481.07+ year FREE call for INTERVIEW & registration information Paid training + benefits sign on bonus Select areas 1 800 892 5144 ext 97 7 days

"MOVIE EXTRAS" \$200 \$600/day All looks types & ages No experience required TV music videos film commercials Work with the best 1 800 280 3949 ext 3244

"NOW HIRING" For 2004 Postal jobs \$16 20 \$39 00/hr Paid training Full benefits No exp necessary Green Card OK Call 1 866 399 5718 ext 3500

ANNOUNCEMENT NOW HIRING For 2004 Postal Jobs \$16 20 \$39 00/hr Full Federal Benefits Paid Training No experience required Green Card OK Call 1 866 895 3696 ext 2400

EARN \$1 000 \$3 500 WEEKLY Answering Surveys Online \$25.00 per survey! FREE registration! Guaranteed pay checks! Mystery shoppers needed! \$57.00/hr shop ping! FREE Government grants! \$12 000 \$500 000! Everyone qualified! www.RealCashPrograms.com

GOVERNMENT JOBS Earn \$12 845.00 an hour! Full benefits paid training on Homeland Security Law enforcement Wildlife Clerical Administrative & more 1 800 320 9353 ext 2200

GOVERNMENT JOBS! WILDLIFE/POSTAL \$13 51 to \$58 00 per hour Full benefits Paid training Call for application and exam information No experience necessary Toll free 1 866 269 6090 ext 200

HIRING FOR 2004 POSTAL POSITIONS \$15 00 \$45 00+/HR *Federal hire with full benefits No experience necessary *Paid training and vacations *Green Card OK Call 1 866 317 0556 ext 4001

Hiring for 2004 Postal Positions \$600 \$1520/WEEKLY plus full federal benefits Entry professional level No experience necessary Paid training/vacations Green Card OK 1 866 317-0558 ext 805

Students (5320)

College Student Seeks Mon Fri summer Nanny position Extensive child care exp w/children of all ages Exc ref Lauren 248 730 6378

Position Wanted (5340)

Caregiver Aide available For elderly or medically disabled Car no honest transportation Good ref (248) 968 3481

Childcare Services-Licensed (5360)

AFFORDABLE DAYCARE in S Redford home Lots of TLC Meals/snacks provided 6 yrs exp 313 977 1792

Plymouth 24hrs 7days for all your childcare needs Check out www.kellycare.com (734) 459 9566

Childcare Needed (5380)

BABYSITTER NEEDED in my Livonia home for Friday or Saturday night Will hire or trade Ref (734) 462 2466

NANNY

needed for 2 year old boy in W Bloomfield / Farmington H is home M Th 8 4 p m Must be dog friendly Please send qualifications to carpenter95@comcast.net References required

NANNY

full time live out for good natured 4 month old Non smoker own car resume/ref erences W Bloomfield area (248) 877 1482

NANNY

Non smoking loving caring dependable person for newborn starting June 30-hrs/wk West Bloomfield (248) 819 6229

NANNY

Loving family w/2 girls 11 mos & 29 mos looking for full time nanny 40 45 hrs/wk (248) 723 4588

NANNY in search of a warm kind & honest person to take care of our gentle loving 3 yr old son in our Plymouth home 3 full days 2 half days Call Lisa at 734 453 7643

NANNY full time looking to be part of a wonderful family for 2 infants & 1 toddler in Huntington Woods Non smoking Exp necessary 248 851 2098 248 417 2715

WORKING AT HOME MOTHER

Searching for a reliable career to watch my two children 1 & 2 1/2 yrs old Mon & Thurs 4 hrs per day \$7 00/hr Ref & background check a must (734) 398 5404

Attorneys/Legal Counseling (5780)

BANKRUPTCY

House In Foreclosure? Garnishment? Repo Threat? Call Danton & Smyk for a FREE CONSULTATION and a FRESH START! Telephone & 12 Mile 248 351 9311

Business Opportunities (5740)

Are you making \$1 000 per week? All cash vending routes with prime locations available Now Under \$9 000 invest ment required Call Toll Free (24 7) 800 668 9569

AREA MILLIONAIRE Looking for 5 entrepreneurs who want to make serious money 1 800 999 8317
www.GenerateFortunes.com

DATA ENTRY Great pay Flexible hours! Computer required Free training MBN 1 800 382 4282 ext 463

EARN \$1 000 \$3 500 WEEKLY Taking simple surveys online! \$75.00 per survey! Free registration Guaranteed paychecks! Free Government grants! \$10 000 \$250 000 never repay! Everyone qualified! Incredible opportunities! www.FastCashAtHome.com

ENSURE BUSINESS SUCCESS Plan your business future Start up or expansion hire available Call 1 866 816 0155

Business Opportunities (5740)

FOOD CRITICS! No experience needed! Up to \$80 per assignment! Email address required 1 888 327 4842 Dept C 503

LOOKING to increase my small vending machine business Need small candy machines Vendor preferred (734) 414 9993

Luxury Conferences Are you driven by desire? Able to earn \$2 000 \$4 000 a week Complete company training proven business strategy Call for appt 888 523 5010

Own 5 10 ATM machines in prime high traffic locations Contiguous residual income \$10K minimum investment required 800 388 1785

P/T Hrs F/T pay Proven opportunity! Data entry Computer required Free sup port 1 800 382 4282 ext 80

PLYMOUTH Landscape & Maintenance Co Must sell Very profitable Equip & employees stay Deadline for offers & interviews Sat Mar 27 5pm 734 459 2991

WORK AT HOME

www.cotind.com 1 888 745 1731

Announcements (6000-6900)

Personals (6000)

Novena to St Jude May the sacred heart of Jesus be adored glorified loved and preserved throughout the world now and forever Sacred Heart of Jesus pray for us St Jude worker of miracles pray for us St Jude helper of the hopeless pray for us Say this prayer 9 times a day by the 9th day your prayer will be answered Publication must be promised AMK

Novena to St Jude May the sacred heart of Jesus be adored glorified loved and preserved throughout the world now and forever Sacred Heart of Jesus pray for us St Jude worker of miracles pray for us St Jude helper of the hopeless pray for us Say this prayer 9 times a day by the 9th day your prayer will be answered Publication must be promised AMK

INVENTORS PRODUCT IDEAS NEEDED Davison is looking for new or improved product ideas or inventions to prepare/present to corporations for licensing Free information package 1 800 544 3327

TARGET TO MILLION HOMES WITH YOUR AD Advertise your product or service to approximately 10 million households in North America's best suburbs by placing your classified ad in nearly 800 suburban newspapers just like this one Only \$95 (USD) for a 25 word ad One phone call one invoice one payment Ad copy subject to publisher approval Call The Suburban Classified Advertising Network at 888 486 2466

Happy Ads (6020)

ANCHORFABRICS.COM

Interior Design discussion group on the web

Announcements & Notices (6200)

DEARBORN WOMEN'S EXPO

Saturday March 27 2004 from 10am - 8pm at the Ford Community & Performing Arts Center located at 5801 Michigan Ave (Michigan Ave & Greenfield Road) Dearborn MI 48126 \$3 Admission * FREE PARKING * Door Prizes * Over 80 Exhibitors And Special Lectures & Presentations Of Interest For Women From Financial Planners Bridal & Prom Fashions Cooking Oakwood Health Services Home Decor Travel Florist and many more! JOIN JIM PAOLUCCI FROM MAGIC 105.1 RADIO from 12p-2p 105.1 & Prom Show at 2p Tel (313) 563 3046

GRAND OPENING MYSTIC MOMENTS IN HOME DAY CARE

WE TAKE PRIDE IN OUR CHILDREN PLEASE CALL NICOLE Tel 517 333 2162

JUNK CARS WANTED

FREE PICK UP W/TITLE 734 261 4850

Announcements & Notices (6200)

LAS VEGAS NITE Sat Mar 27 8pm midnight at the F'nish Center Our fun begins with Black Jack Maverick Draw roll your chances at the Crap table and come try our new game Let It Ride Cash prizes & free refreshments \$10/person 35200 W 8 Mile Rd Farmington Hills 48335 For more info 248 478 6939

Legal & Accepting (6220)

March 25 2004 STATE OF MICHIGAN PROBATE COURT COUNTY OF WAYNE

Notice to creditors filed 1999 609662 DE Estate of William John McIlrath Jr date of birth May 5 1928 Notice to creditors the decedent William John McIlrath Jr who lived at 9657 Norborne Redford Twp MI died March 7th 1999 Creditors of the decedent are notified that all claims against the estate will be forever barred unless presented to Marilyn McIlrath named personal representative 9657 Norborne Redford Twp MI 48239 or to both the probate court at 1305 Coleman A Young Municipal Center 2 Woodward Ave Detroit MI 48226 3447 and the named personal representative within 4 months after the date of publication of this notice Attorney Joseph Barkus Bar no P56988 202 N Saginaw St P O Box 266 St Charles MI 48655 (989) 865 8298

Cards Of Thanks (6300)

Novena to St Jude May the sacred heart of Jesus be adored glorified loved and preserved throughout the world now and forever Sacred Heart of Jesus pray for us St Jude worker of miracles pray for us St Jude helper of the hopeless pray for us Say this prayer 9 times a day by the 9th day your prayer will be answered Publication must be promised AMK

Novena to St Jude May the sacred heart of Jesus be adored glorified loved and preserved throughout the world now and forever Sacred Heart of Jesus pray for us St Jude worker of miracles pray for us St Jude helper of the hopeless pray for us Say this prayer 9 times a day by the 9th day your prayer will be answered Publication must be promised AMK

Novena to St Jude May the sacred heart of Jesus be adored glorified loved and preserved throughout the world now and forever Sacred Heart of Jesus pray for us St Jude worker of miracles pray for us St Jude helper of the hopeless pray for us Say this prayer 9 times a day by the 9th day your prayer will be answered Publication must be promised AMK

Novena to St Jude May the sacred heart of Jesus be adored glorified loved and preserved throughout the world now and forever Sacred Heart of Jesus pray for us St Jude worker of miracles pray for us St Jude helper of the hopeless pray for us Say this prayer 9 times a day by the 9th day your prayer will be answered Publication must be promised AMK

Novena to St Jude May the sacred heart of Jesus be adored glorified loved and preserved throughout the world now and forever Sacred Heart of Jesus pray for us St Jude worker of miracles pray for us St Jude helper of the hopeless pray for us Say this prayer 9 times a day by the 9th day your prayer will be answered Publication must be promised AMK

Novena to St Jude May the sacred heart of Jesus be adored glorified loved and preserved throughout the world now and forever Sacred Heart of Jesus pray for us St Jude worker of miracles pray for us St Jude helper of the hopeless pray for us Say this prayer 9 times a day by the 9th day your prayer will be answered Publication must be promised AMK

Novena to St Jude May the sacred heart of Jesus be adored glorified loved and preserved throughout the world now and forever Sacred Heart of Jesus pray for us St Jude worker of miracles pray for us St Jude helper of the hopeless pray for us Say this prayer 9 times a day by the 9th day your prayer will be answered Publication must be promised AMK

Novena to St Jude May the sacred heart of Jesus be adored glorified loved and preserved throughout the world now and forever Sacred Heart of Jesus pray for us St Jude worker of miracles pray for us St Jude helper of the hopeless pray for us Say this prayer 9 times a day by the 9th day your prayer will be answered Publication must be promised AMK

Novena to St Jude May the sacred heart of Jesus be adored glorified loved and preserved throughout the world now and forever Sacred Heart of Jesus pray for us St Jude worker of miracles pray for us St Jude helper of the hopeless pray for us Say this prayer 9 times a day by the 9th day your prayer will be answered Publication must be promised AMK

Novena to St Jude May the sacred heart of Jesus be adored glorified loved and preserved throughout the world now and forever Sacred Heart of Jesus pray for us St Jude worker of miracles pray for us St Jude helper of the hopeless pray for us Say this prayer 9 times a day by the 9th day your prayer will be answered Publication must be promised AMK

Novena to St Jude May the sacred heart of Jesus be adored glorified loved and preserved throughout the world now and forever Sacred Heart of Jesus pray for us St Jude worker of miracles pray for us St Jude helper of the hopeless pray for us Say this prayer 9 times a day by the 9th day your prayer will be answered Publication must be promised AMK

Novena to St Jude May the sacred heart of Jesus be adored glorified loved and preserved throughout the world now and forever Sacred Heart of Jesus pray for us St Jude worker of miracles pray for us St Jude helper of the hopeless pray for us Say this prayer 9 times a day by the 9th day your prayer will be answered Publication must be promised AMK

Novena to St Jude May the sacred heart of Jesus be adored glorified loved and preserved throughout the world now and forever Sacred Heart of Jesus pray for us St Jude worker of miracles pray for us St Jude helper of the hopeless pray for us Say this prayer 9 times a day by the 9th day your prayer will be answered Publication must be promised AMK

Novena to St Jude May the sacred heart of Jesus be adored glorified loved and preserved throughout the world now and forever Sacred Heart of Jesus pray for us St Jude worker of miracles pray for us St Jude helper of the hopeless pray for us Say this prayer 9 times a day by the 9th day your prayer will be answered Publication must be promised AMK

Novena to St Jude May the sacred heart of Jesus be adored glorified loved and preserved throughout the world now and forever Sacred Heart of Jesus pray for us St Jude worker of miracles pray for us St Jude helper of the hopeless pray for us Say this prayer 9 times a day by the 9th day your prayer will be answered Publication must be promised AMK

Novena to St Jude May the sacred heart of Jesus be adored glorified loved and preserved throughout the world now and forever Sacred Heart of Jesus pray for us St Jude worker of miracles pray for us St Jude helper of the hopeless pray for us Say this prayer 9 times a day by the 9th day your prayer will be answered Publication must be promised AMK

Novena to St Jude May the sacred heart of Jesus be adored glorified loved and preserved throughout the world now and forever Sacred Heart of Jesus pray for us St Jude worker of miracles pray for us St Jude helper of the hopeless pray for us Say this prayer 9 times a day by the 9th day your prayer will be answered Publication must be promised AMK

Novena to St Jude May the sacred heart of Jesus be adored glorified loved and preserved throughout the world now and forever Sacred Heart of Jesus pray for us St Jude worker of miracles pray for us St Jude helper of the hopeless pray for us Say this prayer 9 times a day by the 9th day your prayer will be answered Publication must be promised AMK

Novena to St Jude May the sacred heart of Jesus be adored glorified loved and preserved throughout the world now and forever Sacred Heart of Jesus pray for us St Jude worker of miracles pray for us St Jude helper of the hopeless pray for us Say this prayer 9 times a day by the 9th day your prayer will be answered Publication must be promised AMK

Novena to St Jude May the sacred heart of Jesus be adored glorified loved and preserved throughout the world now and forever Sacred Heart of Jesus pray for us St Jude worker of miracles pray for us St Jude helper of the hopeless pray for us Say this prayer 9 times a day by the 9th day your prayer will be answered Publication must be promised AMK

Novena to St Jude May the sacred heart of Jesus be adored glorified loved and preserved throughout the world now and forever Sacred Heart of Jesus pray for us St Jude worker of miracles pray for us St Jude helper of the hopeless pray for us Say this prayer 9 times a day by the 9th day your prayer will be answered Publication must be promised AMK

Novena to St Jude May the sacred

Cash in!

It's that Garage Sale time of year.....

With your Observer & Eccentric Classified Garage Sale Ad, you can instantly convert your unused art, that old chair, those mismatched golf clubs or Junior's road weary bike into cold hard cash!

Call us today to schedule your garage sale ad and clean house....
and cash in!



THE
Observer & Eccentric
NEWSPAPERS

CLASSIFIEDS
1-800-579-7355
www.hometownlife.com

Market Place

All Ads Run Online FREE! A Value Of Up To \$87.00 www.hometownlife.com

7100 Estate Sales (7100)

ANOTHER GREAT ESTATE SALE BY IRIS Fri Sat March 26 & 27 10-4 29146 W Wellington In Wellington Sub

60 YEAR S COLLECTION AN ESTATE WITH TREASURES GALORE CONTENTS INCLUDES Wedgewood china serv for 12

248-217-7161 248-626-6335 Appraiser & Liquidator for 40 Yrs in Metro Area

BIRMINGHAM ESTATE OF 98 YEAR OLD ECLECTIC WOMAN Dolls records books glass & china

ESTATE SALE Good Stuff Gotta Get 30665 Woodgate Dr 1 blk E of Evergreen S off 13 Mile Rd Sat & Sun

ESTATE SALE March 27th & 28th 9am 3pm 6933 Moccasin Westland MI 48185

ESTATE SALE Fri & Sat 3/26 & 3/27 9 TOOLS Every thing under to sell fast!

ESTATE SALE Sat 3/27 10 3 & Sun 3/28 11-4 17940 Fairway Livonia (Wayne & Curtis) Everything must go!

ESTATE SALE 42135 Hystone Dr Canton On Lilley Rd btwn Ford & Cherry Hill Sat & Sun 8-4

Call to place your ad at 1-800-579-SELL(7355)

7100 Estate Sales (7100)

HOUSEHOLD SALES CONDUCTED BY Lilly M. & COMPANY Call Toll Free 1-800-558-8851

LIVONIA Absolutely the best! Antique Furniture oak hall tree oak desk tables etc

SOUTHFIELD ESTATE SALE Dining room table/6 chairs/2 leaves \$500

Garage Sales (7110)

BIRMINGHAM Friday 9-5 pm indoor 559 East S Lawn misc furniture stove

CANTON HUGE SALE! Mar 25 27 9-4 S/Warren E/Morton Taylor 8933 Carnegie Hills Lots & Lots!

Earn extra \$\$ advertise with O & E 1-800-579-SELL

CANTON/PLYMOUTH MOVING/GARAGE SALE 7626 W Claymore Ct Rolling Ridge Subdivision off Warren Rd

March 27th 9-5pm 2 ice boxes 2 rocker 1 book case 1 small table 1 wash stand

WHITE LAKE 15 Family/26 Kid Garage Sale 412 Rosario Lane (off Union Lk Rd N of Cooley Lake Rd) Apr 1-3 9am 5pm

GARDEN CITY 32440 James S of Warren W of Hubbard Thur Sat 8am 5pm

Moving Sales (7130)

MOVING SALE MAR 26 27 18 08am 4 00pm Full contents of condo featuring rugs two Herex (11x7 and 10 x 6)

MOVING/GARAGE SALE 1515 Selma Westland (N of Palmer btwn Wayne & Newburgh) Mar 26 & 27 9-5

RATTAN SET 7 Piece Jimmie's Rustics Like new Complete w/wooden twin bedroom set

RAINBOW PLAYSET King Kong clubhouse package 2 Excellent cond! New \$6,000 asking \$4,000

Household Goods (7160)

\$100 double pillow top full size mattress/box set New in plastic w/warranty Can deliver 248 941 4206

\$110 double pillow top queen size mattress/box set New in plastic w/warranty Can deliver 248 941 4206

\$200 double-pillow top king size mattress/box set New in plastic w/warranty Can deliver 248 941 4206

BDRM SET Brand new 4 p cse still in boxes Must sell \$299 Can deliver 248 941 4205

Antique toys mahogany traditional classic living room dining room & bedroom furniture

Mahogany Interiors 506 South Washington Royal Oak (248) 545 4110

Art Oriental buffet Asian cabinet rugs rocking chair & more (248) 540 2889

CLASSIFIEDS WORK! 1-800-579-7355

Household Goods (7160)

Beautiful Mahogany Chippendale carved 10 pc dining room set Queen size 5 p mahogany four poster bedroom set

BED Sharp! Solid oak 74 w x94 long Headboard shelves on platform w/ 8 drawers \$500/best 248 608 6044

Bed \$100 Brand new warranty black leather sofa & loveseat w/chrome legs New warranty \$950 734 231 6622

BED SET 6 piece light oak & matching entertainment center \$950 Sofa bed \$250 Call after 5pm 248 789 1523

BEDROOM SET Dixie Campaigner boys 5 piece trundle beds w/matresses desk double dresser w/2 dressers 2 hutches \$250 (248) 851 3612

BEDROOM SET Henredon loveseats & tables 3 pc wall unit Player piano & lots more quality furniture Lawn furniture & tractor 248 642 6221

BEDROOM SETS 1 queen sz & 1 king size Henredon black lacquer (248) 499-8598

China Cabinet Mahogany Oval w/4 chairs (Colored DUNCAN PHYFE style)Rate 44 w x70 h x17 d Can email add'l measurement/photo \$1750 734 449 9222

COFFE TABLE Ethan Allen 18 th century series ball & claw Mahogany currently \$1200 will sell \$600 Sofa 84 Ethan Allen Preston green velvet sells new \$2100 will sell \$1000

DESK + CREDENZA Sleigh cherry beautiful & like new Retail \$13,800 asking \$4,000 or best offer (248) 642 7892

DESK + CREDENZA Lawyer's impressive solid walnut 401 and bookcase 248 514 4041

DINING TABLE custom made 72" x 28" leaves dark burl wood matching 80 buffet \$3250 248 332 3131

DINING ROOM SET Stanley table w/4 chairs Med Cherry 4 yrs old \$1095 734 464 6889

DINING ROOM SET 38 round table incl 2 leaves 5 chairs \$150 313 535 3955

Household Goods (7160)

DINING TABLE 8 mo old dark wood 5 chairs originally \$1800 some scratches \$700 firm Call 248 628 6968

ENTERTAINMENT CENTER Matching cocktail & end table \$800 (new \$2000) will separate (734) 591 9218

Furniture - Leasing State Must sell will sacrifice our house full of near new furniture includes elegant italian leather sofa & matching love seat cost over \$3000 sell both pcs for \$1650 also have gorgeous 11 pc formal cherry chippendale dining room suite cost over \$8000 will sacrifice for \$3150

HUGE SALE! Office desks cabinets work stations chairs shelving electrical material machinery & lots of misc Mar 24 26 9am-4pm 38147 Abruzzo Dr S of Ford E of Hix Westland

EXEC OFFICE SUITE lateral files reception station conference table/chairs like new make offer 248 505 8728

Camera & Supplies (7280)

CAMERA SHOW Sun March 28 10-3 HOLIDAY INN SOUTHFIELD Telegraph Rd S of I 696

FURNITURE-Moving, MUST SELL! Dining room set oak table w/chairs & leaf glass top coffee & 2 end tables queen size bed chest of drawers & end table hide a bed couch stand up kitchen table w/4 chairs All like new (248) 476 6068

Furniture used misc furniture at least 50% off original price 734 789 8928

ORIENTAL RUGS beautiful hand made 5 ft round blue & white Red tones 12 ft runner & two 29 x 44 Low price for all \$1300 248 693 8020

SOFA & CHAIRS excellent cond \$750 (734) 261-4067

SOFA & LOVE SEAT Matching contemporary sofa 94 Must sell \$500/both 313 550 0890

WABECK CONDO being remodeled Contemporary fur nishings and fixtures for sale many beautiful items priced to sell Please leave name & return phone number if no answer 248 797 0955

Appliances (7180)

ELECTRIC DRYER Used 2 mos \$150 (313) 531 1472

MAYTAG NEPTUNE 2002 Washer/dryer front load 6 mos use \$950 734 459 6055

Refrigerator side by side 25.5 cu ft \$1400 Self cleaning gas range \$400 Both 1 yr old 734 416 8028

Appliances (7180)

STOVE SELF cleaning elec tric like new \$150 Vented microwave \$75 734 451 9645

Exercise/Fitness Equipment (7215)

Pro Form Elliptical & Treadmill never used Cost a \$1000 sell for \$450 (248) 489 1049

SKIER Nordic Track Achiever Perfect condition \$250 /best (248) 354 2619

Business & Office Equipment (7240)

EXEC OFFICE SUITE lateral files reception station conference table/chairs like new make offer 248 505 8728

Camera & Supplies (7280)

CAMERA SHOW Sun March 28 10-3 HOLIDAY INN SOUTHFIELD Telegraph Rd S of I 696

Furniture used misc furniture at least 50% off original price 734 789 8928

ORIENTAL RUGS beautiful hand made 5 ft round blue & white Red tones 12 ft runner & two 29 x 44 Low price for all \$1300 248 693 8020

SOFA & CHAIRS excellent cond \$750 (734) 261-4067

SOFA & LOVE SEAT Matching contemporary sofa 94 Must sell \$500/both 313 550 0890

WABECK CONDO being remodeled Contemporary fur nishings and fixtures for sale many beautiful items priced to sell Please leave name & return phone number if no answer 248 797 0955

Appliances (7180)

ELECTRIC DRYER Used 2 mos \$150 (313) 531 1472

MAYTAG NEPTUNE 2002 Washer/dryer front load 6 mos use \$950 734 459 6055

Refrigerator side by side 25.5 cu ft \$1400 Self cleaning gas range \$400 Both 1 yr old 734 416 8028

Lawn/Garden Material (7480)

Rear bagger for 13 hp Craftsman rider & plow blade \$150/all 313 715 0191

Miscellaneous For Sale (7500)

Factory Refurbished Spa Never used was \$6K now \$3K Will deliver Call toll free now 1 866 858 7727

FREE 4 ROOM DIRECTV SYSTEM INCLUDING INSTALLATION! FREE 3 MONTHS HBO (7 movie channels) w/subscription Access 225+TV Channels Digital quality picture/sound Limited offer Details 1 800 963 2904

HOMEOWNERS WANTED! Kayak Pools is looking for Dome Homesites to display our New Maintenance Free Kayak Pool SAVE thousands of \$\$\$ with this unique opportunity CALL NOW!! 1 800 31 KAYAK Discount Code 106 L15

JANITORIAL FURNACE new 7500btu 80% eff fits any where \$500 248 476 3178

Moving All fixtures appliances washer/dryer blinds etc Must go! 248 760 1904

Musical Instruments (7510)

ACOUSTIC GUITAR Taylor 510 New Premium Mahogany \$1800 or best 734 981 9199

BABY GRAND Marshall & Wendell Olds English dark walnut and lots of style Perfect for mansion large or small 248 646 1322

BABY GRAND PIANO Walnut finish bench Very good cond \$2500/best 248 349 5456

CONSOLE PIANO Kimball Pecan Wood very nice condition You Haul Rochester Hills \$700 248 373 3473

PIANO 91 Yamaha Upright Black Lacquer finish in exec cond w/bench Make offer (248) 661 2219

PIANO Baldwin Hamilton w/bench Mahogany finish queen ann legs like new cond \$3200 (734) 455 0351

POOL TABLE Brunswick 8 slate Mint cond You move \$1200/best (313) 299 0447

POOL TABLES All State antique ultra modern bar size Buy direct from factory 248 399 7255E 248 547 3980

Wanted To Buy (7540)

A 1 RECORD BUYER Buying records dj juke box private collections large or small Vogue p cture discs (734) 425 4931

Birds & Fish (7820)

UMBRELLA COCKATOO 5 yrs old Cage & toys \$1200 Very good bird Female (734) 261 2084

Dogs (7840)

AKITAS AKC Large bone 3 mos old 3 males shots parents on site \$550 (734) 425 7137

GERMAN SHEPHERD AKC PUPPIES Champion bloodline pedigree black/lan 6 wks 1st shots \$500 734 461 4000

LAB/MIX 2 years old large Needs good home Good with kids & pets 248 982 4171

SHIH TZU Imperial Teacup Adorable female red & white 13 wks Vet checked 2nd shots \$500 Deposit accept ed (313) 215 4954

SHIH TZU PUPS AKC 35 yrs exp Shots & wormed Non shed 248 887 9698 or 248 343 2068

Dogs (7840)

WHEATON PUPS Soft coated AKC Non shed non allier gemic Health guarantee (517) 529 2930

Lost & Found Pets (7930)

FOUND Small old male terrier mix 8 Mile & Telegraph Brown & black 248 557 1636

FOUND Black lab 3/12 Purple shock collars Clarkston/Eston 248 394 1253

FOUND CAT Garden City by Ford Rd and Middlebelt in Oct Torti colored 248-474 6997

FOUND Female dog 1 yr 7 55# S Call & describe dog Canton area 734 547 8281

LOST CAT white green eyes 12 lbs deaf front paws declawed reward (248) 723 4295

LOST CAT Black w/Gold green eyes female Ann Arbor Trail & Inkster area Reward (313) 561 5365

Michigan Humane Society ADOPT-A-PET This Week's Featured Pet Bubby is an adorable 2 year old Terrier mix He is a sweet and friendly pooch who enjoys sitting on laps and cuddling He is also very smart and is already housetrained and knows how to "sit" Bubby To welcome Bubby into your life, VISIT THE Michigan Humane Society Westland Shelter 734-721-7300

Home and Service Guide

All Ads Run Online FREE! A Value Of Up To \$87.00 www.hometownlife.com

Home & Service Guide 0001-2450 Aluminum Siding (0060)

GAGNER HOME IMPROVEMENT Siding Trim Gutters Awnings Roofing Lic & Ins (734) 281 0303

JOE S BRICK REPAIR Small jobs welcome Tuck Pointing Brick Repair Insured (248) 478 7549

DOGONSKI CONSTRUCTION Brick Block & Cement Work Porches Chimneys Dr Ways Free Est 313 537 1833

Classifieds 1-800-579-SELL www.hometownlife.com

Advanced Poreh & Concrete All types of cement & masonry work Quick Service!! Sr Discount 734 261 2655 NO JOB TOO SMALL!

ALESIA MASONRY All types of masonry work Tuck Pointing Steps Porches Chimneys Foundations John (734) 673 0978

ALL CONCRETE Drives porches patios walks Brick block foundation work Lic & Ins Free Est Call anytime Todd Humecy 248-478 2602

ATINA CEMENT All types of cement work Driveways garages patios Free Est Lic & Ins 734 513 2455 248 350 2973

AL S CONSTRUCTION Garage building & removal Debris removal Call today 734 844 1658

ALL PHASE CONSTRUCTION All you home imp needs, Big & small jobs Int/Ext Complete kitchens & baths Venetian plasterers Lic & Ins Free est 313 532 2520 313 570 2498

CLASSIFIEDS THAT WORK FOR YOU! 1-800-579-SELL

BARRY'S CARPENTRY Basements Bathrooms Additions Kitchens 23 yrs exp Start to Finish Lic/Ins (248) 478 8559

FINISHED BASEMENTS Custom Bars Baths Kitchens Complete job start to finish 25 yrs exp Lic/Ins Northshire Corp 248 628 1400

JM GALLAGHER Construction Siding gutters replacement windows & doors Also bsmt remodeling Est 1981 Free est (313) 414 3355 Lic# 2101152476 Fully ins

Ml Basement Makeovers Clean up the appearance of those ugly stone walls. Most basements as little as \$2000 Neil s Contr 248 684 8706

Ree Room Kitchen & Bath Specialists All Remodeling Formica & Laminate Visa/MC AMEX 248-476 0011 313 835 8610

FINISH CARPENTRY Crowns Trim Doors Railings Straight or Bent Lic 30 yrs exp 734 455 3970

BEST CHIMNEY & Roofing Co New & repairs Sr citizen disc Lic & Ins 248 557 5595 313 292 7722

COLEMAN CEMENT All types of cement work Rick Coleman (313) 538 8279

DECKS/PATIOS/Sunrooms AFFORDABLE CUSTOM DECK Volmanized or Cedar Lic/Ins Free Est 20 Yrs Exp 734 261 1614 248 442 2744

ANOTHER QUALITY JOB BY SUPERIOR Custom Decks Gazebos & More Maintenance Free Available Lic builder Fully insured (248) 866 0777

Don't Lose This Number! O&E Classifieds 1-800-579-SELL

MICHIGAN DECKS INC Custom decks wood & main tenance free licensed & insured 248 219 6927 michigandecks.com

Drywall DRYWALL FINISHING • TEXTURES • PATCHWORK • Free Est Reasonable Prices John 734 722-6855

DRYWALL FINISHING 30 yrs experience No job too small 734 728 9599

Electrical PROBLEMS? 32 yrs exp Storm damage www.mattocino.com Small jobs welcome (734) 654 1004

Floor Service Brennan's Authentic Floors Installation & refinishing Quality work & prices 15 yrs exp Lic Ins 734 513 8570

Hardwood Floor Specialist Install Sand Finish & Repairs 22 years exp Reasonable rates 734 968 0609

Garage Door Repair Garage Door Springs and door openers Repaired/replaced Avail Sun 248 640 6298 CELL

ARMAN GUTTERS LC Seamless Copper Installation ETC Free Est 313 204 6133

CLEANING SCREENING NEW & REPAIRS 248-471-2600

GUTTER CLUTTER Spring Cleanouts avail Cleaning & screening \$50 Colonials/540 Ranches Tim 734 542 9537

Handyman M/F Absolutely Lic/Ins DU IT ALL Specials Ceramic tile Formica & Coran tops & kitchens. We also do complete basements & all other interior work including electrical & plumbing etc (248) 889 7667

AFFORDABLE PRICES! All types of work licensed Electrical Commercial & Residential (248) 219 0873

ALL TIMEHART HANDYMAN All phases of home improve ment Free est Sr Citizen Disc Best any bid! 734 467 7798

Hauling/Clean Up A 1 Hauling Move scrap metal clean basements garages stores etc Lowest prices in town Quick service Free est Wayne/Oakland City Central location 547 2764/559 8138

AFFORDABLE PERSONAL HAULING SERVICE We clean out homes attics basements garages offices warehouses & anything else Complete demolition from start to finished Free est Demolition 248 354 3213

KITCHEN/BATH REMODELING & other home improvements Free estimates Over 40 yrs exp (586) 755 7755

KITCHENS BATHS BSMTS Local no Free estimates Best value super references Office phone 734 737 9778

HOUSECLEANING Personalized quality service gear Employee background screening Ins & bond provided 24 yrs experience OLD MAID SERVICE 248 478 3240

Call Natalie 734 331 2333 Efficient & Reliable \$65

Affordable Cleaning Service Home Office Commercial Great Rates 248 787 0052 Avail 24/7 734 377 4511

Home & Coml Cleaning We get all the corners Bonded & insured Reasonable rates Call Deb at 248 890 3800

HOUSE CLEANING Starting at \$50 weekly \$55 bi weekly \$60 monthly Ins & bonded Ref 734 455 5435

LANDSCAPING CRIMBOLI NURSERY Re landscaping/Brick Pavers • Tree & Evergreens/Hardgood Deliveries/Free Estimates Visit Our 20 acre Nursery 50145 Ford Rd Canton 734-495 1700

MR SHOVEL Resodding Lawns Brick Pavers Drainage Low area repaired Demolition/Pool Removal Dirt Concrete Removal Paul 734-326-6114

SUMMER LAWCARE G & G Landscaping Great spring rates! 10+ yr exp Free Est 248 321 8620

LAWN SPRINKLERS Landscape & design Hydroseeding Sod Brick Pavers Grounds Maintenance etc Insured 734 564 1275 www.naturegreenservices.com

IMAGINE OUTDOOR Quality Lawn Maintenance Spring Clean up/mulch Bush trimming (248) 478-1099

AFFORDABLE MAINTENANCE Spring Clean-ups Douglas (248) 366 9585

BRAD S LAWN & LANDSCAPE Lawn Yard Garden Main Sping Clean ups Odd Jobs Free Est (734) 564 0993



BUSINESS OPPORTUNITY: Profits are always growing! Barbershop for sale — high-traffic location, two chairs, 400 square feet, \$60,000. Get in on a great opportunity now and retire in Barbados later — I am! Call Harry, 000-0000.

CE S... Downtown

There's TRUST

in classified advertising!

Newspaper classified advertising is the most reliable source for connecting buyers and sellers.

Whether your newspaper is delivered to your doorstep or your computer, you can always count on your Observer and Eccentric classified section to bring you the best local classifieds around.

In print or online, when you come to The Observer & Eccentric Newspapers, you come to the right place. It's what you trust!

We work for YOU!

For the best in local
classified advertising visit
www.hometownlife.com

Observer & Eccentric

1-800-579-SELL



All Ads Run Online FREE! A Value Of Up To \$87.00 www.hometownlife.com

Automotive Classifieds

Boats/Motors 6020

14 ft aluminum boat 1998

CATALINA 27 Sailboat 1983

CHRYSLER 1976 14 ft Tri Haul

FOUR WINNS 325 EXP 1992

HONDA 1999 BF 15/15 hp 30

LUND 2000 Alaskan 16ft 40

Marlboro boats (3) (Canoes) Two man

PONTOON 1997 Premier Grand

SEA DOD 1997 GTX 52 hrs

SEA RAY 1986 Sundancer

SYLVAN 1989 ALUM 17R

THOMPSON 1995 20 cuddy

WELLS CRAFT 1998 175 HP

Motorcycles/MiniBikes/Ga-Karts 6070

HARLEY HERITAGE Springer

Harley Davidson Heritage

Harley Davidson Softail

HARLEY DAVIDSON 1999

HONDA SHADOW 42 2703

KAWASAKI NINJA 2001 Blue

YAMAHA V STAR 1100

Snowmobiles 6110

POLARIS 1998 XC700 97

Campers/Motor Homes/Trailers 6120

MINNIE WINNIE 1999 DX RV

R VISION S TRAIL LITE

SPORTSMAN 1996 18 ft

SUNNYBROOK 27 FKS 2002

TERRY LITE 1999 25 extras

TRAILER 2000 us cargo land

YELLOWSTONE 1985 30 ft

LUND 2000 Alaskan 16ft 40

Used Cars Wanted 6190

ALL AUTOS TOP\$\$

Trucks for Sale 6220

CHEVY SILVERADO 2001 Wk

CHEVY Silverado 2002 3/4

DODGE 2000 DAKOTA SLT

DODGE DAKOTA SLT 2002

DODGE RAM 2002 1500

F 250 2003 15 5K exc cond

FORD 1999 F150 Extended

FORD 1999 F150 Extended

GMC 1994 SONOMA 6 cyl

SIERRA 1999 GMC Z71

Mini-Vans 6240

Dodge 2000 Caravan exc

FORD AEROSTAR XLT 1995

GMC 1997 SAFARI SLE 55k

GRAND VOYAGER 1999 SE

Vans 6260

DODGE 1997 Van Conversion

DODGE RAM 1996 Newly

FORD 1999 E250 Cargo Van

GMC 1992 Safari AWD

GMC 1998 Savana 3500 cargo

4 Wheel Drive 6200

CHEVY 1989 4x4 auto V8 1/2

BLAZER 1994 4x4 69k tow

BLAZER 2000 ZR2 60k mi

BLAZER 2002 LS air cruise

BLAZER 2002 LS loaded low

DENALI 2002 XL black

ESCALADE 2002 Extremely

EXPLORER 2004 XLT high

FORD EXPLORER 2000 Good

GM ENVOY XL 2002 SLT

Landrover Discovery II 2000

NISSAN XTERRA 2001 5 spd

Subaru 2001 Forester L

TRAIL BLAZER 2002 LT

Xterra 2000 SE 4x4 5 speed

Sports & Imported 6300

BMW 1998 535i fully

BMW 2001 740i

Infiniti 2002 Q45 sport

Sports & Imported 6300

RALPH THAYER AUTOMOTIVE

2001 Passat \$229/mo

34501 Plymouth Rd

SUZUKI 2003 Aero SX low

CADILLAC 1955 Fully

CHEVROLET CAPRICE 1975

ELDORADO S 1993 2

FORD GALAXY 1965 390

3 2 TL 2000 55k exc cond

BUICK LASABRE

2001 Buick Wildcat

2002 Buick Wildcat

2003 Buick Wildcat

2004 Buick Wildcat

2005 Buick Wildcat

2006 Buick Wildcat

2007 Buick Wildcat

2008 Buick Wildcat

2009 Buick Wildcat

2010 Buick Wildcat

2011 Buick Wildcat

2012 Buick Wildcat

2013 Buick Wildcat

2014 Buick Wildcat

2015 Buick Wildcat

Chevrolet 6400

CASH Dealer will sell on

CAVALIER 1992 Coupe 78k

CORVETTE 1996

IMPALA 2003 p/w/CD only

LUMINA 1992 Euro 3 1 red

MALIBU 2003 silver loaded

MALIBU S 1999 2014 15

MONTE CARLO 2002 SS red

PRIZM 2001 air auto cruise

SAVANA 2001 Cruise

CONCORDE 2004 LX 7K fac

LHS 1994 leather extra clean

AVENGER 1997 Good cond

INTREPID 1995 Auto 100K

INTREPID 1999 59K

Dodge 6440

INTREPID 2000

NEON 1999 auto all power

NEON 2000 Sport auto air

NEON 2001 Exc cond 70K

NEON 2003 RT leather moon

STRATUS 2004 SE 4 dr white

CASH Dealer will sell on

ESCORT ZX2 1999 69K auto

FOCUS 2002 ZX3 18K 5

MUSTANG 2000 GT dark red

MUSTANG 2001 GT convertible

TAURUS 1997 leather power

PRISM 1994 great cond

ACCORD EX 2003

ACCORD EX 2003

CIVIC 1995 EX Black 129k

CIVIC 2000 EX 53k mi 2

CRV 1997 Awd auto power

DEL SOL 1993 COUPE

Honda 6520

TAMAROFF Green Tag Sale

Accord 2002 LX 4 dr

Accord 2002 LX 4 dr

Cherokee 1994 Sport 4 dr

Cherokee 2001 LTD 4x4

Cherokee 1999 Exc

Cherokee 2003 Laredo

Fox Hills Chrysler-Jeep

Cherokee Laredo

Lexus 300ES 1996 CD

FX300 AWD 2000 CD 1

Lincoln 6560

MARK VIII 1999 Firethorn

MIATA 2000 Convertible LS

Mercury 6600

COUGAR 1999 V6 black

MYSTIQUE 1998 LS Green

Nissan 6520

TAMAROFF Green Tag Sale

Maxima GLE \$13,988

Sentra 2001SE \$10,988

Altima 2003 S \$14,988

Nissan Certified TAMAROFF

AURORA 2001 sunroof white

CUTLASS SUPREME 1987

DELTA 1999 98 50th

INTRIQUE GLS 2001 Sun

GRAND CHEROKEE 2003

Lexus 6540

Bonneville 2002 SLE

Bonneville 2001 Loaded

Grand AM 2001 GT sedan

Grand Prix 2001 GTP

TRANS AM 1994 - White

TRANS AM 2000 Pawter

Pontiac 6600

TRANS AM 2000 Black 14K

TRANS AM 2001 Ram air

VIBE GT 2003 6 speed trans

Salurn 6700

WAGON 1997 low miles

Toyota 6720

AVALON 1998 - Gold pkg

CAMRY 2000 LE 129K hgw

Volkswagen 6740

BEETLE 2003 GLS turbo auto

CABRIO 1998 Convertible

CABRIO 1998 69K green/tail

NEW BEETLE 2001 turbo

PASSAT 1998 Turbo 52k

PASSAT 2002 GLS 6 cyl

Bonneville 2002 SLE

Bonneville 2001 Loaded

Grand AM 2001 GT sedan

Grand Prix 2001 GTP

TRANS AM 1994 - White

TRANS AM 2000 Pawter

Ford Escort 1994 4 Dr

Honda Accord 1990 Good

VOLKSWAGEN 1998 FOX

Volvo 6760

Dick Scott's Used Car Best Shots of the Week!

Dick Scott's Used Car Best Shots of the Week!

Switch to LaRiche SIGN & DRIVE! - NO MONEY DOWN - NO FIRST PAYMENT - NO SECURITY DEPOSIT

Allstate 1-800-Allstate

Automotive

Classifieds inside

To place an ad call toll free
1-800-579-SELL (7355)
Fax (734) 953-2232

Observer & Eccentric | Thursday March 25 2004

The 2004 Lexus RX 330

Advertising Feature

Thursday DriveTime



BY DALE BUSS

Review by Dale Buss

Just when you think that automotive excellence can't get any better than a Lexus sport-utility-vehicle, you're proven wrong - but only because Lexus brings out a new SUV. Thus the fact that the 2004 Lexus RX 330 actually represents an improvement over the vehicle it replaced, the RX 300, is quite an achievement in its own right.

It was no small matter for Lexus, the luxury division of Toyota, to decide to replace the RX 300 in the first place. Introduced in 1998 and with a growing number of challengers, RX 300 remained the best-selling luxury SUV not only in America but throughout the world. But typical of the approach that has made Toyota the world's most-emulated auto maker, Lexus didn't rest on the RX 300's laurels.

Lexus actually calls the RX 330 a "luxury utility vehicle" and has attached the acronym "LUV" to it. Characteristic of the best SUVs on the road these days, RX 330 is based on a unibody car platform rather than a truck frame. So it doesn't perform off-road like the most rugged SUVs, but it gives today's mainstream SUV buyers what they're really searching for - more cargo room than a sedan as well as that over-the-traffic positioning and sense of security that is a key attribute of SUVs.

At a suggested retail price of \$36,425 for the version I drove, the 2004 RX 330 is longer and wider than the model it replaces. It comes with a leather interior that feels soft and warm and inviting with splashes of real wood trim. The front seats are positioned off the floor at a comfortable chair height and are snug and supportive and the back seats are roomy and comfortable.

The styling of the RX 330 is pleasingly sleek and much less clunky than its predecessor RX 300. The bulky front end lends some substance to the design, and the visor over the rear window is a nice distinctive touch as well. Other notable features are the



The Lexus RX330 is a "Luxury Utility Vehicle" or LUV.

clear-lens tail lamps that Lexus SUVs have helped make popular.

Still, it's in the going that the RX 330 makes its most impressive showing, like most Toyota and Lexus vehicles. The 3.3-liter, 230-horsepower 24-valve V6 engine with continuously variable valve timing, coupled with a five-speed automatic transmission and full-time all-wheel-drive, make a perfect combination that provide yet another example of the effortless driving that is required of a Lexus vehicle. Mileage is pretty satisfactory for an SUV, at 28 miles a gallon in the city and 24 mpg on the highway.

It isn't just that the power is more than adequate for any occasion but that so little work seems required by the engine to provide it. It isn't just that the handling is precise but that it seems so natural to driving the vehicle that you almost don't notice how outstanding it is. The steering is light yet retains a feeling of firm control, it's accurate without being slavish to every little tweak of your hand. The vehicle's independent suspension keeps the tires of the RX 330 in contact with the road for very sufficient grip.

The brakes also are worth noting. Large discs front and rear, they work very smoothly and provide very good feel to the driver. In part that's because the latest braking technology is on board the RX 330 - a four-sensor/four-channel anti-lock brake system that helps the driver maintain control of the steering

under hard braking. Electronic brake force distribution balances braking forces for shorter stops. Brake Assist senses when the driver is in a panic braking situation and helps ensure full force is being applied. Inside, too, the RX 330 offers a level and execution of styling, comfort and amenities that have come to place Lexus on a pedestal even within the luxury-car segment. Lexus's industry-leading LCD screen displays ventilation, audio, trip computer, outside temperature and clock functions efficiently and is easy to work with.

In RX 330, the display also offers a view of what's behind the vehicle when the driver is backing up, so he or she won't hit anything. RX 330 is one of a growing number of vehicles that are doing this, and they all seem to use a fish-eye lens that so severely distorts what is behind you that it cuts down on the effectiveness of the device. To me, that begs the question: Why couldn't such cameras somehow use regular lenses or be mounted higher on the vehicle? In the case of RX 330, the visor over the rear window already hosts the radio antenna, couldn't a small camera be fitted up there as well?

But of course, that's reaching not even for a complaint but for a question. And if you've got to do that to find fault with a vehicle, you should go out and buy it first.

Write Dale at daledbuss@aol.com

CLASSIFIED INDEX

CLASSIFICATION	NUMBER
Employment	5000-5999
Announcements	6000-6900
Merchandise	7000-7940
Autos/ RVs	8000-8780
Boats/ Motors	9020
Motorcycles/ Motorbikes	9070
Trucks	9220

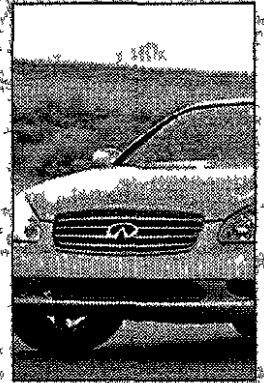

Call Toll Free
1-800-579-SELL (7355)

Fax Your Ad: (734) 953-2232

Walk-In Office Hours

Monday - Friday 8:30 a.m. to 5 p.m.
After Hours Call (734) 951-0900

Deadlines: To place, cancel or correct ads.

Sunday	5:30 p.m. Friday
Sunday Real Estate	5:30 p.m. Thursday
Thursday	6 p.m. Tuesday
Thursday Real Estate Display	3 p.m. Monday

View the Observer & Eccentric Automotive Classifieds on the web:

www.observandeccentric.com



Call 1-800-226-9950
\$2.19 per minute,
\$2.19 per call connect fee

DEVOTED

SWF 33 mother of three 56 auburn hair brown eyes easygoing and funny. Enjoys fishing, camping, boating, gardening, cooking and more. Seeking a SWM 34-45 for a possible long term relationship. Ad# 472296

LOVING & HONEST

SBF 30 58 175 lbs w/ dark skin and a full figure. In search of a down to earth SWM under 45 who is easy to talk with for companionship and quiet times together. Ad# 496909

ARE YOU FOR ME?

Very attractive SBF 34 seeking financially secure gentleman over 35. Talk first. Ad# 496980

OLDER LOVE IS SWEETER

Are you interested in meeting a sweet classy gal early 60's beautiful brown hair and eyes who is looking for a tall, mild mannered 58-70 year old gentleman emotionally and financially secure. Ad# 403903

TAME MY HEART

SWF 65 52 130 lbs. She is adventurous loves to travel dine out stay active and much more. Seeking a SWM 55-70 who does not take life for granted and has similar interests. Ad# 496608

WINK AT ME

Energetic vivacious sweet SWF 64 51. Interests are the Arts, opera, dancing, good conversations and intellectual discussions. Seeking a caring fun loving SWM 65-75 for a possible relationship. Ad# 488495

PATIENTLY WAITING 4 U

SWF 60 auburn hair green eyes professional Enjoys travel week end get a ways camping, outdining and more. Seeking a SWM 57-70 who is loving humorous N/S N/D fun and affectionate. Ad# 405309

STARTING OVER

Divorced white female 37 blonde blue eyes 5'3 med um build great personality. Interests include camping, outdoors sports, travel, dining out and dancing. Looking for single white male 37-47 with same interests. Ad# 482787

MY IDEAL MAN

SWF 36 57 sexy mom sincere with some college. I like kick box, jogging, exercising, swimming and much more. I can offer honesty, sincerity, dedication to an educated family-oriented SWM 30-43. Ad# 494134

SHARE A MOONLIT NIGHT

Bubbly SWF 54 135 lbs red dish/blonde hair hazel eyes. Enjoys bowling, sports and exercise. Looking for a sincere good humored SWM 50-62. Ad# 493215

A REAL GEM

Green eyed appealing WWF 49 57 humorous homemaker aggressive. Loves the outdoors, gardening, travel and sports. Seeking a SM 39-70 companionate and nice looking. Ad# 488338

CALL ME
SWF 33 smoker occasional drinker. Enjoys swimming, bicycling, works on aquariums. Seeking SWM 28-43. Sound interesting? Ad# 485274

GOOD FRIEND
Semi retired SWF 59 56 with blonde hair stays busy. Like home life, family, gatherings, dances, fitness. Seeking reliable good hearted SM any age. Ad# 484727

HOLD MY HAND
SWF 43 55 with a wonderful personality. My hobbies include camping, walks on the beach, bowling, horse sports and sun sets. Would like to meet an honest caring SWM 35-55. Ad# 481648

GOOD NATURED
SWF 55 61 medium build college graduate non smoker. Enjoys working out, theater, movies, walking and more. Seeking a SWM 63 plus 53-62 who is well groomed and professional for friendship. Ad# 470261

BEAUTIFUL INSIDE & OUT
SWF 57 54 red curly hair brown eyes. Enjoys movies, theater, boating, swimming, cooking and time with family. Seeking a SWM 55-79 who is ambitious, spiritual, successful and fun. Ad# 473611

FAITHFUL
Outgoing compatible SWF 19 56 who currently is a stay at home mom enjoys movies, dining and spending special times with an honest SWM under 30 who is more of a "thug". Ad# 483283

MARRIAGE MINDED
Professional SWF 50 who enjoys socializing, the outdoors, cooking and more. Seeking a companionate caring SWM 43-52. Ad# 482898

INTERESTED?
SWF 44 enjoys church, plays good conversation, singing and more. Looking for a SWM 40-46 with a similar interests. Sincere replies only. Ad# 482616

ALL MY LOVE
SWF 37 who is hoping to meet a SNAM on the same age. If it's you call me! Ad# 482471

SOMETHING REAL
SWF 25 blonde hair blue eyes bubbly, friendly and easy to get along with. Enjoys computers, movies, good conversation with friends and more. Seeking a SM who is honest, trustworthy, humorous and open. Ad# 482193

NOT PERFECT
SWF 39 with two teens, physically challenged, works with care. Seeking relationship with SM 39-58 understanding and special. Ad# 473738

LIFE IS TOO SHORT
SWF 61 med um height with blue eyes and blonde hair. Enjoys staying active and having fun. Looking for a N/S SWM 58-65 who does not play head games. Ad# 420010

CUTE BLONDE WIDOW
I'm 5 105 lbs 58 rooking c secure SF seeking a nice looking male 57 to 6 slim to med um build who enjoys dancing, golf, live theater and good conversation. Macomb County. Ad# 403562

LOOKING FOR
Fun loving relationship 59 52 SWF brown hair medium build good personality. Friendly, compassionate like to meet a man 65-72 with the same. No games. Someone that I can be fun loving with and also serious pretty versatile with going out. Ad# 444245

THE OBSERVER & ECCENTRIC PRESENTS

Personal Scene

Place your FREE print ad, call 1-800-487-2038 24 hours/7 days a week

NOW THERE'S 3 GREAT WAYS TO RESPOND TO THESE ADS

1 1-800-226-9950
\$2.19 PER MINUTE
2 19 PER CALL
CONNECT FEE
charges will appear on your monthly telephone bill

2 1-866-899-5644
\$2.49 PER MINUTE
using your credit card you pay as you go charges will appear on your credit card statement

3 1-800-487-2038
use your credit card to purchase tokens for as little as \$34 per token or to respond FREE to ads

For even more ads visit <http://www.observersingles.com>

View a photo of this person online

Respond to this ad for FREE by calling 1-800-487-2038

View an expanded profile for this person online

SHARE LIFE
SFB 38 52 medium build kind loving and common sense. Enjoys reading, picnics, nature, boating, time with friends and family. Good conversation and much more. Seeking a SBF 35-50 who is handsome, easygoing, pleasant and has similar interests. Ad# 476614

CUTE
Petite SWF 51 owns many activities. Seeking a SWM under 48. Please call me. Ad# 478474

LET'S SEE WHAT BLOOMS
SWF 64 52 118 lbs 8 grade who is happy and outgoing. Interests are the outdoors, movies and gardening. Seeking a loveable and fun guy. Enjoys dining out and more. Seeking a companionate caring SWM 60-70 who is outgoing for companionship and possible relationship. Ad# 477392

GRADE AND ELEGANCE
SWF 60 caring mother owns life. SWM to enjoy life, someone who wants to casually date and has a sense of humor. Ad# 403942

WHERE ARE YOU?
50 yrs old DWF 52 110 lbs blue eyes brown hair. Enjoys music, concerts, outdoors. Harveys the Red Wings, dancing, etc. Searching for an honest, loyal SWM to enjoy life, someone who wants to casually date and has a sense of humor. Ad# 403942

RECIPE FOR LOVE
SBR 30 55 dark brown hair, hazel eyes. Interests are fun times watching basketball and wrestling and cooking. In search of SWM 30-35 tall dark hair, enjoys a good chef for possible relationship. Ad# 476002

IN GOD I TRUST
SWF 45 65 brown hair/eyes. Interests are a Church, after noon strolls and good conversation. Seeking SWM 30-65. Christ an enjoys children who is honest and caring for companionship and possible relationship. Ad# 475988

ROAD TO HAPPINESS
This family oriented outgoing SWF 32 enjoys scary movies, carnivals and long walks. She is seeking SWM 28-40 who is caring, likes children, down-to-earth and is sincere for a relationship. Ad# 475521

NEW TO THE ADS
Loving reliable SBF 21 52 150 lbs. extreme complexion. Enjoys basketball, football and more. Enjoys travel for a confident SWM who knows what he wants out of life. Ad# 471866

ENJOY LIFE
SWF 37 57 with blue eyes and brown hair. Interests are time with the children, camping, basketball, golfing, music and concerts. Looking for a SWM 30-45 who is fun to be around. Ad# 444655

ALWAYS SMILING
SWF 44 57 with brown hair and hazel eyes. Interests are swimming, shopping, NASCAR, fishing and much more. In search of a SWM 51-63 34-50 who is honest and trustworthy. Ad# 468434

WHAT'S IMPORTANT TO YOU?
SWF 56 56 average build with brown hair & eyes interested in gardening, dancing, swimming, cooking & romantic evenings. Looking for an honest, faithful SWM 51-60 with great eyes who loves children and intelligent conversation. Ad# 469108

AWESOME COOK!
Fun loving outgoing SWF 44 57 brown hair and green eyes. Loves to laugh. My hobbies include travel, swimming, boating and shopping. I'm searching for an honest, loving outgoing SWM 34-52 51-62 with a husky build. Ad# 469027

READ THIS!
SWF 32 57 enjoys going walks, rollerblading, biking, good conversation and motorcycling. She is searching for a sincere, attractive financially secure SWM 25-37 no drugs and no games! Ad# 469008

A REAL MAN
SWM young 53 long brown hair 5'9 165 lbs semi retired N/S. Seeking a nice looking AF 21-35 who is non materialistic and marriage minded. Ad# 495677

GOOD CATCH
Single white male SBF 39 59 enjoys many interests. Seeking a well read, educated SBF who knows herself. Ad# 485635

YOU AND ME
SWM 35 51 175 lbs outgoing, kind meeting new people in the area. Seeking educated SF under 55 who knows who she is. For dancing, drinks and much more. Ad# 485057

SOAR WITH ME
I am a SWM 60 pilot who enjoys sand and sun beaches, warm weather, flying, travel, etc. I would like to meet a SF 48-58 in the White Lake area. All calls returned. Ad# 481076

ALL AROUND GUY
SBM 26 63 275 lbs pretty smile, straight teeth, student, white vehicle. Seeking SF under 40 to spend time with. Ad# 497132

HARLEY WILL TRAVEL
Seeking adventurous woman under 55 for fun times with this SWM 54 who has a Harley bike. Ad# 496428

WANNA FALL IN LOVE?
Well built 5'9 165 lbs 39 year old SWM very hardworking likes to have fun and enjoys quiet times with that special woman. Looking for an honest, trustworthy SWF 25-45 to dining out, movies and dancing. Ad# 442480

WHY NOT?
Divo cedi sm with me a 59 61 enjoys outdoors, gardening, working in the house, the water and much more. Seeking a SF 40-50 who is female, fun y or oriented for friendship and possibly more. Ad# 403951

MILK CHOCOLATE
Charming outgoing SBF 25 6 160 lbs light complexion, interests include basketball, friends and culture. Seeking a SBF under 32 with a great sense of humor. Ad# 495724

THE TIME OF MY LIFE
Laid back SWM 57 6 who enjoys video games, sci art fairs and antique. Seeking an energetic, humorous SF under 50. Ad# 482880

A NEW START
SWM 22 510 dark hair green eyes 175 lbs outgoing and humorous. Enjoys sports, music, movies, going out with friends and more. Seeking a SWF under 26 who is honest, outgoing, kind hearted and fun loving. Ad# 480407

KISSES FROM ME
Athletic outgoing energetic and happy SWM 43 59 who enjoys sports, working out, animals and more. Seeking an honest caring warm and sensitive SF 35-50 who can rely on an intelligent conversation. Ad# 488065

RELAXING TALKS
Extravagant SBF 31 who enjoys working out, softball, games, music and shooting pool. Seeking a fun and exciting SF over 31. Ad# 482397

A COMPANION
KIND successful and attractive SWM 32 59 170 lbs brown hair and eyes. Seeking a SF under 40 for a long term relationship. Ad# 482267

ALL MY HEART
Outgoing nice SBF 27 who enjoys basketball, classic cars and more. In search of a caring, sincere SBF 21-35. Ad# 482276

EASY TO TALK TO!
Single white male 45 62 209 lbs muscular, athletic, brown hair, blue eyes. Can out, get, give, have married, no dependents, outgoing personality, enjoys rollerblading, working out, etc. Seeking a friendly single female Wayne County. Ad# 404055

LIFE IS BETTER SHARED
White male dentist 6 173 lbs 54 very successful and attractive. Seeking white female 38 to 53 5'4 plus slim non smoker, very attractive and physically fit who loves fine dining, travel, cuddling and seeks a best friend. Ad# 403950

SPECIAL TIMES AHEAD
This quiet and easygoing SWM 40 is seeking an outgoing and humorous SWF 32-40 who shares similar interests with me such as sports, traveling and riding motorcycles. Ad# 481988

LOOKING FOR ME?
I am a SWM 28 59 with dark hair, eyes, outgoing and fun. I will be around. I like playing guitar, fishing and outdoor sports and am looking for an attractive and fun SWF 18-38. Ad# 481886

WHO ARE YOU INSIDE?
WWWM 48 510 200 lbs with brown hair/eyes and a mustache. I'm fun to be with and enjoy biking, live concerts and nature walks. I am in search of a SWF under 65 who is happy with herself and wants to share time together. Ad# 481479

TO HAVE AND HOLD
SWM 28 dark hair shy sensitive loves outdoors, long walks, shooting pool, fun activities. Seeking SWF enjoys skydiving, holding hands for companionship possible relationship. Ad# 481127

SEIZE THE DAY
Energetic SWM 45 510 170 lbs to outside life. Blue eyes with varied interests. Seeking talented fun SWF 38-40 who likes outdoors. Ad# 481086

EMPTY HOUSE
SWM 54 6 200 lbs loves keeping fit and eating healthy. Seeking SF under 63 who is gentle, loving, kind hearted, compassionate and pleasant. Ad# 480488

FIND OUT MORE
SWM 55 social drinker. Enjoys theater, fine dining, music, fishing, etc. Seeking a SWF who is fun, outgoing, and has a great sense of humor. Ad# 480488

THE PUB SHE ASSUMES
liability for the content of or replies to any advertisement or recording placed by the advertiser or any respondent. The advertiser and respondent agree to indemnify and hold the publisher and UltraMate, its employees and agents harmless from all costs, expenses, liabilities and damages resulting from or caused by this publication or recording placed by the advertiser or any respondent. The advertiser and respondent agree that they are at least 18 years old. Advertiser voice greetings will be rejected if they contain last names, phone numbers, any addresses, e-mail addresses or explicit sexual language. You should screen your responses carefully. First meetings should be held in a public place. The use of cordless or cellular phones is discouraged. Copyright UltraMate 08/19/03



Here's Bob.
He's looking for an attractive woman 30-40 years old.

Bob decides to call 1-800-487-2038 to respond to this ad.

While on the phone, Bob discovers 18 other women that match his search.

including:

3 Chatting Online

2 Chatting By Phone

Hey Bob! Press 2 to CHAT LIVE or leave a voice message for any of them right now!

Questions? Contact Customer Service - call 1-866-281-2976. Hours: Mon-Fri., 9a.m.-10p.m. EST or visit us online and click CONTACT US to send us an e-mail. Customer Service provided by DRMOC.

M Male B Black EI East Indian F-Female C Christian W White A Asian S Single WW Widowed N/S Non Smoker NA Native American H Hispanic

Filter

PURE ENTERTAINMENT!

HOT TICKET - 'A Streetcar Named Desire' puts some brute in ballet.

3

PURE PICKS - For the last time, there's a difference between New Wave and No Wave.

15

PARTY TIME - Swing over to the Fisher and party with the Fanclub to support arts education.

22

People's



the Lark



Blue Martini



Greektown Casino



Michael the bartender

Choice

FILTER JUDGED • ONE OF THE BEST ENTERTAINMENT SECTIONS IN THE COUNTRY BY SUBURBAN NEWSPAPERS OF AMERICA

Experience how it was

Jobim, Jobim, Jobim

de la Cruz, Antonio Carlos

revolutionized jazz.



Jazz at Lincoln Center's Afro-Latin Jazz Orchestra

Music of the Latin Jazz Masters

Arturo O'Farrill music director

Sat 3/27 8 pm

Hill Auditorium

03/

Peter Phillips director

Thu 8 pm

St Francis of Assisi Catholic Church

PROGRAM

Paestrina	Missa Papae Marcelli
Byrd	Tribulations civitatum
Josquin	Ave Maria
Josquin	Tu solus qui facis mirabilia
Sheppard	In manus tuas III
Fayfax	Agnus Dei from Missa Tecum principium

piano

Thu 8 pm

Hill Auditorium

PROGRAM

Schumann	Variations on the name Abegg for Piano in F Major Op 1 (1830)
Haydn	Piano Sonata in C Major Hob XVI/50 (1794-95)
Schubert	Fantasy in C Major D 760 ("Wanderer Fantasy") (1822)
Tan Dun	Eight Memories in Watercolor Op 1
Chopin	Nocturne in D flat Major Op 27 No 2 (1835)
Mozart/Liszt	Reminiscences of Don Giovanni S 418

Media Sponsors WGTB 91.3 FM and Observer & Eccentric Newspapers.
Forest Health Services presents the 125th Annual Choral Union on Ser es

A New Work by French cinema, circus,
and theater artist Philippe Decouflé

Performed by Lyon Opera Ballet

Yorgos Loukos artistic director

Fri 8 pm

Sat 8 pm

Power Center

One-Hour Family Performance

Sat 1 pm

Power Center

Individual performances are sponsored by

Funded in part by the National Endowment for the Arts

Media Sponsors Michigan Radio Michigan Television and Metro Times

The Herbert S. Amstel Fund presents the 4th Annual Theater Series

Thu 8 pm

Hill Auditorium

A special collaboration between UMS and the U M School of Music featuring 450 musicians including more than a dozen soloists from the classical, pop, folk, country, and operatic realms conducted by Leonard Slatkin

Funded in part by the University of Michigan UMS

Supported by the Maxine and Stuart Frankel Foundation and Linda and Maurice Binkow
Media Sponsors WGTB 91.3 FM and Observer & Eccentric Newspapers

Forest Health Services presents the 125th Annual Choral Union on Ser es

Event

Tartan Day celebrates all things Scottish

The Irish may dominate all things Celtic during March, home month to the St. Patrick's Day celebration, but the Scots are trying to make their mark in April by honoring the region's declaration of independence from England.

The St. Andrew's Society of Detroit is presenting a Tartan Day Celebration Ceilidh (pronounced kay-lee) on Saturday, April 3, at the Monaghan Knights of Columbus Hall in Livonia. "Next year we want a parade," said event co-organizer Franklin Dohanyos. "We've debated about a few places but we're not sure yet."

Innovations Scots have given the world include street lighting, pedal bikes, the locomotive, the bus, the thermos flask, telephones, television, color photographs and the kaleidoscope.

Organizers say the event is to celebrate Scottish heritage and the region's contributions to world culture.

It was actually April 6, 1320, when Scottish Independence Day was declared. It was only in 1991 that Canada, with its huge Scottish population, began celebrating that date as Tartan Day. America followed suit in 1998 when the U.S. Senate passed a resolution, also naming the date Tartan Day.

The first-ever Detroit Ceilidh evokes the spirit of the annual Highland Games at Greenmead in Livonia, only this event is held indoors. It features a traditional fish and chips buffet, Celtic fiddle music, bagpiping, and Highland dance demonstrations. There will be a cash bar.

TARTAN DAY

When: 6:30-11 p.m. Saturday, April 3

Where: Monaghan Knights of Columbus Hall, 19801 Farmington Road, Livonia

Admission: \$16 in advance seating limited to 300 people. Checks may be made out to St. Andrew's Society of Detroit and mailed to Tartan Day Celebration, 22106 Dorion, St. Clair Shores, 48082. Checks for tickets are due March 29. Mail-in tickets will be held at the door.

For information: Call (586) 293-4006

UNIVERSITY
MUSICAL SOCIETY
ums

www.ums.org

Outside the 734 area code call 800 221 1229



DE0819822

Index

- **BIG SCREEN** E4
New movies classic films cheap films cool rentals readers offer recommendations on where to get your flicks fix
- **BEYOND BAD** E5
Troll2 takes dreadfulness to a new level of artistry and that makes it a film to behold
- **DANCE** E9
Les Ballets Africains melds traditional African dance music and ritual with elements of western stage performance
- **COVER STORY** E10
You might want to take in a little entertainment and there's all kinds in metro Detroit See our People's Choice Awards for some premier places to play
- **TABLE HOPPING** E12
Want to know the best place to take a first date? Or the best restaurant to take your kids and still feel like you're an adult? See our People's Choice Awards for best food
- **DRINKOLOGY** E15
Exotic honey and spice characters topped off by vanilla and roasted hazelnut make Frapin VSOP cognac especially nice
- **BAR TIME** E15
Best bartender bar food wine by the glass see who readers picked
- **STAR STRUCK** E21
Find out what's in the stars for you this week Read your horoscope
- **CONTEST** E23
Miss Saigon ticket winners talk about their heroes

Filter

PURE ENTERTAINMENT!

Observer & Eccentric
NEWSPAPERS

- | | |
|--|---|
| Keely Kaleski
Editor | Megan Pennefather
Designer |
| Nicole Stafford
Staff Writer | Dan Dean
Design Editor |
| Lana Mini
Staff Writer | Susan Rosiek
Executive Editor |
| Stephanie Tardy
Staff Writer | Peter Neill
General Manager |

Cover design by Randall Masters

For editorial information please call (248) 901 2587
For advertising information please call (734) 953 2153



A HomeTown Communications Network publication

Hot Ticket



Brute ballet



North Carolina Dance Theatre brings 'A Streetcar Named Desire' with a twist

No doubt you've seen a chick flick, but what about a man ballet?

Sounds like an oxymoron. But *A Streetcar Named Desire*, a ballet based on Tennessee Williams' play, embraces the animalistic male energy so central to the original drama.

So, if you're dying to get your man to the ballet, mark off April 1-4 when North Carolina Dance Theatre performs the piece at the Detroit Opera House.

If you're going to drag him to the ballet, bring him to this," said Mark Diamond, who choreographed *A Streetcar Named Desire* three years ago for the dance company. "It's not going to be chiffon and tutus and men in tights. It's going to be hard-drinking men, and it's very athletic."

How else than through taxing athleticism could *Streetcar's* brutish, hardheaded lead character, Stanley — most famously portrayed by actor Marlon Brando in both the original Broadway production and the film version — translate into dance?

"Actually, he's so physical and so macho that he might have been the easier character to do," Diamond

STELLA!

What North Carolina Dance Theatre's ballet interpretation of Tennessee Williams' *A Streetcar Named Desire*

When 7:30 p.m. Thursday April 1, 8 p.m. Friday April 2 and Saturday April 3 and 2 p.m. Sunday April 4

Where: Detroit Opera House 1526 Broadway Detroit

Tickets: \$22, \$80, call (313) 237-SING or TicketMaster at (248) 645 6666. For more information, visit www.MichiganOpera.org

said, adding he repeatedly watched the film, directed by Elia Kazan, carefully studying the actors' physical movements.

In the end, Diamond drew on three dance styles. For Stanley, he looked to contemporary ballet and modern dance. For Blanche, the coy but aging Southern beauty who is the sister of Stanley's wife, the more lyrical language of classical ballet.

That is until Blanche starts to go crazy, he said. "Then she becomes more modern."

Music and lighting reinforces the differences between the lead male and female characters.

While Stanley moves to jazz, Dixieland, trains, thunder, rain and the streetcar, Blanche comes alive to Chopin.

While choreography and stage choices revolve around the play's character contrast, the ballet works on several levels. It envelops the audience in a sensory experience, unfolds the plot and probes the story's affective content.

"This is a story that has everything. It has flawed characters. It has violence. It has love," said Diamond. "With dance, it's not always verbatim, it's the message of the play, it's the emotion of the play."



Big screen

Sit back, enjoy a movie out or at home

New movies, classic films, cheap films, cool rentals - our readers offer their recommendations on where to get your flicks fix

BEST PLACE TO WATCH A MOVIE

- Uptown Palladium 12
Flanked by Buca DiBeppo and Tower

Records, this downtown Birmingham theater boasts state-of-the-art projection and sound equipment special high-back seats with custom Tempur-Pedic cushions, wall-to-wall curved screens, stadium seating and a giant two-story mural in the lobby

- Runners up AMC 20, Star Southfield

BEST CHEAP FLICKS

- Farmington Civic Theater

Recent-run movies including *The Last Samurai* and *Dr. Seuss' The Cat in the Hat* are only \$3 a ticket at this 1940 Art Moderne theater with the upright green and red neon sign, which seats 410 on two levels

The elegant facade designed by C Howard Crane features shades of red and off-white, and recalls the charm of Hollywood's glory days. Now operated by the city of Farmington, the Civic is one of the few old-fashioned movie houses still in operation in metro Detroit

- Runners up Cinema Universal Mall, Penn Theater



The Farmington Civic Theater was voted best place to see a cheap flick

BEST PLACE TO RENT A MOVIE/DVD

- Blockbuster Video

That blue and yellow torn movie ticket logo flies high over many a strip mall, beckoning pop culture vultures to the nation's leading renter of DVDs with hundreds on display in each store

Blockbuster still stocks VHS movies for the dinosaurs among us, along with movie snacks, new and used movies for sale, a range of movie, music and culture magazines and even Direct TV pay-per-view movie packages

The stores are clean and staff are typically prompt and helpful. It's all working, the company's sales are predicted to reach \$30 billion 2006

- Runners up Family Video, Hollywood Video

"ZOINKS, THIS MOVIE IS AWESOME!"
- Mark S. Allen, UPN-TV

SCOOPY-DOO 2
MONSTERS UNLEASHED

A MOSAIC MEDIA GROUP PRODUCTION A RAJA GOSNELL FILM "SCOOPY-DOO 2: MONSTERS UNLEASHED" FREDDIE PRINZE JR. SARAH MICHELLE GELLAR MATTHEW LILLARD LINDA CARDELLINI SETH GREEN PETER BOYLE TIM BLAKE NELSON AND ALICIA SILVERSTONE MUSIC BY DAVID NEWMAN EXECUTIVE PRODUCERS BRENT O'CONNOR KELLEY SMITH-WAIT JOSEPH BARBERA BASED ON CHARACTERS CREATED BY HANNA BARBERA PRODUCTIONS WRITTEN BY JAMES GUNN PRODUCED BY CHARLES ROVEN RICHARD SUCKLE DIRECTED BY RAJA GOSNELL

PG PARENTAL GUIDANCE SUGGESTED
SOME MATERIAL MAY NOT BE SUITABLE FOR CHILDREN
Some Scary Action Rude Humor And Language

AMC FORUM 30	STARTS TOMORROW!	AMC LIVONIA 20
BEACON EAST	BIRMINGHAM PALLADIUM	CANTON 6
MJR SOUTHGATE 20	NOVI TOWN CTR. 8	PHOENIX AT BEL AIR CTR.
PHOENIX WEST RIVER	SHOWCASE DEARBORN	SHOWCASE STERLING HTS.
SHOWCASE WESTLAND	STAR FAIRLANE 21	STAR GRATIOT
STAR GREAT LAKES CROSSING	STAR JOHN R	STAR ROCHESTER
STAR SOUTHFIELD	STAR TAYLOR	UA COMMERCE STADIUM

CALL THEATRES FOR SHOWTIMES
NO PASSES OR DISCOUNT COUPONS ACCEPTED

For More Information About This Movie
America Online Keyword: Scooby Doo 2 www.scoobydoe2movie.com Moviefone.com

MOVIES

- Uptown Palladium 12, 250 N Old Woodward Birmingham (248) 644-FILM
- AMC 20 19500 Haggerty Road Livonia (734) 542 9909
- Star Theatres-Southfield, 25333 W 12 Mile (248) 372 2222

CHEAP FLICKS

- Farmington Civic Theater 33332 Grand River Ave Farmington, (248) 474 1951
- Cinema Universal Mall 28582 Dequindre Warren (586) 751 3161
- Penn Theater 760 Penniman Plymouth (734) 453-0870

MOVIE/DVD RENTALS

- Blockbuster Video locations throughout metro Detroit visit www.blockbuster.com to find one near you
- Family Video, several locations throughout southeast Michigan including 146 Venoy Road Westland (734) 326 6112, go to www.famvid.com for more store locations
- Hollywood Video several metro Detroit locations visit www.hollywoodvideo.com

Small screen

'Troll2' sinks to new levels of greatness

Why? Why make a sequel to a basically lousy movie? I don't know, yet here we are, flooded by sequels. There are enough *Children of the Corn* to fill a field *Leprechaun* keeps coming back, and the *Puppet Master* series is up to about 600 by now

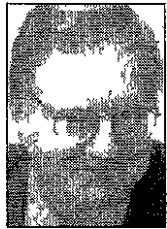

Beyond Bad

Greg Kowalski

manages to rise above the crowd in its sheer awfulness. There is virtually nothing good about this movie.

IT STINKS

The story stinks. The effects are bad and even the acting is horrible. Usually

even the worst of the worst movies have decent acting. I think that's because there are a lot of pretty good actors and very few places for them to act so they will appear in anything.

Too bad none of them were available for this mess. I've seen high school plays with better acting.

The story has nothing to do with the original *Troll*, which was about an evil gnome that possessed a little girl. Here we have a little boy who is obsessed with his dead grandfather who keeps reappearing. Dead grandpa plays a key role as the boy and his family — mom, dad and older sis — head out West for a family vacation at a town called Nilbog, which has absolutely nothing of interest to offer.

Nilbog — that's Gobln spelled backward. Get it? That's about as clever as things get here.

Turns out Nilbog is inhabited by — gasp — goblins. They look like us except when they show their true forms, or rather put on their awful rubber masks.

For some curious reason they are all vegetarians and want everyone to eat green doughnuts. I don't know why. There also is a queen goblin that turns people into trees. The one inspired scene shows a man turned literally into a potted plant.

But everything else is awful. So why plunk down \$4 for a DVD rental?

Because this is awe-inspiringly bad. It transcends ineptitude. It takes dreadful ness to a new level of artistry and that, in a perverted way, makes it a film to behold. P.S. I haven't seen the new Stephen King production *Kingdom Hospital*, but I hope he hasn't so blatantly stolen *The*

Kingdom, a fine Dutch-made-for-TV film about — guess what — a haunted hospital.

Greg Kowalski has seen every sequel to *Friday* the 13th and hated every one. He can be reached at (248) 901-2570 or by e-mail at gkowalski@oe.homecomm.net.

“HILARIOUS!
An Early Contender For
Best Picture Of The Year!”
Jim Svejda, KNX/CBS RADIO

“It’s the funniest film in years!”
Dean Richards, WGN-TV/CHICAGO

“Riotously funny!” **“A laugh-out-loud movie!”**
Joyce Kulhawik, HOT TICKET Leonard Maltin, HOT TICKET

TOM HANKS
THE LADYKILLERS

TOUCHSTONE PICTURES PRESENTS A TOM JACOBSON PRODUCTION TOM HANKS "THE LADYKILLERS" ERMA P HALL MARLON WAYANS J.K. SIMMONS TZITZA RYAN HURST
CASTING BY ELLEN CHENOWETH EXECUTIVE MUSIC BY BONE BURNETT MUSIC BY CARTER BURWELL FILM EDITOR RODRICK JAYNES DIRECTOR OF PHOTOGRAPHY ROGER DEAKINS A.S.C. B.S.C.
PRODUCED BY ETHAN COEN & JOEL COEN TOM JACOBSON BARRY SONNENFELD AND BARRY JOSEPHSON WRITTEN FOR THE SCREEN AND DIRECTED BY JOEL COEN & ETHAN COEN

R RESTRICTED
UNDER 17 REQUIRES ACCOMPANYING PARENT OR ADULT GUARDIAN
LANGUAGE, INCLUDING SEXUAL REFERENCES

Touchstone Pictures
SOUNDTRACK BY NAPPY ROOTS
A LAB E ON
SOUNDTRACK BY NAPPY ROOTS
SOUNDTRACK BY NAPPY ROOTS

ladykillers.movies.com
Soundtrack Includes The New Single Trouble Of This World (Coming Home) Performed By NAPPY ROOTS

STARTS FRIDAY	AMC FORUM 30	AMC LIVONIA 20
BIRMINGHAM 8	EMAGINE NOVI	MJR SOUTHGATE 20
PHOENIX AT DEL AIR CENTRE	SHOWCASE DEARBORN	SHOWCASE STERLING HEIGHTS
STAR FAIRLANE	STAR GRATIOT AT 15 MI.	STAR GREAT LAKES CROSSING
STAR JOHN R AT 14 MILE	STAR SOUTHFIELD	UA COMMERCE STADIUM 14

NO PASSES OR DISCOUNT COUPONS ACCEPTED

OE08198422

Rent a movie tonight

Looking for some movie suggestions? Here are some from Hollywood Video. Visit them online at www.hollywood-video.com.

■ *Dying Young* (1991) — Stars Julia Roberts and Campbell Scott. Directed by Joel Schumacher. Tearful love story about a young nurse who, to get over a cheating boyfriend, takes a job as a care-taker for a terminal cancer patient. The two slowly fall in love, each teaching the other something about life and death. Runs 111 minutes. Rated R.

■ *Dr. Seuss' The Cat in the Hat* (2003) — Stars Mike Myers and Dakota Fanning. Directed by Bo Welch. Live-action adaptation of Dr. Seuss' famous literary classic about a mischievous feline visiting two bored children. Runs 82 minutes. Rated PG for mild crude humor and some double-entendres.

■ *Ghost* (1990) — Stars Patrick Swayze and Demi Moore. Directed by Jerry Zucker. Before a young potter's boyfriend can say the words "I love you," he's killed by an intruder. But there's more to the story than meets the eye, of course, and before long the ghost of the dead guy is jumping through walls and frightening cats as a way to get the attention of his girlfriend — he really does love her, by the way — so that she can get off her potter's wheel and solve the mystery of his murder. Runs 128 minutes. Rated PG-13.

■ *Leaving Las Vegas* (1995) — Stars Nicolas Cage and Elisabeth Shue. Directed by Mike Figgis. A raging alcoholic decides to move to Las Vegas in order to drink himself to death. Once there, he meets up with a beautiful but pathetic prostitute who falls in love with him and tries to save him from ruin. Runs 111 minutes. Rated R.

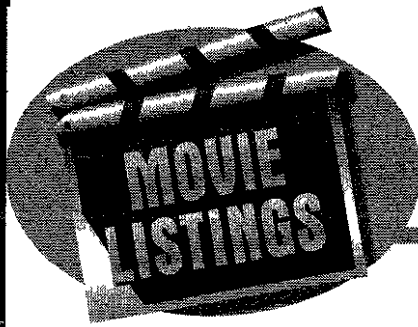

THE
Observer & Eccentric
NEWSPAPERS
Theatre Guide

**Where available by deadline,
features and times are listed.**

**Call your local theatre for showings for this
week. Check listings below for phone numbers
and websites.**

**National Amusements
Showcase Cinemas
Showcase Dearborn 1 8**
Michigan & Telegraph
313 561 3449
Bargain Matinees Daily All Shows until 6 pm
*Late Shows Fri Sat

Showcase Westland 1-8
6800 Wayne Rd
One blk S of Warren Rd
734-729 1060
Bargain Matinees Daily
All Shows Until 6 pm • Late Shows Fri Sat

Star Theatres
The World's Best Theatres
Bargain Matinees Daily \$5 75 All Shows
Starting before 6:00 pm • Now accepting Visa
& MasterCard
NO CHILDREN UNDER THE AGE OF 6 WILL BE ALLOWED
IN PG 13 & R RATED FILMS AFTER 6 PM YOU MUST BE
AT LEAST 17 YEARS OF AGE WITH PROPER
IDENTIFICATION TO PURCHASE A TICKET FOR A RATED R
FILM ONLY ONE TICKET PER ID WILL BE GIVEN NP
DENOTES NO VIP TICKETS

Star Great Lakes Crossing
Great Lakes Shopping Center
248 454 0366

Star John R at 14 Mile
32289 John R Road
248-585 2070
On line at www.fandango.com

Star Rochester Hills
200 Barclay Circle
248 853 2260
STUDENT DISCOUNT NOW AVAILABLE WITH VALID
SCHOOL ID

Star Southfield
12 Mile between Telegraph &
Northwestern off I 696
248 353 STAR
FOR SHOWTIMES AND TO PURCHASE TICKETS
BY PHONE CALL 248-372-2222
www.STAR-SOUTHFIELD.com
NP FEATURES SORRY NO VIP DISCOUNT
TICKETS ACCEPTED SUNDAY TUESDAY

Saturday Night is Family Night at Star Southfield
Star Theatres is committed to providing the best
environment for family entertainment and to
encourage families to get out to a movie STAR
SOUTHFIELD will provide a FREE SMALL POP and
POPCORN to all kids 16 and under if accompanied
by a parent to all shows after 8 30 pm During
our Family Saturdays no minors 16 Years and
under will be permitted entry unless with a parent
after 8 30 pm so grab Mom and Dad and HEAD
FOR THE MOVIES! PLEASE ONLY ONE TICKET PER ID
FOR RATED R FILMS

United Artists Commerce-14
3330 Springvale Drive
Adjacent to Home Depot
North of the intersection of 14 Mile & Haggerty
248 960 5801
Bargain Matinees Daily for all Shows
Starting before 6 pm
Same Day Advance Tickets Available
WWW.UAT

Birmingham 8
Uptown Birmingham 8
211 S Woodward
Downtown Birmingham
248-644 FILM
www.uptownbirmingham8.com
MATINEE MOVIES \$6 00
Classic Film Series Every Wednesday

Eternal Sunshine of the Spotless Mind (R)
Fri 7 40 4 05 6 40 9 10 12 00
Sat 11 15 1 40 4 05 6 40 9 10 12 00
Sun Wed 11 15 1 40 4 05 6 40 9 10
Thur 11 15 1 40 4 05 6 40 9 10
Spartan (R)
Fri Sat 11 45 2 05 4 30 7 05 9 25 12 00
Sun Wed 11 45 2 05 4 30 7 05 9 25
Miracle (PG)
Fri Sat 10 40 3 05 6 25 9 15
Sun Wed 12 10 2 05 6 25 9 15
Thur 1 45 2 05 4 30 7 05 9 25
Twisted (R)
Fri Sat 11 30 1 45 4 00 7 10 9 40 12 00
Sun Wed 11 30 1 45 4 00 7 10 9 40
Thur 11 30 1 45 4 00 7 10 9 40
Triplets of Belleville (PG-13)
Fri Sat 11 35 1 35 3 35 6 30 8 30 10 30
Sun Wed 11 35 1 35 3 35 6 30 8 30
Thur 11 35 1 35 3 35 6 30 8 30
Mystic River (R)
Fr Wed 12 00 2 50 6 00 9 00
In America (PG-13)
Fri Sun Wed 11 00 1 25 3 50 6 50 9 30
Sat 11 00 1 25 3 50 6 50 9 30 12 00
Thur 11 00 1 25 3 50 6 50 9 30
Fifty First Dates (PG-13)
Fri Sat 11 40 2 00 4 10 7 15 9 45 12 00
Sun Wed 11 40 2 00 4 10 7 15 9 45
Thur 11 40 2 00 4 10 7 15

Birmingham Palladium 12
Uptown Palladium 12
250 North Old Woodward Ave
Downtown Birmingham
248 644-FILM
www.uptownpalladium12.com
Featuring 12 stadium seating and tonoms with state of
the-art wall to wall curved screens Do by Dig tal surround
sound two grant concess on stands valet parking Little
Caesar's Pizza Ray's Ice Cream and the all new Prem ere
Entertainment Auditorium
MATINEE MOVIES \$6.00
CHECK OUT OUR MIDNIGHT MOVIES!

MJR Theatres
**MJR Brighton Towne Square-
Cinema 16**
8200 Murphy Drive
Brighton Towne Square
behind Home Depot
CALL (810) 77 FILMS #548
Student Price \$5 75 with ID • 16 Screen State of
the Art Cinema • All Stadium Seating • All Big
Screens • All Digital Sound

(NP) DAWN OF THE DEAD [R]
12 15 2 45 (5 15 @ \$5 00) 7 40 10 00
THE PASSION OF THE CHRIST [R]
1 00 2 00 (4 00 5 00 @ \$5 00) 7 00 8 00 9 50
(NP) ETERNAL SUNSHINE OF THE SPOTLESS
MIND [R]
1 10 (4 10 @ \$5 00) 7 10 9 45
(NP) TAKING LIVES [R]
1 30 (4 40 @ \$5 00) 7 20 9 55
(NP) SECRET WINDOW [PG13]
12 10 1 30 2 30 (4 20 5 00 @ \$5 00) 6 45 7 40 9 10 10 00
(NP) AGENT CODY BANKS: DESTINATION
LONDON
[PG] 12 00 1 00 2 20 3 20 (4 40 5 40 @ \$5 00) 7 00 9 20
STARSKY & HUTCH [PG13]
12 00 1 15 2 30 (4 20 5 20 @ \$5 00) 6 50 7 45 9 20 10 00
HIDALGO [PG13]
12 50 (4 15 @ \$5 00) 7 15 9 55
TWISTED [R]
1 20 (4 15 @ \$5 00) 7 10 9 40
CONFESSIONS OF A TEENAGE DRAMA QUEEN
[PG]
12 15 2 30 (4 50 @ \$5 00) 7 20 9 30 **
no 7 20 Saturday
50 FIRST DATES [PG13]

12 10 2 40 (5 15 @ \$5 00) 7 45 10 00
MIRACLE [PG]
12 30 (4 00 @ \$5 00) 6 50 9 50
LORD OF THE RINGS: RETURN OF THE KING
[PG13] 8 00

FREE kid Shows Saturday and Sunday
For kids 12 & under adults \$1 00
SPY KIDS 3-D [PG] 10 00 12 00

SNEAK PREVIEW Saturday
(NP) GIRL NEXT DOOR [R] 7 20

**MJR Waterford
Cinema 16**
7501 Highland Rd
S E corner M 59 & Williams Lake Rd
24 hour Movie Line
248-666-7900
CALL 77 FILMS #551
Free Refill on Popcorn and Pop
Visa & Mastercard Accepted

(NP) DAWN OF THE DEAD [R]
12 15 1 40 2 40 (4 10 5 10 @ \$5 00) 6 45 7 40 9 15
10 00

THE PASSION OF THE CHRIST [R]
1 00 2 00 (4 00 5 00 @ \$5 00) 7 00 8 00 9 50
(NP) ETERNAL SUNSHINE OF THE SPOTLESS
MIND [R]

1 10 (4 10 @ \$5 00) 7 00 9 30
(NP) TAKING LIVES [R]
1 20 (4 45 @ \$5 00) 7 30 9 55

(NP) SECRET WINDOW [PG13]
12 10 1 30 2 30 (4 20 5 00 @ \$5 00) 6 45 7 40 9 10
10 00

(NP) AGENT CODY BANKS: DESTINATION
LONDON
[PG] 12 00 1 00 2 20 3 20 (4 40 5 40 @ \$5 00) 7 50
9 50

(NP) SPARTAN [R] 1 20 (4 30 @ \$5 00) 7 20 9 45
STARSKY & HUTCH [PG13]
12 00 1 15 2 30 (4 20 5 20 @ \$5 00) 6 50 7 45 9 20
10 00

HIDALGO [PG13]
12 50 (4 15 @ \$5 00) 7 15 9 55
CONFESSIONS OF A TEENAGE DRAMA QUEEN
[PG]

12 15 2 30 (4 50 @ \$5 00)
50 FIRST DATES [PG13]
12 10 2 40 (5 15 @ \$5 00) 7 45 10 00 **
MIRACLE [PG] 6 50 9 50

LORD OF THE RINGS: RETURN OF THE KING
[PG13] 8.00

FREE kid Shows Sat & Sun
For kids 12 & under adults \$1 00
SPY KIDS 3 D [PG]
[PG] 10 00 12 00

SNEAK PREVIEW Saturday
(NP) GIRL NEXT DOOR [R] 7 40

Main Art Theatre III
118 Main at 11 Mile
Royal Oak
248 542 0180
call 77 FILMS ext 542
(DISCOUNTED SHOWS!)*
TICKETS AVAILABLE AT BOX OFFICE
OR PHONE 248-542-0180
VISA AND MASTERCARD ACCEPTED

Maple Art Theatre III
4135 W Maple West of Telegraph
Bloomfield Hills
248 542 0180
(DISCOUNTED SHOWS!)*
SUNDAY THROUGH THURSDAY

Oxford 7 Cinemas, L.L.C.
Downtown Oxford
Lapeer Rd (M 24)
(248) 628-7101
Fax (248) 628-130

State Wayne Theatre
35310 Michigan Ave Wayne
734-326-4600
THURSDAY ALL SEATS 99¢
CLOSED MONDAY THRU WEDNESDAY
CALL THEATRE FOR SHOWTIMES

THE PERFECT SCORE [PG13]
TORQUE [PG13]
SOMETHING'S GOTTA GIVE [PG13]
CHEAPER BY THE DOZEN [PG]
THE LAST SAMURAI [R]
HAUNTED MANSION [PG]
GOTHIKA [R]
CAT IN THE HAT [PG]

Michigan Theater
603 E Liberty Ann Arbor
(734) 668 7000
(734) 668 TIME
\$8 00 Adult \$6 25 Students, Seniors and
children under 12 \$5 50 Michigan Theater
Members

Ford Wyoming Drive-In
Dearborn
(313) 846-6910

OPEN 6 30 PM
FREE IN CAR ELECTRIC HEATER

THE PASSION OF THE CHRIST [R]
MY BABY'S DADDY [PG13]

TWISTED [R]
BARBERSHOP 2: BACK IN BUSINESS [PG13]

TAKING LIVES [R]
STARSKY & HUTCH [PG13]

DAWN OF THE DEAD [R]
TEXAS CHAINSAW MASSACRE [R]

SECRET WINDOW [PG13]
YOU GOT SERVED [PG13]

[6-9]
CLOSED FOR THE SEASON

Madstone Ann Arbor
462 Briarwood Circle
734-984-1000

Farmington Civic Theatre
33332 Grand River Farmington
248-474-1951
BARGAIN PRICES DAILY
CALL THEATRE FOR SHOWTIMES

CHEAPER BY THE DOZEN [PG]
SOMETHING'S GOTTA GIVE [PG1]

Cinemark Movie 16
The Best Seat in Town
28600 Dequindre Rd Warren MI
810 558 8207
MONDAY THRU FRIDAY
FIRST SHOW OF THE DAY 50¢
ALL SHOWS \$1 50 EXCEPT FRIDAY AND
SATURDAY AFTER 6 00 PM ALL SEATS \$2 00
BARGAIN TUESDAY
ALL SHOWS AFTER THE FIRST SHOW \$1 00

State
233 State St at Liberty Ann Arbor
734-761 8667
\$8 00 Regular Adult \$6 25 Students, Seniors and
children under 12, \$5 00 all shows beginning
before 6 pm \$5 50 Michigan Theater Member

Imagine
Located in Fountain Walk
on the south side of 12 Mile Road
1/4 Mile west of Novi Road
248 319-3456
Discover the Magic of Movies
and More at Imagine
Box Office opens at 11 45
GIFT CERTIFICATES ON SALE NOW!
*DENOTES LUXURY SEATING AVAILABLE
STUDENT DISCOUNT NOW AVAILABLE
www.imagine-entertainment.com
18 ALL STADIUM AUDITORIUMS • DIGITAL SOUND
BEER, WINE & COCKTAILS
Box Office Opens at 11 30 am

Log onto website at www.strangeheart.com
for more information

IMAGINE THAT!

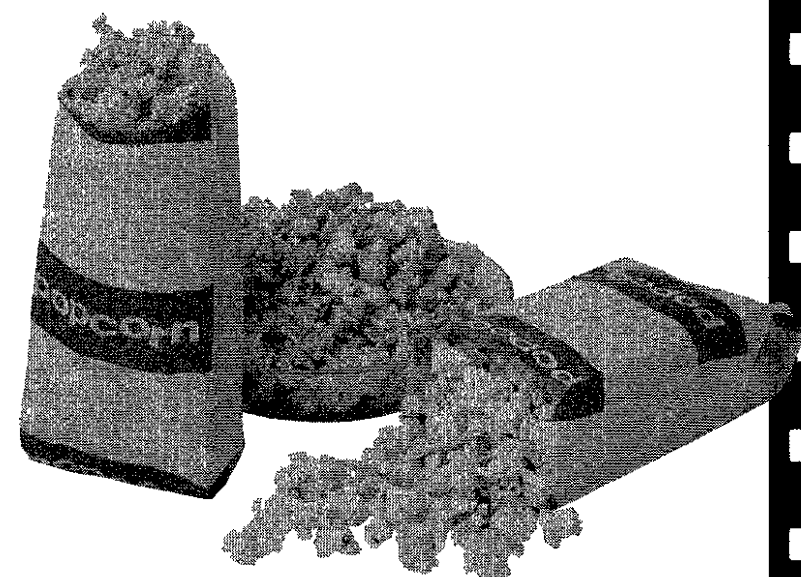

More movies

Gore galore in creepy 'Dawn of the Dead'

BY DAVID GERMAIN
ASSOCIATED PRESS

Dawn of the Dead has seen better days

The high octane update of the 1979 zombie fest offers gore galore, some truly creepy images, occasionally wicked humor and impressive performances for a genre where acting usually is secondary

Beyond its strong cast, though, the new *Dawn* lacks the bite of George Romero's original, a low budget affair that served up real drama and sharp satire of American consumer culture as side dishes to its victims entrails

Director Zack Snyder's *Dawn of the Dead* mainly is a run-of-the-mill action flick packed with loud gunfire and louder explosions. The movie piles on a bigger group of central characters than the original so the filmmakers have more real people to zombie-fy, but you end up knowing and caring less about each person

The presence of Ving Rhames, Mekhi Phifer and especially Sarah Polley elevates expectations. If an indie-film queen such as Polley would choose *Dawn of the Dead* as her first action gambit, it must be something special, right?

Wrong While Polley and her co-stars are in on the zombie gag wholeheartedly, their earnest performances never quite lift *Dawn of the Dead* to fresh horror heights

Polley's Ana, a nurse who lives in a tranquil Wisconsin housing tract, awakens one morning to find the world in chaos from a plague of flesh-munching zombies, whose victims inevitably die then return as living ghouls themselves

Ana hooks up with a group of survivors — somber policeman Kenneth (Rhames), street hood Andre (Phifer) and his wife, salesman Michael (Jake Weber)

FAST ZOMBIES

Unlike Romero's eerily lumbering monsters, which his heroes could sidestep and outrun, Snyder's zombies are fast, with the ferocity of rabid dogs. Nimble zombies would be a decent innovation to this horror subgenre if it had not already been done better and scarier in last year's *28 Days Later*

Screenwriter James Gunn offers a few darkly amusing sequences, including a shooting gallery in which survivors on rooftops single out zombies that resemble celebrities — Jay Leno, Burt Reynolds, Rosie O'Donnell — to blow away

The humor becomes so wisecracking that it undermines the horror. Even with a big budget and improved zombie makeup, the remake simply is not that frightening, especially compared to the chills of Romero's version, itself a follow-up to the 1968 classic *Night of the Living Dead*

Dawn of the Dead a Universal release runs 102 minutes. Two stars out of four



MICHAEL GIBSON

Sarah Polley as Ana and Ving Rhames as Kenneth in the zombie action thriller 'Dawn of the Dead'

"TWO THUMBS WAY UP!
A GREAT EPIC FILM."

—Ebert & Roeper

"POWERFULLY MOVING!"

—Peter Travers, ROLLING STONE

"AN IMPRESSIVE, PASSIONATE VISION!"

—Michael Wilmington, CHICAGO TRIBUNE



—Roger Ebert, CHICAGO SUN-TIMES

MEL GIBSON
FILM

THE
PASSION
OF THE CHRIST
JIM CAVIEZEL

ICON PRODUCTIONS PRESENTS AN ASSOCIATION WITH NEWMARKET FILMS AN ICON PRODUCTION A MEL GIBSON FILM JIM CAVIEZEL "THE PASSION OF THE CHRIST"

MONICA BELLUCI MARIA MORTENSTERN SERGIO RUBINI SARALA BISHOP JOHN EDNEY MAURIZIO MILELLIOTTI JOHN WRIGHT FRANCESCO FRIGERI
GALLO DESSAUNEL EMILIO SISTI MEL GIBSON BRUCE DAVEY STEPHEN MACEVEETY BENEDICT FITZGERALD MEL GIBSON MEL GIBSON

R RESTRICTED
UNDER 17 REQUIRES ACCOMPANYING PARENT OR ADULT GUARDIAN
For Sequences of Graphic Violence

Read the book by
TYNDALE PUBLISHING
Soundtrack available on
SONY MUSIC / INTEGRITY

NEWMARKET FILMS
ICON
THE PASSION Soundtrack CD, keepsake of the movie, NOW AVAILABLE in stores.

www.thepassionofthechrist.com

NOW SHOWING AT THESE THEATRES			AMC FORUM 30
AMC LAUREL PARK	AMC LIVONIA 20	BEACON EAST	BIRMINGHAM PALLADIUM
CANTON 6	EMAGINE NOVI	MJR SOUTHGATE 20	PHOENIX AT BEL AIR CTR
PHOENIX WEST RIVER	SHOWCASE DEARBORN	SHOWCASE STERLING HTS.	SHOWCASE WESTLAND
STAR FAIRLANE 21	STAR GRATIOT	STAR GREAT LAKES	STAR JOHN R
STAR ROCHESTER	STAR SOUTHFIELD	STAR TAYLOR	UA COMMERCE STADIUM

"YOU'LL BE GUESSING ALL THE WAY 'TIL THE END, AND YOU'LL STILL BE WRONG."

—Greg Russell, WDWB-TV

"A MUST-SEE!"

The best thriller I've seen in ages."

—Bill Zwecker, CHICAGO SUN-TIMES

"TWO THUMBS UP!"

—Ebert & Roeper

"The best film of its type since 'The Silence of the Lambs'."

—Neil Rosen, NY 1

TAKING LIVES

www.takinglives.com

America Online Keyword: Taking Lives



AMC FORUM 30	AMC LAUREL PARK	AMC LIVONIA 20
BIRMINGHAM PALLADIUM	EMAGINE NOVI	MJR SOUTHGATE 20
PHOENIX AT BEL AIR CTR.	SHOWCASE DEARBORN	SHOWCASE STERLING HTS.
SHOWCASE WESTLAND	STAR FAIRLANE 21	STAR GRATIOT
STAR GREAT LAKES	STAR JOHN R	STAR ROCHESTER
STAR SOUTHFIELD	STAR TAYLOR	UA COMMERCE STADIUM

CHECK MOVIE GUIDE OR CALL THEATRES FOR SHOWTIMES NO PASSES OR DISCOUNT COUPONS ACCEPTED

More movies

'Taking Lives' musters twitch-in-your-seat scares

BY DAVID GERMAIN
ASSOCIATED PRESS

Angelina Jolie finally has a decent movie on her hands, and the dark, suspenseful thriller *Taking Lives* comes none too soon.

Since winning the supporting actress Academy Award for 1999's *Girl Interrupted*, Jolie has starred in a string of bad movies although she has managed to maintain a

strong screen presence in the service of rotten films such as *Original Sin*, *Beyond Borders*, *Life Or Something Like It* and her two *Lara Croft Tomb Raider* outings.

With *Taking Lives*, Jolie gives her finest performance since her Oscar win and is surrounded by a robust supporting cast in a fairly fresh serial killer tale.

Co-star Ethan Hawke, an Oscar nominee for *Training Day*, continues to emerge as a

serious actor with far greater range than earlier boyish roles hinted at.

Taking Lives is based on the novel by Michael Pye, though oddly, Jolie's lead character was created specifically for the film and grafted onto the tale of a mass-murderer who steals his victims' identities. Director D.J. Caruso, screenwriter Jon Bokenkamp and their collaborators developed the character of FBI profiler Ileana Scott.

Her intuitive approach, which includes

laying in a suspect's boyhood cot or a victim's makeshift grave to grasp their perspective, uncovers a 20-year chain of unsolved killings that indicate the perpetrator has been targeting loners and assuming their identities because of inadequacies in his own life.

Her own hard emotional shell softens when she encounters art dealer James Costa (Hawke), a witness to one of the killings who later becomes a suspect and potential victim, along with a romantic interest for the dispassionate Scott.

TWISTS AND SURPRISES

Jolie's sultry stoniness and Hawke's puppy-dog earnestness mingle well, and the film's twists and surprises give the leads a chance to play out deep, dark passions with convincing sentiment.

Gena Rowlands highlights the supporting cast, making a small role as a suspect's mother her own with a queen-bee arrogance that offers hints of what Norman Bates' mom might have been like before he killed her and started wearing her clothes.

Taking Lives, a Warner Bros. release, runs 103 minutes. Three stars out of four.



This Fairy Tale
Is About
To Get Real.

Julia Stiles
The Prince & Me

You're Invited To
A Special Sneak Preview
Saturday, March 27
& Sunday, March 28

Soundtrack Album
Features The Hit
'EVERYBODY WANTS YOU'
By JOSH KELLEY

PARAMOUNT PICTURES PRESENTS IN ASSOCIATION WITH LIONS GATE ENTERTAINMENT
A SOBINI FILMS PRODUCTION A MARTHA COOLIDGE FILM JULIA STILES "THE PRINCE & ME" LUKE MARLEY BEN MILLER
JAMES FOX AND MIRANDA RICHARDSON CASTING BY HOPKINS SMITH BARDEN & BENNETT MUSIC BY JENNIE MUSKETT
MUSIC SUPERVISOR ROBIN URDANG PRODUCER JEFFREY LAMPERT EXECUTIVE PRODUCERS CAMI WINKOFF BOB SCHINDLER PRODUCED BY MARK AMIN
STORY BY MARK AMIN AND KATHERINE FUGATE SCREENPLAY BY JACK AMIEL & MICHAEL DEGLER AND KATHERINE FUGATE
DIRECTED BY MARTHA COOLIDGE

PG PARENTAL GUIDANCE SUGGESTED
SOME MATERIAL MAY NOT BE SUITABLE FOR CHILDREN
SOME SEX RELATED MATERIAL & LANGUAGE
For rating reasons go to www.filmratings.com

SOUNDTRACK ALBUM ON HOLLYWOOD RECORDS
princeandme.com

SPECIAL SNEAK PREVIEW THIS WEEKEND			AMC FORUM 30
AMC LIVONIA 20	BIRMINGHAM PALLADIUM	MJR SOUTHGATE 20	
SHOWCASE STERLING HTS.	STAR FAIRLANE 21	STAR GRATIOT	
STAR GREAT LAKES CROSSING	STAR JOHN R	UA COMMERCE STADIUM	

MADSTONE THEATERS PRESENTS
THE PREMIER PIC SERIES
SIX TITLES. SIX WEEKS. • MARCH 19 - APRIL 29

"ROMANCE, BETRAYAL...
a superb post-Soviet
Godfather movie."
Jack Matthews, NY DAILY NEWS

TYCOON
A NEW RUSSIAN

STARTS FRIDAY, MARCH 26 • ONE WEEK ONLY!

MADSTONE THEATERS 1 00 4 00
BRIARWOOD MALL ANN ARBOR 7 00 9 35
(734) 994 1000
www.madstonetheaters.com/premierpic

0E08109420

ENTERTAINMENT WEEKLY
"Dawn Of The Dead' Is Smashing. Grade: A
The best re-envisioning of a horror classic in memory."
Lisa Schwarzbaum

DAWN OF THE DEAD

STRIKE R

© 2004 UNIVERSAL STUDIOS

NOW SHOWING AT THESE THEATRES

AMC LAUREL PARK 734.462.8200	AMC LIVONIA 20 734.542.9900	BEACON EAST 313.882.7800	AMC FORUM 30 810.254.1381
CANTON 6 734.981.1900	MJR SOUTHGATE 20 734.284.3496	NOVI TOWN CTR. 8 248.465.7469	BIRMINGHAM PALLADIUM 248.644.FILM
PHOENIX WEST RIVER 248.785.6572	SHOWCASE DEARBORN 313.561.3449	SHOWCASE STERLING HTS 810.979.3160	PHOENIX AT BEL AIR CTR 313.438.3494
STAR FAIRLANE 21 313.982.0015	STAR GRATIOT 810.791.2420	STAR GREAT LAKES 248.464.0368	SHOWCASE WESTLAND 734.729.1060
STAR ROCHESTER 248.893.2280	STAR SOUTHFIELD 248.372.2222	STAR TAYLOR 313.287.2200	STAR JOHN R 248.585.2070
			UA COMMERCE 248.960.5801

CHECK MOVIE GUIDE OR CALL THEATRES FOR SHOWTIMES AND SOUND INFORMATION SPECIAL ENGAGEMENT NO PASSES OR DISCOUNT COUPONS ACCEPTED

Dance

Thumps and jumps

New Guinea performance troupe raises the pulse

Call it a dialogue between dance and drums, ancient and new, African and American

Les Ballets Africains, which is slated to perform on Saturday at the Detroit Opera House, melds traditional African dance, music and ritual with elements of Western stage performance

The combination is 'interstellar high energy,' said Vince Paul, tour producer and former Farmington Hills resident.

The show unites both musicians and dancers on stage for the audience to see with some members doing double-duty by alternating between instrument and movement

Les Ballets Africains, which was founded in 1952, comes from the Republic of Guinea on Africa's west coast. The group has toured widely, even making appearances at the Kremlin and the White House. Although often presented as an ambassador of African culture, the 30-member group has never performed in downtown Detroit, said Paul.

'The dance that they're doing is thousands of years old. This is like African classical,' said Paul.

Even the instruments have roots

INSTRUMENTS

The djembe, considered a magical drum in West Africa, serves as the group's primary instrument. Other drums include the doundoun, which is carved out of wood, the kenkeni, which is played in conjunction with a small bell to create dual rhythms, and the krin, historically used to transmit messages in the forest.

'There are moments when there are 30 drums being played, and the stage is pounding,' Paul said.

Reciprocating the percussive sound is acrobatic and athletic dance and movement

ANCIENT DANCE

What Les Ballets Africains

When 8 p.m. Saturday, March 27

Where Detroit Opera House
1526 Broadway Detroit

Tickets: \$23-\$43 call (313) 237-SING or TicketMaster at (248) 645-6666 For more information visit www.MichiganOpera.org

'They're really quite superhuman,' said Paul. A large part of the show is the acrobatics that they can do, they flip and twist in the air in their own brand of gymnastics."

One dancer's signature back flip ends on a one-footed landing

At the same time, the just-under-two hour show tells the story of Guinea from the days of French colonialism to the present

'There's even a moment where the girls are wearing hip Nike pants and sweatshirts, which is to say, now, we wear clothes like this,' said Paul.

In contrast, other portions of the performance bring out dancers donning authentic ritual attire and masks. "We structure the show in a way that's accessible to an American audience, said Paul. "But this is the real movement, the real costumes, what you would actually see'



Les Ballets Africains combines traditional African dance and music with acrobatics and storytelling

WORLD ARTS INC

SUMMER SCIENCE CAMP

2004

REGISTER TODAY!

Weeklong camps begin June 21 for children entering grades 1-6.

Campers will enjoy:

- Theater shows
- Hands-on programs
- Five exhibit laboratories
- Outdoor habitat exploration

Keenote Summer Musikamps for children ages 3 months to 5 years begin August 2.

Choose from 3 unique themes that encourage parent-child interaction in a fun, musical environment

Camp Registration: 313.577.8400, Option 5

THE NEW DETROIT SCIENCE CENTER
5020 John R. Street • Detroit
313.577.8400
www.detroitssciencecenter.org

HADASSAH

Greater Detroit Chapter of Hadassah

FAMILY FUNFAIR

SUNDAY, MARCH 28, 2004 Noon - 4 p.m.

Costick Activity Center
11 Mile East of Middlebelt, Farmington Hills

FUN FOR ALL AGES!

pizza, pop and snacks available for purchase

Magicians!
Carnival Games and Prizes!
Balloon Animals!
Moonwalk and Petting Farm
Entertainment by Living Energy!
Face-painting and Tattoos

All activities are Free with paid admission

For more information, call
Hadassah - 248-683-5030

SPONSORS:

MetroParent

MAGAZINE

JN

DETROIT JEWISH NEWS

Observer & Eccentric

NEWSPAPERS

TICKETS

\$5.00

FAMILY TICKET

\$20

(Admits 5)

Become a Hadassah Member and receive a free family ticket

People have the power

For a night out, these places get your vote

Sometimes, you have to raise your nose from the grindstone. That's because it's good to see what's going on in the world around you - a wrecking ball could be swinging toward the grindstone to make way for a new Starbucks.

Now that you're scanning the scene, you might want to take in a little entertainment, and there's all kinds in metro Detroit. Here are our People's Choice Awards on some premier places to play.

BEST CASINO

Greektown Casino

Would the Church Lady celebrate a jackpot with her wacky dance? The casino's new Saturday Night Live Slot Room features comedian Dana Carvey's Church Lady visage, along with the Blues Brothers, Coneheads and other icons from the TV show. The SNL Room is the latest attraction at the casino, which opened in

2000. It features 75,000 square feet, more than 90 gaming tables and 2,500 slots. It's also a popular hangout before Tigers and Lions home games, with Comerica Park and Ford Field just a few slot token tosses away.

Runners up: Motor City Casino, MGM Grand Detroit Casino

BEST PLACE TO STRIKE OUT

Thunderbird Lanes

It's "pindemonium" when night league members or open bowlers send pins careening to the floor at this 46-lane Troy bowling mecca, home to Rock and Bowl on Friday nights and a Sunday NASCAR men's and women's mixed league. Other fun promotions include a Schools Out Special 9 p.m. to midnight Tuesday-Thursday, when games are \$2. The alley hosts tournaments, has a full-menu snack shop and lounge and offers short season leagues.

Runners up: Super Bowl, Garden Bowl

BEST COMEDY CLUB

Mark Ridley's Comedy Castle

The oldest and best-known comedy club in metro Detroit is still the best, after spawning a number of successful comedians including TV's *Home Improvement* star Tim Allen. The club hosts national and local acts, with improv nights on Tuesdays and open-mike nights on Wednesdays. A private room is available for parties and corporate functions.

Runners up: Joey's Comedy Club, Second City

BEST PLACE TO SEE A PLAY

Fisher Theatre

Opened as a movie and vaudeville house in 1928, the Fisher has featured big Broadway stars, including Mary Martin, Carol Channing, Joel Grey, Bernadette

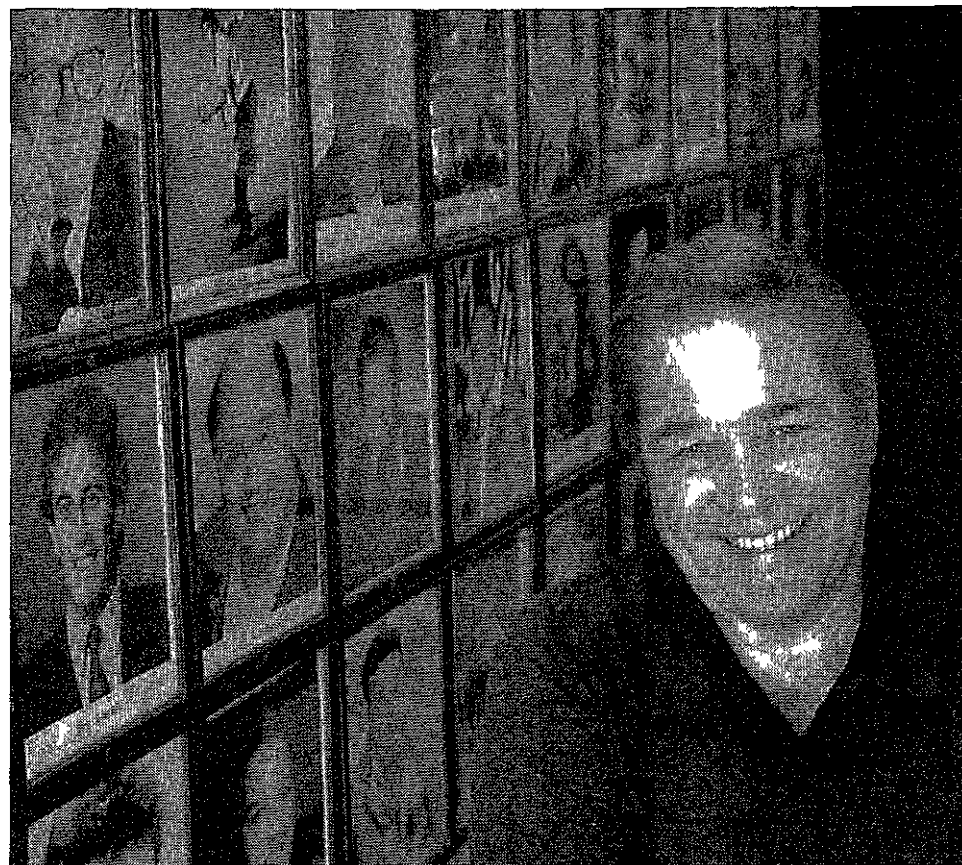

Mark Ridley's king of the castle, comedy that is

Peters and Lynn Redgrave, and world premieres of *Hello Dolly*, *Fiddler on the Roof*, and *Sweet Charity*. The tradition continues today, as Mia Farrow performed earlier this month in *The Exonerated*. Popular offerings *Chicago* and *The Graduate* are slated for spring.

Runners up: Fox Theatre, Meadow Brook Theater

BEST CHILDREN'S ATTRACTION

Detroit Zoo

The zoo already holds an unfair advantage over competing kids' attractions, with

its stable of elephants, giraffes, zebras, tigers and lions and other colorful creatures. And now they're going one better, by offering a Summer Safari where kid campers ages 4-13 can choose from a variety of single-day, weeklong and overnight sessions at the zoo. Single-day adventures include Urban Safaris in which kids learn about familiar zoo animals and the animals that live around us. The Zoo Snoozzz allows campers to learn about nocturnal animals.

Runners up: Detroit Science Center, The Henry Ford

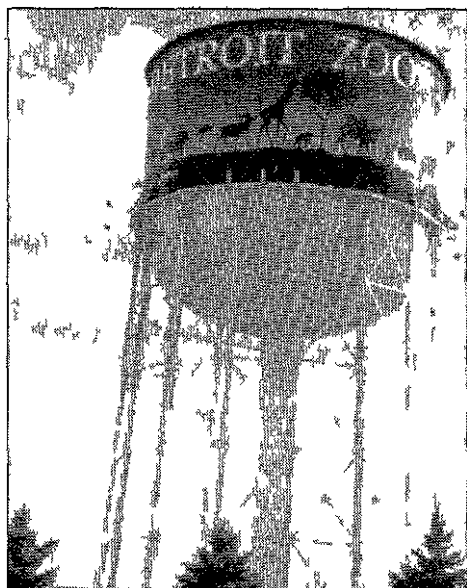

The Detroit Zoo received the most votes for best children's attraction.

PLEASE SEE BEST, E11

BEST

FROM PAGE E10

DOWNTOWNS

You can forget all your troubles, forget all your cares when you're downtown, because it's fun to shop and soak in what's special about main streets in Metro Detroit, ranging from historic to hip

■ Best downtown to hang out in Birmingham

Cool stores, art galleries, theaters and restaurants draw everyone from giggly teens and hipsters to natty-dressed oldsters and the executive class

On these downtown streets, it's not uncommon to bump into celebrities ranging from Britney Spears to Rod Stewart, hitting the streets for a little shopping or sightseeing during a stay at the Townsend Hotel

Runners up Plymouth, Rochester

■ Best downtown for wild night out Royal Oak

What happens in Royal Oak stays in Royal Oak? Woody's Diner on 5th Avenue along the railroad tracks is great for people watching, while Fifth Avenue Billiards, Mr B's and other downtown taverns also pack in the patrons on week-ends

Add to the mix a slew of restaurants, Mark Ridley's comedy club, bands at the Royal Oak Music Theater and Memphis Smoke, and you've got lots of opportunity to shed the yoke of daytime responsibilities, if only for a few carefree hours

Runners up Pontiac, Windsor

■ Best downtown to find a date Royal Oak

We're talking about conditions that are favorable to spawning relationships and Royal Oak's got them, thanks to the aforementioned abundance of night spots, the kind that draw attractive fun people - the kind of people most of us desire to hang with even after hours, in that sweet discovery phase of a new relationship, before family breeds contempt and the divorce lawyers are called in to end it all

Runners up Birmingham, Ann Arbor

BEST PLACES TO WATCH A GAME

■ Champps

Plenty of TVs, plenty of space, plenty of warm wood accents and a kitchen where the chef makes food from scratch and is allowed to get creative with menu offerings

It's a premise that makes this popular restaurant chain unique

Runners up. Mr B's, Oxford Tap Room

■ Comerica Park

It's not Tiger Stadium, but it also doesn't have those annoying posts to look around

And who cares if the field is so big that it takes a really long ball to clear the out-field fences?

There are fun rides for little sluggers, super-wide concourses, and a sweet

CASINOS

■ Greektown Casino 555 E Lafayette Ave, Detroit, (888) 771 4FUN (4386)

■ Motor City Casino, 2901 Grand River Ave Detroit, (877) 777 0711

■ MGM Grand Detroit Casino, 1300 John C Lodge, (877) 888 2121

BOWLING

■ Thunderbird Lanes 400 W Maple Road Troy (248) 362 1660

■ Super Bowl 45100 Ford Road, Canton (734)-459 6070

■ Garden Bowl, 4120-4140 Woodward Ave Detroit, (313) 833-9700

COMEDY CLUBS

■ Mark Ridley's Comedy Castle 269 East Fourth St Royal Oak, (248) 542 9900

■ Joey's Comedy Club 36071 Plymouth Road, Livonia, (734) 261-0555

■ Second City 2301 Woodward Ave Detroit

BEST PLACE TO SEE A PLAY

■ Fisher Theatre, 3011 W Grand Boulevard Detroit, (313) 872-1000

■ Fox Theatre, 2211 Woodward Detroit (313) 983-6000

■ Meadow Brook Theatre Rochester (248) 370-3300

BEST CHILDREN'S ATTRACTION

■ Detroit Zoo 8450 W Ten Mile Road, Royal Oak (248)398-0900

■ Detroit Science Center, 5020 John R, Detroit, (313) 577-8400

■ The Henry Ford, 20900 Oakwood, Dearborn, (313) 271-1620

BEST PLACE TO WATCH A GAME

■ Champps has lots of metro Detroit locations including, 19470 Haggerty Livonia, 301 W Big Beaver, Troy, visit www.champps.com for more

■ Mr B's 215 S Main St Royal Oak, (248) 399-0017

■ Oxford Tap Room, 36 S Washington Oxford, (248) 236-0380

view of the downtown skyline And don't forget Ivan "Pudge" Rodriguez
Runners up Joe Louis Arena, Ford Field



☘ Come and Enjoy Our Little Piece of Ireland!

As you step across the threshold here in Shanahan's we bid you welcome Cead Mile Failte, which in the words of the Celt is a hundred thousand welcomes

My family takes great delight as your host, leading you through an experience that is as real as the river Shannon

The theme of this little piece of Ireland is hospitality Join us as you enter through the Torc, our symbolic threshold, inspired by the most beautiful adornment a Celtic chieftain could bestow on the maiden of his heart to experience a Shanahan welcome

Join us for lunch and ask us about our Good Neighbor Discount Card. Come by in the evening and enjoy live entertainment Sunday, Tuesday, Thursday, Friday and Saturday. ☘

SHANAHAN'S

IRISH PUB

17123 N Laurel Park Dr
Livonia, MI 48152
734-462-2096
734-462-2196 (Fax)

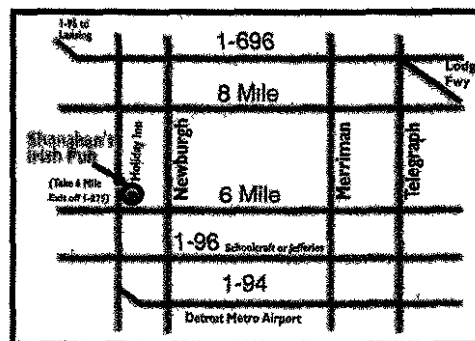

E·R·N·E·S·T·O·S

An • Italian • Country • Inn

Easter Day

All Day Buffet

Sunday,
April 11th, 2004

Easter Brunch Buffet
10 am- 2 pm

Easter Dinner Buffet
2 pm-6 pm

Adults \$24.95
Children 6-10: \$9.95
Children 5 and Under
Complimentary

Call For Reservations!
734.453.2002
41661 Plymouth Road • Plymouth

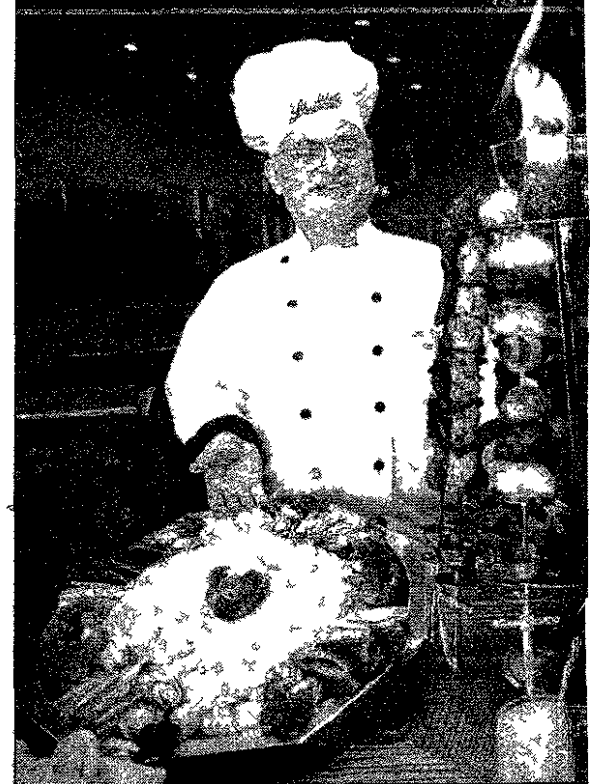

Table hopping

Foodwong

LOCATING THE BEST OF:

- Bangkok Kitchen - 34731 Grand River Ave Farmington (248) 471 7211
- Benihana - 985 W Big Beaver Road Troy (248) 649 6340
www.benihana.com
- Buca di Beppo - 270 N Old Woodward Ave Birmingham (248) 540 9463 38888 Six Mile Road Livonia (734) 462 2077
www.bucadibeppo.com
- El Nibble Nook - 27725 8 Mile Road Livonia (248) 474-0755
- Inn Season Cafe - 500 E Fourth St Royal Oak (248) 547-7916
- La Shish 37610 W 12 Mile Road - Farmington Hills (248) 553-0700
www.lashish.com
- Max & Erma's - 250 Merrill St Birmingham (248) 258 1188
www.maxandermas.com



La Shish executive chef/senior vice president Jamil Eid (left) is seen here with a variety of items you'll find on the menu at the new La Shish Livonia and a regular display of 12 skewers of shish kabob, shish tawook kafta,

- BURGERS
- chicken
- fish • shrimp
- clam baskets
- pizza • soup
- sandwiches
- appetizers

DOYLE'S Tavern

OPEN MON SAT
11AM 2AM

SUNDAY
NOON-2AM

HAPPY HOUR

11AM 7PM MON SAT
ALL DAY SUNDAY

FOOD * SPORTS * SPIRITS

860 FRALICK • PLYMOUTH • 743-207-9656

(1 block N of Penniman, off Mam Street)

CELEBRATE

and Watch All Your Favorite Sports

Look for our Patio
to Open Soon!



The people have spoken

BY ELEANOR HEALD
CORRESPONDENT

■ Best place to take a first date: The Lark

After receiving top awards from the likes of *Conde Nast Traveler*, *Gourmet* magazine and *Distinguished Restaurants of North America*, The Lark may be the best place to take a first date. You better be serious because it's going to cost you. Chef de Cuisine Kyle Ketchum offers his interpretation of French cooking techniques at \$65-\$75 per person excluding beverage or tip. The food and hospitality of owners Mary and Jim Lark are first rate.

Runners-up: Bahama Breeze, Emily's

■ Best for brunch: The Whitney

On Sundays, the 21,000-square-foot pink granite mansion with 52 rooms, built by lumber baron David Whitney, serves up a generous brunch. It's a good way to get introduced to The Whitney if you've not been or get reacquainted if you've not been there in awhile.

Runners-up: Beverly Hills Grill, Townsend Hotel

■ Best restaurant to take your kids and still feel like you're an adult: Max & Erma's

One of the better chain restaurants catering to families. With over 75 locations in 11 states, its casual dining philosophy is among the best. In addition to great sandwiches and burgers for kids, their parents have voted the tortilla soup, classic Santa Fe salad and Tuscan chicken their favorites. Grown-ups dig the burgers, too.



Hungry for Italian, and want a good seat? Seated (from left) Ryan

Runners-up: Red Robin, Best Italian: Buca di Beppo

Buca di Beppo, translate about fun and gigantic portions. There's full bar service, with live music from the Passion Pit seated with its shrine to Frank Sinatra. Good.

Wonderful food



FILE PHOTO BY MATTHEW TAPLINGER

nd Charles Saad, vice president of operations present some of the other La Shish locations. The Flaming Tower, (center) is a spectacular shrimp, swordfish and vegetables

- Merchant's Fine Wine - 146 N Main St. Royal Oak (248) 546 7770
21034 Mack Ave. Grosse Pointe Woods (313) 417 0400 22250
Michigan Ave. Dearborn (313) 563 8700 www.merchantsfinewine.com
- Peabody's - 34965 Woodward Ave. Birmingham (248) 644 5222
- PF Chang's China Bistro - Somerset Collection South 2801 W Big Beaver Road Troy (248) 816 8000
- Ram's Horn - 31253 Woodward Ave. Royal Oak (248) 549 4130 and many locations in metro Detroit
- The Grill - Ritz Carlton Hotel 300 Town Center Dr. Dearborn (313) 441 2000
- The Lark - 6430 Farmington Road West Bloomfield (248) 661 4466
- The Whitney - 4421 Woodward Ave. Detroit (313) 832 5700

Spoken out on area eats



...ive atmosphere? Try Buca di Cook, Nicky Hogue and Kim Hogue

family Buggy

l as Joe's basement, is all ions at reasonable-prices es and beer. Humor reigns, y; six on to the Wine Room atra. The pizzas are really

- Runners-up Deluccas, Il Posto
- Best Middle Eastern La Shish

With identical menus in each of its metro-area locations, La Shish has brought Lebanese-style Middle Eastern dishes to the pinnacle. Hallmarks are the fresh-baked pita, lamb chops, marinated in a special La Shish marinade, then grilled, shish tawook (chicken kabob), and fattoush (a vegetarian salad). Because it's part of Lebanese culture, many vegetarian dishes are on the menu.

- Runners-up Phoencia, Pine Land
- Best for Thai Bangkok Kitchen

With origins in the palace of the kings of Siam, Thai food has taken metro Detroit by storm. Characteristic tastes come from an aromatic mixture of salt, pepper, garlic, basil and Thai peppers pounded together. These are enhanced by herbs, spices, cilantro, ginger root, galangal (from the ginger family), lemongrass and kaffir lime. Add nam pla (fish sauce) for a salty dimension and coconut milk for creamy texture. Readers believe Bangkok Kitchen does it best!

- Runners-up Sy Thai, Orchid Cafe
- Best for Sushi. Benihana

Japanese cuisine was unknown to the United States when the first Benihana opened in 1964. Having a Japanese chef prepare a meal at tableside was a radical

PLEASE SEE RESTAURANTS, E14



SEAN O'CALLAGHAN'S
Traditional Irish Pub & Restaurant

Sunday Brunch!

Every Sunday, Starting April 4th
Sean O'Callaghan's will be open for brunch
10:30 am - 2:00 pm

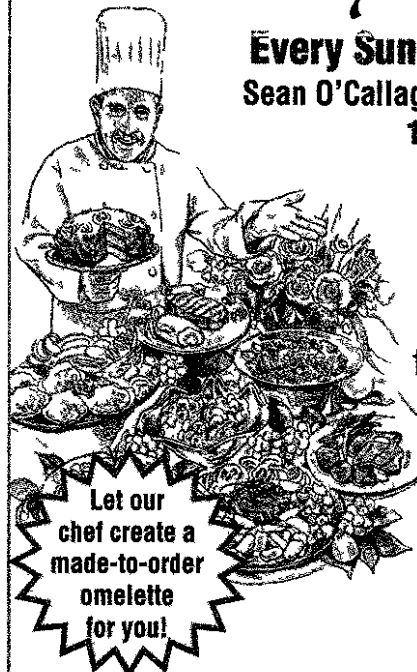

Let our chef create a made-to-order omelette for you!

Enjoy our large selection of breakfast and lunch items, Eggs Benedict, Belgian waffles, freshly baked pastries, smoked Atlantic salmon and many other traditional favorites

Adult...\$14.95
Children
(11 and under)...\$7.95

821 Penniman Ave. • Downtown Plymouth • 734-459-6666 • www.seanocallaghans.com

Bring Your...

- Guitar
- Horn
- Voice or
- Special Talent

Every
Wednesday
from 8 p.m.
to 11 p.m.



FREE APPETIZERS • DRINK SPECIALS
DRAFT BEER only...\$1.50

885 Starkweather • Plymouth

734-459-0885

02061071 5

0 E001 07 11 3

RESTAURANTS

FROM PAGE E13

idea. Now sushi is a favorite all over the US and Benihana is obviously the people's choice in this area.

Runners-up Musashi, Little Tree
Best for Chinese PF Chang's China Bistro
 Attaining harmony of taste, texture, color and aroma by balancing the Chinese principles of fan (rice, noodles, grains and dumplings) and t'sai (vegetables, meat, poultry and seafood), PF Chang's has taught the American palate to love Chinese and the innovative influence of southeast Asian cooking on modern Chinese cuisine
 Runners up Mon Jim Lau New Peking

Best for Mexican El Nibble Nook
 If you don't want to head to Mexicantown, then the "Nook" that has served Mexican food, margaritas and freshly made tortilla chips to generations is a good bet.
 Runners-up On the Border, Mexican Fiesta
Best for vegetarian fare Inn Season
 Vegetarian is not only a lifestyle, it's healthy eating. There's nary a poll that doesn't put Inn Season first. The first bite of most dishes will make you forget that it's vegetarian.
 Runners up Seva, Blue Nile
Best for wining and dining clients Peabody's
 To the "P" in the name, add pricing, which is moderate, and prime rib, a classic at this eatery, which is a Birmingham tradition. Seal the deal with prime rib and a good bottle of cabernet sauvignon

Runners-up Capital Grille, Kruse & Muer
Best place to say "I love you" and then have dinner The Grill, Ritz-Carlton
 A renovation has given The Grill a new look, even more intimate and elegant. Chef Stephen Jalbert's creative American cuisine and the restaurant's legendary service remains but are showcased even further. And the I love you part? Say that over one of the decadent desserts.
 Runners-up Cafe Cortina, Fox & Hounds
Best late-night menu Ram's Horn
 If you're into the area's bar scene, you know this is the place people go after the bar when you're hungry. There's something for everyone here, but American fare is best.

ordered as a generous hamburger
 Runners-up Big Boy, Wendy's
Best place to learn about learn about wine while buying it Merchant's Fine Wines
 With locations in Royal Oak, Dearborn and Grosse Pointe Woods, Merchant's Fine Wines boasts one of the area's largest selections of fine wines, liquor and gourmet food-stuffs.
 The staff is friendly and knowledgeable, and is always happy to help make a selection.
 Runners-up Alban's Bottle & Basket, Papa Joe's
 Contact Eleanor Heald at focusonwine@aol.com

4-Star Italian Restaurant With Over 100 Years of Combined Experience by the Del Signore Family!

Livonia's Finest for 36 Years!



Fonte D'Amore
DEL SIGNORE

Special Requests Welcome

Book Your Special Event With Us!

32030 Plymouth Road • Livonia • 734-422-0770



Erin Gleason keeps smiling during the lunch rush at Peabody's, voted best restaurant for wining and dining

Buddy's RESTAURANT PIZZERIA
Since 1946

We're Your Party Headquarters!

Call us about...
 • Party Reservations • Carry-out Party Trays
 • All-you-can-eat Party Packages
 • Dine-in or Take-out • Gift Certificates
Voted #1 Square Pizza In Metro Detroit!

Recognized as One of the Nation's Best 5 Pizza Places...

food NETWORK

will air on the Food Network in March. Don't Miss It!

Visit our website at www.buddyspizza.com for times & listings and other great savings!

Livonia • 734-261-3550
 33605 Plymouth Rd. • W. of Farmington Rd.

Enjoy Our Freshly Made Soups & Pastas!

Farmington Hills • Bloomfield • Royal Oak • Auburn Hills • Dearborn • Detroit • Warren • Pointe Plaza

BEANS & CORNBREAD
A SOULFUL BISTRO

VOTED BEST SOULFOOD 6 YEARS RUNNING!

Early Dinner Specials \$10
 Everyday 3pm to 6pm

- Fried Chicken
- Catfish
- Meatloaf

With choice of 2 sides and dessert.

29508 Northwestern Highway (Sunset Strip)
 248.208.1680 • Carryout Available for \$11.50
www.BeansCornbread.com

Drinkology

Honey and spice make Frapin nice

BY ELEANOR & RAY HEALD
CORRESPONDENTS

Family-owned Frapin is a rarity among cognac producers

Frapin is one of the few cognac firms to own its own vineyards. It took five centuries to create the 741-acre domain, which includes 494 acres of prime Grande Champagne vineyard.

Frapin's holdings constitute the largest single vineyard in this top-rated Cognac appellation, where average holdings seldom exceed 30 acres.

Frapin VSOP cognac (\$40/750mL) is made exclusively from top grapes and is a blend with an average barrel age in Limousin oak casks of 10 to 12 years, as opposed to a minimum 4½ years required by law.

Elegant, round and smooth, drink it neat in a snifter, warmed only by your hands, never in a microwave or one of the candle contraptions.

Contact **The Healds** at focusonwine@aol.com

Best nightspots

Looking for a place to hang out? Here are some suggestions

Call them taverns, pubs, public houses, whatever, these establishments have long joined the church and the courthouse as societal institutions. Here is some input from readers on their favorite features of area bars.

BEST BARTENDER

Michael Emlaw at Streetside Seafood

Emlaw remembers customers and what they like to drink. "He loves sports and can talk with the guys," said Bill Roberts, owner of Streetside Seafood and the Beverly Hills Grill. "I think the ladies are charmed by him. He hits all the bases and can chat with anyone. He's also very well versed on wines. Emlaw has been in the bar business 20 years, the last nine at Streetside. "I try to be professional. I can anticipate what people want and need." He typically works the 6 p.m. to closing shift Tuesday-Saturday.

Runners up: Bob Kazanowski, Mason's; Heather, Jim and Brian at 220 Merrill Street & Edison Lounge.

BEST WINE BY THE GLASS

Streetside Seafood

The free samples can't hurt. "We offer a



Streetside Seafood bartender Michael Emlaw pours a glass of house wine.

taste of anything with the exception of reserved bottles," said general manager Anita Wilson, adding that at this seafood restaurant, champagne and white wine do not rule, as tradition would suggest. "We

sell a ton of red wine here, our distributors are shocked."

Runners up: Papa Vino's, 220 Merrill Street & Edison Lounge.

BEST MARTINI

Blue Martini

James Bond and Frank Sinatra may have passed on some of the non-traditional martini drinks with names like the Tango Tim and the Palm Beacher, but readers agree that this night spot shakes up the best martinis in town.

Runners up: 336 Main, Double Olive.

BEST BEER ON TAP

Dick O'Dow's

It's not enough to just serve their Guinness at the proper temperature, 38-42 degrees. At this downtown Birmingham mainstay, staff generate their own nitrogen-CO2 blend beer delivery system "so it cascades properly," said owner Mitch Black. There are lighter beers too, including the popular Smithwick's Irish ale, similar to Bass Ale but with a sweeter, smoother finish.

PLEASE SEE NIGHTSPOTS, E16

Mark Ridley's
COMEDY CASTLE

269 E. Fourth Street
Downtown Royal Oak
248-542-9900
www.comedycastle.com

Mark Ridley's Comedy Castle, in downtown Royal Oak, is offering the best stand up comedy the Metro Detroit area has to offer.

We're celebrating our 25th year in business...Come see why!

Tuesday is improv Night with 'Totally Unrehearsed Theatre' Mark Ridley's house improv troupe and Metro Detroit's most hilarious group.

Wednesday is "Open Mike Night". Think you got what it takes?

And...every weekend, we feature National Headliners

Upcoming Acts:

March 25th-27th: Mike Birbiglia

He's been seen on Comedy Central's "Premium Blend" and "The Late Show with David Letterman". Also appearing with Mike Birbiglia will be Melvin Bender and Jim McLean.

FREE ADMISSION FOR TWO!
for the Thursday Evening 8:00 p.m. Show (21 or Older)
Not Valid for Special Engagements
Reservations Required • Call 248-542-9900
Expires March 25, 2004

www.hometownlife.com

COME PARTY WITH US!

Monday	J. RAY EXPRESS
Tuesday	THE SHOWTIME BAND Dance to the Oldies
Wednesday	J. RAY EXPRESS Loads of Special Irish Tunes!
Thursday & Friday	RATTLEBOX
Saturday	IMPACT SEVEN Motown
Sunday	KARAOKE You're the Entertainment!

NEW MENU • KITCHEN OPEN NIGHTLY UNTIL 12:00 A.M.

CRYSTAL LOUNGE

8701 Beech Daly • Dearborn Hts. • Mon.-Sat. 11am-2am; Sun. Noon-2am
(313) 274-9645

Observer & Eccentric | Thursday March 25 2004 • (**) E15

Kid Rock n' Road Trip Getaway BOARDING PASS



Grand Prize winner will receive roundtrip airfare for 2 hotel accommodations and 2 tickets to see Kid in concert at the Universal Amphitheatre on April 24th. Mail entry form to "KID ROCK ROAD TRIP" c/o 101 WRIF, One Radio Plaza Detroit MI 48220. Readers may also send in a postcard with name, address and daytime phone number to the address above. All eligible entries will be placed into the grand prize drawing that will take place at the WRIF studios on or about April 7, 2004.

Name _____

Address _____

City _____ State _____ Zip _____

Home Phone _____

Work Phone _____

Age _____

No purchase necessary. See complete official rules for details.

For official rules visit www.wrif.com

NIGHTSPOTS

FROM PAGE E15

Runners up Rochester Mills Brewing Co., Box Bar

BEST BAR FOOD

Mason's

Readers say this popular lunch and after work meeting spot that also doubles as a sports lounge serves up not just the finest burgers in Metro Detroit, but in the whole U.S.A. The 1/3-pound patties are served in red baskets with fries.

Runners up Dick O'Dow's, Miller's Bar

BEST GAME ROOM

Dave & Busters

Flashing lights, bells and whistles greet those entering the oversized Million Dollar Midway arcade with games including Daytona U.S.A., where you can win tickets to exchange for prizes. There are also billiards, shuffleboard, a golf simulator and electronic games.

Runners up Snookers, Gameworks

BEST JUKEBOX

Mt Chalet II

The wide variety of music available on this tavern's jukebox draws notice from readers. They play a lot of Squeeze, Bob Marley, Dave Matthews, Tom Petty, Talking Heads, Kid Rock, Pretenders, hip

hop, Smashing Pumpkins," said waitress Trina Ashburn.

Runners up Johnny Rockets, Gusoline Alley

BEST IRISH PUB

Dick O'Dow's

Owner/bus boy Mitch Black has some ideas on why readers favor his place. "It's exactly what an Irish pub is supposed to be, it's a center of the community." The 150-year-old tavern shipped in pieces from Ireland and opened in Birmingham in 1996. It hosts Theology on Tap discussions — headed by Holy Name Catholic Church on Tuesday nights — and Bloomfield Chamber of Commerce meetings. This pub also has great burgers.

Runners up Sean O'Callaghan's, Duggan's

BEST HAPPY HOUR

220 Merrill Street & Edison Lounge

"I don't do any special prices or anything," said general manager Frank Tillman. "It's just a place where everyone after work kind of congregates and relaxes, they meet their friends — everyone has a good time."

He's talking about the Realtors, brokers and other sharp-dressed Birmingham business professionals who show up for conversation and to check out sports or market results on TV.

Runners up TGI Friday's, McCormick & Schmick's

BARTENDER

■ Michael Emlaw - Streetside Seafood 273 Pierce St. Birmingham (248) 645-9123

■ Bob Kazanowski - Mason's, 13490 Farmington Road, Livonia 734-427-0650

■ Heather Watson, Jim Flaumerfelt and Brian Fritzerman - 220 Merrill Street & Edison Lounge 220 E Merrill, Birmingham, (248) 645-2150

BEST WINE BY THE GLASS

■ Streetside Seafood - 273 Pierce Birmingham (248) 645-9123

BEST MARTINI

■ Blue Martini - 201 Hamilton Birmingham, (248) 258-3005

BEST BEER ON TAP

■ Dick O'Dow's - 160 W Maple, Birmingham, (248) 642-1135

BEST BAR FOOD

■ Mason's - 13490 Farmington Road

Livonia 734-427-0650

■ Dick O'Dow's

■ Miller's Bar - 23700 Michigan Dearborn, (313) 565-2577

BEST GAME ROOM

■ Dave & Busters - 4511 Park, Utica, (810) 930-1515

■ Snookers - 30295 Woodward Ave., Royal Oak (248) 435-0030

BEST JUKE BOX

■ Mt Chalet II - 32955 Woodward Royal Oak (248) 549-2929

■ Johnny Rockets - 4368 Baldwin Auburn Hills, (248) 745-3445

BEST IRISH PUB

■ Dick O'Dow's - 160 W Maple Road Birmingham (248) 642-1135

■ Sean O'Callaghan's - 821 Penniman Plymouth (734) 459-6666

BEST HAPPY HOUR

■ 220 Merrill Street & Edison Lounge

Music

Kid Rock's all over the place

Let's unofficially call this week Kid Rock Week as Detroit's favorite twangy rocker plays to metro Detroiters at two different venues

He's at The Palace tonight and Cobo on Friday. Tickets are still available. The



Kid Rock is playing in the Motor City this week

Twisted Brown Trucker Band, of course, is playing with him

Is Kid Rock mimicking Bob Seger's career? He's trying to. Rock said at the Rock n' Roll Hall of Fame in Cleveland last week, Seger is his hero

Here are some similarities

■ In Seger's heyday, he and The Silver Bullet

Band also played numerous consecutive shows in the Motor City. A full week at Pine Knob in the 1970s and '80s were common

■ Seger seemed to be everywhere in the Motor City - basketball games, big rock shows etc. Kid's doing the same thing. You might see him at Pistons' games or jumping on stage at concerts, anything from B B King to Lynyrd Skynyrd

■ They're both proud to be from Detroit. Any Seger fan knows his famous concert line boasting the city. "They say Detroit audiences are the best audiences in the world. I said, 's---t I've known that for 10 years'" Rock remembers his roots too, we hear him constantly boasting about how much he loves the Midwest on his albums

■ Seger made it cool to sing about the hardships of a rock star on the road with his song, *Turn the Page*. Rock's done the same in his songs *Cold and Empty* and *Rock n' Roll Parn Train*, both from his new album

■ All of Seger's Silver Bullet albums were hugely successful, Kid Rock's Twisted Brown Trucker albums are the same

Seger was inducted into the Hall of Fame last week. Let's hope Rock will eventually make his way there too

KID ROCK

With The Twisted Brown Trucker Band and special guest Puddle of Mudd

When: 8 p.m. today at The Palace, and 8 p.m. Friday at Cobo Hall

Tickets: \$37.50 at the Palace, \$38.50 at Cobo, call (248) 645-6666 or www.ticketmaster.com

it's drawing near

SOME OF THE NATION'S BEST ARTISTS PUT THEIR ACCENT ON ART

Ann Arbor national spring art show

Saturday, April 3rd, 10 AM - 6 PM
Sunday, April 4th, 10 AM - 5 PM

University of Michigan's Indoor Track Building • 1000 State St.

\$5.00 Admission • Free Parking

APRIL 3RD & 4TH 2004



Contact Ron Beahn 330-896-9498
or rbeahn@neo.rr.com



Services of Michigan Public Media

Get Out!

Your Guide to Entertainment

Send fax or e-mail items for consideration in Get Out! To Keely Kaleski, assistant managing editor for features Observer & Eccentric Newspapers, 805 E Maple, Birmingham, MI 48009, fax (248) 644 1314 or e-mail kkaleski@oehomecomm.net

PROFESSIONAL THEATER

Gem Theatre

Menopause The Musical 8 p.m. Tuesday Saturday 4 p.m. Saturday and 2 p.m. Sunday Theatre 333 Madison Detroit \$39.50 groups of 10 14 \$36.50 (313) 963 9800 Ticketmaster at (248) 645 6666 or visit www.gemtheatre.com

Planet Ant

Living with the Sevensen's an all original comedy play 8 p.m. Friday Saturday 2 p.m. Sunday \$15 adults \$10 students with/ID 2357 Caniff Hamtramck (313) 365 4948 Ext 1 www.planetanttheatre.com

Macomb Performing Arts Center

Capitol Steps 8 p.m. Friday \$32 \$27 students/seniors \$24 Bobby Vinton 8 p.m. Sunday \$40 students/seniors \$36 44575 Garfield Road Clinton Township (586) 286 2222 (800) 585 3737 www.macombcenter.com

Fox Theatre

Miss Saigon through Sunday Curtain 8 p.m. Thursday Saturday 7:30 p.m. Sunday and 2 p.m. Saturday Sunday Tickets are \$28 \$73 at the Fox Theatre and Joe Louis Arena box offices and Hockeytown Authentics in Troy and all Ticketmaster locations. To charge tickets call (248) 433 1515 Call (313) 471 6611 or visit www.OlympiaEntertainment.com

Theatre Company

The Robber Bridegroom by Alfred Uhry music by Robert Waldman Bawdy Southern fairy tale 8 p.m. Thursday Saturday 2 p.m. Sunday no performance Sunday March 28 McAuley Theatre on the Outer Drive campus of the University of Detroit Mercy 8200 W Outer Dr \$12 seniors \$10 students with ID \$8 (313) 993 6461 www.udmtheatre.com

COMMUNITY/COLLEGE THEATER

Ridgedale Players

Guys & Dolls 8 p.m. Friday Saturday 2 p.m. Sunday 205 W Long Lake Road

Troy \$15 students & seniors \$14 (Sunday) (248) 988 7049

Broadway Onstage

Graceland & Asleep on the Wind two companion one act comedies by Ellen Bryon open on Friday Shows 8 p.m. Friday Saturday Broadway Onstage Live Theatre 21517 Kelly Road at Toepfer (8 1/2 Mile Road) Eastpointe \$15 (586) 771 6333

Clarkston Village Players

Trophies by John J. Wooten 7:30 p.m. Thursday 2 p.m. Sunday 8 p.m. Friday Saturday Clarkston Village Players Depot Theatre \$10 Thursday \$12 Friday Saturday (248) 625 8811 or www.clarkstonvillageplayers.org

Oakland Theatre Guild

Jekyll and Hyde 7:30 p.m. Friday Saturday 2 p.m. Sunday Starlight Theater in Summit Place Mall 315 N Telegraph corner of Elizabeth Lake Road Waterford \$14 seniors/children under 12 \$12 (248) 335 1788 www.starlighttheater.net

Park Players

Man of La Mancha dinner show 6:30 p.m.



THE GEM THEATRE

Rhonda Freya English, formerly of Southfield, plays 'Power Woman' in 'Menopause The Musical' now playing at the Gem Theatre in Detroit. Call (313) 963-9800, Ticketmaster at (248) 645-6666 or visit www.gemtheatre.com for more information

Saturday \$25 Wine & Cheese with show 8 p.m. Friday Saturday April 2 3 \$20 12:30 p.m. Sunday brunch with show \$22 N. Rosedale Park Community House 18445 Scarsdale Detroit (313) 837 9082

Genitt's Hole in the Wall

Wedding Bell Blues interactive dinner theater comedy \$45 per person *The Trouble with 12* children's lunch theater interactive comedy Saturday Sunday \$14.95 kids \$16.95 adults 108 E. Main St Northville (248) 349 0522 for reservations/info

EMU

The Yellow Boat by David Saar true story of Saar's 8 year old son Benjamin and his experience with hemophilia and AIDS 8 p.m. Friday Saturday March 26 27 8 p.m. Thursday Saturday April 1 3 2 p.m. Saturday Sunday March 27 28 and Saturday April 3 Sponberg Theatre on EMU's Ypsilanti campus \$8 Thursday \$14 Friday Saturday \$12 matinee (734) 487 1221

YOUTH THEATER

Marquis Theatre

The Shoemaker and the Elves 2:30 p.m. Saturday Sunday through May 2 1:35 E. Main St. Northville No children under 3 \$7.50 (248) 349 8110

First Theatre Guild of Birmingham

The Emperor's New Clothes 8 p.m. Friday Saturday 2 p.m. Sunday Knox Auditorium First Presbyterian Church 1669 Maple Birmingham \$8 adults \$5 seniors/students Seniors get in free on Sunday (248) 644 2087 Ext 151

AUDITIONS

Village Players of Birmingham

The Recruiting Officer restoration comedy with music 7 p.m. Sunday March 28 and Tuesday March 30 Village Players 34660 Woodward Ave. Birmingham Registration 6:30 p.m. performances June 14 20 (248) 643 0971

The Civic - Live!

Talent showcase at the Civic Theatre in downtown Farmington on May 22 23 Seeking singers dancers musicians comedians magicians impressionists novelty acts Open to all Detroit area performers all ages and professions Auditions open through Thursday April



Kaeshi and Amar are members of the Bellydance Superstars who are presenting two shows at The Magic Bag in Ferndale on Saturday and teaching a basic dance workshop on Sunday at The Community House in Birmingham. Both were dancers at the Aladdin in Las Vegas. For more information about the show call (248) 645 6666. To learn more about the workshop visit www.bellydancesuperstars.com

15 call (248) 474 5500 Ext 215 for details

Barbershop

Wayne Chapter of the Barbershop Harmony Society meets 7:30 p.m. Tuesday at Kirk of Our Savior Presbyterian Church 36660 Cherry Hill Road 1/2 mile east of Newburgh Westland Gentlemen interested in singing in the chapter's Renaissance Chorus or who enjoy quartets can call Bob Wolf (734) 421 1652 or come to any rehearsal

GALLERIES/ART

ACT Gallery

Redux Tables and Chairs Transformed silent auction bidding begins 6:30 p.m. Friday closing reception 6:30 p.m. Friday April 23 bidding continues during normal gallery hours noon to 5 p.m. Friday Saturday or by appointment 35 E. Grand River Detroit upstairs from Galleria Biegas (313) 961 4336

Lawrence St. Gallery

Exposures Photography 04 eighth annual competition and exhibition March 30 April 30 opening reception 7 10 p.m. Friday April 2 22620 Woodward Ave. Suite A Ferndale open noon to 5 p.m. Tuesday Saturday (248) 544 0394 www.lawrencestreetgallery.com

Creative Art Center

Looking for women artists in all media and from all countries other than the U.S. or whose immediate family came from other countries. Call (248) 333 7849 for more information to cpaster@aol.com

D&M Studios

Taking reservations for Summer Art Camp Program Animals in Art 8881 N Lilley Road Canton call (734) 453 3710

JAZZ/BLUES/POPULAR

Matt Michaels Trio

With Barbara Ware vocals 7:30 11 p.m. Wednesday March 31 Ron's Fireside Inn 28937 Warren Garden City \$5 cover with dinner \$10 without dinner two drink min

imum reservations recommended (734) 762 7756

Trinity House Theatre

Benefit concert 8 p.m. Friday 38840 W Six Mile Road Livonia \$20 (734) 464 6302 or visit www.trinityhouse.org Features Mustard's Retreat Matt Watroba Ric Hordinski Whit and Al Hill Kim Taylor John Austin and Erin Echo Jill Jack 8 p.m. Saturday \$10

Music Menu

All star jam night 9 p.m. Saturday 511 Monroe St. near the corner of Beaubien and Monroe in Detroit's Greektown \$7 1 (313) 964 6368

Bugs Beddow Band

Cavern Club 201 S. First St. Ann Arbor 10 p.m. to 2 a.m. Friday Blue Martini 201 Hamilton Birmingham 8 p.m. to midnight Saturday www.bugsbeddow.com

Global Jazz Trio

Mark Hershberger with Muruga Booker and Richard Smith 9:30 p.m. Saturday Bakers Keyboard Lounge 20510 Livernois Detroit (313) 345 6300 www.bakerskeyboard.com www.globaljazztrio.com

Royal Oak Music Theatre

Great Big Sea with the Push Stars 6:30 p.m. (doors open) 8 p.m. (show) Thursday \$25 Ben Kweiler with Death Cag for Cutie 8 p.m. Tuesday March 30 \$15 318 W Fourth St. corner of Lafayette Royal Oak (248) 399 2980 (248) 645 6666

Killer Flamigos

10 p.m. Friday Saturday 80s dance music John Cowley & Sons 33338 Grand River Farmington (248) 474 5941 www.johncowleys.com

Bobby Lewis & the Crackerjack Band

9 p.m. to 1 a.m. Friday Saturday Silky's Martinis and Music Cafe 21931 Michigan Ave. Dearborn \$5 cover (313) 565 6278

Brother's Groove

8 p.m. to midnight Saturday Blue Martini 201 Hamilton Birmingham (248) 258 3005

Edison's

The Blue Kings 9 p.m. to 1 a.m. today Tall Cool One 9:30 p.m. to 1:30 a.m. Friday Saturday 220 Merrill St. Birmingham (248) 645 2150

Jazz at the Philharmonic

Big jam session 3 5 p.m. Sunday April 18 VisTaTechCenter Schoolcraft College Livonia Features Matt Michaels & Bill Meyer piano Dan Jordan & Paul Keller bass Jim Ryan & Jerry McKenzie drums Jeff Trudell percussion and others Two bands will jam separately and then come together at the conclusion of the concert Tickets \$15 in advance send check or money order payable to the Michigan Jazz Festival with a self addressed stamped envelope to Midge Ellis 20457 Maplewood St Livonia MI 48152 2022 No tickets sold at the door For more information call (248) 474 2720 or (734) 459 2454

CONCERTS

DSO

Salute to the Duke with Doc Severinsen 8 p.m. today 8 30 p.m. Friday Saturday 3 p.m. Sunday \$15 \$54 DSO Young People's Concert kids learn how an orchestra works 10 a.m. and 11 30 a.m. Saturday \$10 \$26 The Max 3711 Woodward Ave Detroit \$15 \$60 (313) 576 5111 www.detroitssymphony.com

UMS

The Talis Scholars Peter Phillips director 8 p.m. today St Francis of Assisi Catholic Church 2250 E Stadium Blvd Ann Arbor \$30 \$40 Jazz at Lincoln Center's Afro Latin Jazz Orchestra Music of the Latin Jazz Masters 8 p.m. Saturday Hill Auditorium 825 N University Ave Ann Arbor \$10 \$40 Lang Lang piano 8 p.m. Thursday April 1 \$10 \$50 Hill Auditorium (734) 764 2538 www.ums.org

Birmingham Musicales

Benefit concert 8 p.m. Friday featuring the Matt Michaels Trio Birmingham First United Methodist Church 1589 Maple Road Birmingham \$15 (students grades 1-12) \$20 general \$35 patron \$50 benefactor (248) 642 2386

The Optimistics & Friends

Music Makes the World Go Round 7 30 p.m. Friday Smith Theatre Orchard Ridge campus south of I 696 in Farmington Hills Demonstration of how music transforms lives A wide variety of styles will be featured Optimistics is a vocal group consisting of Beverly Williams husband and wife Betty and Vincent Little Friends consists of a five piece band and three back up singers \$15 discount for students/seniors (248) 522 3420

Dearborn Symphony Orchestra

Romantic Excursion & A Little Jazz 8 p.m. Friday Ford Community & Performing Arts Center 15801 Michigan Ave at Greenfield Dearborn \$5 students \$10 \$30 adults (313) 565 2424

Cantata Academy

March Mysticism Concert 8 p.m. Saturday Sacred Heart of the Hills Catholic Church 3400 S Adams Auburn Hills Ralph Vaughan Williams *Five Mystical Songs for Choir* Rene Clausen's *Communion* Stephen Paulus *Embracing All* with instrumentalists from the Detroit Chamber Winds & Strings \$15 (\$12 seniors/students) \$15 at the door (248) 358 9868

Harmony x Four

Several Detroit area vocal jazz ensembles present a free concert 3 p.m. Sunday in Room F 110 of the MacKenzie Fine Arts Center at Henry Ford Community College 5101 Evergreen Dearborn

Chenille Sisters

Lights Camera call to Action red carpet evening of Hollywood glitz glam and music 7 p.m. Thursday April 1 at the Farmington Civic Theater Benefits The Farmington/Farmington Hills Action Coalition \$20 VIP reception reserved seating \$100 (248) 489 3408 www.calltoactioninfo

WORLD/FOLK

Bellydance Superstars

7 p.m. and 10 p.m. Saturday The Magic Bag 22920 Woodward Ave Ferndale \$20 available at the Magic Bag box office 10 a.m. to 5 p.m. Monday Friday or Ticketmaster call (248) 645 6666 www.bellydancesuperstars.com

Belly dance workshops

Noon to 5 p.m. and 12 30 4 p.m. Sunday The Community House 380 S Bates Birmingham \$50 for each workshop Register in advance online at www.bellydancesuperstars.com Registration also available at the door

Belly dancing

Heat Night Club 2 N Saginaw Pontiac two blocks south of M 59 every other Saturday Next session April 3 Belly dance lessons at 9 p.m. followed by evening of dance Proper attire 21 & over cost women \$5 and men \$10 For those 18 20 years old admission is \$20 for men and \$10 for women (248) 322 5550

The Ark

Kalman Balogh Gypsy Cimboim Band & Friends 8 p.m. today Vince Gilbert 8 p.m. Friday Susan Werner 8 p.m. Saturday Joan Baez 7 30 p.m. Sunday Mountain Heart 8 p.m. Tuesday March 30 Solas 8 p.m. Wednesday March 31 316 S Main St Ann Arbor (734) 761 1451 www.a2ark.org

DANCE

Wayne State Dance

Seventy five year anniversary celebration weekend Friday Sunday dance concert 8 p.m. Friday Saturday Bonstelle Theatre 3424 Woodward Ave Detroit Diamond Anniversary Alumni Concert 3 p.m. Sunday Bonstelle Theatre www.dance.wayne.edu or call (313) 577 4273

More Dances

Contemporary Dance Company Michigan Choreographer Showcase 8 p.m. Saturday April 2 Azar's Gallery 670 Old Woodward Ave Birmingham Tickets \$15 adults \$10 students at the door (248) 689 4084

Country Western Dance

Hosted by Blackberry Creek Dancers on Saturday at the Italian Cultural Center 28111 Imperial Dr Warren Doors open 7 p.m. lesson at 7 30 p.m. open dancing 8 11 30 p.m. for couples line dancing and flow \$10 includes lesson snacks coffee & soft drinks (313) 526 9432



The 'World Famous' Lipizzaner Stallions present 'Dancing White Stallions' 2 p.m. and 6 p.m. Sunday at The Palace of Auburn Hills Tickets \$22 and \$27, discount for children 12 and under and seniors Call (248) 645-6666 or www.palacenet.com

Moondusters

Moondusters will host ballroom dancing to live bands featuring popular swing fox trot waltz cha cha and others 8 30 11 30 p.m. every Saturday \$6 dressy attire Singles and married Meet at the Livonia Civic Center 15218 Farmington Road and Five Mile Livonia Ballroom dance lessons 7 8 p.m. Saturday call Joe (248) 968 5197

COMEDY

Joey's Comedy Club

Mark Knope 8 15 & 10 45 p.m. Friday Saturday \$12 7 p.m. Sunday \$8 dinner show option available at Paisano's 5070 Schaefer Dearborn (313) 584 8885 www.joeyscomey.com or www.paisano1.com

Ann Arbor Comedy Showcase

Jimmy Dore 8 p.m. Thursday 8 p.m. & 10 30 p.m. Friday Saturday 314 E Liberty Ann Arbor discount for tickets purchased in advance (734) 996 9080

Mark Ridley Comedy Castle

Mike Birbiglia 8 p.m. Thursday \$6 8 p.m. & 10 30 p.m. Friday \$12 8 p.m. & 10 30 p.m. Saturday \$15 269 E Fourth Royal Oak (248) 542 9900

Chaplin's

Jeff Dunham 8 30 p.m. & 10 30 p.m. Friday Saturday Lord Carret 8 30 p.m. Wednesday Thursday March 31 April 1 8 30 p.m. & 10 30 p.m. Friday Saturday April 2 3 34244 Grosebeck Clinton Township south of 15 Mile Road Clinton Township (586) 792 1902 www.chaplincomedyclub.com 21 and over

Second City Detroit

Ten 8 p.m. Wednesday Thursday (\$15) 7 30 p.m. and 10 p.m. Friday Saturday (\$20) Best of the Second City Touring Company at 7 p.m. Sunday (\$12) 2301 Woodward Ave Detroit (313) 965 2222 Dinner show packages available Call for information

FILM

Redford Theatre

An American in Paris 8 p.m. Friday Saturday April 2 3 organ overture 7 30 p.m. 2 p.m. Saturday organ overture 1 30 p.m. 17360 Lahser Road Detroit (313) 537 2560 www.redfordtheatre.com

Uptown Birmingham 8

Classic Film Series 11 10 a.m. 11 0 p.m. 3 15 p.m. 5 15 p.m. 7 20 p.m. and 9 30 p.m. every Wednesday 211 S Old Woodward Ave Birmingham \$5 50 (248) 644 FILM

Detroit Film Theatre

Through May 24 Films are at 7 p.m. and 9 30 p.m. Friday Saturday 4 p.m. and 7 p.m. Sunday and 7 30 p.m. Monday except for special events Detroit Institute of Arts (theater in back of building) 5200 Woodward Ave Detroit adults \$6 50 senior citizens full time students with valid ID and DIA members \$5 50 (313) 833 3237 or www.dia.org/dft Discount tickets available in book of five for \$25

Film Wrap

With Ray MacDonald the last Friday of each month 9 11 p.m. at the Scarab Club 217 Farnsworth Detroit Discussion of the month's film showing at the Detroit Film Theatre Donation \$5, (313) 831 1250

MUSEUMS, PARKS AND TOURS

The Henry Ford

Quilting Genius an exhibition of more than 30 quilts Through Sunday May 9 Museum hours are 9 a.m. to 5 p.m. Monday Saturday noon to 5 p.m. Sunday Village Road at Oakwood west of the Southfield Freeway and south of Michigan Avenue Dearborn Adults \$14 seniors \$13 kids age 5 12 \$10 children under age 5 free call (313) 982 6001 or visit www.thehenryford.org

Cranbrook Institute of Science

Chimpanzee Challenge through May 10 a.m. to 5 p.m. Saturday Thursday until 10 p.m. on Friday (877) 462 7262 or www.cranbrook.edu 39221 Woodward Ave Bloomfield Hills no charge with museum admission \$7 adults \$5 children ages 2 12 and senior citizens Donate an old wireless phone to receive free admission Phones will be given to protect victims of domestic violence

The New Detroit Science Institute

Traveling exhibition MarsQuest admission \$2 adults \$1 children ages 2 12 with purchase of general admission to the Science Center - \$7 adults \$6 children ages 2 12 and seniors Admission to the IMAX Dome Theatre or Dassault Systemes Planetarium \$4 (313) 577 8400 or www.detroitssciencecenter.org www.marsquestonline.org

Detroit Zoo/Belle Isle Aquarium

Open 10 a.m. to 4 p.m. Wednesday Sunday through end of March Wild Winter activities every Saturday in March for information about programs visit www.detroitzoo.org

Ann Arbor Hands On Museum

Celebrating 20 years of discovery museum offers more than 250 science and technology exhibits to explore the world

of science 220 E Ann 10 a.m. to 5 p.m. Monday Saturday noon to 5 p.m. Sunday \$7 \$5 children students and seniors (734) 995 KIDS or www.laahom.org

CLUBS/BARS

Sevin The Nightclub

Sevin 40 W Pike St Pontiac (248) 745 7461 www.sevinthenightclub.com Hours are 9 p.m. to 2 a.m. Wednesday Friday and Saturday Ranges from \$5 to \$20 no charge for ladies excluding special events and holidays

George & Harry's Blues Cafe

George & Harry's 22048 Michigan Ave Dearborn Call (313) 359 2799 Friday and Saturday shows begin at 10 30 p.m. Weekday shows begin at 9 p.m.

Club Bart

22726 Woodward Ferndale All shows at 10 p.m. Ongoing Thursdays and Sundays comedy night and Fridays and Saturdays EvenExchange (Motown R & B and Jazz) Call (248) 548 8746

Mephisto's

2764 Florian Avenue Want a taste of the music at Mephisto's? Visit its entertaining Web site www.mephistosdetroit.com While surfing you'll dance in your seat to the heavy techno beat repeating here we go Mephisto's is close to both I 75 (off Caniff) and I 94 in Hamtramck (off Mt Elliott) This 21 & over club where proper attire is mandatory is new to our ever changing club scene and features three levels including a VIP lounge and terrace Hours Thursday Friday and Saturday 7 p.m. to 2 a.m. (313) 875 3627

Reggae

Tropical Hut Lounge 14925 Livernois Detroit near Fenkell This is not one of those suburban nightclubs that pretend to be an island style bar with fake grass and palm It's one of Detroit's truly authentic Reggae/roots clubs that attracts the city's island born residents Wednesdays Ladies Night Thursdays Reggae Night Fridays Friday Surprise Saturdays African Night Sundays Fun Sundays Open 4 9 p.m. Tuesday Wednesday 4 p.m. to 2 30 a.m. Thursday Saturday 5 p.m. to midnight Sunday (313) 861 5340

Majestic Theatre

4140 Woodward Ave Detroit Parking available on street and behind building It seems that every blues underground industrial punk reggae world and Americana band has played here Buju Banton and Burning Spear played here as did Social Distortion's Mike Ness Attire is freestyle casual and up Call for hours (313) 833 9700

Paradox Cafe

1927 Michigan Ave Detroit at the corner of Rosa Parks Blvd Metro Detroit's friendly Latin residents gather here for salsa dancing to DJs and live music Women wear dresses and high heels and men wear suits or flamboyant club wear Strict dress code no jeans or tennis shoes This is the place where couples dance Fridays are occasionally world music night and the Latin music is on Saturdays Valet parking is available Call for hours (313) 313 268 2325

Are you game?

Be a singing, dancing superstar at MGM Casino

Do you want to be in the spotlight on stage as singing superstar or show off your latest dance moves? You can do both at MGM Grand Detroit Casino's Stage Bar

Karaoke Night is 7 p.m. Tuesday with special guest host Dal Bouey. You can give the performance of your life as you sing your favorite Aretha Franklin tune or belt out your favorite rock ballad. MGM

Grand has all the favorites that make you feel like a star

Get out on the dance floor beginning at 11 p.m. Friday as Dante "DJ Te" Ellis spins all the latest dance tunes including Top 40, Techno, House, Hip Hop and R&B

The Stage Bar was recently remodeled. All guests must be age 21 and older. For more information, call MGM Grand

Detroit Casino at (877) 888-2121. For more information visit <http://www.mgm-mirage.com>

To get to the casino take I-94 east to M-10 South, exit left at Bagley Avenue. Turn right on Third Street.

This week's entertainment schedule also features Altamease Nelson at 5:30 p.m. and Alena at 10 p.m. today, Kaleidoscope at 5:30 p.m. Friday, JD Horizon at 1:15 p.m., Dal Bouey at 5:30 p.m. and the Mylestones at 10 p.m. Saturday, Taylor Made at 3 p.m. and the Paris Band at 7:30 p.m. Sunday

Green Eyed Soul plays at 5:30 p.m. Monday and Dal Bouey at 10 p.m. On Wednesday, March 31, catch Green Eyed Soul at 5:30 p.m. and Norma Jean Bell at 10 p.m.

MGM Grand Detroit Casino is a

75,000-square-foot gaming facility with more than 2,500 slot machines and 80 gaming tables including black jack, craps, roulette, baccarat, mini baccarat, 3-card poker, Caribbean Stud Poker, Let it Ride, Pai Gow Poker, Spanish 21, Super Fun 21 and Casino War

It offers world-class dining at The Hollywood Brown Derby, the MGM Grand Buffet with food selections from around the world, Lion's Roar Sports Bar and Grill, featuring casual dining where you can catch a sporting event on TV, and Java Coast Grill, offering hamburgers, made-to-order deli sandwiches and pizza, a selection of Asian foods, breakfast items and specialty coffee drinks

Grand Buffet menu promotions include fish fries starting at 4 p.m. Fridays and steak at 4 p.m. Saturdays

The Theatre Company

at University of Detroit Mercy

presents

The Robber Bridegroom

March 18 - April 4, 2004

Call today for reservations
313 993-6461

Mention The Observer & Eccentric Filter at the box office to receive a 2 for 1* ticket special

PDF0E08 9 273

ONLY MICHIGAN APPEARANCE!

Love and lust collide in Mark Diamond's dark, intensely powerful ballet inspired by the Tennessee Williams play. Blanche Dubois tries to preserve her beautiful but dreamlike world of the past in the brash and decadent atmosphere of New Orleans in the 1950s. The exciting score includes jazz, as well as contemporary and classical music.

A Streetcar Named

Desire

North Carolina Dance Theatre



4 DAYS ONLY!

April 1-4

AT THE DETROIT OPERA HOUSE

THURS	APR 1	7:30 P.M.
FRI	APR 2	8:00 P.M.
SAT	APR 3	8:00 P.M.
SUN	APR 4	2:00 P.M.

DETROIT
OPERA
HOUSE

Home of Michigan Opera Theatre

Phone (313) 237-SING

or visit www.michiganopera.org

FOR GROUP SALES PHONE: (313) 237-3409

DAIMLERCHRYSLER

DaimlerChrysler Corporation Fund
2004 SPRING DANCE SERIES

CAPTURES THE ENERGY OF ITS NATIVE LAND THAT IS PURE SENSATION!

•BREATHTAKING DANCE! • MUSIC! • ACROBATICS! • STORYTELLING!



LES BALLETS AFRICAINS

THE NATIONAL DANCE COMPANY OF THE REPUBLIC OF GUINEA
ONE PERFORMANCE ONLY! TICKETS AS LOW AS \$23

SAT. MARCH 27 8:00 P.M.

PDF0E08197848

Phone (313) 237-SING

or visit www.michiganopera.org

FOR GROUP SALES PHONE: (313) 237-3409

DETROIT
OPERA
HOUSE

Home of Michigan Opera Theatre

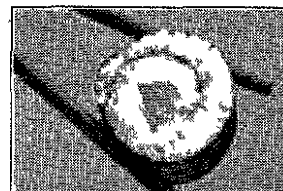

Find your favorite recipes each
Thursday in Taste

Horoscope



Star Struck

(March 25 - March 27)
By Dennis Fairchild

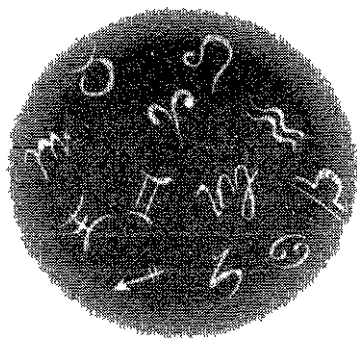

ARIES (March 21-April 20)

Try not to be too hard on yourself. Everyone makes mistakes, even an Aries, and the bigger the mistakes you make, the more of an opportunity you have of turning them into something of value. If mistakes are the way we learn, you'll learn something this week.

TAURUS (April 21-May 21)

You are justly renowned for being a patient, good listener, but now it's time to speak up and let others know your feelings and desires and upsets. You may not tell people what they want to hear, but at least they will know where you stand. Bull. Be brave, don't brood.

GEMINI (May 22-June 21)

Your way with words opens many doors, but sometimes leads to them being slammed in your face, and that's something you'll have to watch for this week. The Moon in your sign says that being brutally honest isn't always the best idea now, especially if your progress depends on it.

CANCER (June 22-July 23)

You may feel tempted to break with routine and do something completely out of character this weekend. After all, it's been a yawner of a month, eh? If you have the support of a certain key person, all the better. If not, be prepared to stick your neck out and do it anyway.

LEO (July 24-Aug. 23)

What is important to you now, especially on a material level, won't be so important to you by this time next week. That's good, because it's time you recognized that some things, and some people, are not to be taken seriously. Slow down, don't push yourself. Lion!

VIRGO (Aug. 24-Sept. 23)

Count to 10 and take action, Virgo! For too long, you've put off dealing with something of an emotional nature, but what happens this week will convince you that you can't run forever. Most likely, you'll discover that what you feared was a product of your imagination.

LIBRA (Sept. 24-Oct. 23)

Librans are great ones wishing they could turn back the clock and make things right. You can't, of course, but what you can do now is visualize a time and place in the future when the mistakes of the past no longer matter. Focus on life's possibilities instead of its perils.

SCORPIO (Oct. 24-Nov. 22)

The great thing to remember is that you are no longer tied to the past, nor are you under others' control or influence. In fact, the key word now is freedom. Therefore, think of the larger self that is limitless in power and possibilities, and spring will be a time of remarkable achievements.

SAGITTARIUS (Nov. 23-Dec. 21)

March is rarely an easy month for Sages because the Sun is at right angles to the position it occupied on the day you were born. But remember, adversity breeds opportunity, and you are unlikely to get a better chance to prove how cooperative, caring, and courageous you can be.

CAPRICORN (Dec. 22-Jan. 21)

Star wise, this could be a fortunate week for you, especially if you're ambitious and want to move up in the world. The only danger is that in your haste to succeed, you might go against your own principles and do something that hurts others, if only indirectly.

AQUARIUS (Jan. 22-Feb. 19)

For someone who is supposed to be easygoing, tolerant, and compassionate, you appear to be going in all directions at the moment. Just ensure you don't spoil what could be a perfect relationship or profitable alliance by insisting that everyone take your word as gospel.

PISCES (Feb. 20-March 20)

Don't forget that the only constant in astrology, as in life, is change. So make the most of current aspects to get your life moving in the right direction again. Mars soon entering your solar fourth sector signifies that you are in the ideal position to force the pace on the work front.

Dennis Fairchild is a Birmingham-based astrologer and author of several books on divination. For information about personal consultations, phone (248) 646-3555 or e-mail DenFairchild@aol.com.

Pure Picks

Selected from the reams of publicity propaganda we present our top entertainment picks for the week. Filtered just for you.



Old Time Relijun screams the way to a revolution.

Show

A little music lesson so we are all on the same page when it comes to the rarely used phrase "No Wave." Ahem. Two genres were created in reaction to Punk Rock: New Wave and No Wave. New Wave, the genre with which most every one is familiar, created everything from synthpop greats Depeche Mode to that *Tainted Love* song now playing in every car commercial these days. No Wave was the arty, experimental and provocative reaction to Punk Rock aesthetics, centered around New York's Lower East Side in the early 1980s. No Wave began with people like Lydia Lunch and Model Citizens, while bands like Sonic Youth and The Birthday Party keep it alive today. I hope you paid attention, because with this knowledge, you will be able to hobnob with the most elitist of music nerds at the Old Time Relijun. Piranhas and Human Eye show April 1 at the Detroit Art Space.

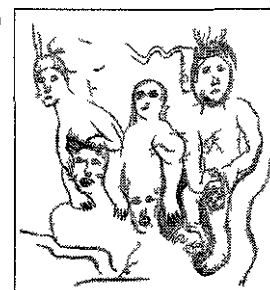

'Lost Light'

Old Time Relijun plays No Wave cacophony with a pagan influence. Stark, upright bass notes blend with sparse guitar plunking and garage rock drumming. Their new album *Lost Light* hits record stores on April 6. Joining the band will be Detroit punk institution **The Piranhas** and ex Clone Defects members, now calling themselves **Human Eye**. Cost is \$7. Doors open at 9 p.m. The Detroit Art Space is located at 101 E. Baltimore in Detroit. For more info, call (313) 664-0445.

Music

Cute/catchy singer/songwriter **Ben Kweller** will deliver his new CD *On my Way* on April 6. Get a sneak peek at the new record's material when Kweller plays Tuesday at the Royal Oak Music Theatre with underground greats **Death Cab for Cutie**. Singing about everything from his cats to heartache, Kweller



Sadly, he's married now. Singer/songwriter Ben Kweller.

powerpops a perfect mix of deephearted subjects and silly refrains, making music that is sincere and touching. And of course, Death Cab for Cutie basically invented sincere and touching. Make sure to prepare for a feast of nostalgia. Tickets are \$15 for the standing room only venue. Doors open at 6 p.m. with music set to begin at 7 p.m. Royal Oak Music Theatre is located at 318 W. 4th St. in Royal Oak. For tickets, call Ticketmaster at (248) 645-6666 or log onto <http://www.ticketmaster.com>.



Death Cab for Cutie members search for lost loves.

Pure Picks is written by Stephanie Tardy. She is always looking for new local bands and musicians. Send her your demos and Web site links! Know of something else you would like considered for this space? To submit information on local entertainment, films, clubs, restaurants or other ideas to be featured in this column, e-mail stardy@oe.homecomm.net or write to her at 805 E. Maple, Birmingham, MI 48009.

Web Site

Tear yourself away from *YM's Say Anything* or *Cosmo's Confessions* columns for a minute and take your cheating heart over to **Group Hug** (<http://grouphug.us>). The site provides an anonymous confessions board, allowing users to air their deepest secrets and embarrassments in a confidential and public arena. (Man, don't you just love the Internet?)

As of Tuesday, there were 63,628 active confessions, all designed to say "My life isn't as bad as that guy's," and "See, our combined human experience does involve tripping up stairs and farting at work." A small warning: Although the site bans gratuitous vulgarity, many of the topics may not be suitable for children's eyes.

Free

I believe in a thing called free in-store appearances. The tongue-in-cheek rockers **The Darkness** will meet fans and sign copies of their album *Permission to Land* at 1 p.m. March 28 at Tower Records in Birmingham. Tower Records is located at 202 N. Old Woodward Ave. For more info, call (248) 647-1707.

Party time

Fanclub wants to create fans of art

It was probably the first time some of the students at Most Holy Trinity Elementary had ever seen the Detroit Institute of Arts

"Mrs. H, you show us beauty!" they told their teacher, Carla Haska, during one such visit.

When she tells the story, there's an audible sense of admiration and joy in Haska's voice

As art teacher at the parochial school in Detroit, she knows first-hand the effect the arts can have on young minds

I've seen kids do a complete 360. When you tell them they can do anything, it's incredible how you can see their artistic talent evolve," Haska says. "It just builds their ego and their self-esteem."

It wasn't always like this, there was a time a few years back when paper to draw on was scarce, let alone trips to the DIA. State funding cuts have led most schools to slash arts programs, and Holy Trinity Elementary was no exception.

Enter Fanclub Arts Foundation, a non-profit organization that grants funds to create or support arts education in low- and middle-income areas.

Holy Trinity has been receiving grants from Fanclub for two years, and it's not

SWINGTIME '04

What: A fund raiser to benefit Fanclub arts foundation, which grants funds for arts education in low- and middle-income areas

When: 7:30-11 p.m. Saturday April 3

Where: The Fisher Building in Detroit

Tickets: \$100 per person (248) 584-4150

hard to notice a change at the school.

"They have helped us," said Haska, who also acts as the school's gym teacher and its marketing/development coordinator. "Having no art program, they have definitely expanded our horizons."

"(Arts education) always seems to be the first thing to go when there are budget cuts (to schools)," said Allison Jewett, director of events for Fanclub.

The foundation began more than a decade ago, a pet project of arts lover and Bloomfield Hills resident John Bloom. Since its inception, Fanclub has granted

more than \$400,000 to area schools and organizations.

Fanclub is sustained through individual and corporate donations, and fund raisers like the upcoming Swingtime '04 at the Fisher Building April 3.

For \$100 per person, attendees will get to belly up to a premium open bar, munch on gourmet nibbles from about 24 local restaurants and dance to music from Alma Smith, the Twistin' Tarantulas, Intrigue and Rhythm Society Orchestra.

Jewett said the organization hopes to raise about \$60,000 from the event, which is capped to include 1,000 people this year. Bloomfield Hills resident Heidi Stem of Heidi's Salons fame is chairing this year's event.

That's \$60,000 that Fanclub can give to low-income schools like Holy Trinity, which stresses the importance of arts education.

"(Principal Kathleen McBride) understands how important (art) is to a child's development," said Haska, who notes that many people are quick to write art education off as a frivolous expenditure.

"Every aspect of life is art, right down to the clothes that are made for you. It's so much more than coloring pictures."

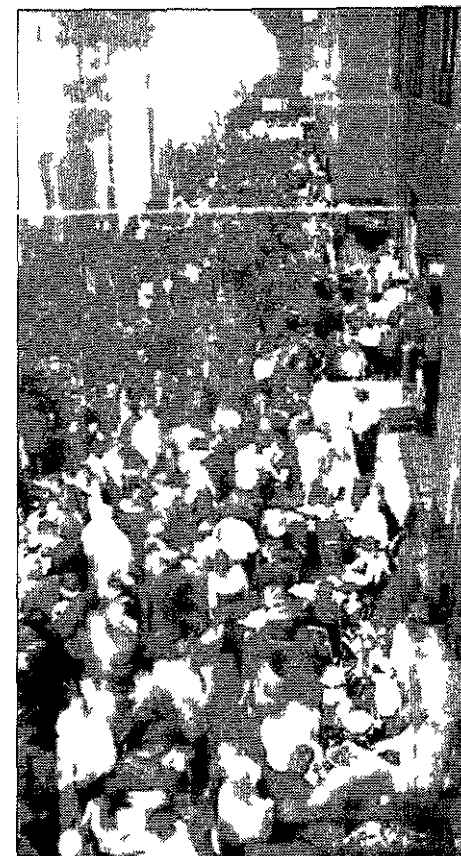

Last year's Swingtime event drew more than a 1,000 people from around metro Detroit.

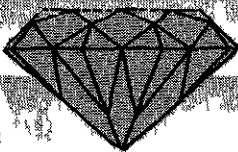

*Wholesale Prices
to the public*

PUBLIC NOTICE
Store Closing Sale

Diamonds

35241 Warren Rd.
Westland, MI 48185

(734) 595-7621

Fax (734) 595-7627

Up to **80%**
Savings

*Everything
Must Be Sold*

Total Wall to Wall Reduction

**Watches
50% Off**

✓ **14k Gold.....\$10.99 a gram**
Chains & Charms

✓ **Platinum at the lowest Price Ever....**
Hurry while supplies last!

All Major Credit Cards
Accepted

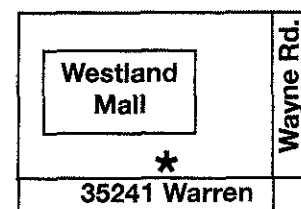
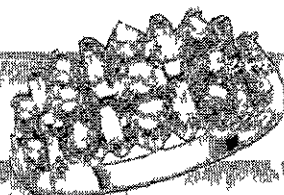

CE08188801

Contest

Winners talk about their heroes

Bruce Sharer, Nancy Serlin and Diane King are the winners of our *Miss Saigon* contest. They wrote about their hero to win a pair of tickets to the 8 p.m. performance of *Miss Saigon* today at the Fox Theatre.

Here are their stories.

My high school teacher Bob Lyon was a mentor and continues to be a friend to this day, wrote Sharer, a Rochester Hills resident.

I grew up in a typical blue collar, middle class working household and did not have much exposure to the arts. It was not until I took my first humanities course from Bob Lyon in my junior year that I had my real first taste of theater, film, music, art and dance. The two years I spent taking classes from Bob helped mold me into the person I am today. After high school I went to college and stayed in touch with Bob. After a couple of years, I reached a point in my college career where I was not doing real well in my chosen major and was suffering from college burnout. Bob told me that it was not important what I got my college degree in. His thought was to take whatever curriculum I liked best and get my degree. He said that with the degree in hand, 'Doors will open up for you.' Bob was sure right about that. I went back to college the next semester and ended up having a wonderful two years getting a degree in English literature. With that degree in hand, I got a job with a national firm and I am celebrating my 26th year with that company this year.

"My hero is my mom," wrote Serlin, a Farmington Hills resident. At 81 she runs circles around everyone including me. She is an actress in Lansing and will be in *Steel Magnolias* for the fourth time. She does commercials and has one running on TV as we speak. She raised three children and was very involved in their lives even as she volunteered with groups who raised money for all sorts of good causes. This is a salute to Leonor Reizen for being the best that she could be and passing it on.

"The hero in my life is my father, Mitchell Pawlak," wrote King, a Livonia resident. "He suffered through years of torture and savagery in the German concentration camps during World War II and managed to survive. He married my mother and brought me as an infant from Poland after the war to the U.S. to make a better life for his family."

He is a caring and wonderful man who always thought of his family first and himself second, and I will always consider him to be my hero.



Sugarloaf Art Fair®

April 16, 17, 18, 2004
Novi Expo Center
Novi, MI

300 Fine Artists & Craft Designers

Fri., Sat. & Sun. 10-6

Daily Adult Admission \$6

Children Under 12 FREE

Parking FREE Compliments of Sugarloaf

▷ **Craft Demonstrations**

▷ **Entertainment**

▷ **All Indoors** ▷ **Specialty Foods**

▷ **Free Shopping Bags**

▷ **Strollers Not Recommended**

▷ **No Pets Please**

Directions:

Take I-96 to Exit 162. Turn south on Novi Road. Turn right onto Expo Center Drive. The Expo Center is located one block on the right.

For Discount Admission Coupons:

▷ **Print them from our website at www.SugarloafCrafts.com**

▷ **Visit your local Farmer Jack**

▷ **Call 800-210-9900**

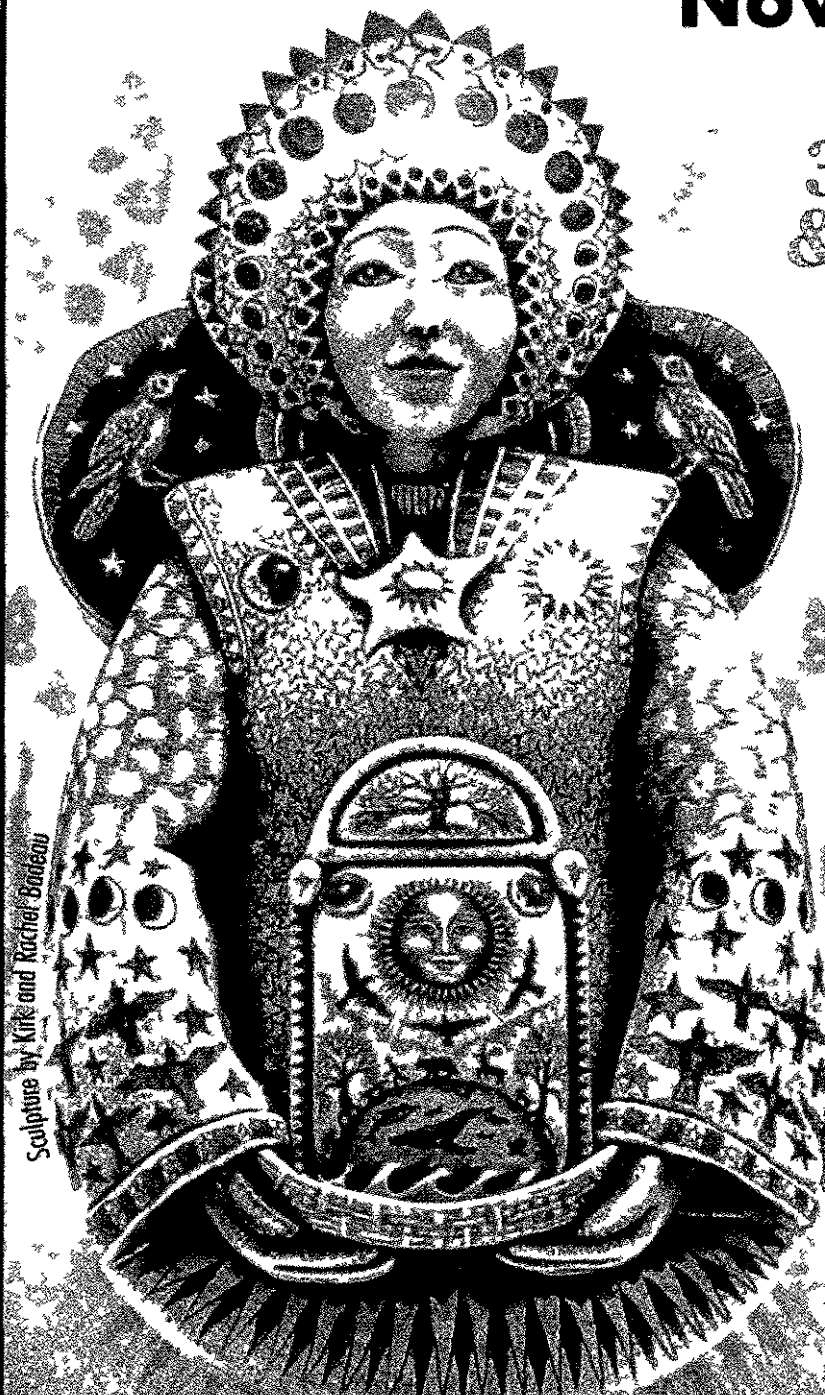

HOMETOWN Observer & Eccentric
NEWSPAPERS

Buy crafts online at www.CraftsOnline.com

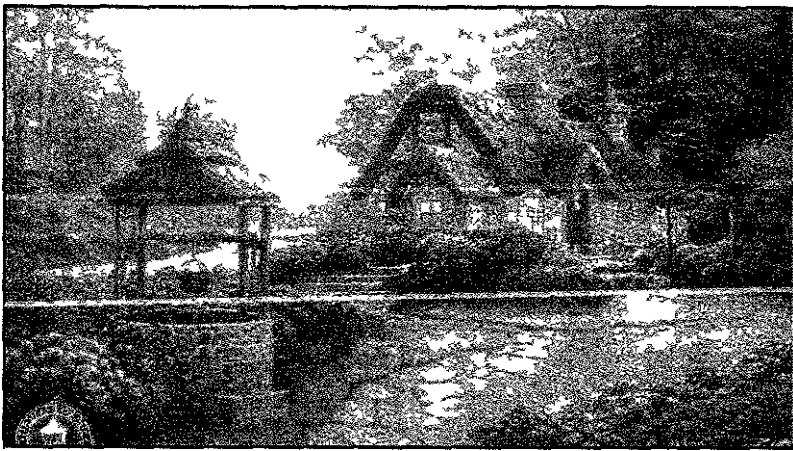

"Make a Wish Cottage" by Thomas Kinkade

Parkside Gallery is pleased to announce the hosting of a Thomas Kinkade Master Highlighting Event on Saturday and Sunday April 24th - 25th from 10 A.M. to 6 P.M.

Any limited edition canvas painting purchased or put in layaway by that date will qualify for this additional highlighting. Don't miss this great opportunity to add beauty and value to your painting!

We invite you to come in and view our extensive selection of Thomas Kinkade paintings.

Parkside
Gallery
ART & GIFTS
FORMERLY WILD WINGS

- ART ON APPROVAL •
- CONVENIENT LAYAWAY •
- CUSTOM FRAMING •
- OPEN 7 DAYS •

388 SOUTH MAIN
DOWNTOWN PLYMOUTH
800-755-3401

CE08197196

**THE HEAT
IS ON!**

**MIS S
Saigon**

**NOW - SUNDAY
FOX THEATRE**

GREAT SEATS STILL AVAILABLE!
At OlympicEntertainment.com, the Fox Theatre and Joe Louis Arena box offices, Hockeytown Authentics in Troy and all **ticketmaster** outlets including Marshall Field's and at Ticketmaster.com.
Charge by phone 248.433.1515

Presented by *Olympia* and *BACI*



THE DETROIT INSTITUTE OF ARTS



AMERICAN ATTITUDE

WHISTLER & HIS FOLLOWERS

MARCH 14 - JUNE 6, 2004

Some artists developed a style. Whistler developed a following. Featuring the painting "Whistler's Mother," an American icon.

TICKETS: 877-DIA-TIXS

www.dia.org/whistler

MEMBERS RECEIVE FREE TICKETS. JOIN TODAY!

313/833-7971

James McNeill Whistler, Arrangement in Gray and Black, No. 1 (Whistler's Mother), c. 1871. Oil on canvas, 111.4 x 111.4 cm. The Detroit Institute of Arts, Detroit, Michigan. Photo: Stuart Holm for the Musée d'Art Moderne et d'Art Contemporain, Paris.

This exhibition was organized by The Whistler Society and the Institute of American Artists, in collaboration with The High Museum of Art, Atlanta, with generous support provided by the Henry Ford Foundation and the National Endowment for the Arts. In Detroit, the exhibition is supported by the Comerica Charitable Foundation, Kenwal Steel Corp., the Michigan Council for Arts and Cultural Affairs, and the City of Detroit.

Comerica
Charitable Foundation

Kenwal

PDF 0808197829