

Board OKs 18 teacher layoffs

BY TONY BRUSCATO
STAFF WRITER
tbruscato@oe.homecomm.net

The Plymouth-Canton Board of Education voted 5-1 Tuesday to lay off 18 teachers, with the hope of calling them back before school begins in August.

The number is one less than had been reported earlier. District officials said one teacher stepped forward to announce a retirement, allowing for the call-back of an educator on the lay-off list.

"Leaves of absences, teachers exercis-

ing their rights to go from half time to full time, and a very small retirement pool this year has created a surplus of teachers," said Ray Bihun, executive director for human resources. "I know we're going to have more retirements, I just don't know when."

Trustee Judy Mardigian voted against the layoffs, saying she wanted more time to look at alternatives.

"The board needs to have a budget workshop. Waiting until May 21 is too late," said Mardigian to her fellow board members. "I would like to have more opportunity to look at alterna-

tives."

Superintendent Kathleen Booher said the layoffs "are not premature, and they are not irreversible. As our information gets clearer, we will call teachers back immediately upon knowing a position opens."

A total of 32 teachers were given notices last week, indicating they will either be moved to an assignment in another building or be laid off. The administration, according to the contract with the Plymouth-Canton Education Association, must notify teachers of layoffs at least 60 days before the

school year ends. Bihun said the layoffs will affect 14 K-12 teachers, and four English as a Second Language teachers at Starkweather Education Center.

"There's no way we can present the budget to the board for next year with out modest layoffs in employees. We don't see any way around it," said Booher.

Booher added the 2002-2003 budget is a difficult one, considering the \$200 increase in the state foundation

Please see LAYOFFS, A4



Praise Mom with a poem

Celebrate your mother with a poem and win a prize for her courtesy of the Observer Newspapers. We're inviting our young readers 18 and under, to submit a poem in praise of their mother. The poem can take any form from haiku to sonnet to free verse. A panel of judges will select their favorite.

Seven winning poets will win a gift for mom. The prizes include an 11 by 14-inch portrait for up to 14 people from Focal Point Photography in Farmington and Canton (sitting fee is included), \$100 gift certificate to Ernesto's Restaurant in Plymouth Township, \$100 gift certificate to Antonio's Italian Cucina in Farmington Hills, \$100 gift certificate to Sandtraps in Livonia, and more.

We'll publish the winning entry and other entries on Mother's Day. Entries are due to The Observer by Monday, May 6.

Send entries to Mother's Day Contest, Observer Newspapers, 36251 Schoolcraft, Livonia, MI 48150, or fax to (734)591-7279 or e-mail to hgallagher@oe.homecomm.net.

IN THE PAPER TODAY

Film Fest: David Magidson's It Happened Here is one of many films being shown during the fourth annual Lenore Marwil Jewish Film Festival. /B1

HOMETOWN LIFE

The first: Men and woman toning up with one idea in mind - to walk 60 miles in the Avon Breast Cancer 3-Day. /C5

INDEX

- Apartments/F4
- Arts/B1
- At Home/C1
- Automotive/F5
- Classified/E,F,G,H
- Classified Index/E5
- Crossword/F3
- HomeTown Life/C5
- Jobs/G1
- Obituaries/A5
- Real Estate/E1
- Service Guide/G6
- Sports/D1

WOODWORKING TOOLS Reasonable

I got alot of calls from this ad O.K. Plymouth

HOMETOWN CLASSIFIEDS WORKS

1-800-579-SELL



6 53174 10008 5

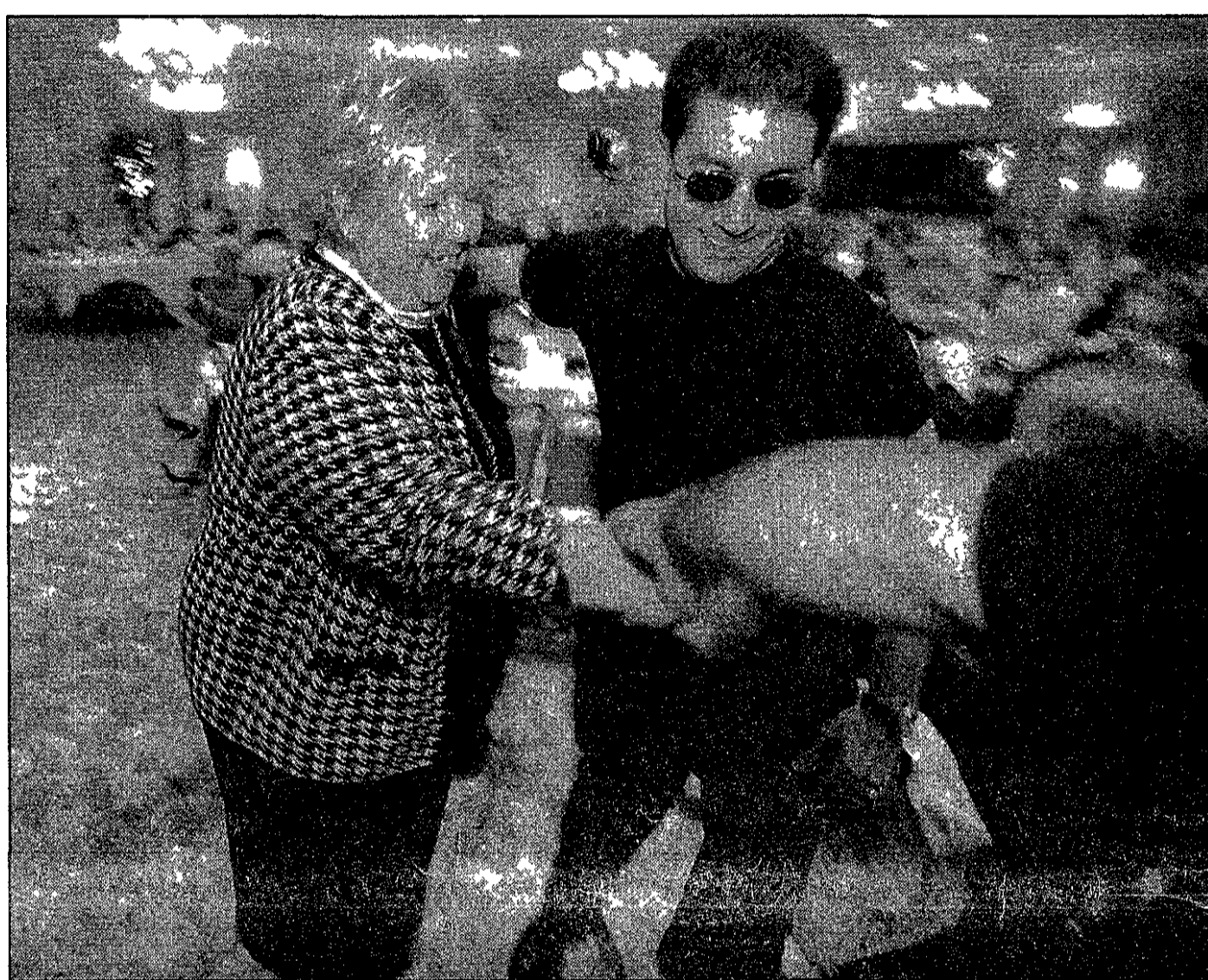

Come along: Man in Black Rob Costanza leads Fran Toney, executive director of the Plymouth Community Chamber of Commerce, to the stage during Wednesday's luncheon.

STAFF PHOTOS BY BRYAN MITCHELL

Dance fever

Lunch honors administrative professionals

BY BRAD KADRICH
STAFF WRITER
bkadrich@oe.homecomm.net

As the Men in Black disbanded Wednesday, dance mentor Joanne Zavisa noted, "You guys are getting too good."

That's probably not true, but it was a nice sentiment as the dance troupe ended its third straight Administrative Professionals Day luncheon performance at Plymouth Manor. The event, sponsored by the Plymouth Community Chamber of Commerce, honored 70 administrative professionals from the area.

Denise Barackman, the officer manager for Graphic Visions of Northville, was honored as "Assistant of the Day." Door prizes went to a variety of people. Guest speaker was Camille Procassini.

"These professionals work very hard and do a great job," said Fran



Toney, executive director of the chamber. "It's a pleasure to honor them."

Following Procassini's speech and presentation of some of the prizes, the Men in Black made their appearance. The group featured Rob Costanza of Station 885, Mark Kramer of Soil & Materials Engineers, Brian

Dance fever: The Men in Black lead the audience in a stirring rendition of "YMCA" at the end of Wednesday's Administrative Professionals Day luncheon at Plymouth Manor.

Mamo of Standard Federal Bank, Kelly Mikoloff of Plymouth Carpet Service, Denny Pennington of Westchester Square, and former city police chief Robert Scoggins.

Zavisa, owner of Joanne's Dance Extension, choreographed the three-minute performance.

Former administrator, engineer vie for board

BY TONY BRUSCATO
STAFF WRITER
tbruscato@oe.homecomm.net



Carol Saunders

"Education has been my life, it's important to me," said Saunders, 63, of Plymouth Township, and the former adult education coordinator for the Starkweather Education Center. "I want to make sure people in Plymouth-

Canton have the opportunity to have excellent educational advantages."

Saunders said she's concerned about several problems facing Plymouth-Canton schools, and wants to be part of the solution.

"Funding, that's no surprise," said Saunders. "Many thought Proposal A was the end-all answer for equality funding in Michigan, and we've found out it isn't. We need to tweak it."

"I also believe we need to be able to hold a millage election," added Saunders. "I don't know if it would be passed by voters, but right now we don't even have the possibility to enhance our funding through a millage



BY TONY BRUSCATO
STAFF WRITER
tbruscato@oe.homecomm.net

Robert Nelson believes there's a strong fit between the objectives of the Plymouth-Canton school district, and his interests in becoming a member of the Board of Education.

"Setting vision, financial oversight, making sure key people are in the right place. These are the things the

school board does, which are my interests and the interests of the community," said Nelson, 47, an engineering consultant from Canton. "I've worked with the schools and the kids since I moved into the area, and I want to see a good district become better."

As Nelson puts it, "This district is

facing some serious challenges financially. Over 85 percent of our budget is fixed, with 85 percent going out in salaries. That presents a huge challenge."

"Our largest expense is also our largest asset, the people in our schools," he said. "It's one of the things that makes people want to move to Plymouth-Canton. We have a highly talented, skilled and motivated staff, and I'm glad we're working with them on interest-based bargaining in an attempt to have a cooperative solution."

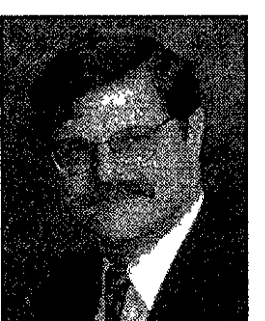

Robert Nelson

Please see NELSON, A7

Plymouth walk set for Westland's Nankin Mills

BY DOUG JOHNSON
STAFF WRITER

The WalkAmerica for the March of Dimes scheduled for the Plymouth area will really step off from the softball fields across from Nankin Mills Nature Center in Westland this Saturday.

It's called the Plymouth walk because it started at Haggerty and Hines Drive last year. The bridge work over the river had just started and it was too late to change the location, according to March of Dimes event coordinator Enna Whitted.

The charity is still calling it the "Plymouth" walk location, however.

This year's walk starts at 9 a.m. and will go from the Nankin Mills area to Haggerty Road through Livonia and back

(about eight miles round trip) along Hines Drive. Registration starts at 8 a.m.

Hines Drive will be shut down for the event.

Wayne County executive Edward McNamara is honorary chairman and will kick off the event at about 8:20 a.m. About 1,500 to 2,000 walkers are expected.

Checkpoints offering refreshments will be sponsored by Durr Industries, Comcast, Federal Express, Sprint and Kohl's. Panera Bread is running the VIP tent, and Rock Financial is sponsoring the registration tent. Home Depot is also helping as a sponsor.

"We are expecting several walk-ins and many people have already registered," Whitted said. "We are also dog-friendly, so people can bring their pets."

Other area walk sites include Troy, Metro Beach Metropark and Detroit, there are 43 sites state wide. The charity expects to raise \$3 million during the various local walks. Since 1970 the national group has raised \$1 billion with WalkAmerica. Walkers seek donations and pledges to raise funds during the walk.

The walk events raise funds to help families with babies born prematurely through life-saving research and innovative programs. Nearly 500,000 babies are born too soon every year according to the March of Dimes.

The four area walks are being operated by the Southeast Michigan Chapter of the March of Dimes in Southfield, phone (248) 359-1550 for information about their work or about joining the walk.

PLYMOUTH PIPELINE

Fall fest meeting

The Plymouth Fall Festival Committee conducts its next meeting at 7:30 p.m. Tuesday, April 30 in the Plymouth Township Clerk's office, located at the corner of Ann Arbor Road and Lilley.

Representatives of any community group that wants to get involved is being urged by committee officials to attend.

Questions can be directed to Mark Baldwin, (734) 455-1350.

Pompon tryouts

Tryout clinics for the 2002-2003 Plymouth Canton Chiefettes pompon squads are set for 5:30-8:30 p.m. May 13-15 in the Canton High School Phase III gymnasium.

Final auditions for potential squad members takes place at the same location from 4-9 p.m. Thursday, May 16. Tryout information packets are available in the offices of Canton High School and all middle schools.

A mandatory informational meeting for all potential Chiefettes and their parents takes place at 7:30 p.m. Monday, May 13 in the Canton choir room.

The Chiefettes took top honors at the Mid-American Pompon competitions, including grand champion honors at summer camp, second place in the high-kick dance competition and second at the statewide pompon competition.

Antique appraisal

Want to find out what your collectibles are worth? Here's your chance.

The Plymouth Historical Museum sponsors an antique appraisal clinic from 10 a.m.-5 p.m. Wednesday, May 8. The clinic features Antique Roadshow appraiser Ernest DuMouchelle. Cost is \$10 per item for an oral appraisal, \$15 for a written one.

Call the museum, (734) 455-8940 for an appointment.

Anniversary party

The Plymouth Community Chamber of Commerce is throwing itself a party, and hoping local people will join them in marking their 81st anniversary.

The party, set for 6:30 p.m. Friday, May 10, will honor the chamber's 50 years of incorporation with a black-tie-optional event at the Mayflower Meeting House.

Honorary chair of the event is John Thomas of Semphner, Thomas and Boak. The night kicks off with a champagne reception, with dinner served at 7:30 p.m.

Dancing to the music of the nine-piece band The Blue Notes follows dinner.

Tickets are \$50 per person, and seating is limited. For reservations or more information, call (734) 453-1540.

Legion open house

Beasley-Zalesny American Legion Post 112 hosts a two-day community open house to increase growth, community service and ability to assist veterans and their families in the Plymouth area.

The event will be held at the Odd Fellow Hall, at the corner of Ann Arbor Trail and Elizabeth, from 10 a.m.-7 p.m. Friday, April 26, and from 10 a.m.-5 p.m. Saturday, April 27. It's open to honorably discharged wartime veterans and their families are welcome.

A state Veterans Service Officer will be on hand to help with veterans benefits questions or claims. American Legion membership is over 93,000 statewide.

American Legion eligibility dates are: Persian Gulf, Aug. 2, 1990-cessation of hostilities, Panama, Dec. 20, 1989-Jan. 31, 1990; Grenada/Lebanon, Aug. 24, 1982-July 31, 1984; Vietnam, Feb. 28, 1961-May 7, 1975; Korea, June 25-1950-Jan. 31, 1955; World War II, Dec. 7, 1941-Dec. 31, 1946; World War I, April 6, 1917-Nov. 11, 1918.

Fourth Sundays

The Plymouth Historical Society sponsors a special lecture series on women during the Civil War as a complement to the new Abraham Lincoln Exhibit and the Civil War display at the museum.

The series, titled "Fourth Sundays at Two," begins at 2 p.m. Sunday, April 28. The first lecture features renowned Lincoln scholar and collector, Dr. Weldon Petz, talking about "Mary Todd Lincoln — Wife, Mother and First Lady."

The second part of the series takes place May 26 and features historian Robert Zaetta talking about "Women of the Civil War." The series concludes June 30 with costume historian and collector Pam Yockey talking about "Civil War Fashions."

Tea and scones will be featured after each program. Fee for each lecture is \$5, which includes a tour of the museum. Call (734) 455-8940 for details.

GRAND OPENING Sylvan Learning Center of Canton Open House April 26, 2002 3:00-6:00

Announcing the grand opening of a new Sylvan Learning Center. For more than 20 years, we've helped over a million children develop a love of learning. At Sylvan, students build the skills to do better in schools, and the confidence to do better in everything else. We get results through a proven process that works—the Sylvan Advantage™.

- We begin by identifying each child's specific needs, then we provide individual attention and personalized lesson plans.
- Sylvan teachers are highly trained and certified—and just love teaching.
- We keep you updated every step of the way with regularly scheduled conferences and progress reports.

If your child is struggling in school or just isn't being challenged enough, call Sylvan today.

\$25 OFF SYLVAN SKILLS ASSESSMENT*

Just bring this coupon to your scheduled appointment to save \$25 on the Sylvan Skills Assessment.

7752 CANTON CENTER ROAD
(734) 207-8888

Not valid with any other offer. Expires 6/30/02. Must present coupon at time of Assessment. Limit one per customer.

Sylvan Learning Center
7752 Canton Center Road
Canton, MI 48187
(734) 207-8888

READING MATH WRITING STUDY SKILLS SAT/PREP PREP

"May you always have a reason to celebrate, and someone to celebrate with."

BENNIGAN'S

Sláinte

42874 Woodward Ave.
Bloomfield Hills
(248) 334-9810

40441 Ann Arbor
Plymouth
(734) 459-8907

\$5.00 Off

\$20 Purchase

Bring this coupon to Bennigan's and receive \$5 off your food purchase of \$20 or more.

BENNIGAN'S
Sláinte

Valid on food and non-alcoholic beverage purchase of \$20 or more. Not valid on alcoholic beverages or in conjunction with any other special offer. Tax and tip not included. Limit one coupon per party per table per visit. Expires 5/10/02.

2 Burgers for \$10.99

Bring this coupon to Bennigan's and get 2 Tavern Burgers for only \$10.99.

(Excludes Big Irish Burger.)

BENNIGAN'S
Sláinte

Not valid in conjunction with any other special offer. Tax and tip not included. Limit one coupon per party per table per visit. Expires 5/10/02.

LET US PLANT FOR YOU!

Let our professional installers plant your tree for you. Ask our sales people for information.

BLUE SPRUCE
6 B&B REG \$249.00
\$50.00 OFF
With this Coupon One per customer (cost of labor is not discounted) 0E422302

JACKSON & PERKINS STAR
BOXED ROSES
starting at \$9.99
NOW \$3.00 OFF!
Patented
Non-patented
Romantic
David Austin

Country Crafts
ARBOR
48" x 80"
REG \$99.99
White wooden arbor with lattice uprights #2339 242
\$79.99

FAN TRELLIS
84" natural wood
REG \$29.99
\$24.99
#3724 006

Potted
CLEMATIS
\$5.99
Perennial Vine
Many varieties
many colors
REG \$7.99
#3850 532

Greenview 4-STEP
Lawn Fertilizer Program
4 bags 10,000 sq. ft. each
REG \$64.99
REG \$69.99
3950 007

HOME & GARDEN
SHOWPLACE
734-453-5500
www.plymouthnursery.net
EXTENDED SPRING HOURS:
Mon-Fri 8-8 • Sat 8-6 • Sun 10-6
OFFERS EXPIRE 5/1/02

PLYMOUTH NURSERY
and GARDEN CENTER
9900 Ann Arbor Rd./Plymouth Rd.
7 Miles West of I-275
1 1/2 Miles South of M-14
Corner of Gotfredson Rd.



Musical magic

Joint effort: *The Plymouth Symphony (below) plays for elementary students at Salem High School. It's part of a cooperative effort between the symphony and the schools to get youngsters involved in the music program. The annual joint concert took place at Salem High School. Plymouth-Canton students (left) get involved in the program.*

STAFF PHOTOS BY BRYAN MITCHELL

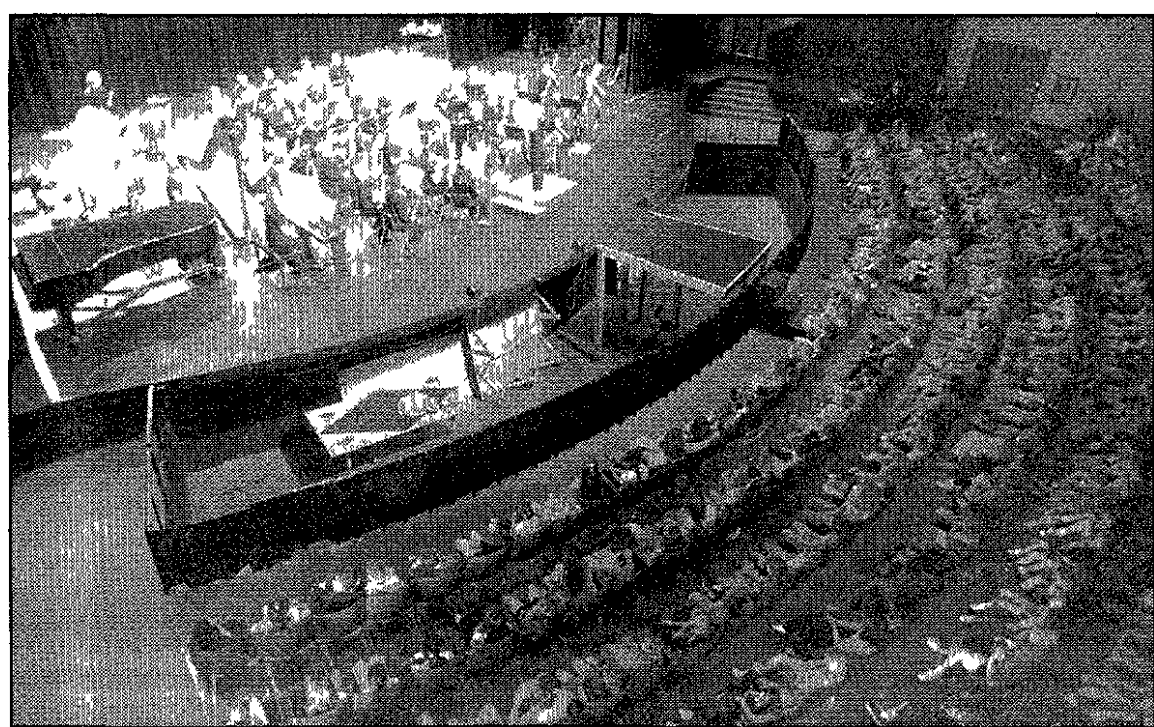

City cop sends letters, warning ticket scofflaws

BY TONY BRUSCATO
STAFF WRITER
tbruscato@oe.homecomm.net

For the past several years, getting a parking ticket in Plymouth meant nothing more than getting a piece of junk mail for hundreds of motorists.

However, that is expected to change as Police Chief Wayne Carroll has sent more than 700 letters to people who, over the course of several years, have failed to pay their parking tickets.

"We've been able to set up a list of individuals who are behind on their parking tickets, and have sent them a notice giv-

ing them a little time to come in and take care of their problem or it will be sent to 35th District Court," said Carroll. "They've already had their two-week grace period, plus some. Once we go through this initial phase, we'll see who doesn't respond and send them over to court."

Carroll estimates there is approximately \$10,000-\$14,000 in unpaid parking tickets. The average ticket is about \$15, plus a \$5 late fee.

Court Administrator Kerry Erdman says after the fine and late fee is assessed in Plymouth, there could be another \$25 late fee added by the court, as well as

a 20-percent statutory fee on top of that.

"And, if someone has six or more parking tickets, their driver's license could be suspended until they pay the fines," said Erdman.

Carroll admits it's taken a long time for his department, which has gone through several administrative changes over the past couple of years, to catch up with ticket scofflaws.

"Our priorities have been more in the manning of the streets and taking care of those kinds of problems," said Carroll. "Now, we're catching up."

Township approves treating roads

BY BRAD KADRICH
STAFF WRITER
bkadrich@oe.homecomm.net

Plymouth Township officials will once again provide calcium chloride on its dwindling number of unpaved roads.

The Plymouth Township board Tuesday approved spending up to \$15,000 to hire Wayne County contractors to provide the calcium chloride, used to dispel the dust on unpaved roads.

Contractors will chloride 5.85 miles of roads in various subdivisions.

■ **Tomlinson Estates (1.0 miles)** — Southworth Avenue and Gold Arbor Avenue

■ **Eastlawn subdivision (.6 miles)** — General, Eastside, Micol and Firwood drives

■ **Robinson subdivision (1.7 miles)** — Russell, Morgan, Brownell, Francis, Butternut, Gilbert, and Ferguson

■ **Plymouth Colony (.5 miles)** — Governor Bradford,

John Alden, Priscilla Lane and Turkey Run

■ **Plymouth Hills (.9 miles)** — Amherst Court and Nicholas Lane

■ **Plymouth Gardens (.3 miles)** — Parkhurst, Lakeland Court and Phoenix Court

■ **Finch (.3 miles)** — Lakeland Court and Finch

■ **Phoenix Park (.3 miles)** — Hammill and Garland avenues

■ **Hilltop Golf Course Drive (.25 miles)** — Beck Road east to the parking lot

It's the lowest total of chloride the township has done in at least nine years. In 2001, 6.15 miles of roads were treated, at a cost of nearly \$13,000.

In other action, the board

■ **Adopted a proclamation** honoring Clerk Marilyn Massnegill as part of Municipal Clerks Week. Township Supervisor Steve Mann drew a laugh, when

reading the proclamation, he read "The office is the oldest in municipal government." He stopped and said, "That's the office, not Marilyn," drawing a laugh from the dozen or so people in the audience.

■ **Adopted the by-laws** of the new Downtown Development Authority, and also conducted the first reading of the ordinance detailing the tax increment financing and development plan for the authority.

■ **Approved a \$24,000 amendment** to the contract with CTI to continue monitoring Fire Station #2, which is being monitored for a gasoline spill that took place years ago.

Township engineer Mike Bailey recommended the amendment to the contract, pointing out the only other real option was to do nothing, in which case the township could be subject to substantial fines from the state.

Jazz Ensembles to perform free concert

The Plymouth Canton Educational Park Jazz Ensembles I and II perform a free concert at the Penn Theatre in Plymouth at 7:30 p.m. Monday, May 6. The community is invited and a free will donation will be accepted.

The Jazz Ensembles under the direction of Clayton Wachholz, are currently seeking club

status at the park. The purpose of this free concert is to showcase the Jazz Program at PCEP and at the same time, invite the community to utilize the ensembles as entertainment for local events according to Lorraine Paffenroth of the Plymouth Canton Music Boosters.

"Ultimately, future concerts

will bring in guest jazz artists," she said. "We are grateful to Jim Courtney and John Mazza of the Penn Theatre Group for allowing us to rent the theater for this event."

For more information contact Clayton Wachholz at 416-2909 or Lorraine Paffenroth at 455-8213.

Wonderland Spring Fest

2002

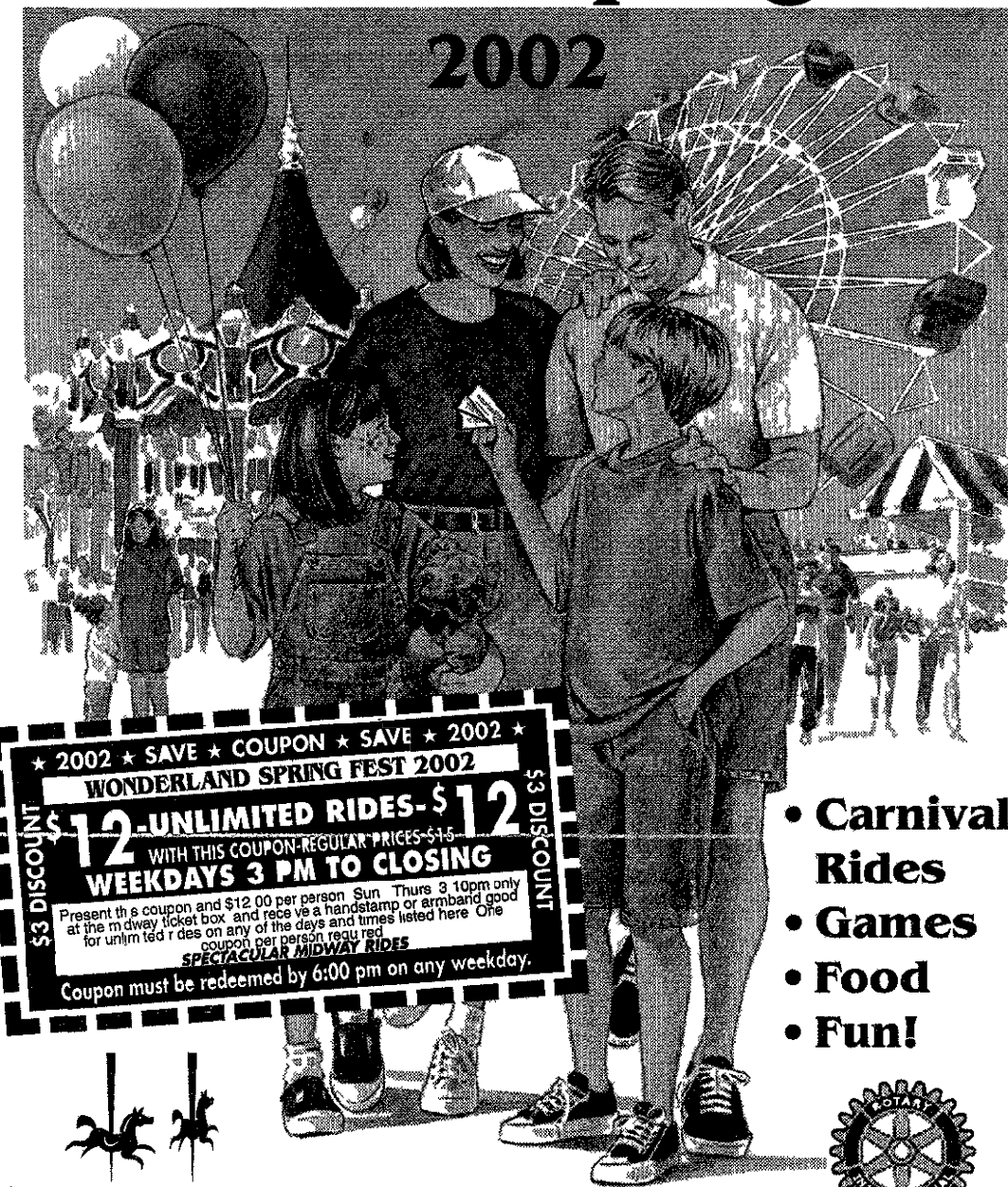

★ 2002 ★ SAVE ★ COUPON ★ SAVE ★ 2002 ★
WONDERLAND SPRING FEST 2002
\$12 UNLIMITED RIDES - \$12
WITH THIS COUPON - REGULAR PRICES \$15
WEEKDAYS 3 PM TO CLOSING
Present this coupon and \$12.00 per person Sun-Thurs 3:00pm only at the midway ticket box and receive a handstamp or armband good for unlimited rides on any of the days and times listed here. One coupon per person required. **SPECTACULAR MIDWAY RIDES**
Coupon must be redeemed by 6:00 pm on any weekday.

- Carnival Rides
- Games
- Food
- Fun!

Playworld Amusements

APRIL 24th - MAY 5th

Hours: 3-10pm Weekdays,
12-11pm Saturday, 12-10 Sunday

Wonderland Mall • Livonia
(S. W. Corner of Plymouth Road and Middlebelt)

Midway provided by Wonderland Mall and Livonia Rotary Club

Factory Authorized Sale
Take advantage of the Low Prices



We Have Southeast Michigan's Largest Selection of Quality Patio Furniture from traditional to beautiful contemporary styles and so much more!

Come in and be Surprised



- Patio Furniture & Accessories
 - Swimming Pools & Accessories
- Cornwell Pool & Patio carries the nation's most elegant brands and models of outdoor furniture like Winston, Homecrest, Woodard wrought iron, Lloyd-Flanders wicker and aluminum and more!

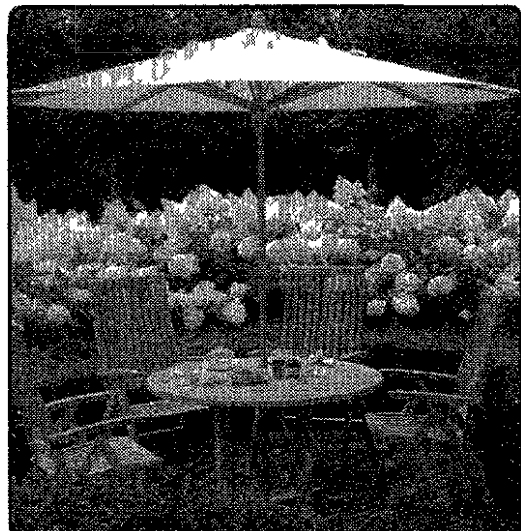

CORNWELL
pool & patio

ANN ARBOR
3500 Pontiac Trail
(734) 662-3117

PLYMOUTH
874 W. Ann Arbor Road
(734) 459-7410

Store Hours Mon Tues Thurs & Fri 10-6 Sat 10-4 Sun 12-4 Closed Wed
Extended Hours Beginning April 22nd

CARRIER OF THE MONTH: PLYMOUTH

D J Wagner, 12, is the Plymouth Observer's Carrier of the Month for April. The son of Matt and Debbie Wagner, he has three siblings, Paige, 11, also a carrier, Kristin, 7, and Ryan, 2.



D.J. Wagner

If you want to be a Plymouth Observer carrier, please call 591-0500.

A seventh grader, being home schooled, whose favorite subjects are history and science. His plans include being home-schooled through high school and becoming an environmental engineer. He enjoys aggressive skating, playing hockey and reading. He has been a member of the hockey team division champions and has won a summer camp leadership award. He enjoys meeting the people on his route and feels that being a Plymouth carrier has taught him responsibility.

Credit union partners with Smith

A recycling program pioneered by Smith Elementary School Principal Peggy Brooks recently got a big boost from local business.

Community Federal Credit Union recently donated a large supply of pencils, made of recycled products, to Smith Elementary in recognition of the school's recycling efforts.

In October 2001, Brooks launched a program to promote recycling at the school. In addition to paper and corrugate, Brooks recognized an opportunity to recycle the nearly 1,500 polystyrene lunch trays that are used each week.

When Brooks proposed the lunch tray recycling idea to the student body, third-grader Garrett Layman volunteered for the task.

"The program is a success because of Garrett," Brooks said. "Each lunch period he routinely collects the trays and prepares them for storage for the weekly pickup."

The city of Plymouth provides bins and a dumpster for the recycled prod-

ucts on the school grounds.

Natalie McLaughlin, Community Federal's Business Partnership Coordinator, explained the credit union's donation.

"We wanted to show our support for the school's efforts by giving them a supply of pencils that are made from a minimum of 60 percent of the polystyrene post consumer lunch trays and reclaimed sawdust," McLaughlin said. "We are thrilled to sponsor Garrett and Smith School by providing them with these pencils that bring awareness to the importance of recycling."

Brooks has developed a program for Garrett to distribute the recycled pencils as a reward to students, faculty and staff that he, in turn, sees doing a good deed.

McLaughlin said that Community Federal has a number of school partnerships in the communities where its members live or work.

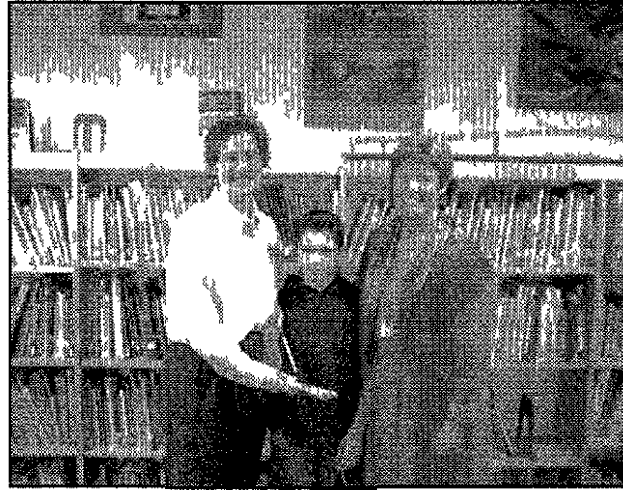

Recyclers: Smith Elementary School Principal Peggy Brooks stands with third-grader Garrett Layman and Natalie McLaughlin of Community Federal Credit Union, which donated recycled pencils to the school.

SENIOR HEALTH CARE? AT MY AGE?

It's not as strange as it sounds. In fact, it's smart. As you grow older, you have an increased risk for problems like arthritis, osteoporosis, heart disease and memory loss. That's why it's important to take steps now to treat and prevent them. And Senior Health Services at Saint Joseph Mercy Health System can help.

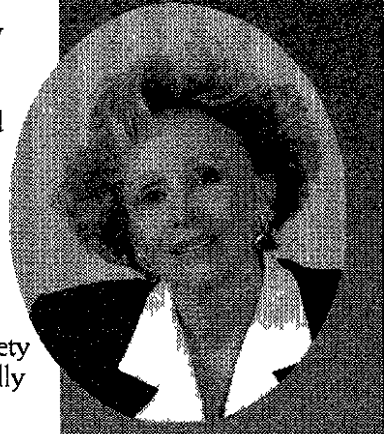

Here, you can meet with a variety of medical professionals specially trained in the health needs of maturing adults. These experts understand the aging process and problems which occur. They can monitor your health, identify risks and educate you on the newest ways to treat and prevent disease, helping you stay in tip-top shape both today and throughout the coming years. Be smart. Get an early start on a healthier you! Call for an appointment today.



SAINT JOSEPH MERCY SENIOR HEALTH SERVICES

Saint Joseph Mercy Canton Health Center
1600 S. Canton Center Rd.
Ste. 220 • Canton
734-398-7588

Layoffs from page A1

allowance "isn't keeping pace with inflation, or the Consumer Price Index, or any of the measures we use to look at our economy. Our district has costs that are rising much more rapidly."

"Last year we made significant reductions in spending, and modest reductions in the year

prior to that," added Boher. "It is clear to us that reductions every year forward are likely to be deeper and deeper until the State of Michigan adjusts the funding formula."

"One guideline we held golden as we worked on how to go about with reductions was no increase

in class size projections, and we believe we're accomplishing that."

George Mozurkewich of Plymouth Township told board members that without good teachers, the education system will suffer.

"Layoffs are very hard on people who are let go, but it also has an adverse impact on the morale of the people who stay," he said. "I hope the board looks at all possible sources and options."

Board members who voted in favor of the layoffs are hopeful

most, if not all, the educators will be called back to work.

"We're very disappointed that we have to do any type of layoffs," said Trustee Marcy Staley. "It's always the last thing any board wants to do. We're very hopeful we can call these teachers back."

Boher said the layoffs represent about 30-40 percent of the \$1 million in cuts that will be presented to the Board of Education at its May 14 meeting, and will be discussed at a workshop budget session May 21.

15% off Dinner
After 4 p.m. Mon.-Sat. and ALL DAY SUN.
No Limit • Dine-in Only • Excludes Drinks (with this ad)

PAGODA INN 44515 Ann Arbor Road at Sheldon • Plymouth
Carry-Out Menu (734) 455-1660 (734) 455-1661
Open Daily Mon-Thurs 11-10 Fri 11-11, Sat noon-11 Sun noon-10

Plymouth Observer
It's all about you!

HOW TO REACH US

Susan Rosiek, Publisher
(734) 953-2100
srosiek@oe
homecomm.net



Hugh Gallagher, Managing Editor
(734) 953-2149
hgallagher@oe
homecomm.net



Brad Kadrich, Editor
(734) 459-2700
bkadrich@oe
homecomm.net



C.J. Risak, Sports Editor
(734) 953-2108
cjriskak@oe
homecomm.net



Tony Bruscato, Reporter
(734) 459-2700
tbruscato@oe
homecomm.net



Bryan Mitchell, Photographer
(734) 459-2700
bmitchell@oe
homecomm.net



Greg Phillips, Delivery Manager
(734) 953-2244
custserv@oe
homecomm.net



Lisa Walker, Ad Representative
(734) 953-2168
lwalker@oe
homecomm.net



- Circulation 734-591-0500
- Classified Advertising 800-579-7355
- Display Advertising 734-591-2300
- Home Delivery 734-591-0500
- Newsroom FAX 734-591-7279
- Newsroom 734-953-2104
- Photo Reprints* 734-591-0500
- Sports Nightline 734-591-2104

* Photo orders must be for pictures that have been taken by our staff photographers. Please provide publication date, page number and description of the picture, which must have been published within the past six months. Prints are \$20 for the first print, \$7.50 for each additional print. Payment is in advance (check or credit card).

Visit us on the web at: www.observerandeccentric.com

SUBSCRIPTION RATES

CARRIER DELIVERY	MAIL DELIVERY
Six months \$25.50	One year \$62.60
One year \$51.00	One year (Sr Citizen) \$51.60
One year (Sr Citizen) \$41.60	One year (out of State) \$97.60
Newsstand 75¢ per copy	



A HomeTown Communications Network™ publication
794 South Main, Plymouth, MI 48170
(Between Ann Arbor Rd., and Ann Arbor Tr. across from March Tire)

SPRING ADDITIONS
to our award-winning menu

torched chicken quesadilla cajun-blackened chicken grilled in a tortilla with fire-roasted peppers, onions and fontina cheese \$6.95

chicken and artichoke pizza flame-grilled chicken with herb-infused olive oil, artichoke hearts, sundried tomatoes, roasted garlic and smoked mozzarella \$7.95

grilled flank steak over artichoke, mashed redskins with a roasted pepper sauce, onions, gorgonzola and mushrooms \$12.95

stacked eggplant fried crisp and layered with smoky wood-roasted tomato eggplant relish and shredded parmesan \$12.50



Bonfire Bistro & Brewery
39550 Seven Mile Road (at Haggerty)
Northville • 248-735-4570
www.michiganmenu.com

25% off your guest check

Present this coupon and receive 25% off your guest check (excluding alcohol & beverages). Choose from our entire menu. Not redeemable for cash. Expires May 24, 2002.

39550 Seven Mile Road (at Haggerty)
Northville • 248-735-4570 • www.michiganmenu.com

ATTENTION LAWN CUTTERS!

Durable Lifetime warranty on tractor frame and the leading edge of the deck.
Productive 23 or 25 hp Kawasaki engines, 52" 60 or 72" side-discharge decks, optional 9 bushel BAC-VAC™ catcher, 12.2-gallon fuel capacity, unmatched slope-handling performance.
Comfortable Automatic park brakes, foot-operated deck lift, comfy seats, most versatile cup holders in the industry.

Starting As Low As \$7,995

HUSTLER
Turf Equipment

Hustler® Z

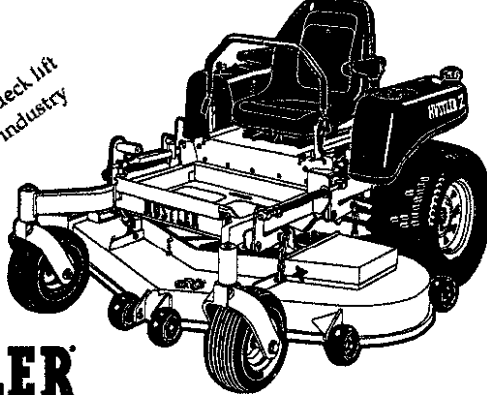

The Z with a difference!

W.F. MILLER CO.
The Professional's Choice On Turf
25145 Trans X Road • Novi

Take I 96 to the Novi Rd. exit go south 1 mile to Trans X Rd. Turn left follow down to the W.F. Miller Co.

Mon - Thurs 7:00 a.m. - 5:00 p.m.
Sat 8:00 a.m. - 12:00 p.m.
248-349-4100
www.wfmiller.com

FREE KARTCO FUN KART!
with purchase. Hurry! Offer Ends Soon.

FREE FAUX FINISH Clinic
AT SHERWIN-WILLIAMS!

Saturday, April 27th
10:00 am

Jason Garlow, from Beyond Painting, will demonstrate a variety of faux finish techniques.

20% OFF
Your next purchase at the Plymouth Sherwin-Williams store.

All savings are off regular price. Excludes Duramax® Exterior Coating, spray equipment, ladders and special order books. Present this coupon at time of purchase. Coupon has no cash value. Coupon Valid 4/27/02 and 4/28/02.

PLYMOUTH
561 Ann Arbor Rd.
734-453-7870

Call today to reserve a space for you and a friend.

Only At **SHERWIN-WILLIAMS PAINTS**

Ask How. Ask Now. Ask Sherwin-Williams.™
Visit us at www.sherwinwilliams.com

Not responsible for typographical or artwork errors. © 2002 The Sherwin-Williams Company

OBITUARIES

THELBERT SMITH
Services for Thelbert Smith, 97, of Plymouth, were held April 20 at the Schrader-Howell Funeral Home with the Rev Michael Bryan officiating. Burial was at Riverside Cemetery in Plymouth.

Mr Smith was born Dec 23, 1904 in Obion County, Tenn and died April 17 in Ann Arbor. He was a factory worker at Associated Spring and Axle Company for 15 years (Barnes, Gibson, Raymond Group) in Plymouth Township. He also worked at the bomber plant in Ypsilanti.

He came to the Plymouth community in 1943 from Obion County, Tenn. He was a member of the First Baptist Church of Plymouth since 1953. He was a member of the UAW. He loved to garden and work on cars.

Survivors include sons, James (Lou Ann) Smith of Livonia and Jerry (Patricia) Smith of Plymouth, 10 grandchildren, nine great-grandchildren, and a brother, William Dolly of Obion County, Tenn.

Memorial contributions may be made to the American Diabetes Association.

Arrangements made by Schrader-Howell Funeral Home.

LINDA JOY ROWLAND

Services for Linda Rowland, 54, of Plymouth Township were held April 23 at the chapel of L J Griffin Funeral Home.

Mrs Rowland was born Jan 3, 1948 in Canada and died April 20 in Plymouth Township. She worked as an administrative coordinator for Johnson Controls.

Mrs Rowland was preceded in death by her father, Al Lynas.

Survivors include husband, Christopher C., daughter, Erin (Cameron) McLean, son, Ian (Melissa), mother, Joy Lynas, and grandson, Matthew.

Arrangements made by L J Griffin Funeral Home, Canton Chapel.

JEROME J. STASZEL

Services for Jerome Staszel, 61, of Plymouth, were held April 20 at Our Lady of Good Counsel Catholic Church with the Rev Doc Ortman officiating.

Mr Staszel was born Nov 7, 1940 in Detroit and died April 17 in Livonia. He worked for Edfr Industries in Livonia as a tool and die maker for 11 years. He came to the Plymouth community in 1966 from Detroit. He was in the Marine Reserves. He was an avid baseball fan and player.

Survivors include wife, Barbara of Plymouth, son, Jerome (Amy) Staszel, Jr. of Brighton, daughters, Shelly (John) Watkins of Shelby Township and Jennifer (Andrew) Manriquez of Colorado, four grandchildren, two sisters, and two brothers.

Memorial contributions may be made to the family. A memorial fund to be established at a later date.

Arrangements made by Schrader-Howell Funeral Home.

JANET MARIE SANTILLI

Services for Janet Santilli, 60, of Plymouth were held April 15

at St Thomas a'Becket Catholic Church with the Rev C Richard Kelly officiating.

Mrs Santilli was born July 22, 1941 in Livonia and died April 14 in Plymouth. She was a homemaker.

Survivors include husband, Samuel G. Santilli of Plymouth, son, Greg S. (Sally) Santilli of Canton, son, Kevin (Samantha) Santilli of Franklin, Ind., son, Matt (Dawn) Santilli of Leo, Ind., daughter, Tracey (Mark) Toth of Livonia, daughter, Nicole (Brian) Santilli of Plymouth, son, Al Santilli, brothers, Joe, Ron and Harvey Jaksch, and nine grandchildren.

Memorial contributions may

be made to Angela Hospice, 14100 Newburg, Livonia, MI 48154-5010.

Arrangements made by Vermeulen Funeral Home.

BETTY JANE PRANGE

Services for Betty Prange, 85, of Salem Township, were held April 12 at the Vermeulen Funeral Home with the Rev Richard Pingilley officiating. Burial was at Glen Eden Memorial Park in Livonia.

Mrs Prange was born Oct 1, 1916 in Detroit and died April 8 in Ann Arbor. Mrs Prange was a payroll keypunch operator for Ford Motor Company and also a homemaker.

She was preceded in death by her husband, Robert Prange. Survivors include son, Fred (Betty) Burchard of Royal Oak, daughter, Sally Ann (David) Armstrong of Plymouth, daughter, Sharon Diane (William) Rose of Woodbridge, Va., son, Robert D. Prange, Jr. of Washington, DC, brother, Jack Mitchell, sister, Martha Day of Lockport N Y, grandchildren, Deborah, Katherine, Joann, Gordon, Margaret and Lorrie, and 21 great-grandchildren.

Memorial contributions may be made to Coral Ridge Ministries or Concerned Women of America.

Arrangements made by Ver-

meulen Funeral Home.

GLADYS R. KELLEY

Services for Gladys Kelley, 77, of Plymouth were held April 24 at Hosanna Tabor Lutheran Church with the Rev Lawrence E Witto officiating. Burial was at Glen Eden Memorial Park in Livonia.

Mrs Kelley was born Oct 28, 1924 in Detroit and died April 21 in Plymouth. She worked in the accounts payable field. She was a member of Hosanna Tabor Lutheran Church.

She was preceded in death by her husband, Kenneth Kelley.

Survivors include son, Robert (Carol) Kelley of Canton, son,

Wayne R. (Gail) Kelley of Canton, son, Brian (Jennifer) Kelley of Westland, daughter, Deborah (Bob) Lamm of Fort Wayne, Ind., brother, Raymond (Eunice) Haase of St. Clair Shores, grandchildren, Steven, Kevin, Dustin, Kristin, Lea and Marc, and great-grandchildren Alysha and Alex.

Memorial contributions may be made to Hosanna Tabor Lutheran Church, 9600 Leverage, Redford, MI 48239, or the American Cancer Society, 18505 W 12 Mile, Southfield, MI 48076.

Arrangements made by Vermeulen Funeral Home.

STARTS WEDNESDAY, APRIL 24

power shopping sale

25-50% OFF - SAVINGS STOREWIDE



LADIES, PETITES, PARISIAN WOMAN, JUNIORS

SALE 79.99-99.99 Great selection of spring and summer dresses and pantsuits. Reg 88.00-172.00. IN DRESSES.

30-50% OFF Entire stock of spring and summer suits from Travis Ayers. Larry Levine and more. Reg 200.00-350.00. **sale 100.00-245.00.** IN DRESSES.

30% OFF Parisian Signature shantung separates. Reg 54.00-60.00. **sale 37.80-42.00.** IN LADIES SPORTSWEAR.

30% OFF Large selection of casual collections from your favorite American female designer. Reg 24.00-98.00. **sale 16.80-68.60.** IN LADIES SPORTSWEAR.

SALE 17.99 Choose from a variety of sleeveless knit tops and sweaters from relativity. Reg 24.00-34.00. IN LADIES SPORTSWEAR.

SALE 39.99 Solid and novelty cropped pants from Logic and Parisian Signature. Reg 58.00. IN LADIES SPORTSWEAR.

30% OFF Famous-maker separates for petites and Parisian Woman. Reg 38.00-148.00. **sale 26.60-103.60.** IN PETITES AND PARISIAN WOMAN. SELECTION VARIES BY STORE.



INTIMATE APPAREL

40% OFF Best selling bras from Vanity Fair, Bali and Olga. Reg 24.00-29.50. **sale 14.40-17.40.** IN INTIMATE APPAREL.

TAKE AN EXTRA **15% OFF** any single sale or clearance item valid Wednesday April 24 only. *or take 10% off any single sale or clearance item in shoes, men's suits and sport coats and small electronics. Excludes cosmetics, fragrances, special events, great buys and watches in the jewelry, maternity, intimate apparel, Preswick & Moore dress shirts, Levi's, select dresses and suits, special orders, everyday low price items, day spa and salon services, fur services, electronic gift cards and gift certificates. Coupons cannot be combined. Must present coupon for savings. Not valid on previously purchased items.

SALE 24.99 Shorty pajamas, robes and more from Planet Sleep, Parisian Intimates and more. Reg 34.00-48.00. IN INTIMATE APPAREL.

SALE 19.99 Sleepshirts from Parisian Intimates and Carole Hochman. Reg 28.00-36.00. IN INTIMATE APPAREL.

ACCESSORIES, FASHION JEWELRY, SHOES

30% OFF Great selection of sunglasses. Reg 22.00-45.00. **sale 15.40-31.50.** IN ACCESSORIES.

25-50% OFF Large selection of anklet and toe ring sets. Reg 8.00-30.00. **sale 5.60-14.99.** IN ACCESSORIES.

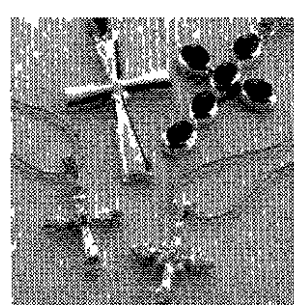

50% OFF Entire stock of sterling silver and a large selection of fashion jewelry. Reg 15.00-300.00. **sale 7.50-150.00.** IN JEWELRY.

SALE 39.99 Great selection of shoes and sandals from Steve Madden, Nine West, White Mountain, Van Eli, Etienne Agner, relativity, Enzo Angiolini and more. Reg 49.00-69.00. IN WOMEN'S SHOES.

50% OFF Large selection of shoes and sandals from Enzo Angiolini, Nine West, White Mountain, Two Lips, Naturalizer, Unisa, Etienne Agner and relativity. Reg 49.00-75.00. **sale 25.00-37.50.** IN WOMEN'S SHOES.

SALE 49.99 Comfort sandals and shoes from Clarks, Merrell and Born. Reg 65.00-75.00. IN SHOES.

25% OFF Many beach and casual shoes from Rocket Dog, Candie's and Rampage. Reg 22.00-35.00. **sale 16.50-26.25.** IN WOMEN'S SHOES.

30% OFF Great selection of children's sandals and shoes from Stride Rite, Esprit, Candie's, Skechers and Sam & Libby. Reg 28.00-52.00. **sale 19.60-36.40.** IN CHILDREN'S SHOES.

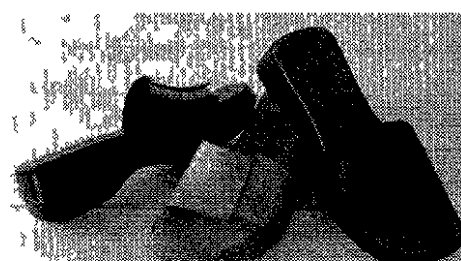

SALE 49.99 Save on a large selection of women's shoes and sandals from Unisa, Enzo Angiolini, AK Anne Klein, Franco Sarto, Nine West, Timberland, Naturalizer and more. Reg 59.00-79.00. IN WOMEN'S SHOES.

TAKE AN EXTRA **15% OFF** any single sale or clearance item valid Thursday April 25 only. *or take 10% off any single sale or clearance item in shoes, men's suits and sport coats and small electronics. Excludes cosmetics, fragrances, special events, great buys and watches in the jewelry, maternity, intimate apparel, Preswick & Moore dress shirts, Levi's, select dresses and suits, special orders, everyday low price items, day spa and salon services, fur services, electronic gift cards and gift certificates. Coupons cannot be combined. Must present coupon for savings. Not valid on previously purchased items.

MEN

SALE 14.99 Preswick & Moore cotton polo, crew-neck and v-neck shirts. Reg 25.00. IN MEN'S.

SALE 24.99 Solid pique polo or micro-sanded twill shorts from Izod. Reg 34.00-38.00. IN MEN'S.

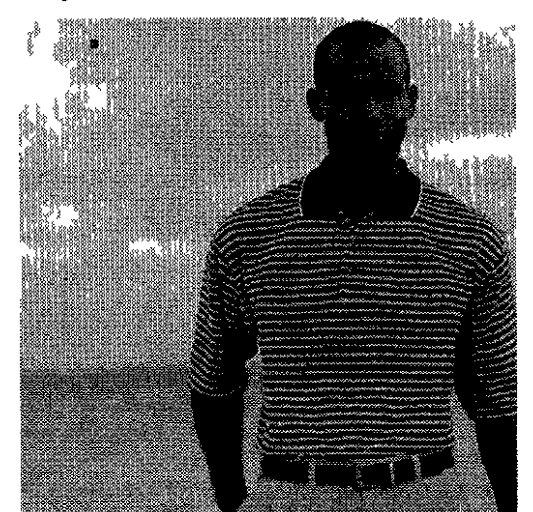

SALE 19.99 An assortment of shorts and knit and woven shirts from Preswick & Moore and Savane. Reg 34.00. IN MEN'S.

SALE 14.99 Young men's cargo shorts from Manno Bay and Retimé. Reg 30.00. IN MEN'S.

30% OFF Entire selection of spring fashion sport coats. Reg 275.00-450.00. **sale 192.50-315.00.** IN MEN'S.

SALE 24.99 Fashion dress shirts from Preswick & Moore and Hathaway. Reg 37.50-50.00. IN MEN'S.

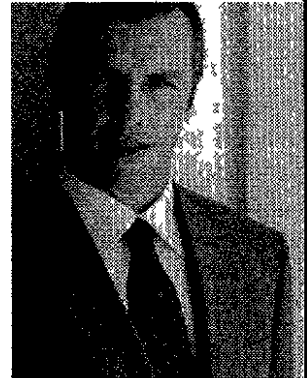

GIFTS

SALE 9.99 Block crystal Olympic 9" bowl or 10" vase. Reg 40.00. IN GIFTS. QUANTITIES LIMITED.

SALE 14.99-35.99 Gorham "Chantilly" crystal collection. Reg 29.00-72.00. IN GIFTS. QUANTITIES LIMITED.

CHILDREN

SALE 14.99 Shorts, capris and flood pants for girls from Zana-Di, Squeeze and Mudd. Reg 24.00-30.00. IN CHILDREN'S.

30% OFF Selected swimwear from Beach Native, Coral Cove and Izod. Reg 22.00-26.00. **sale 15.40-18.20.** IN CHILDREN'S.

SALE 12.99 Selected knit, rayon and woven tops and twill shorts for boys in sizes 4-20. Reg 20.00-30.00. IN CHILDREN'S.

THINKING ABOUT CENTRAL AIR CONDITIONING? **LENNOX** FREE ESTIMATES (734) 525-1930 Our 28th Year! UNITED TEMPERATURE

BEST TIME TO BUY! SAVE UP TO 25% 100's OF MODELS PRICED FROM \$899 ORDER NOW FOR PRIORITY INSTALLATION The Doll Hospital 3047 W 12 Mile Rd Berley (248) 943-3115 & Toy Sellen Shops Sat 10-8:30 Fri 10-6:30

WANTED ALL OLD TOY TRAINS, SLOT CARS and OLD TOYS Call...Merri-Seven Trains, Hobbies & Collectibles 248-477-0550 Tuesday-Saturday

15% OFF your first day's purchases when you open a Parisian credit account and use it. Subject to credit approval. See an associate for details. **PARISIAN** YOU'RE SOMEBODY SPECIAL Sorry, we can't make price adjustments to previously purchased merchandise. CALL 1-800-424-8185 TO ORDER ANYTIME. STORE HOURS: Laurel Park Place open Sun 12-6, Mon-Sat 10-9. FOR INFORMATION call 953-7500. CHARGE IT: Parisian Credit Card, MasterCard, Visa, the American Express® Card or Discover®. LOCATED AT LAUREL PARK PLACE IN LIVONIA, ON THE CORNER OF NEWBURGH ROAD AND SIX MILE ROAD (TAKE THE SIX MILE ROAD EXIT OFF INTERSTATE 275).

Read The Observer for local news

Colthurst
for
Judge



EXPERIENCE COUNTS

www.colthurstforjudge.com

Printed by Eagle Co. Inc. for Judge Comm. use
1810 Main St. Canton, MI 48107

Saunders from page A1

election.”
Saunders said the district's current financial problems present a challenge, but it's one she believes the district can, and has, learned to deal with.

“Do we have the money to give our students an excellent education? If you look at the MEAP scores, and the number of Merit Scholars, and the number of students going to college, obviously we're doing it,” she said. “We just need to tighten our belts.”

Saunders also said she'd like to confront diversity issues in the district.

“If you want to talk about a diverse population, we had it at Starkweather,” said Saunders. “But, we worked on respect and responsibility, no matter what color your hair was, what color your skin was, or your political viewpoints. We do have programs helping students to learn respect and responsibility, but I think we can do more.”

The renewal project at the high school complex is designed to keep freshmen and sophomores in their home schools, while developing smaller schools within schools. Will it work?

“I think they still have some

logistics to work out in having smaller education communities grouped in their own schools,” said Saunders. “I'm concerned that if we have a student assigned to Plymouth High School that they're going to be able to take advantage of classes in other buildings.”

Saunders has heard the complaints concerning the lack of communication to parents from the school board and administration.

“If some people are perceiving there isn't an openness, then there's a problem,” she said. “If people perceive they can't get the information they want, let's make it a little more open, a little more approachable.”

In the end, Saunders believes her biggest contribution to the school board may be her outlook on education.

“I'm the only professional educator in this election, which is a different point of view,” she said. “I've been around here and in other districts, and I've seen some things that work and some that don't which gives me somewhat of a different perspective.”

Blessed bikes



Safe riding: Father Joe Mallia, pastor of St. Kenneth Catholic Church, blessed the motorcycles and their riders last Saturday. The Blessings of the Bikes, a first-time event for St. Kenneth, attracted over 50 bikers. Observer reporter Renee Skoglund was there for a free ride. Read her column in HomeTown Life.

CANTON 6

Ford Rd 1 Mile W of I 275 (734)

\$4.99 Film by Tw Light 4-8pm daily

\$5.00 Kids all shows

\$5.50 DAILY Matinees til 4pm & Seniors

\$5.75 Students & Late Show Fri & Sat

\$7.50 Evenings Mon Thurs ALL SCREENS

0 No Passes DIGITAL STEREO

Unlimited Free Drink & 25c Corn Refills

Deluxe Air Hockey Table

MOVIE GUIDE

EVERYONE FREE

SPRING MATINEES!

SATURDAY & SUNDAY 10:00-11:00 AM

APRIL 20 & 21

RUGRATS IN PARIS (G)

APRIL 27 & 28

HARRIET THE SPY (PG)

THE SCORPION KING

THE ROCK

SHOWTIMES 4/21 - 4/25

THE SCORPION KING (PG 13)

12:15 2:30 4:45 7:00 9:15

SWEETEST THING (R)

1:15 3:15 5:15 7:30 9:30

HIGH CRIMES (PG 13)

11:50 2:10 4:35 7:10 9:35

PANIC ROOM (R) 12:00 2:20 4:50 7:20 9:45

THE ROOKIE (G)

(SUN 10:45) 1:25 4:10 6:50 9:20

ICE AGE (PG)

(SUN 11:00) 1:00 3:00 5:00 7:05 9:00

COUPON FREE 20oz DRINK

with \$1.50 (1/2 price) purchase of 48oz bag of buttery popcorn

www.canton6.com

Slumber Parties
by Angela

Providing the finest provocative products to enhance your intimate relationships in a party atmosphere in your own home.

Call to book your party or become a distributor!

734-560-7377

Parties for adult women only Must be over 18
1-800-717-6599 ext 1071

CHARTER TOWNSHIP OF CANTON REQUEST FOR BID

NOTICE IS HEREBY GIVEN that the Charter Township of Canton 1150 Canton Center S Canton Michigan will accept sealed bids at the Office of the Clerk up to 3:00 p.m. Thursday May 9TH 2002 for the following:
ONE (1) 312B CATERPILLAR HYDRAULIC EXCAVATOR OR EQUAL
Bid forms may be picked up at the Finance and Budget Department counter or you may contact Mike Sheppard at (734) 394 5225. All bids must be submitted in a sealed envelope clearly marked with the proposal name, company name, address and telephone number and date and time of bid opening. The Township reserves the right to accept or reject any or all proposals. The Township does not discriminate on the basis of race, color, national origin, sex, religion, age or disability in employment or the provision of services.

TERRY G BENNETT Clerk

Publish April 25 2002

22nd ANNIVERSARY SALE!

HELD OVER THRU SATURDAY APRIL 27TH!

22% OFF EVERYTHING IN THE STORE!

CHOOSE FROM OUR ENTIRE STOCK of MEN'S AND WOMEN'S SPRING FASHIONS

for him: tommy bahama nautica axis levi's cotton reel columbia peerless enro haggard arrow sans a belt raffi cotton traders
for her: sigrid olsen susan bristol tommy bahama david brooks graff blast carol anderson northern isles sarah arizona columbia
and many more for men and women



NEWBURGH PLAZA 37205 W. SIX MILE at NEWBURGH 734.591.9244
HOURS: MONDAY THRU FRIDAY 10-8 SATURDAY 10-6

Not valid with other discounts, promotions, sales, special orders, previous purchases, or gift certificate purchases. Sorry, no layaways.

NOW ACCEPTING APPLICATIONS FOR SUMMER EMPLOYMENT FULL AND PART TIME SALES POSITIONS NOW AVAILABLE

The Home Office Solution

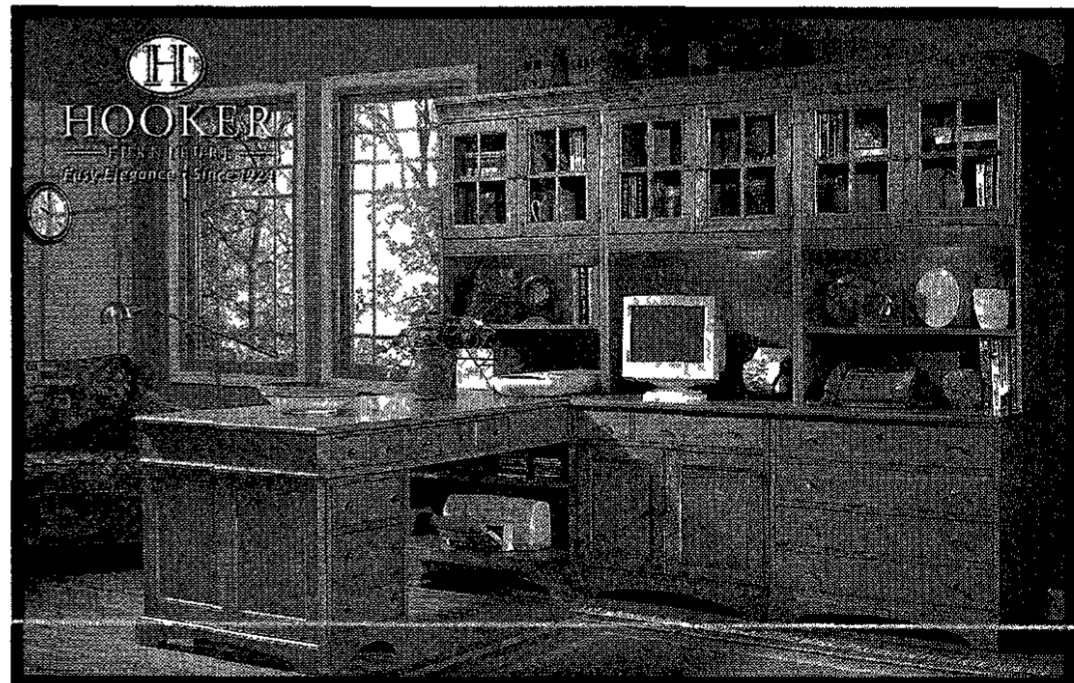

See us for quality Home/Office arrangements crafted by Hooker Furniture, that fits your budget, organizing needs and environment. Stop in today and you'll find savings up to 40% off retail!

Financing up to 12 Months with No Interest!*



Walker/Buzenberg
fine furniture

240 North Main Street • PLYMOUTH • (734) 459-1300
Mon, Thurs, Fri 10-9 • Tues, Wed, Sat 10-6 • Sun 1-5
With credit approval; see store for details • Sale ends 5-5-02

PLYMOUTH DISTRICT LIBRARY'S

POPULAR PICKS



Every week the Plymouth District Library staff provides the Observer with their list of "Best Sellers" based on the number of requests for titles by library patrons. The books are available by placing a request with the library, 453-0750.

NONFICTION

- 1) *Stupid White Men*, Michael Moore
- 2) *A Mind at a Time*, Mel Levine
- 3) *Driver #8*, Dale Earnhardt, Jr.
- 3) *BIAS*, Bernard Goldberg
- 4) *Sacred Contracts*, Caroline Myss

PARENT'S CHOICE

CHILDREN'S NEW PICTURE BOOKS

- 1) *Gaspard and Lisa at the Museum*, Anne Gutman
- 2) *Nursery Crimes*, Arthur Geisert
- 3) *I Want to Say I Love You*, Caralyn Buehner
- 4) *The Class Artist*, G. Brian Karas
- 5) *Bridget and the Gray Wolves*, Pija Lindenbaum

FICTION

- 1) *Everything's Eventual*, Stephen King
- 2) *2nd Chance*, James Patterson with Andrew Gross
- 3) *Atonement*, Ian McEwan
- 4) *The Nanny Diaries*, Emma McLaughlin and Nicola Kraus
- 5) *Body of Lies*, Iris Johansen
- 6) *The Pursuit*, Johanna

Expo features food, businesses

The Plymouth Community Chamber of Commerce, with major sponsorship from Hines Park Lincoln Mercury, presents Showcase Plymouth 2002, the annual mini-business expo, and Taste of Plymouth, featuring 15 of Plymouth's best eateries and pizzerias.

Showcase Plymouth takes place from 5-7 p.m. May 1 at St. John's Golf and Conference Center, 5 Mile and Sheldon. The event features more than 60 booths, and will see scholarships and the service club's Volunteer of the Year award handed out.

Admission is \$4. For more information, call the chamber at (734) 453-1540, or visit the Web site, www.plymouthchamber.org

Nelson from page A1

to this very hard (financial) problem."

As a business owner, Nelson said he works continually at communicating ideas to his clients. And, to that extent, he believes there needs to be more communication between the school district and its customers.

"The electronic communication is a joke," said Nelson, referring to the district's Web site. "I can't go to it and drop e-mails to teachers or look for assignments I'd like to have the schools' finances available."

"We should investigate making the Web site an educational opportunity, like putting together the yearbooks at the high school."

Nelson does give credit to the schools for recently televising regular school board meetings for those who can't make the sessions.

Nelson, whose daughter participated in the Talented and Gifted (TAG) program, said he's done considerable research into administration thoughts of changing the magnet school program to one based at each elementary school.

"The research I see indicates that while we may be serving more kids (with programs at each grade school), it may be a less effective program. That may not be the direction we want to go."

Nelson looks forward to the changes at the high school complex which will emphasize putting smaller groups of students together instead of the large, campus-like atmosphere.

"For highly motivated kids, the high school complex is a great opportunity," said Nelson. "But, for others, it's a great opportunity to get lost among

5,000 people on campus. The idea of smaller schools, groups of 800 and later fewer, is a really good idea. We might find that we have less kids falling through the cracks."

The 18-year Canton resident is also concerned about the future of the district's facilities, calling it a major challenge.

"We're a growing district with aging buildings. That's a tough combination, and a key challenge," he said.

And with the challenge, according to Nelson, comes a balancing act to determine which buildings in the district best fit the needs of the community.

"The biggest question is does each facility best serve the needs of our kids?"

Congresswoman Lynn Rivers Invites You to Coffee Hour at these Locations:

<p>Saturday, April 27 ANN ARBOR Cafe' Mane 11:00 am - 12:30 pm 1759 Plymouth Rd</p>	<p>Monday, April 29 NEW BOSTON Rivers Edge Cafe' 8:30 am - 10:00 am 37005 Huron River Dr</p>	<p>Friday, May 3 NORTHVILLE Edwards Cafe' 8:30 am - 10:00 am 116 E Dunlap St</p>
<p>Monday, May 6 SUMPTER Jus' Bad Food 8:30 am - 10:00 am 25525 Sumpter Rd</p>		<p>Saturday, May 11 INKSTER Booker T Dozier Recreation Ctr 11:00 am - 12:30 pm 2025 Middlebelt Rd</p>
<p>Saturday, May 18 WESTLAND American Family Diner 8:30 am - 10:00 am 501 S Wayne Rd</p>	<p>Thursday, May 30 AUGUSTA TWP Pickle Barrel 2:30 pm - 4:00 pm 10256 Willis Rd</p>	<p>Thursday, May 30 NEW BOSTON Waltz Inn 7:00 pm - 8:30 pm 28104 Mineral Springs</p>

For further information please call: 734-485-3741

it's all inside.



stores catalog

JEWELRY SALE

Save 60-75%*

3 DAYS ONLY! HURRY IN. QUANTITIES LIMITED!

*Savings apply to merchandise shown.

 <p>Sale \$199 Reg. \$507 2 CTTW diamond bracelet. 10K gold.</p>	 <p>Sale \$149 Reg. \$507 1/2 CTTW diamond ring. 10K gold.</p>
 <p>Your Choice 59.99 Reg. 167.99 1/4 CTTW diamond earrings. 14K gold.</p>	 <p>Your Choice 39.99 Reg. \$186 1/4 CTTW diamond pendant. 10K gold.</p>
 <p>Sale 79.99 Reg. \$298 Triple strand 5-5.5 mm cultured freshwater pearl necklace. 14K gold.</p>	 <p>Sale 59.99 Reg. 167.99 Multi-precious gemstone heart pendant. Ruby/sapphire/emerald/diamond. 10K gold.</p>
 <p>Sale 69.99 Reg. 249.99 Gold rope necklace/bracelet set. 10K gold.</p>	 <p>Sale 39.99 Reg. 149.99 Gold bangle/earring set. 10K gold.</p>
 <p>Sale \$249 Reg. \$667 1 CTTW diamond chevron necklace. 10K gold.</p>	 <p>Your Choice \$99 Reg. \$337 1/4 CTTW earring, pendant or ring. 14K gold.</p>

Take an extra **15% off** fine jewelry & watch clearance. Already 40-60% off original prices!

30% off Citizen® watches

30% off Timex® watches

25% off Fine & fashion watches

60% off Basic gold chains. Plus, take an extra 10% off sale prices!

50-60% off Gold jewelry

30-50% off Gemstones & cultured pearls

20-40% off Diamond jewelry

JEWELRY SALE PRICES EFFECTIVE THROUGH 4/27/02. Regular prices reflect offering prices which may not have resulted in actual sales. Any event designated as a sale always excludes Special Buys, Trunk Shows, items sold every day in multiple lots of two or more and Value Right items which are sold at our best price every day. Bonus Buys and Bright Buys are excluded from any additional percentages off or dollar off coupons. Jewelry photos may be enlarged to show detail. Diamond carat weights (CT) represent the approximate total weight (TW) of all diamonds in each setting unless noted. Diamond solitaire weights may vary between .01 and .05 carat. Diamond total weights may vary between .01 and .08 carat. Diamond sale includes only that jewelry where diamonds constitute the greatest value. Diamond accents may not constitute greater value than gold. Gemstones may have been treated and may require special care. 10K and 14K gold in our assortments. Available only at JCPenney stores with Fine Jewelry departments. Merchandise shown is representative of our assortment. Selection may vary by store. Some merchandise may not be available at every store.

ONE WEEKEND - TWO SHOWS

COMPUTER SHOW

APRIL 26-27-28
FRI 12-9 • SAT 10-9 • SUN 10-6

SAVE UP TO 70%
ON SOFTWARE, HARDWARE AND ACCESSORIES
COMPUTERS, GAMES, SCANNERS, C D'S, MONITORS, BOOKS & MUCH MORE!

OVER 180 TABLES

NEW & USED PRODUCTS!
BUY! TRADE! SELL!
ADMISSION IS ONLY \$2.00 PER CARLOAD!
FRIDAY IS SET-UP DAY
Not all Dealers Participate

ANTIQUESHOW

APRIL 26-27-28
FRI 12-9 • SAT 10-9 • SUN 10-6

ANTIQUES, SELECT COLLECTIBLES, VINTAGE AND NOSTALGIA ITEMS



Old & Rare Books, Victorian Period Furniture, Pattern Glass, Reference Books, Porcelain, Toys, Movie Items, China, Pottery, Primitives, Silver & Much More!



SPRING CARNIVAL

NOW THROUGH APRIL 28TH

FUN FOR THE ENTIRE FAMILY • RIDES • GAMES • FOOD

HOURS: MON - FRI 4PM TO MIDNIGHT • SAT & SUN NOON TO MIDNIGHT

Gibraltar

TRADE CENTER, INC.

1-75 & EUREKA RD (EXIT 36) TAYLOR
734-287-2000
WWW.GIBALTARTRADE.COM

FREE FRIDAY ADMISSION
WITH THIS COUPON
FRIDAY APRIL 26TH ONLY

Plymouth Observer

Part of HomeTown Communications Network™

Brad Kadrich
COMMUNITY EDITOR
Hugh Gallagher
MANAGING EDITOR
Susan Rosiek
PUBLISHER
Dick Brady
VP/General Manager

Jeanne Towar
VP EDITORIAL
Dick Aginlan
PRESIDENT
Phillip Power
CHAIRMAN OF THE BOARD

Our fundamental purposes are to enhance the lives of our readers, nurture the hometowns we serve and contribute to the business success of our customers

District must explore options before layoffs

The news wasn't quite as gloomy at Tuesday's school board meeting as was previously reported

School Superintendent Kathleen Booher reported Tuesday night that the district is notifying 18 — not 19, as originally thought — teachers that they may not have jobs when the next school year starts

Unless you're that 19th teacher, though, the news certainly isn't welcome. And it raises some troubling issues, and questions

But not all the news is doom-and-gloom, there's even a possibility no teachers will be laid off. It sounds like Midas himself will have to make his way through the district's budget to turn some things into gold, but Booher pointed out some things that could happen to make the future a little brighter for those about to get pink-slipped

And, lest we be purveyors of doom, let us point out that the announcement of the possible layoffs was required by a contractual language that obligated the district to inform teachers 60 days before the current contract expires. As Booher is quick to point out, the announcement of the possible layoffs is not the same as actively laying teachers off

But the district has been saying for months now that dark financial clouds loom, that's not a surprise. While there is currently a fund surplus, district officials are hesitant to tap it. Proposal A doesn't do Plymouth-Canton many favors, district officials have been lobbying Lansing forever about making changes to allow the district to raise more money from its residents

At the same time, though, it should be pointed out the district approved spend-

ing more than \$300,000 on a new science program. That's all well and good, we believe the district should strive to provide the best curriculum possible within its budget constraints

But there have to be teachers available to teach it, or it's like buying a \$300,000 treadmill for the district to hang its laundry on

The larger picture is this: What better evidence of the flaws in the state's education funding formula than the fact that a quickly growing district — Plymouth-Canton expects somewhere in the neighborhood of 100 new students or more next year — being forced to lay off its most important asset?

Before P-C officials cry too deeply into their beer, though, perhaps they should look at the bright side. They're better off than Redford Udon, which is losing students, and Livonia, which is talking about closing buildings. Neither of those is the case in Plymouth-Canton

Laying off teachers, especially in a district that has worked as hard as Plymouth-Canton at lowering class sizes, should be a drastic, last-resort step. Teachers are the face of the district for students and their parents, and the district's most valuable asset

We understand that a huge chunk of the district's \$125 million budget is eaten up in personnel costs. And we believe the administration has worked hard at keeping costs in all areas down. We hope — and believe — Booher, financial director Patricia Brand and the rest of the administration are searching for every way possible to avoid teacher layoffs

This is a district that believes kids come first. Not laying off teachers would be a great way to show it

Proms and drinking are a combination to avoid

Prom time again, time to send out a warning

But it's a pretty good bet that the people who need to hear this most will not be reading an editorial in The Observer

It's also a good bet that even if they did read it, they wouldn't be deterred from doing what they're going to do

Still, every year we make the same appeal in the hopes of reaching someone. It's selfish, really, because we'd rather not be covering yet another story of a prom night gone terribly wrong because of drugs and alcohol. Anyone who has been in community journalism for any amount of time is all too familiar with young lives ended too soon or ruined by a careless and stupid decision to give over self control to mind altering substances

It's not as if the message isn't proclaimed loud and clear

Since early in their school years kids have been exposed to DARE and other sincere anti-drug programs. Schools have exhibits with mangled cars and pictures of mangled bodies. Groups like MADD and SADD distribute literature repeating the effects of just one beer, one glass of wine, one shot of liquor. Young girls are warned that the possibility of unwanted sexual attention increases dramatically when alcohol is involved

But too many young people turn a deaf ear because "We want to PARTY, DUDE!" "Adults had their fun and they just want to deny us ours" "I can handle it, everything's under control" "A few beers can't hurt anybody" "Whaddya want us to be, a bunch of nerds" "Girls just wanna have fun" "Boys will be

boys"

We could counter with "Dead is dead" Paralyzed, raped and criminally liable are other ideas we could suggest to the young and hope they understand

Parents look forward to proms. They love seeing their daughters in pretty gowns, their hair swept up, giddy with anticipation. They love seeing their sons awkward in tuxedos and ruffles, cracking jokes to hide their anxiety. Parents take pictures. They give warnings. Then they send their young adults off with a fervent prayer that everything will be fine

The sad thing is there is no telling who will make that fatal mistake. Sometimes it is the child of inattentive parents who set a bad example and encourage reckless behavior. But often it is the straight-arrow children of loving but strict parents, who once out of sight decide to take another direction

As futile as it sometimes seems to be, we do urge parents to sit down with their children and tell them once again that drugs and alcohol are dangerous. Driving under the influence will endanger them, their passengers and others. Drinking and drugs can lead to dangerous and unhealthy sexual situations. Drinking and drugs can lead to potentially violent encounters

Tell them and tell them again. Keep the conversation going. Be informed. Teach, don't preach. Be a good example. Show them that a happy life and a good time don't need to be fueled by alcohol and drugs

GUEST OPINION

Posthumus plan is right for taxpayers

I find it interesting to see that the only people against Lt Gov Posthumus' 3/5's plan are his opponents and the liberally biased media

Perhaps they lash out because they know that Dick Posthumus has a plan that is right for Michigan taxpayers

Maybe the reason they strongly oppose his plan is that they've lost sight of what the voters want for themselves and their families

What the voters want is comfort in these unstable economic times. They

want to know that the money they earn will stay with them and their families, not in the hands of Lansing lawmakers. They want to know that when lawmakers start proposing tax hikes, they will have a battle on their hands

Lt Gov Posthumus knows this, and so does his opponents for the governor and in the media. They know that Dick Posthumus is on the right track and they are scared

Diane Detter lives in Farmington Hills.

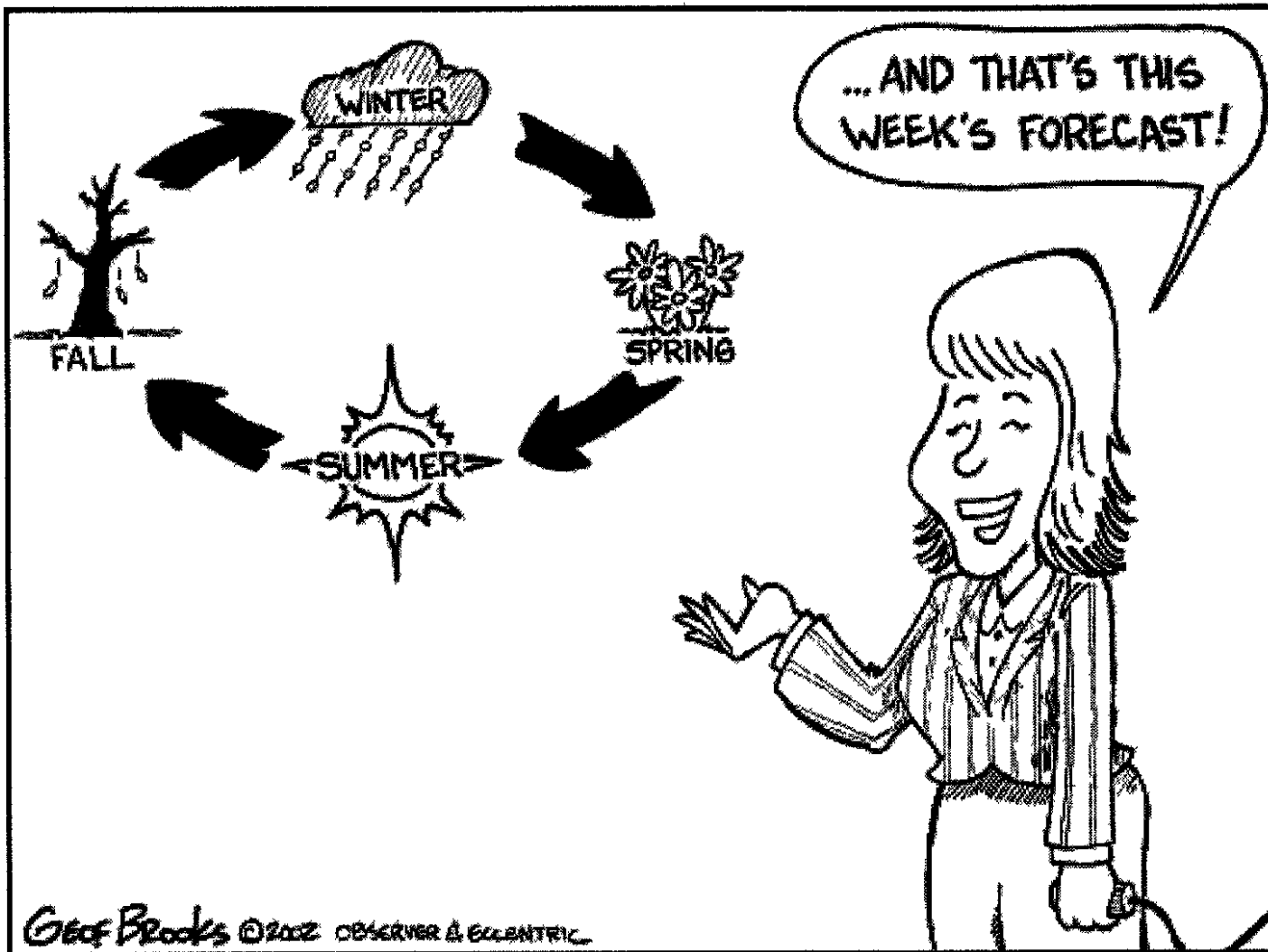

LETTERS

Shaping debate?

In the article in Sunday's Plymouth Observer (Budget forces school layoffs) the Observer advises us that the layoff of 19 Plymouth-Canton teachers is the first wave of budget cuts to achieve a \$1 million dollar cost savings. We are also advised that Kathleen Booher doesn't feel that Republican Gov Engler's \$200 per-child increase in the state foundation grant next year is enough

The Observer finally advises us in the very last paragraph of the article that Booher has stated that "We would call some back if we have more retirements, other leaves, or more students register for classes than we're projecting." So perhaps what it really is is that the district projects to have less students in 2002-2003 thus requiring less teaching staff?

The April 18 Canton Eagle newspaper carried an article on page A-5 headlined "District has a surplus." That article advises that the district Finance Director Patricia Brand told the school board that the school would not run a deficit this budget year, but would in fact end up with a surplus of \$11,850,191 — almost \$12 million dollars. School Board President Laz Givens is quoted in that same Eagle article as stating "That is an excellent financial forecast."

Last Thursday the Observer advised us that the school board vice president, who has championed the overthrow of taxpayer-approved Proposal A, is going to run on the Democrat ticket for a state representative seat. Additionally, the MEA endorsed Democrat Jennifer Granholm for governor Saturday

Is the Canton Eagle making all that budget information up and quoting PC district officials out of context, or could it be that the Observer and Kathleen Booher are attempting to shape the debate in favor of overthrowing Proposal A and electing a few tax-and-spend Democrats this fall?

*Mark F. Tooze
Plymouth Township*

Thank you

The Plymouth Jaycees would like to thank the following sponsors for their generous donations to our Easter Egg Hunt on March 30, 2002

- Plymouth — Dr Gary Hall D D S, Busch's, Kroger, Lou LaRiche Chevrolet
 - Canton — Richardson's Super Drug, Meijer, Target, Kroger, Super Kmart, Girl Scout Troop #915
 - Livonia — Century Novelty Company, Wal-Mart
 - Dearborn Heights — JoAnn Fabric
 - Personal — Debbie Baudino, Ed Kandah, Tony Rubino
- We would also like to announce the winner of the scooter — Anthony Kmieck

Plymouth Jaycees

Who are we?

The Transportation Department of Plymouth-Canton Schools is one of the most valuable assets in our community. The people involved in taking your children to and from school are one of the most precious groups we have around us

Work at the bus yard starts between 5-5:30 a.m. while most families are still fast asleep in their beds. It's still dark outside. At times you can still see the moon and stars. The roads are almost empty of cars. The weather conditions could be horrific with ice, snow and sleet

or absolutely beautiful, depending on the season

Some winter months we are out before the salt trucks, springtime, before we have been alerted of 50 mph winds!

We usually know before anyone that a traffic light is out or where the black ice is or that a car is in the ditch, or an animal has been hit and needs help, downed electric wires, etc. We are the first to know and see most everything going on in the early hours of the day. The bus yard lights are on along with the bus garage. Over 100 buses are getting ready for the journey of picking and dropping off your most precious possessions — your children

One by one we pre-trip our buses which includes entire inspection of the bus from outer to inner to under the bus. Everything must be perfect during the pre-trip or the bus doesn't leave the yard

Sometimes drivers see and report situations that have just happened that police and fire departments are not yet aware of. These drivers reports are called into dispatch, who, in turn, call the proper authorities. They have probably saved some lives, patrolling your community day and night during the bus route drive

We have many substitute drivers to accommodate routes when drivers call in sick. They are very efficient and well trained

Drivers and staff are all dedicated to making things run as smooth as possible. Drivers and staff are so proud and happy when they are able to turn a bad situation into a good one with the children

Drivers have sick children. Calls are made to dispatch and parents are called and school principals get involved in getting your child the help they need

Drivers have small children who miss their stop on the way home. Drivers contact dispatch to notify this and that if parents call, the child will be dropped off a little later than usual and not to worry

Special Ed drivers are the greatest people. They are transporting some children who are terminally ill and drivers are truly affected by their early departures

Drivers in conversation call the riders, "My kids." They are proud of "Their kids." They brag that the kids on their bus "are the best" and "their kids are polite and good to them." They like bragging about "Our Kids"

If you have a concern or any questions regarding your child's bus ride, please feel free and comfortable to call and ask to talk to the staff at (734) 416-3000. They all are very wonderful people anxious to please. They are good listeners. No concern is too small

Be kind to the staff when you call. They care about your children. They are your best friends

All transportation drivers and staff are a wonderful group of people who love their jobs and love your children. Be good friends, call as often as needed. We are one big family when it comes to caring and protecting your children. The Plymouth-Canton transportation group reminds me of "Guardian Angels"

*A retiring bus driver
saluting Plymouth-Canton
Transportation
Lorraine Jones*

Give credit to author

I am writing in regards to the article "Students Quilt Messages of Love" that appeared on page C4 and continued on page C9 of the Thursday, April 11, issue

of the Plymouth Observer. In the cutline for the picture of Steve Bruestle's note (page C9), it was stated, "(he) shared his concern through a poem he wrote." I want to point out that these are song lyrics (Lonestar, "I'm Already There") and not the original words of the student. The quilt project was a worthwhile activity to convey these students' feelings for their teacher, however, I believe that credit should be given to the artists of this song and not the student

As a teacher for the Livonia Public Schools, we strive to teach our students that plagiarism is wrong. Although a few words were changed in this student letter, it is still plagiarism when credit is not given to the original source

I hope that the Observer will continue to cover stories like this, but in the future will thoroughly research items before they are included

*Shirley Kulisz
Livonia*

Good times?

Over three years ago, I wrote that in the year 2002 they would need 91% of the budget. I missed it by 1% as it is now 92% of the budget for salaries

Plymouth needs a new bus fleet and no money for replacement. Why isn't a reserve set up in the budget for replacements? It looks to me that property assessments will take a big jump in the coming years

I remember a couple of contracts ago that salaries were raised 7.5% each year for six years and the school board was thrilled that there would be no strikes. They were making 45% more at the end of the contract than they were making at the beginning

I do several retired teachers' income tax returns that make over \$100,000 in retirement along with social security and investments. Poor school teachers! They pay no Michigan income tax as their teacher's retirement income is tax free!

My clients that make over \$100,000 in retirement pay \$2,400 to the state

In today's news they are talking about laying off thirty-two teachers. Everyone brags about our school system and how great it is. Doesn't sound too great to me

I love prosperity if it is real but I don't think our good times are real today

*Dean H. Lenheiser
Plymouth*

Share your opinions

We welcome your letters to the editor. Please include your name, address and phone number for verification. We ask that your letters be 400 words or less. We may edit for clarity, space and content

Mail:
Letters to the Editor
Brad Kadrich
Plymouth Observer
794 South Main
Plymouth, MI 48170

E-Mail:
bkadrich@oe.homecomm.net

Fax:
734-459-4224

OTHER OPINIONS

Thursday, April 25, 2002

Local papers, readers owe a lot to Staley T. McBrayer

It was just a standard obit in last Saturday's New York Times. Staley T. McBrayer, who died at 92, was a smalltime Texas newspaper publisher and tinkerer.

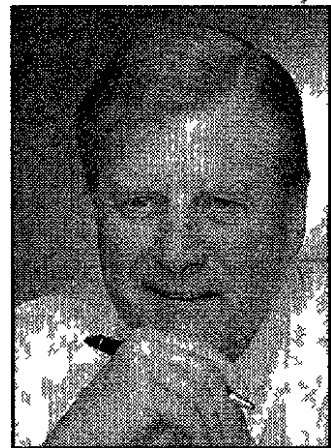

Phil Power

But McBrayer took an unwanted German press and figured out how to adapt offset printing technology to making newspapers. In so doing, he revolutionized the newspaper industry and made possible the success of hometown newspapers like this one. His life is conclusive evidence of how a small innovation can spawn profound consequences that were completely unimagined at the time.

McBrayer started out working as advertising and business manager of The Commerce Journal, a weekly newspaper in Commerce, Texas. After a while, he bought several other small newspapers in the Fort Worth area. But the salaries of the linotypists, who set in hot metal news stories and ads using a Rube Goldberg-like contraption called a Linotype machine, were "killing us," according to his partner, Jenkins Garrett.

So McBrayer and some employees in the back shop started tinkering around with how to set the type and print the newspapers cheaper than current technology allowed. They paid \$10,000 for a castoff press and figured out how to adapt offset printing to the production of newspapers. Abandoning the industry-standard but slow and clumsy Linotype machine, they perfected "cold type" photographic typesetting. Then they learned to transfer the image of a newspaper page to a thin metal plate. Ink adhering to the images on the plate was transferred — offset — to a rubber blanket which then transferred the image onto newsprint. And, eureka, offset printing!

At that time, most newspaper press manufacturers believed offset would never click for the fast rotary presses required to print newspapers. But the technology worked. Within 30 years after McBrayer's first press was developed in 1954, virtually all the newspapers in America were printed by offset.

His invention made the skills — and the high wages and the workplace stranglehold — of Lino type operators irrelevant, thereby setting off a

long, fierce struggle over the future of linotypists and other workers in the letterpress crafts.

"Cold type" typesetting was far easier, quicker and cheaper than the old "hot type" system. For example, when I started out in this business back in the 1960s, I used to write my column on a Linotype machine. If I was really flying, I could set it in around an hour. Today, I'm writing this column on a computer, which transfers the file to a phototypesetter that converts bits and bytes to readable copy (I trust) in seconds.

Since photographic negatives were cheaper, more maneuverable and easier to use than heavy trays of lead type, newspapers using offset technology could join together to set type and print in cooperative plants. The cost savings were considerable.

Moreover, because photographic typesetting was so much faster and cost efficient than hot type methods, home town newspapers like this one could localize their coverage economically, focusing on one community at a time without having to jumble local news from several different towns into a big regional newspaper like the metropolitan daily newspapers still do.

I never met Staley T. McBrayer; indeed, I had never heard of him before I read his obituary in The New York Times. But I owe him a great debt of gratitude. And so do countless readers whose lives are enhanced by reading their hometown newspaper like this one.

So the community newspapers, arguably the most innovative and entrepreneurial part of the newspaper industry, really got their start as a result of Staley T. McBrayer's innovative genius way back in the mid 1950s. Like many of my publisher colleagues, I adopted phototypesetting and offset printing in my newspapers in the late 1960s.

I never met Staley T. McBrayer, indeed, I had never heard of him before I read his obituary in The New York Times. But I owe him a great debt of gratitude. And so do countless readers whose lives are enhanced by reading their own hometown newspaper like this one.

Phil Power is chairman of HomeTown Communications Network Inc., the company that owns this newspaper. He welcomes your comments, either by voice mail at (734) 953-2047, or by e mail at ppower@homecomm.net



Mike Malott

Michigan unique in debating issue of judicial activism

"We are dealing with only the hairballs, if we are doing our job right," said Michigan Supreme Court

ers here, having had a chance to decide between the two schools of judicial thought, chose to keep the traditionalists.

I'm not convinced. Once voters get a chance to view the traditionalists in action, I think, they may have a different reaction.

It's fine to argue, as Young does, that the law is just what it says it is in writing when you are talking about legislation that applies to the general public.

Provisions that limit government, such as those in the constitution, I think should get a broader view.

We've all dealt with the used car salesman who can come up with a contract that appears to say one thing, and then treats it in a completely different way once the signatures have been placed on the dotted line.

In fact, the law recognizes that contracts can be "deceptively written." Contracts written in that way are prohibited under Michigan law.

But the "constitutional traditionalist" philosophy, in my view, lets the used car salesman get away with his fraud.

We saw it in the Supreme Court's most publicized case last year, its ruling on the new concealed weapons statute. We all thought we had a right to referendum, the ability to petition to overturn laws passed by the Legislature. But lawmakers found a loophole, an exception for bills that allocate money.

The "traditionalist" majority on the court interpreted the words of the constitution literally, and thus found that it was irrelevant that a "legislative subterfuge" was being used. The constitution doesn't stop "the legislature from capriciously exercising its power of appropriation," they said.

Scary stuff from a court whose job is to be the final say on a document like the constitution, written in large part to place controls and limits on what government can and cannot do.

Young has to run again this fall. He'll be on the ballot along with Justice Elizabeth Weaver seeking re-election.

So the debate over traditionalism versus judicial activism will continue. And it should.

Mike Malott reports on the local implications of state and regional events. He can be reached by phone at (517) 548-7125 or by e-mail at mmalott@homecomm.net.

Justice Robert Young Jr.

In Howell to talk to Livingston County Teenage Republicans on their Legal Career Day, he also took a few minutes to chat with journalists of the HomeTown Communications Network.

He was explaining about the quiet revolution the current Supreme Court majority is taking our state through. Calling himself a "constitutional traditionalist," he believes the "judicial activism" of justices in the past has made for an inconsistent application of the law. Only if the court interprets the constitution and laws literally — according to just what the words are as they have been written down on paper — will the rest of us really know what our rights truly are, he said.

Activism — the philosophy in which judges try to decipher the meaning of the laws, as Young describes it — has led to inconsistent rulings and case law. So the rest of us can't really be sure how a judge will rule in a given case once it reaches the trial stage.

What the Supreme Court is going through is a process of "judicial hygiene," said Young.

And that's where the hairball analogy came in. "These are the areas where the fabric of the law has become gnarled, the fabric itself frayed, and our job is to go in and say, 'no, this is the pattern,' so that you can understand what the next step in that pattern will be."

"So we are dealing with the hardest cases in the state, and to do it fluently, in understandable English, to do it persuasively, and to have a comprehensible result is a very high goal of this court."

Young's conservative view of the role of the judiciary — interpreting what the law says, not what it should be — was the big issue in the race for the Supreme Court in the 2000 elections. He contends Michigan is unique among states in having dealt directly with it. He gives credit to Gov. John Engler — one of the few governors, according to Young, who really understands the issue — as having brought it to the fore through his appointments to the bench.

Of course, Young also feels the outcome of the election vindicated his traditionalist views. Vote

SOLID OAK

Now 50% Off

A MIDWEST TRADITION

with a 42" pedestal table. Has 1 - 18" leaf, 4 matching bow back chairs, and with a 10 year chair warranty.

5 PIECE SET
REG. \$1399.00

SALE \$699⁰⁰

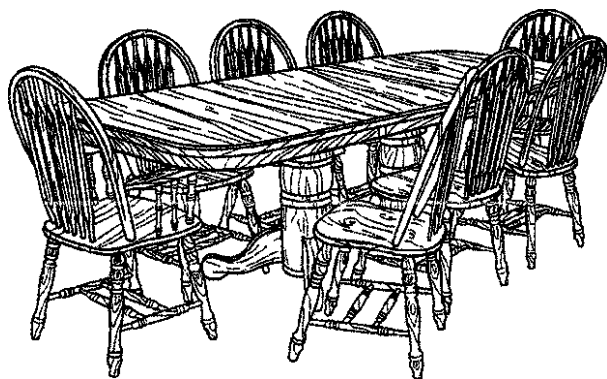
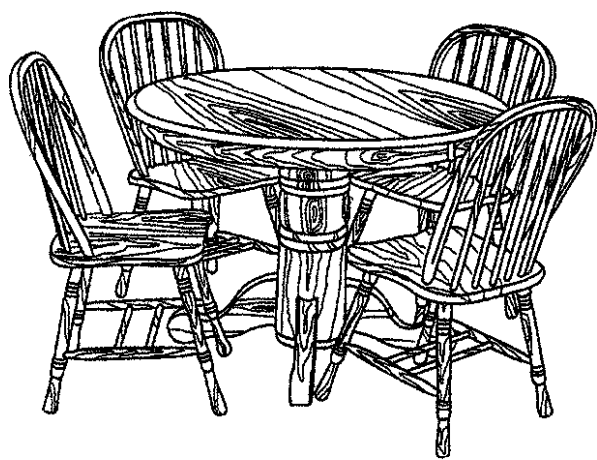

10 YEAR
CHAIR WARRANTY

Timeless beauty... Enduring Value

with a 42x60 table,
2-12" self storing leaves,
6 large bow back side chairs.

7 PIECE SET
REG. \$2399.00

SALE
\$1199⁰⁰

DO NOT PAY FOR ONE FULL YEAR!

NO DOWN PAYMENT - NO INTEREST - NO PAYMENTS TILL 2002
\$1000 MINIMUM PURCHASE WITH APPROVED CREDIT

Tempenny's

LIVONIA 32104 Plymouth 421-6070	SOUTH LYON 124 N. Lafayette 437-1590	HOWELL 2700 E. Grand River 546-7420
---------------------------------------	--	---

CHERRY & OAK
FURNITURE

HOURS: 10-9 Daily; 12-5 Sunday



YOU HAVE ARRIVED

BRIDAL SHOW

THE 2002 BRIDAL SHOW

MAY 3RD THROUGH MAY 5TH
NOON-7PM, SOMERSET SOUTH ROTUNDA

Find out how we can help make your dreams come true at our showcase of extraordinary wedding fashions, accessories and gifts. Heavenly ideas from more than 80 fine stores. Available through our Registry at Somerset. You have arrived.



THE REGISTRY
AT SOMERSET

SOMERSET
COLLECTION

NEIMAN MARCUS SAKS FIFTH AVENUE NORDSTROM MARSHALL FIELD'S
AND MORE THAN 180 OTHER UNIQUE SHOPS AND RESTAURANTS
FOR MORE INFO LOGON TO WWW.THESOMERSETCOLLECTION.COM

Commission takes Metro fight to court

BY KURT KUBAN
SPECIAL WRITER

The ongoing battle between the Wayne County Commission and County Executive Ed McNamara over future control of Metropolitan Airport intensified this week, and has even threatened the future of a massive mixed use development south of the airport.

On Monday, the commission filed a lawsuit in the U.S. District Court in Detroit challenging the legality of the state Legislature's decision last month to transfer the license to operate Metro and Willow Run airports away from the county to a seven-member independent authority.

According to Senate Bill 690, which was endorsed by McNamara and signed into law by Gov. John Engler March 26, all seven members of the authority are to be appointed, four by the Wayne County executive, two by the governor, and one by the commission.

While McNamara and Engler have already appointed six members to the authority, the commission has refused to appoint the final member.

Authority meets

Despite the lawsuit and the lack of a seventh member, the authority held its first public meeting Wednesday at Metro's Marriott Hotel. The authority's first action was to name itself the Wayne County Airport Authority.

Named in the commission's lawsuit are McNamara, Engler and the Federal Aviation Administration, which must approve the transfer of power to the new airport authority. The commission is also expected to file a restraining order today in federal court to prevent the FAA from making a decision until the court hears the lawsuit.

According to Commissioner Kay Beard, who represents Westland, Garden City and Inkster, McNamara and Engler had no right to go around the commission and strike the deal that led to the formation of the authority.

"The idea to give seven people that kind of authority without ever having any public hearings is unlawful. These people are all



Ed McNamara

appointed, which means they will not be accountable to the tax payers of this county," she said.

McNamara said he disagrees with the commission's lawsuit, because the county has no choice but to abide by the actions of the state Legislature.

"I don't think the commission understands we are creatures of the state Legislature," he said. "They are wasting their time and county dollars with this lawsuit. It is a desperate act."

According to McNamara, the new authority will run the airport much more efficiently than the commission, which he doesn't believe has the business savvy to do the job.

"The people on the commission don't have a lot of business training, whereas the members of the authority have long careers and success in the business world," he said.

"Governor Engler and I have worked hard to make sure we have proven leaders on this board. These individuals will give the airport the leadership and direction to function as a business does and become a competitive powerhouse for this region and this state."

Development stalled
The feud between McNamara and the commission over operations at the airport is spilling over into the development of the Pinnacle Aeropark of Wayne County, a 1,300-acre mixed-use development just south of Metro Airport in Romulus and Huron Township. If completed, the Pinnacle will be the biggest development of its kind in the state.

More than a year ago McNamara asked the commission to approve the creation of an authority to oversee the county-owned development but the commission has refused to vote on the issue. McNamara said the



Kay Beard

commission's failure to act could mean losing as much as \$60 million in state funding for the project.

"This is the second most important project in the state, and the commission walked away from it," he said.

Commissioner John Sullivan, who represents both Romulus and Huron Township, as well as Canton, said the mistrust between the commission and McNamara over the airport has been a factor in the commission's lack of action on the Pinnacle project.

"That's definitely part of it. Some of our legal counsel has said creating an authority for this project will look bad in our fight against the airport authority. But I feel this is a totally different ballgame. I just don't see how it is going to hurt us with the other issue," he said.

"Personally, I've always been in support of this project. But I'm not sure we have enough votes to get it approved. Whatever the case, I think we need to move forward. Either we're voting for it, or we're not."

Beard said McNamara hasn't given commissioners enough time to fully evaluate the issue, and doesn't believe there should be a vote until they do.

"We're not elected to be a rubber stamp for Mr. McNamara. It is our responsibility to carefully weigh the issues in front of us and vote on them. If we were to do any less, we would be neglecting our duty to the people who elected us," Beard said.

Kids on Campus starts July 8

If you're already wondering what to do with your youngsters over the summer, consider enrolling them in Schoolcraft College's Kids on Campus program, with two-week sessions beginning July 8 and July 22. Participants choose from a wide variety of enrichment classes in math and science, computers and electronics, creative and performing arts, languages and "Kids on the Scene" classes.

Mail-in registration is in progress now and walk-in registration begins May 6. You can view or download the Kids on Campus catalog and application form by going to the Schoolcraft Web site, www.schoolcraft.ct.mi.us, clicking on Kids on Campus under Continuing Education, and clicking on "view a class schedule."

Schoolcraft College is located at 18600 Haggerty Road, between Six and Seven Mile roads, just west of I-275.

Classes are grouped for grades one and two, three and four, five and six, and seven, eight and nine. There is even a class for parents, Feed the Brain for Learning, examining the latest information on the relationship between diet and the brain.

New classes this summer include Pantomime & Mask Fun, Who Wants to be a Musical Millionaire, A Pocket Full of Poetry, Rockin' Through the Ages II and Around the World in Eight Days.

Most classes meet for two hours, four times a week, and cost about \$100 for regular classes and \$200 for special all-day camps. Two new day camps are Science Sleuth and Earth Day Everyday.

VARSITY
3480 Jackson Rd. 1-800-875-FORD
ANN ARBOR

BRIARWOOD
7070 Michigan Ave. 734-429-5478
SALINE

ATCHINSON
9800 Belleville Rd. 734-697-9161
BELLEVILLE

HINES PARK
I-96 at Milford Rd. 248-437-6700
LYON TWP.

GENE BUTMAN
2105 Washtenaw 734-482-8581
YPSILANTI

FRIENDLY
1011 S. Monroe 734-243-6000
MONROE

OPEN SATURDAYS

GET **0%**

AND SAVE UP TO

\$2,900

APR FINANCING FOR UP TO 60 MONTHS(1) **IN FINANCE CHARGES (1)**

ON 2001 AND 2002 EXPLORER 2DR. SPORTS

2002 EXPLORER 2DR. SPORT

0% or \$2,500
financing cash

2001 EXPLORER 2DR. SPORT

\$3,250 or 0% plus \$750
cash financing cash

NO BOUNDARIES FOR OUTSIDERS

SUBURBAN FORD DEALERS
OPEN SATURDAYS

(1) NOT ALL BUYERS WILL QUALIFY FOR LOWEST APR see dealer to see if you qualify. 0.0% Ford Credit APR financing for qualified buyers on 2002 and 2001 Explorer 2dr Sports varies by creditworthiness of buyer as determined by Ford Credit. Finance savings based on MSRP for a 2002 Explorer 2dr Sport financed for 60 months at 0.0% APR with \$0 down payment compared to the 3.9% APR 60-month rate available prior to April 9, 2002. Actual savings will vary with amount financed. Dealer participation may affect savings. For special APR financing or cash back offers \$2500 on 2002 Explorer 2dr Sport \$3250 or \$750 plus 0.0% APR on 2001 Explorer 2dr Sport take new retail delivery from dealer stock by 5/1/02. Supplies are limited not all dealers will have all featured models. Residency restrictions apply. See participating dealer for complete details.

WHAT'S NEW

Rifle-front tee from Awake. Turquoise, lime, orange or black. Sizes S-XL. \$39.

Jacobson's

MON SAT 10 9 • OPEN SUN AT NOON

Birmingham • (248) 844 6900 Livonia • (734) 591 7698
Rochester • (248) 851 6000

jacobsons.com

PDF 0598

ARTS & ENTERTAINMENT

Thursday, April 25, 2002

ARTISTIC EXPRESSIONS



LINDA ANN CHOMIN

Young pianist happy to be home again

It's not that Sanjay Mody doesn't love Paris. Who wouldn't enjoy going to the Louvre or attending concerts whenever you feel like it? Culture is everywhere but after nearly a year away from his Birmingham home the young pianist longs to spend time with his friends.

Mody is eager to tell them all about his adventures. He has plenty of stories about preparing for the entrance exam to the Paris National Superior Conservatory of Music after studying since June with graduate level piano professor Marie Francoise Bucquet. In March, Mody passed with flying colors, placing first among 200 applicants.

The 15 year old returned to Birmingham at the beginning of April for a four week stay. He's wasting no time reacquainting himself with students at the Roeper School in Birmingham and Schoolcraft College in Livonia where he studied piano from the age of 9 with Donald Morelock. Before leaving, Mody will perform a Chopin concerto with the Livonia Symphony Orchestra on Saturday, April 27.

"I'm sad about returning," said Mody. "I really miss everyone. You can get over a lot of things but that's really hard. I don't really speak French well. All my classes will be in French starting in September but I'm not worried. Music is an international language and my piano instructors speak English very well. I just wish I had all my friends here over there. They've asked me if I regretted moving. I said 'no' because I'm going to get to visit more."



STAFF PHOTO BY JIM JAGDFELD

In concert: Sanjay Mody will perform Frederic Chopin's Concerto No. 1 in E minor for piano and orchestra.

Traveling has become a way of life for Mody who for the past six summers has studied in Russia through a piano institute organized by Schoolcraft College. In fact, Mody won first place in the International Shostakovich Competition, an educational element of the institute in St. Petersburg in 2001.

"Paris, musically speaking, is very different from Russia," said Mody. "There are so many different

Please see CHOMIN, B9



Festival serves up films for reflection

BY LINDA ANN CHOMIN
STAFF WRITER
lchomin@oe.homecomm.net

What would have happened if Hitler had won the war? David Magidson throws out the premise of *It Happened Here*, an underground classic in the fourth annual Lenore Marwil Jewish Film Festival presented by the Jewish Community Center April 28 to May 8.

It's half past nine on a Tuesday morning and Magidson, between bites of breakfast, wonders as film director Kevin Brownlow did what the fate of Jews would have been in England where the movie takes place. He pauses to reflect.

As festival director, Magidson and a committee spent hundreds of hours reviewing more than 100 films for the thought-provoking content found in Brownlow's film that took six years to

'These are well-made movies about important issues. I don't think there's a bad movie in the bunch. It's difficult to find 25 movies for general entertainment let alone to find 25 good Jewish movies.'

David Magidson
Festival director

make in the late 1950s and early 1960s. Brownlow allows British fascists to share their views of the Jews, sounding warning bells nearly two decades after World War II.

Of the 25 films showing at theaters in Birmingham, Commerce Township and Ann Arbor, the majority deal with historical events and the struggles of Jewish people in Europe and the U.S.

Magidson begins to list the highlights of the festival — *One of the Hollywood Ten* stars Jeff Goldblum as Herbert Biberman in a fictionalized feature about the period in American artistic/political history when writers were blacklisted.

"These are well-made movies about important issues. I don't think there's a bad movie in the bunch," said Magidson, a Bloomfield Township resident. "It's difficult to find 25 movies for general entertainment let alone to find 25 good Jewish movies."

Jewish Film Festival

- **When:** Sunday, April 28 to Wednesday, May 8
- **Where:** United Artists Theatres, 14 Mile Road at Haggerty, Commerce Township, Birmingham 8 Theatre on Old Woodward Avenue south of Maple, Birmingham, and the Michigan Theatre, 603 E. Liberty, Ann Arbor
- **Tickets:** \$8-\$7 seniors, festival pass for all movies \$89, \$79 seniors call (248) 788-2900



Now playing: "One of the Hollywood Ten" (above), "The Power of Good: Nicholas Winton" (below), and "Good Evening, Mr. Wallenberg" (film strip left to right). "The Times of Harvey Milk," "Hester Street," and "To Be or Not to Be" are highlights of the Lenore Marwil Jewish Film Festival.

Guest speakers

Not content to send audiences home thinking about what they've seen, the film festival committee has invited guest speakers such as U.S. Rep. Barney Frank (D-Mass.) who brings contemporary issues such as homosexuality to the forefront. Frank will answer questions after showings of *Let's Get Frank*, a film currently in production and featuring him as one of the openly gay politicians who are Jewish, and *The Times of Harvey Milk*, an Oscar-winning documentary. The film chronicles the life and murder of Milk, a San Francisco supervisor who was gay and Jewish, and Mayor George Moscone of San Francisco. Filmmaker Bart Everly will lead the discussion along with Frank.

Producer/director Monique Schwarz is traveling from Australia to talk about *Mamadrama*, a documentary

that challenges the way Jewish mothers are portrayed in film. The film dispenses negative stereotypes of Jewish mothers as controlling, manipulative and guilt-inducing.

Magidson expects movies like these to draw even larger crowds than last year. In anticipation of the demand to see *In Search of Peace Part One 1948-1967* and other films in the festival, the committee expanded the number of venues from one to three. *In Search of Peace* brings the history of the founding and defending of Israel to life. Narrated by Michael Douglas, the film is a timely documentary in light of the current conflict in the Middle East.

The Power of Good: Nicholas Winton is sure to attract hundreds of viewers as well. The documentary about an Englishman, who saved 679

Please see FESTIVAL, B6

EXHIBIT

Farmington Festival of the Arts

What: Art exhibit and performances, demonstrations and music
When: Sunday, April 28-Sunday, May 5
Where: William B. Costick Center, 28600 Eleven Mile, in Farmington Hills
Details: Stary Night Gala opening on Saturday, April 27, Mighty Meaty Swing Kings in concert, May 4. For information,

BY JONI HUBRED
STAFF WRITER
jhubred@oe.homecomm.net

Connie Lucas projected her dreams of a far off land onto canvas then found herself in a dream come true winning the Farmington Artists Club's Spring 2002 juried exhibition.

Held April 10 in conjunction with the Farmington Artists Council at the William B. Costick Center in Farmington Hills, the event drew 259 entries from artists from all over the metropolitan area. Veteran artist Jim Pujdowski spent 90 minutes and used

'The technical achievement is just outstanding. I like the idea, I like the composition.'

Jim Pujdowski
Judge

a life time of experience to judge the show.

He named Lucas *I dream of Africa* Best of Show. Other awards went to Regina Dunne 2nd place (*Western Dreamer*/pastel), Julia McGrath 3rd

place (*Glory Be*/watercolor), Martha Barnes 4th place (*Wildflowers*/acrylic) and Jim Patterson-Grumbacher Award for best use of color (*Cathedral Shadow*/watercolor).

"You look for honesty first of all," Pujdowski said after awarding the top prizes "somebody true to their craft, whatever their medium."

Lucas, a Canton resident, used watercolor to combine elements of reality and fantasy in a bright array.

"The technical achievement is just outstanding. I like the idea, I like the

Please see EXHIBIT, B9

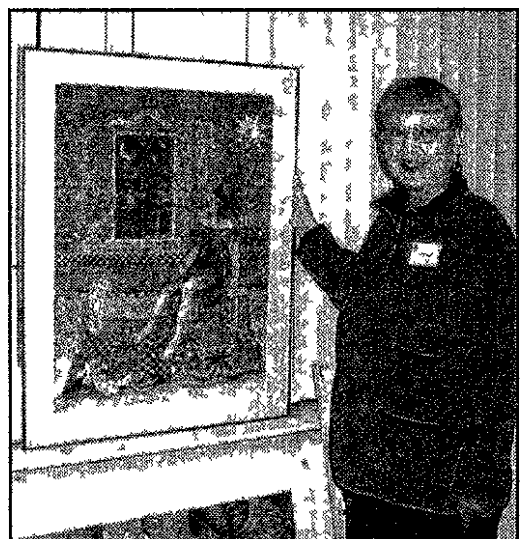

Artist's Dream: In juried competition, Connie Lucas earned first place for her watercolor, "I Dream of Africa."

sdargay@oe.homecomm.net

Seventies musical returns with a message of hope

BY LINDA ANN CHOMIN
STAFF WRITER
lchomin@oe.homecomm.net

The Meadow Brook Theatre stage is deserted as if waiting for the lively musical *Godspell* to bring it to life on opening night Saturday, April 27. It's lunchtime and one of the crews is taking a break from laying the floor, the first step in setting the scene. They've been working around the clock since *Cat on a Hot Tin Roof* closed on April 14.

Debra Wicks isn't worried about it coming together for previews Thursday-Friday, April 25-26. This is her second time directing the musical after acting in it four times. She knows Stephen Schwartz's music and lyrics. In fact, she'd probably still be performing in the John-Michael Tebelak musical if not for the realization that this is a show for young actors. The last time Wicks acted in the play was in a 1985 summer stock production in Missouri where she was working as a freelance actress.

"I got down in one of the dance positions and couldn't get up," said Wicks, who also serves as Meadow Brook Theatre's interim artistic director. Wicks hesitates to say how old she is but has spent the last 28 years acting and directing professionally and teaching at universities.

Meadow Brook Theatre

What: Present the 1970's musical *Godspell* with music and lyrics by Stephen Schwartz.

When: Previews, 8 p.m. Thursday-Friday, April 25-26, opens 6 p.m. Saturday, April 27, and continues through Sunday, May 19. Curtain 8 p.m. Wednesday-Saturday, 2 p.m. and 6 p.m. Wednesday, 6 p.m. Saturday and 2 p.m. and 6:30 p.m. Sunday.

Where: In the theater at Wilcox Hall, Oakland University, Rochester Hills.

Tickets: \$26-\$38, \$17-\$26 previews, call (248) 377-3300.

"You have to be physically fit to do *Godspell*."

"I love this musical. It makes me feel good. It's one of those musicals that resonates with people my age, baby boomers. We grew up with it. As humans we like to go to musicals. We're familiar with it. It's hummable and something parents can share with their kids."

Wicks chose the musical about the last seven days of Jesus' life because of its popularity since opening Off Broadway in 1971, and on Broadway in 1976. The underlying theme appeals to people of all faiths.

"What the play gives you is hope," said Wicks. "There's no

resurrection in the play. Whether the character is Jesus or not is not important. He is someone with a message of hope and willing to sacrifice himself for greater good. There's something I think everyone is thinking about."

Wicks is taking the musical to the rooftops of a big city to set the scene. Designer Peter Hicks's brick walls and vivid blue sky provide the perfect backdrop for the 10-member cast who start the musical in the audience and eventually leap up and down ladders on stage.

Ensemble

This is truly an ensemble piece and Wicks is grateful the casting was right before choreographer David Marquez and music director Leo Carusone, both New Yorkers, came on board. Wicks worked with Carusone last summer at Cherry County Playhouse in Muskegon where they put on *South Pacific* in seven days.

"It can be set anywhere - a junkyard, subway or playground," said Wicks who lived in the Bronx for three years while working as an actress in New York. "What you need is an open area and debris. I grew up on a farm. There's a different stress level in the city. People are looking for something or someone to make sense of it all. In a city if

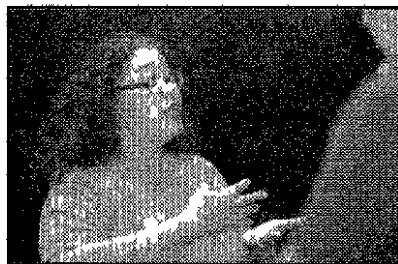

Director: Debra Wicks discusses the upcoming production of "Godspell."

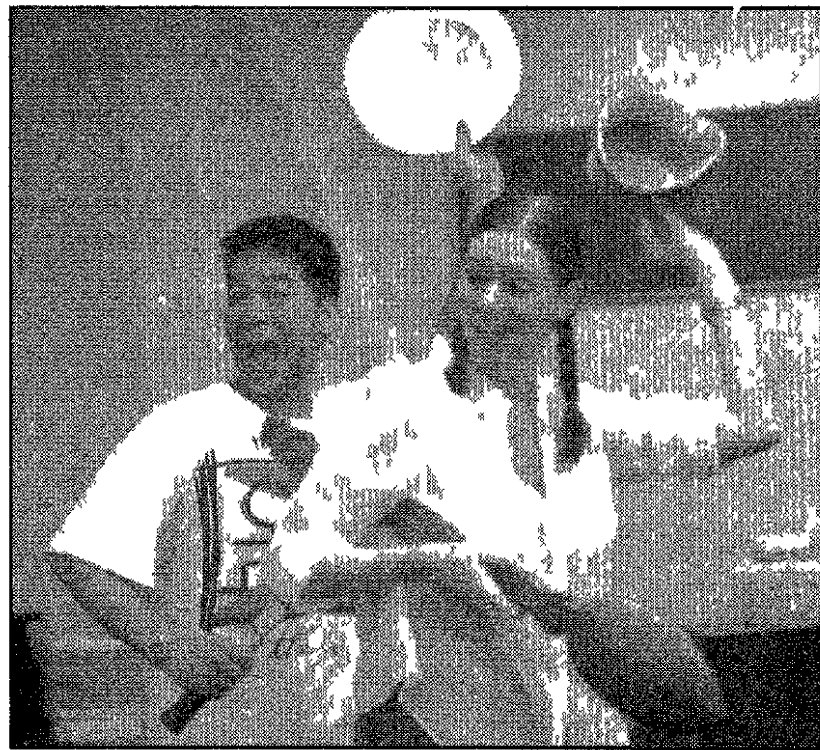

STAFF PHOTOS BY JOHN STORMZAND

Timely musical: Alonzo Luzod and Denise Costello rehearse for Meadow Brook Theatre's upcoming production of "Godspell."

you're going to go someplace to think it's up on the rooftop."

After rehearsing the cast six to eight hours a day, six days a week for the last three weeks, Joey Bybee agrees with Wicks that the rooftop is the place to be. The 21-year-old Pontiac actor enjoys moving around the stage as Herb, one of the characters. This is his first professional production, one he can list on his resume after graduating with a degree in musical theater from Oakland University in May.

"I wasn't familiar with *Godspell*," said Bybee who wasn't even born when the musical took Broadway by storm. "My roommate has every musical on the planet and I was playing it and fell in love with the music. Then we began rehearsals and I found it's a process of coming up with bits and fun things like doing voices of Maurice Chevalier."

Like Shannon Locke, Bybee thinks the reason the musical's remained fresh over the last 30 years is because it's based on improvisation.

Artistic freedom

"It's really an exercise in imagination," said Locke, who's understudying all the female roles.

"There's more artistic freedom because we're playing ourselves and get to improvise," added Bybee. "I like climbing around lots of levels on stage. I get to explore them all. I leap and perch. It's liberating."

It's the exact opposite for Denise Costello who's cast as the introverted Peggy. The West Bloomfield resident's been acting since age 11 in the performing arts program at Abbott Middle School and then at West Bloomfield High School where she did three shows a year and was president of the Thespian Society. She furthered her talent at Interlochen Arts Camp for

five summers before earning a bachelor degree in musical theater performance at Western Michigan University.

"I'm not a shy person so I have to be reserved until the point where she breaks out of her skin," said Costello. "What excites me about the show is the words are for everyone. It has a message of faith. For some it might be a message of hope. It's fun for two hours and keeps the audience asking more questions at the end."

While Alonzo Luzod appreciates what the musical is saying, he's more impressed with the quality of the production. The Farmington resident plays Jeffrey, an insightful character. In the past Luzod's performed with the Plymouth Canton Ballet Company and Tinderbox Productions based in Redford.

New season

The professionalism of the cast is what Wicks counts on year after year. It will be especially important to find the brightest talent next season when Meadow Brook Theatre

presents a variety of productions including *The Foreigner*, *Wait Until Dark*, the latest musical comedy *Meshuggah Nuns* by Dan Goggin, and Agatha Christie's *Witness for the Prosecution* which opens on Oct. 16. While Wicks is very excited about the Shaw Festival's January residency for a production of *Candida*, she can't stop talking about *A Thousand Cranes* which kicks off the theater's new Family Series on Sept. 28. The family-oriented shows continue with the return of the popular *A Christmas Carol* Nov. 29 to Dec. 22.

"It's a true story about a young girl who gets leukemia after surviving the bombing of Hiroshima," said Wicks explaining the plot of *A Thousand Cranes*. "She learns of the legend that if a person folds a thousand cranes a wish will be fulfilled and begins folding the paper birds. Even though she doesn't complete them, it turns into a wish for peace when school children finish the task. It's an exciting piece of theater, an important piece of theater for now. This is a lesson to be learned and relearned a lesson from 60 years ago we haven't learned yet. It's about the children - that they can make a difference. You can achieve anything if you put your mind to it."

Just For YOU
Oakland Community College presents
KATHY KOSINS

One of the most Alluring voices of Jazz will be appearing at the Oakland Community College Highland Lakes Campus

8:00 p.m., Friday April 26th, 2002
Oakland Community College Highland Lakes Campus, 7350 Cooley Lake Road, Waterford, MI 48327 in the Student Center Arena.

General Admission **\$10.00**
— Ample Parking —
For more information call (248) 942-3241

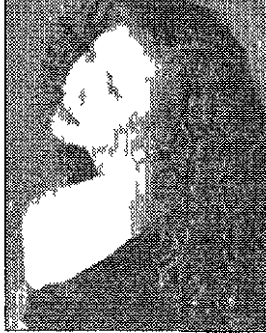

PLYMOUTH STAMP SHOW

Michigan's Largest Stamp Show
April 27 - 28, 2002
Sat 10 am-5:30 pm/Sun 10 am-4 pm

- ◆ APS National Accredited Show
- ◆ 2800 Pages of Stamp Exhibits
- ◆ 40 Dealers from U.S. & Canada
- ◆ Saturday Stamp Auction
- ◆ Seminars & Society Meetings
- ◆ Junior Program (free stamps)
- ◆ U.S. and U.N. Post Offices
- ◆ Cachet Covers & Show Cancel
- ◆ Free Admission & Parking

At
Plymouth Central Middle School
Church St. at Main St.
Downtown Plymouth, Michigan

FREEDOM HILL AMPHITHEATER
SUMMER 2002
The Hill is Alive with the Sounds of Music

This summer, watch the stars come out at the "new" Freedom Hill Amphitheater. Enjoy your favorite entertainers in comfort and style with:
* extra wide pavilion seats
* plenty of legroom * great sight lines * a new state-of-the-art stage * and an all new concession concourse.

Freedom Hill Amphitheater
Where the Stars come out at night!

THE **Observer & Eccentric** NEWSPAPERS present **Oldies 104.3 WOLC**

Super 60's Rock n' Roll Show
starring **The Turtles** featuring Flo and Eddie and **Paul Revere and the Raiders** with special guest **Grass Roots**

Tickets Available thru Freedom Hill Amphitheater Ticket Office
ticketmaster
248 645-6666
www.ticketmaster.com
Marshall Field & Mail Harmony Station

For Season Tickets or general information call 588-268-5100
M-F 10am-6pm, Sat. 10am-4pm
www.freedomhill.net

Tickets on Sale Now! Starting at \$15
Children's Series \$30 (\$15 off the regular ticket price when you buy the series)
All shows and dates are subject to change

FRIDAY, JUNE 7, 2002
8:00 p.m.

ON SALE NOW!
Freedom Hill Box Office and Ticketmaster 1-248-645-6666

A Quality Concert Production

PROM DIRECTORY

With Prom night right around the corner for many Junior and Senior High School students, this is the place to look for companies that know how to make that special dance the best memory possible!

For information regarding this special promotion please contact **Dylan Bawulski at (734) 953-2073**

Ann & Belm Accessories
specializes in beautiful designer handbags and other prom accessories
Bring this ad in for a 10% discount

The Product Shop
offers a "FREE" Achievement Certificate and 10-15% off when you purchase \$25.00 or more off of our Graduation Line
Call 248 426-9995 for more information or stop by Lvon a Mall in Merivyn's Court

Prom 2002
Get your **TUX BUCKS**
Discounts up to **50% off**
Your Tuxedo Rental!
Rentals Starting at \$54.99! (with minimum discount)

President Pluxedo
What you Wear to Prom!
Michigan's Largest Formalwear Company
35 Stores in Michigan & Ohio
www.presidenttuxedo.com
1 800 837 TUXS

comcast

ROYAL HANNEFORD

CIRCUS Presented by **MEIJER**

8 SPECTACULAR PERFORMANCES!

Thursday, May 9 • 7:30 PM
OPENING NIGHT ALL TICKETS \$4!

Friday, May 10 • 11 AM & 7:30 PM

Saturday, May 11 • 10:30 AM, 3 PM & 7:30 PM

Sunday, May 12 • 1 PM & 5 PM

Co/Op Optical, AT&T Wireless, Hilton Suites Auburn Hills, GREAT LAKES CASSETTE, NORTHWEST

PALACE
TICKETS at PalaceTel.com THE PALACE BOX OFFICE AND ALL **ticketmaster** LOCATIONS CHARGE AT 248 645-6666.
DISCOUNTS AVAILABLE FOR GROUPS SENIORS & KIDS CALL 248 377-0100 FOR INFORMATION

AUDIO BITES

C'MON C'MON - SHERYL CROW

Thank goodness for the skip button

It'll get a workout when listening to Sheryl Crow's latest release, *C'mon C'mon*. About half of the tunes are worth hearing, the rest should have been left on the cutting-room floor.

Musically, *C'mon C'mon* has no cohesiveness. Numerous guest stars don't help the album gel.

Lyrical, Crow doesn't score points for originality with lines such as "life is what happens when you're making plans" — a line recorded by John Lennon more than 20 years ago.

Equally insipid is this painful couplet: "I'm just like the weather/I keep changing my mind."

The album opens promisingly enough with *Steve McQueen*, a tightly knit three-minute rocker. And the next song, *Soak up the Sun*, is a catchy Beatlesque ditty that benefits from backing vocals

courtesy of Liz Phair

But the Don Henley duet on *It's So Easy* sounds like it was cut at a karaoke bar by pop-star wannabes.

Speaking of karaoke, why is Gwyneth Paltrow singing on *It's Only Love*? Thankfully, her vocals are so low in the mix it could be Miss Piggy singing and no one would be the wiser.

The best song on the album is its last, *On Weather Channel*. Crow turns down the volume and finds an easygoing vibe with the help of Emmylou Harris.

But Crow's uneven effort leaves the listener in awe one minute and screaming 'C'mon!' in frustration the next.

— Scott Bauer, AP Writer

HEART TO YOURS - MICHELLE WILLIAMS

R&B artists usually don't venture into gospel music at the height of their careers, generally, it's a step taken when their secular careers are losing steam.

Michelle Williams of Destiny's Child bucks the trend with her debut solo project, the gospel album *Heart to Yours*. But it seems Williams is not ready to fully shed her secular influences.

Dance beats abound on this album, making it sound more like a Destiny's Child remix record than a religious disc. *Heard a Word* would be unrecognizable as a gospel record if it weren't for the occasional utterance of the word "Lord." In addition, the song *Rock With Me*, with its wailing electric guitar, is a little much here.

The disc even features Destiny's Child doing the same *Gospel Medley* that's on their own *Survivor* disc, an odd choice because it serves as a vocal showcase for lead singer Beyoncé Knowles, not Williams.

The song selection only underscores the album's main problem — Williams is no Knowles. She cannot deliver vocally — her voice is too nasally and often

sounds whiny

It's no surprise that the better songs are *So Glad* with Mary Mary and *Steal Away to Jesus* with Shirley Caesar. These artists overpower Williams, and make you realize what real gospel singers — and music — should sound like.

— Jennifer F. Bogar, AP Writer

HAMMERED - MOTORHEAD

Motorhead's new album, *Hammered*, is a metal primer for budding rock bands. It provides a "how-to" on metal-music basics — and some good lyrics.

This band has been around since 1975, so these guys are more grizzled than a biker-bar regular — which is exactly their appeal.

Brave New World is a layman's take on the state of the world corrupted by power and greed. It has the fast pace and guitar growl of the band's better-known songs such as *Ace of Spades* and *Eat the Rich*.

Down the Line is a good tune

about getting out of a stagnant relationship. It's the closest thing to a love ballad that lead singer/headbanger Lemmy Kilmister can muster.

Kilmister will always be the force behind Motorhead. His vocals are still limited to strained yelps, but there's musi-

cal sincerity when he belts out lines such as "And religion, like the monster that it is/Keeps telling you to turn the other cheek/God is on your side, but I don't think that you're on his/If Jesus showed up now he'd be in jail by next week."

— Ron Harris, AP Writer

Meadow Brook announces 2002-3 season

The Great Lakes premiere of the newest *Nunsense* musical comedy and the initiation of an international residency with the Shaw Festival of Canada will mark Meadow Brook Theatre's 2002-2003 season.

Meadow Brook's 37th season will also introduce a new series of theatrical productions designed to school audiences and families.

Subscriptions are currently on sale of the 2002-2003 season and are available through the Meadow Brook Theatre Box Office, (248) 377-3300. For group and school matinee information, call (248) 370-3316. The theatre's Website is www.mbttheatre.com.

"Meadow Brook Theatre will produce an exciting season, created to make theater come alive for each member of our audience," said Debra L. Wicks, interim artistic director.

Agatha Christie's *Witness for the Prosecution*, will open the new season Oct. 16. The popular

courtroom mystery will run through Nov. 10.

The internationally acclaimed Shaw Festival has announced a rare U.S. residency with Meadow Brook Theatre. Based in Niagara-on-the-Lake, Ontario, the Shaw Festival is renowned for its productions of the works of George Bernard Shaw (1856-1950) and his contemporaries. Jackie Maxwell, artistic director designate, will direct Meadow Brook's presentation of the Shaw Festival's *Candida* running Jan. 8 through Feb. 2. *Candida* is a romantic comedy about relations between man and women in families and society.

The Foreigner by Larry Shue opens Feb. 12. The comedy concerns an Englishman in Georgia who pretends to speak no English. *The Foreigner* runs through March 9.

Wait Until Dark, by Frederick Knott opens March 19. The thriller concerns a young bride who is blind and terrorized by

criminals. The play runs through April 13.

Meshuggah Nuns by Dan Goggin is the latest in the series of nun musical comedies and debuts April 23. The Little Sisters of Hoboken take a cruise and fill in for the ill cast of *Fiddler on the Roof*. *Meshuggah Nuns* runs through May 18.

Meadow Brook Theatre unveiled the new Family Series Program for the 2002-2003 season. Participating audiences will see three production selected, scheduled and priced for families. The Family Series program includes *A Thousand Cranes*, on Dec. 28, *A Christmas Carol*, on Dec. 7 and *The Foreigner* on Feb. 22. Series subscriptions for the three shows are priced at \$69 for adults and \$56 for children ages 5-17. All shows are at 2 p.m. on

Saturdays

A Thousand Cranes, by Kathryn Shultz Miller is the true story of a 12-year-old survivor of the bombing of Hiroshima, slowly dying from the effects of radiation sickness. The play is produced especially for student and family audiences and runs Sept. 19 to Oct. 5. Shows for the public are Sept. 28 and Oct. 5.

The annual holiday tradition *A Christmas Carol* by Charles Dickens as adapted by Charles Nolte opens Nov. 29. The story of Scrooge's redemption runs through Dec. 22.

Subscriptions for the 2002-2003 season start at \$89 each and are on sale now. Individual tickets, including *A Christmas Carol*, go on sale Sept. 4 beginning at 10 a.m.

Open Daily 11:00 A.M. DINNERS from 4 P.M.

MONDAY & TUESDAY Buy 1 and Get 1 **1/2 Off**
Dinner Only • After 4 pm (Regular menu only) Some Restrictions Apply

Lunches Starting at \$4.50

THURSDAY All-You-Can-Eat PRIME RIB \$13.95
Includes Soup or Salad • Vegetable • Choice of Potatoes

20300 Farmington Road South of 8 Mile • Livonia 248.474.2420

Rosa's Italian Chophouse

concerts at MEADOW BROOK music festival at oakland university

MAY
24 Harry Connick Jr. & His Big Band
25 The Cranberries

JUNE
1 Monkee Mania starring Micky Dolenz & Davy Jones w/ Barry Williams
15 Dan Fogelberg w/ His Band
19 Anne Murray
22-23 Fine Art at Meadow Brook Juried Art Fair
26 Scholastic's The Magic School Bus Live presents "The Traveling Sound Show" • 1 pm & 7 pm
28-30 Michigan Wine and Food Festival

JULY
3 Jewel
5 Jim Brickman
7 Widespread Panic w/ moe
10 Ambrosia/Gary Wright
16 Garfield in "Happy Birthday To Me" • 1 pm & 7 pm
17 Barrage
18 David Cassidy
25 Dave Koz & Friends featuring Norman Brown & Brian Culbertson with special guest James Ingram

AUGUST
7 Amazing Johnathan
18 Jethro Tull
23 Get Back! The Cast of Beatlemania

SEPTEMBER
1 Carrot Top
6 Spirit of Ireland
7 Bluegrass Festival Featuring Rhonda Vincent

Tickets at Palacelet.com, The Palace Box Office and all **ticketmaster** locations. Charge (248) 645 6666. Discounts on select shows for groups and kids under 12. Call (248) 377 0100. Show day time and prices subject to change.

PROUD SPONSORS: POH Medical Center, BELLE TIRI, HOUR, Standard Federal, ENTERASYS, THE HONEYBAKED HAM, Blue Cross Blue Shield of Michigan.

FREEDOM HILL AMPHITHEATER 2002 SUMMER The Hill is Alive with thousands of Music

Watch for More Great Shows to be Announced!

Freedom Hill Amphitheater Where the Stars come out at night!

June 27 Brian McKnight

June 29 Beach Boys

July 20 Kenny Rogers

August 6 Michael Bolton

June 7 WOMC Super 60's Rock N' Roll (The Turtles, Paul Revere & The Raiders, The Grass Roots)

15-16 1987 Smooth JazzFest

21 Sugar Ray

22 WRIF HarleyFest featuring Cheap Trick

23 Lonestar wsg Carolyn Dawn Johnson & Emerson Drive

27 Brian McKnight

29 Beach Boys

30 Chris Isaak & Natalie Merchant

July 3 INXS/ Simple Minds

9 Cirque Eos 11am & 7pm

12 Teddy Pendergrass & Jeffrey Osborne

16 Heart wsg Eric Burdon

18 Little Bear 11am & 7pm

20 Kenny Rogers

Aug 1 The Rippingtons, Jean Luc-Ponty, & David Benoit

2 Michael Flatley's Lord of the Dance

6 Michael Bolton

8 Frankie Valli & The Four Seasons (Felix Cavaliere & The Rascals, Lou Christie, The Association)

9 1964...Beatles Tribute

14 Franklin the Turtle 11am & 7pm

15 Al Green wsg Ann Nesby

16 Paul Anka

17 Scintas

23 Hank Williams Jr.

These Tickets On Sale Now!
All Tickets On Sale April 26

Tickets starting at \$15
★ Children's Series \$30
(\$15 off the regular ticket price when you buy the series)
All shows and dates are subject to change

Freedom Hill Amphitheater is conveniently located on Metro Parkway (16 Mile Road) just east of Schoenherr in Sterling Heights with easy access from I-75, I-94, I-696 or M-59.

Let's GO!

Your Guide to Suburban Entertainment

LIVE MUSIC

Anne Murray: 8 p.m. Wednesday June 19 Meadowbrook Music Theatre Rochester \$37.50 \$18.50 (248) 645-6666

Blink-182 and Green Day: With Saves the Day 7:30 p.m. Tuesday June 11 Palace of Auburn Hills \$35 (248) 645-6666

Brian Vander Ark: 8 p.m. Thursday April 25 Magic Bag Ferndale \$12 (248) 544-1991

Britney Spears: 7:30 p.m. Monday June 24 Palace of Auburn Hills \$78-\$52.25 (248) 645-6666

The Cranberries: 7:30 p.m. Saturday May 25 Meadowbrook Music Theatre Rochester \$27.50 \$20 (248) 645-6666

Dan Fogelberg: 8 p.m. Saturday June 15 Meadowbrook Music Theatre Rochester \$32.50-\$18.50 (248) 645-6666

Gordon Lightfoot: 8 p.m. Saturday April 27 Michigan Theatre, Ann Arbor \$37.50 \$42.50 (248) 645-6666 or (734) 763-TKTS

Harry Connick Jr. and His Big Band: 8 p.m. Friday May 24 Meadowbrook Music Theatre Rochester \$69.50 \$26 (248) 645-6666

Howie Statland: Of NYC Smoke presents a solo show Tuesday April 30 at Lili's 21 Club 2930 Jacob Hamtramck (313) 875-6555

Jimmy Smith Quartet: 7 p.m. and 10 p.m. Saturday April 27 Magic Bag Ferndale \$30 Must be 21 or older (248) 544-1991

Masquerade: 8 p.m. Friday April 26 Magic Bag Ferndale \$7 Must be 21 or older (248) 544-1991

Monkee Mania starring Mickey Dolez and Davey Jones: With Barry Williams 8 p.m. Saturday June 1 Meadowbrook Music Theatre \$35 \$18.50 (248) 645-6666

Paul McCartney: 8 p.m. Wednesday May 1 Palace of Auburn Hills \$252.50 \$52.50 (248) 645-6666

Sammy Hagar and David Lee Roth: Friday May 31 DTE Energy Music Theatre \$49.50 \$30.50 (248) 645-6666

The Stylistics, the Delfonics and Harold Melvin's Blue Notes: 7:30 p.m. Saturday June 15 DTE Energy Music Theatre \$29-\$16.50 (248) 645-6666

PROFESSIONAL THEATER

Century Theatre: *Late Nite Catechism* through June 23 7:30 p.m. Thursday 8:30 p.m. Friday 5:30 p.m. and 8:30 p.m. Saturday 1:30 p.m. and 5:30 p.m. Sunday Detroit \$24.50 \$37.50 (313) 963-9800

Detroit Repertory: *Fast Ducks* a comedy by Elena Hartwell through May 19 8:30 p.m. Thursday Saturday 3 p.m. Saturday and 2 p.m. and 7:30 p.m. Sunday, at the theater 13103 Woodrow Wilson \$15 (313) 868-1347

Fisher Proof continues through Sunday May 12 \$20-\$47.50 (248) 645-6666 Benefit performance for Kadima Tuesday April 30 Tickets \$75 call (248) 559-8235

Gem Theatre: *Guys on Ice* through April 28 8 p.m. Thursday Friday, 6 p.m. and 9 p.m. Saturday 2 p.m. and 6 p.m. Sunday \$24.50-\$37.50 (313) 963-9800

Jewish Ensemble Theatre: 14th annual New Play Festival includes staged readings of Motti Lerner's (adapted from a story by Isaac Bashevis Singer) *Passing the Love of Women* Monday Tuesday April 29-30 all performances begin at 7:30 p.m. in the Aaron DeRoy Theatre in the lower level of the Jewish Community Center 6600 Maple at Drake West Bloomfield \$5 (248) 788-2900

Meadow Brook Theatre: The classic rock musical *Godspell* opens for previews Thursday April 25 opening night Saturday, April 27 continues to Sunday May 19 previews 8 p.m. Thursday Friday, April 25-26 Curtain 8 p.m. Wednesday Saturday, 2 p.m. and 6 p.m. Wednesday, 6 p.m. Saturday, and 2 p.m. and 6:30 p.m. Sunday, in the theater at Wilson Hall on the Oakland University campus Rochester Hills \$26 \$38, \$17 \$26 (248) 377-3300

Plowshares Theatre Company: *The Diva Daughters Dupree* May 2-6 7:30 p.m. Thursday Friday, 3

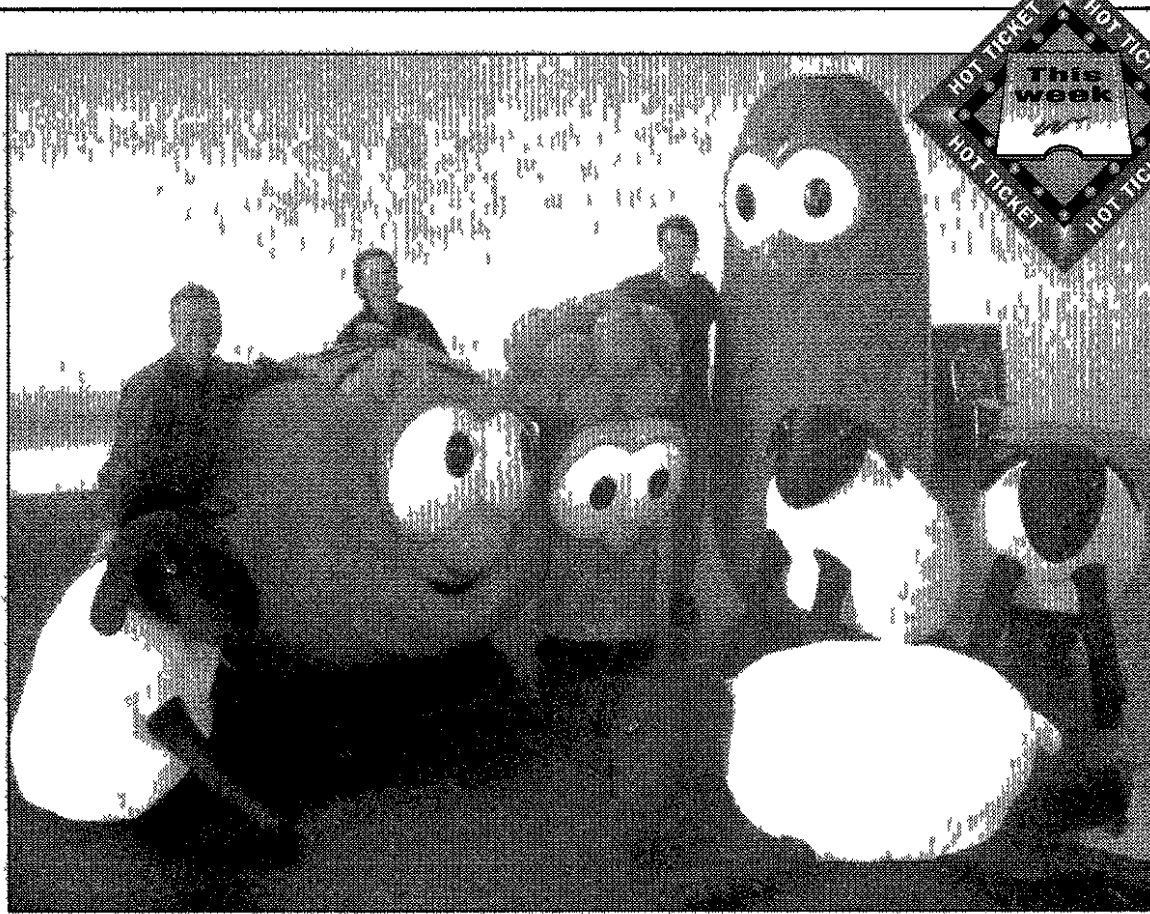

Salad days: *Bob the Tomato, Larry the Cucumber and the rest of the VeggieTales* cast bring their zany antics to the Fox theatre Thursday-Sunday, April 25-28. Tickets are \$13.50-\$27.50. Call (248) 433-1515

p.m. and 8 p.m. Saturday except for 6 p.m. Saturday, May 4 3 p.m. and 8 p.m. Sunday May 5 and 6 p.m. May 12 19 and 26 at the General Motors Theater in the Charles H. Wright Museum of African American History, Detroit \$20 advance \$25 at door matinee \$15 advance \$20 at door, and seniors/students \$15 advance \$20 at door \$10 pre views May 2, 3, 2 for 1 Thursday \$20 for 2 in advance \$25 for 2 at door Group rates available (313) 872-0279

Purple Rose Theater: *Born Yesterday* Garson Kanin's American comedy continues to June 15 8 p.m. Wednesday Saturday 3 p.m. Saturday and 2 p.m. Sunday at the theater 137 Park Street Chelsea \$22.50 \$32.50 (734) 433-7673

COMMUNITY THEATER

Avon Players: *Joseph and the Amazing Technicolor Dreamcoat* April 26-28 May 3-5, 10-12 and 16-18 8 p.m. Thursday Saturday, 2 p.m. Sunday at the Avon Playhouse 1185 Washington Road off Tienken Rochester Hills \$15 \$13 students/seniors and Thursdays and Sundays (248) 608-9077

Players Guild of Dearborn: *Damn Yankees* opens 8 p.m. Friday April 26 curtain 8 p.m. Friday Saturday through May 18 2:30 p.m. Sunday, May 5 12 and 19 Bring mom to the show for free on Mother's Day 21730 Madison southeast of Monroe and Outer Drive, Dearborn Tickets \$14 reserved (313) 561-TKTS

DINNER THEATER

Genitti's: *Wild, Wild Western Michigan* Genitti's own Spaghetti Western continues Friday Saturday April 26-27 and Tuesday April 30 at Genitti's Hole-in-the-Wall 108 East Main Northville \$45 includes dinner (248) 349-0522

Vladimirs: *Oh Idaho*, murder mystery presented by Death Row Players 7 p.m. Friday May 17 28125 Grand River, north of Eight Mile Farmington Hills Tickets \$35 per person in advance include show, meal and one drink ticket (248) 399-1101

YOUTH PRODUCTIONS

Genitti's Children's Lunch Theater: *Shirley Holmes Girl Detective*, a mystery at the science fair 11:30 a.m. Friday Saturday April 19-20 and Sunday April 28 at Genitti's Hole-in-the-Wall, 108 East Main, Northville \$12.95, \$11.95 children includes lunch (248) 349-0522

Marquis Theatre: *Jack and the Beanstalk* continues through Sunday April 21 Shows 2:30 p.m. 1:35 E. Main St. Northville, \$7.50, *Hansel and Gretel* opens 7 p.m. Friday, May 10 curtain 2:30 p.m. Saturday, May 11 18 and 25, 2:30 p.m. Sunday May 19 (248) 349-8110

Thomas the Tank Engine: Pulls into Greenfield Village Saturday Sunday April 27-28 (313) 271-1620 or www.hfmgv.org

St. Dunstan's Theatre Guild. Brings art fairy tales and puppets to Cranbrook Art Museum 2-4 p.m. Saturday May 4 Children can meet and mingle with their favorite fairy tale characters and have a chance to invent their own endings to popular tales Puppet show begins 3:30 p.m. Reservations recommended call (248) 645-3361

PuppetArt: Presents marionette ballet version of *Cinderella* 2 p.m. Saturday April 27 Kolobok a Russian version of the Gingerbread Man plays 2 p.m. Saturday, May 4 11, 18 and 25 at the theater 25 E. Grand River Detroit, (313) 961-7777

Novi Theatres: *The Lion the Witch & the Wardrobe* 7:30 p.m. Friday Sunday May 17 19 Novi Civic Center 45175 W. 10 Mile Road Novi \$8 in advance \$10 at the door (248) 347-0400

SPECIAL EVENTS

Andover Young Actors: *You Can't Take it with You* 7:30 p.m. Friday Saturday April 26-27 and 2:30 p.m. Sunday April 28 in the Andover theater one block west of Telegraph one block south of Long Lake \$8 \$5 students and seniors (248) 645-4679

Birmingham Community House. Graduate Gala Concert featuring Erin Chupinsky Pranidi Varshney and Ashwini Hardkar 6 p.m. Sunday, April 28 380 Bates Birmingham \$10 advance, \$15 at door (248) 644-5832

Birmingham Concert Band: Joins

forces with Jack Gogin former WXRZ radio host to present a live rendition of his *Film Classics* show 3 p.m. Sunday April 28 Groves High School Auditorium 20500 West 13 Mile

CAPA Senior Gallery: The Creative and performing Arts Program of Livonia Public Schools presents a program of music and dance 7 p.m. Friday April 26 at Churchill High School Auditorium 8900 Newburgh north of Joy Informal show music opens the event at 6:30 p.m. No charge Call (734) 523-8841

Great Lakes International Banjo Convention: Noon to midnight Thursday Saturday April 25-27 Concerts 7 p.m. Friday Saturday Holiday Inn Fairlane 5801 Southfield Service Dr. at Ford Road Dearborn Friday Saturday concert admission \$5 Free concert 2 p.m. Saturday (734) 282-6635

Jewish Film Festival: Sunday April 28 to Wednesday May 8 Where United Artists Theatres 14 Mile at Haggerty Commerce Township Birmingham 8 Theatre on Old Woodward Avenue south of Maple Birmingham and the Michigan Theatre 603 E. Liberty Ann Arbor \$8 \$7 seniors festival pass for all movies \$89 \$79 seniors (248) 788-2900

Meet Your Best Friend at the Zoo: The 10th annual event takes place 10 a.m. to 5 p.m. Saturday Sunday May 4-5 the Michigan Humane Society and 26 other animal welfare organizations will be at the zoo to find loving homes for



Chamber music: Pianist Leon Fleisher (pictured), hornist David Jolley and violinist Michael Tree perform on the Chamber Music Society of Detroit series 8 p.m. Saturday, April 27, at the Seligman Performing Arts Center at Detroit Country day School, 13 Mile and Lahser, Beverly Hills Tickets are \$18-\$67, \$15 students Call (248) 855-6070

hundreds of animals at the Detroit Zoo 8450 West 10 Mile Royal Oak (248) 398-0900

Michigan Fingerstyle Guitar Society Presents a concert 8 p.m. Saturday April 27 and workshop with Alex de Grassi Sunday April 28 at the Village Players Club 24660 Woodward Birmingham \$15 \$10 students for concert Workshop \$50 for three hours of instruction (248) 433-3429

Midwest Regional Fleadh Cheoil: Irish music and dance competition 9 a.m. to 5 p.m. (music) and 7 p.m. (group competitions) Saturday April 27 \$5 for either daytime or evening competitions or \$9 both Irish music concert 8:30 p.m. Friday April 26 at the Doubletree Hotel 31500 Wick Road Romulus (734) 420-0962 or (519) 948-9149

Sweet Charity: Presented by North Farmington High School 7:30 p.m. Thursday Saturday April 25-27 \$10 \$8 students and seniors (248) 426-4740

Redford Theatre Motor City Organ Society presents organ overture 7:30 p.m. 8 p.m. screening of *Funny Girl* starring Barbra Streisand 17360 Lahser at Grand River Detroit \$3

School Auditorium 8900 Newburgh north of Joy Livonia Tickets \$16 \$10 students age 13 and over children free Call (734) 425-4855 or (248) 645-6666

Metropolitan Chamber Orchestra: Under the direction of Joseph Striplin perform a concert *Perpetuating the Legacy* featuring Richard Helderop on the historic Kimball pipe organ 5 p.m. Saturday April 27 at Second Baptist Church 441 Monroe Detroit (313) 872-0252

Redford Civic Symphony: Spring concert 3 p.m. Sunday May 5, Thurston High School Redford www.redfordsymphony.com

CHORAL

Livonia Youth Choir: Perform 7 p.m. Saturday, April 27, at Faith Lutheran Church, 30000 Five Mile, west of Middlebelt, Livonia Admission is free (734) 425-1749

Plymouth Community Chorus: Sing annual spring concert 8 p.m. Saturday April 27 4 p.m. Sunday April 28 Northville High School 45700 Seven Mile, Northville Tickets \$10, available at Sideways 505 Forest Ave., Plymouth Evola Music, 7170 N. Haggerty Gardenwicks, 202 W. Main Northville (734) 455-4080

Plymouth Oratorio Society: Anton Bruckner's Mass in D minor two works by John Rutter 8 p.m. Saturday April 27 Ward Presbyterian Church 40000 Six Mile Northville Township Freewill offering \$5 suggested (734) 455-8353

Schoolcraft College Community Chorus: Spring concert features music of love peace and hope by Gastoldi Bizet Bernstein and Ernst Toch 8 p.m. Saturday April 27 also on the program is Innisfree choir conductor Gerald Custer's choral setting of a poem by W.B. Yeats at St. Matthew's United Methodist Church, 30900 Six Mile between Merriman and Middlebelt Livonia Donations will be accepted during intermission (248) 349-8175 or (734) 462-4435

Madison Chorale: 8 p.m. Saturday April 27 at Big Beaver Methodist Church 3733 John R. Troy and 8 p.m. Saturday May 4, at St. Margaret of Scotland Catholic Church 21201 13 Mile, St. Clair Shores Both concerts feature a celebration of the 100th anniversary of the birth of Richard Rodgers \$12 donation at the door \$10 advance \$8 ages 18 and under (248) 585-4871

Vocal competition: Ten finalists in the Verdi Opera Theatre of Michigan vocal competition for high school students will perform Italian songs and arias during a concert 4 p.m. Sunday, May 5 at the Italian American Cultural and Community Center in Warren Finalists include Victoria Lauzun a student at Clarkston High School, Katherine Riopelle a student at Cranbrook Kingswood, and Adam Smith a student at Southfield High Tickets \$7, \$5 seniors/students at the door (734) 455-8895 (810) 751-2855

Farmington Community Chorus: Made in America spring concert, 8 p.m. Friday Saturday, May 10-11 Seligman Performing Arts Center 22305 W. 13 Mile, corner of Lahser, Beverly Hills Tickets \$10 at the door available in advance by calling (810) 632-4067 or online www.farmingtonchorus.com For chorus information call Kathy Hall (248) 471-4516

Troy Community Chorus: *Going Places* 7 p.m. Saturday May 11, Troy Athens High School John R. north of Wattles \$8 in advance, \$5 seniors 60 and older, and children age 12 and younger, \$10 at the door (248) 879-0138

Oakland University Community Chorus: *Elijah*, an oratorio by Felix Mendelssohn 8 p.m. Friday April 26 at St. John Lutheran Church on University Rochester \$10 \$8 seniors \$5 students (248) 370-3013

AUDITIONS/ OPPORTUNITIES

Birmingham Musicals: Holds auditions for the Charles E. Shontz Strings Award 10 a.m. Saturday May 18 at First Baptist Church, Willets Street at Bates one block west of Old Woodward Applicant must be high school graduates between the ages of 18 and 22 residents of Michigan and perform on violin viola cello or string

Please see next page

BENEFITS

Benefit luncheon: The Meadow Brook Theatre Guild hosts Luncheon on the Aisle on Friday April 26 at the Meadow Brook Theatre at Oakland University Rochester to benefit the theater Box lunch event features behind the scenes secrets of professional theater a bake sale plant sale and *Godspell* rehearsal (248) 375-9840

Greenfield Village Antiques Show & Sale: Preview evening 6:10 p.m. Friday May 17 at Lovett Hall in Henry Ford Museum & Greenfield Village Dearborn \$100-\$350 (313) 982-6120

Polar Blast: The Detroit Zoological Society's annual *Sunset at the Zoo* fundraiser features a strolling supper from many of the area's finest restaurants and raffle 7:11 p.m. Friday June 21 at the zoo 8450 West 10 Mile Royal Oak \$75 \$500 per person raffle tickets \$100 Proceeds will support education and conservation programs for the Arctic Ring of Life the zoo's polar bear exhibit (248) 541-5717

Tom Chapin: And Ralph Welton give a benefit concert 7 p.m. Friday April 26 at Genitti's Hole-in-the-Wall 108 East Main Northville \$65 includes Genitti's 7 course meal Proceeds to benefit the Avon Breast Cancer Crusade Seating limited (248) 349-0522

OPERA

Michigan Opera Theatre: Presents Verdi's masterpiece *Otello* adapted from Shakespeare's tragedy *Othello* through Sunday April 28 at the Detroit Opera House 1526 Broadway (313) 237-SING or online at www.MichiganOpera.org

CLASSICAL

Detroit Chamber Winds & Strings: Springtime Souvenirs featuring Tchaikovsky's *Souvenir de Florence* the popular string sextet which inspired the program 4 p.m. Sunday April 28 at Birmingham Unitarian Church 38651 Woodward north of Lone Pine Road Bloomfield Hills and 3 p.m. Sunday May 5 at Christ Church Grosse Pointe 61 Grosse Pointe Blvd Grosse Pointe Farms \$22 \$18 students and seniors over age 60 \$10 children age 12 and under (248) 559-2095

Detroit Symphony Orchestra: Mahler's *Song of the Earth* 8 p.m. Thursday Friday May 2-3 and 8:30 p.m. Saturday May 4 6:30 p.m. Friday May 3 preconcert event Mahler's Arrangement of Beethoven Scores Orchestra Halal Detroit \$20-\$54 (313) 576-5111 Seniors and students can purchase 50 percent off rush tickets at box office one hour prior to classical concerts based on availability

Detroit Symphony Civic Orchestra: Works by Bernstein and Strauss featuring guest conductor Marcus Belgrave 3 p.m. Sunday May 5 Orchestra Hall \$10 box seats \$15 (313) 576-5111

Livonia Symphony Orchestra Spotlights 15 year old pianist Sanjay Mody in Frederic Chopin's *Concerto No. 1 in E Minor for Piano & Orchestra* 7:30 p.m. Saturday April 27 Churchill High

Let's GO!

Your Guide to Suburban Entertainment

Making contact: Please submit items for publication in Let's Go to Linda Chomin, two weeks in advance of event Observer & Eccentric Newspapers, 36251 Schoolcraft, Livonia, MI 48150 or fax (734) 591 7279

Continued from previous page

bass Deadline for application is May 11 (248) 375 9534

Franklin Village Band: Adult musicians from southeastern Michigan are invited to join the Franklin Village Band All instruments welcome but there is a special need for flutes and clarinets The band rehearses Monday evenings in the Franklin Community Church social hall on Franklin Road between 13 and 14 Mile roads For more details call Bill Prisk (248) 474-8869 or Bob Zimmerman (313) 535-4119

Henry Ford Community College: Auditions for Story Theatre 7 10 p m Tuesday Wednesday June 4-5 Mackenzie Fine Arts Center on campus 5101 Evergree Dearborn Second City style scripted show consist of improvisations and readings from script Performances Aug 15 25 course registration required (313) 845 9817

Livonia Youth Choir: Is now looking for new members as well as a music director Interested persons for the director position should have a degree in music performance or music education, and a demonstrated interest and love of working with young people Auditions for choir members will be held in September for girls and boys (with unchanged voices) who will be in grades 4-8 in the new school year For more information, call (734) 425-1749

Oakland Youth Orchestra: Auditions for 2002 2003 season Sunday May 12 Wednesday May 15 Friday Saturday May 17 18 To register online www.oyom.org or call (248) 652 2526 Group consists of three separate performing groups for musicians in grades 3-12

Plymouth Theatre Guild/Spotlight Players: Accepting applications for book directors music coordinators choreographers music conductors audition accompanists rehearsal accompanists musicians for the 2002 2003 season presentations of *Cinderella A Funny Thing Happened on the Way to the Forum* and *Dial M for Murder* Applications close Friday May 31 call (248) 349 7110

Ridgedale Players: Junior Actors of Ridgedale is holding auditions for *The Beverly Hillsbillies* 1 p m Saturday April 27 young people ages 13-18 are invited to audition for production which runs June 21-23 at the Ridgedale Playhouse 205 West Long Lake between Livernois and Crooks Troy (248) 584-2345

Stagecrafters: Auditions for Youth Theatre production of *Peter Pan* 8 30-10 a m Saturday April 27 Baldwin Theatre 415 S Lafayette Royal Oak Show opens July 19 (248) 541 8027

POPS/SWING/ CABARET

Bird of Paradise Orchestra: 9 p m Monday at the Bird of Paradise Ann Arbor (734) 662 8310 (big band swing, bop)

Birmingham Community Band: Film Classics Live featuring Jack Gogin former WQRS radio host 3 p m Sunday April 28 Groves High School auditorium 20500 W 13 Mile

Rockapella: Known for the Folger's Coffee commercial and *Where in the World is Carmen San Diego* will perform 7 30 p m Saturday May 4 at North Farmington High School 32900 W 13 Mile Road Farmington Hills \$15 adults \$10 students & seniors (248) 426-4740

JAZZ/BLUES

Christa Grix: Jazz harpist 7 30 p m Friday April 26 Borders Books 30995 Orchard Lake Road Farmington

Ron Brooks Trio: 9 p m Tuesday and Thursday Bird of Paradise Ann Arbor \$5 cover (734) 662 8310

Los Gatos: 9 p m Wednesday Bird of Paradise Ann Arbor \$5 cover (734) 662 8310

Paul Keller Orchestra: Featuring clarinetist Jim Wyse and vocalist Susan Chastain 3 p m Sunday April 28 at Temple Beth El Synagogue 14 Mile at Telegraph Bloomfield Hills \$15 (248) 476-2674

Matt Michaels Trio: With guests 8 11 30 p m Wednesday at

Ron's Fireside Inn 28937 Warren Road two blocks east of Middlebelt \$5 cover with dinner order \$10 without (734) 762 7756

Larry Nozero Jazz Quintet: Performs 8 p m to midnight Monday at Mitch Housey's Food & Spirits Livonia (734) 425 5520 or visit www.larrynozero.com

Schoolcraft College Jazz Band: Playing the music of Stan Kenton Buddy Rich Woody Herman and featuring Cindy Pierson on vocals 7 30 p m Monday April 29 also featured is the new Jazz Lab/Improvisation Group 18600 Haggerty between Six and Seven Mile roads Livonia No charge

Tony Pope's N'Orleans Six: 3-6 p m Saturday May 4 and every other weekend through June 1 at Tom's Oyster Bar Southfield \$6 (248) 476 2674

Tim Flaherty Trio: With Nancy K perform 9 p m Saturday April 27 Woodruff's Supper Club Sixth east of Washington Royal Oak (248) 543-5070

FOLK/ACOUSTIC

Larry Arbour: Acoustic folk rock 7 10 p m Thursday Friday Flying Fish Tavern Beverly Hills (248) 647 7747

Alex de Grassi: At the Village Players Club of Birmingham 34660 Woodward Ave Doors open 7 p m show 8 p m Saturday April 27 \$15 \$10 students (248) 433 3429 Workshop for a small group of guitarists Sunday April 28 Limited to 15 students cost \$50 for three hours of instruction visit www.MichiganFGS.org to register

Burt Holiday & the Gaylords: 2 p m Saturday May 4 at the Farmington Civic Theatre 33332 Grand River at Farmington Road and 9 p m Saturday May 4 South Lyon Theatre corner of 10 Mile and Main \$20 (248) 473-7777

WORLD MUSIC

Pat McDunn: 8 11 p m Friday at Duke Humphries Rochester Hills No cover (248) 601 1100 (Irish)

Pipe Bands in Concert: The Pipers & Band Society of Ontario Windsor/Detroit branch present its annual Two Band Night featuring the Toronto Police Pipe Band and the Windsor Pipe Band 7 p m Saturday April 27 both bands will be competing in the World's Pipe Band Championship in Scotland in August also on the April 27 program is Celtic music by Colin Paige and Len Wallace as well as Highland Dancers performing at the Monaghan K of C Hall 19801 Farmington Road Livonia \$15 at the door Scottish fare available (248) 477 7542

The Diggers: 8 30 p m Thursday April 25 at Sean O Callaghan's Irish Pub 821 Penniman Plymouth Live Irish music Tuesday Thursday and Sunday (734) 459 6666

CLASSIC/ MODERN DANCE



Award-winning duo: Nicholas Ashford and Valerie Simpson bring their Motown hits to Music Hall Center for the Performing Arts 8 p.m. Saturday, April 27 Tickets are \$25-\$40 Call (313) 963-2366 Since beginning their music career in 1964, the duo have won more than 50 ASCAP awards

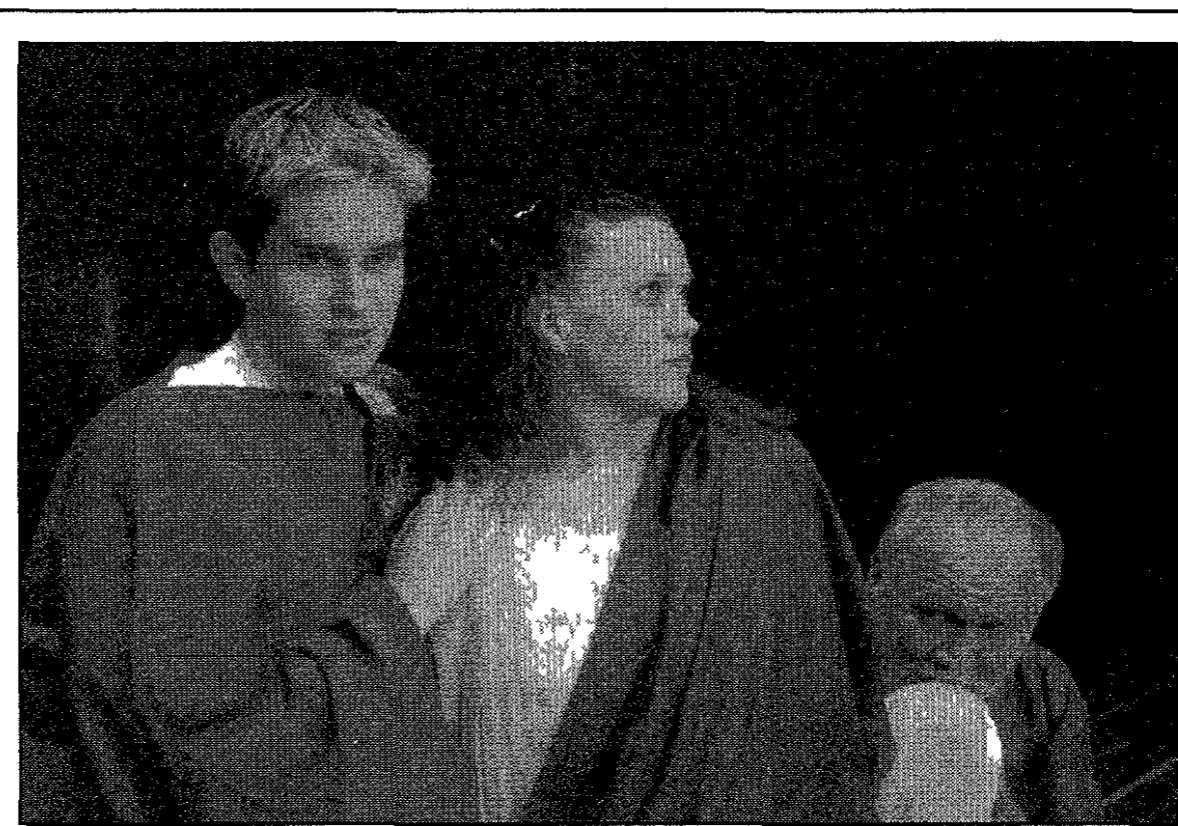

Stephen Sondheim music: Mark McCleese (left), Lori Gardley and Steve Kryda are three of the actors in the comedy musical "A Funny Thing Happened on the Way to the Forum" 8 p.m. Friday-Saturday, April 26-27 and May 3-4, at Mason Middle School, 3835 West Walton, between Clintonville and Sashabaw roads, Waterford Tickets are \$9, \$8 students and seniors (248) 673-9799

Detroit Dance Collective: Present its 22nd annual spring dance concert featuring new pieces including *Carnival of the Animals* set to the music of Camille Saint Saens 8 p m Friday April 26 Ford Community & Performing Arts Center 15801 Michigan Avenue at Greenfield Dearborn \$18 \$12 seniors/students (313) 943 2354

Michigan Classic Ballet: *Seasons of Spring* dance concert 2 p m Sunday April 28 at the Geiger Classic Ballet Academy 782 Denison Court Bloomfield Hills \$5 (248) 334-6964

SOCIAL DANCING

Blackberry Creek Dancers: Country western dance 7 p m Friday April 26 at the Italian Cultural Center Warren \$10 (810) 202 7558

Moon Dusters: Ballroom dancing to live bands featuring swing fox trot waltz cha-cha and Latin 8 30-11 30 p m Saturday at the Livonia Civic Center 15218 Farmington Road at Five Mile Road \$5 (248) 967 1428

Rhythm 'N' Shoes: Weekly ballroom/Latin dance party with DJ 8 30-10 30 p m Thursday 2172 Franklin Road Bloomfield Hills \$7 (248) 334-0299

U-M Ballroom Dance Club: Ballroom dance lessons and open dancing 4 10 p m Sunday at the Union Ballroom Ann Arbor \$2 (734) 763-6984

POETRY/ SPOKEN WORD

Poetry Lounge: Join the Open Mic poetry series at Affirmations Lesbian and Gay Community Center 195 W Nine Mile Road Ferndale Bring original and/or

published poems to read or just come to listen Poetry Lounge every third Wednesday through April in the Pittman Puckett Art Gallery at the community center (248) 398-7105

COMEDY

Second City: New female revue Chickalicious joins Two for Tuesdays — Show and Osamalama Ding Dong at 8 p m Chickalicious featuring Lisa Maxine Melinn of West Bloomfield Ashley Ann Back of Bloomfield Hills and Cara Lee Burk of Rochester Hills runs 8 p m Tuesday through May 14 Touring company presents *The Best of Second City* 8 p m Wednesday Jihad It Up to Here shows 8 and 10 30 p m Thursday Friday 8 p m Sunday Ticket prices and show times vary \$5 \$20 (313) 965 2222

Ann Arbor Comedy Showcase: Tim O'Rourke 8 p m Thursday Saturday April 25 27 additional shows 10 30 p m Friday Saturday 314 E Liberty (734) 996 9080

CALL FOR ARTISTS

Art Dash: Looking for artists to donate work for a fund raising event for Arbor Hospice Thursday May 30 at St John's Golf and Conference Center Plymouth (248) 348-4980

Art on the Green: The Franklin Arts Council is seeking artists in a variety of media for the 22nd annual Labor Day Fine Arts Show *Art on the Green* in Franklin Village 10 a m to 5 p m Monday Sept 2 For an application call (248) 594-3093

ArtServe Michigan: Applications are now available for the 2003 Creative Artist Grant program including creative writing music film video and inter/multidisciplinary categories Deadline for entry is Friday, May 17 Application can be downloaded from the library at www.ArtServeMichigan.org Questions call Christine Scheffman at (248) 557 8288

Detroit Festival of the Arts: Looking for artists for its annual festival Sept 13-15 in the University Cultural Center Deadline for entry is April 26 (313) 577 5088

Detroit Zoo: Looking for artists to create works of art on 6 foot polar bear fiberglass forms for Polar Palooza an Arctic celebration to take place this summer If interested call Lisa Wisniewski at ArtServe Michigan (248) 557 8288 Ext 12 The zoo is also looking for sponsors for the 100 fiberglass polar bears to be exhibited in Royal Oak For more information call (248) 398-0900 or visit the Web site at www.detroitzoo.org

Livonia Arts Commission: Is looking for artists and crafters for its 26th annual Arts Festival Saturday Sunday, June 8 9, in Greenmead Historical Park in Livonia For an application, call the community resources department at (734) 466 2540 Exhibitors are also wanted for the display

cases in the Livonia Civic Center Library Artists or collectors should contact Donna Eno at (734) 261-5870

VSA arts of Michigan: Looking for professional artists who are interested in sharing their creative processes in dance drama literature music poetry and the visual arts with students with disabilities Artists must be interested in learning how to accommodate students with a variety of disabilities Qualified artists will be trained at the R A MacMullan Conference Center at Higgins Lake in Roscommon Saturday Tuesday June 15 18 Following training VSA arts of Michigan will provide work for artists in artist in residence programs in K-12 schools throughout the state Interested artists should send resumes to Artist in Residence Initiative VSA arts of Michigan 51 West Hancock Detroit MI 48201 For more information call (313) 832 3303 or send e mail to vsami@ic.net

ART CLASSES/ WORKSHOPS

Ann Arbor Art Center: Adult and youth courses including ceramics jewelry making figure sculpting and drawing Renaissance painting tilemaking mosaics glass blowing pottery puppetry wheel throw clay and more 117 W Liberty Ann Arbor (734) 994-8004 Ext 101

Art Gallery/Studio: Margaret Cooney and Kay Rowe teach watercolor classes in April Carol Knotts teaches pastel in Sheridan Square Shopping Center Garden City (734) 261 0379

Art of Living Studio: Drawing scarf dyeing and awakening your artistic vision classes book conversation and poetry nights 11 Broadway Lake Orion (248) 693 3632

Birmingham Bloomfield Art Center: Art classes from preschool through adult 1516 South Cranbrook Road Birmingham (248) 644-0866

Creative Arts Center: Classes for children teens and adults in art music drama and dance 47 Williams Street Pontiac (248) 333 7849 Scholarships available for students with financial need

D & M Studios: Taking registration for summer art camps This year's theme — Going Buggy For more information call (734) 453 3710

Plymouth Community Arts Council: Spring classes continue in multi media art drawing painting pottery digital imaging and beading Summer visual arts camps are also open for registration (734) 416-4278

Spring art classes: With Staci Miron in her Novi studio watercolor or acrylic and beginning printmaking (creating stamps) for kids and adults (248) 668 1718

Touch of Light: The Studio and Gallere of Handblown Glass offers classes in glass blowing Classes meet Wednesday Friday evenings and Saturday Sunday afternoons 23426 Woodward Ave Ferndale (248) 543 1868

Visual Art Association of Livonia: Classes in various arts forms including oil watercolor pastel and drawing at the Jefferson

Center Room 16 9501 Henry Ruff Livonia Mary Ann Adams (734) 455 9517

ART LECTURES/ MEETINGS

Northville Arts Commission: Michael Farrell discusses the life and works of Gertrude Stein an American abstract writer (1874-1946) 7 30 p m Thursday April 25 at Hillside Middle School Northville \$10 \$5 students (248) 449-9950

ARTS FESTIVALS

Ann Arbor National Spring Art Show: 10 a m to 6 p m Saturday April 27 and 10 a m to 5 p m Sunday April 28 \$5 University of Michigan Indoor Track Building (330) 896 9498

Farmington Festival of the Arts: Live performances displays hands on activities opens Saturday April 27 with Starry Night Gala 6 30-11 p m and continues to Sunday May 5 (3 p m Community Band concert) (248) 473-1800

Judaic Art & Jewelry Fair: 10 30 a m to 7 p m Sunday April 28 at the Bais Chabad Torah Center 5595 West Maple east of Orchard Lake Road West Bloomfield \$5 (248) 932 3311

Westacres Art Show: 10 a m to 5 p m Saturday April 27 more than 50 artists exhibit a variety of media live entertainment children's art activities and a silent auction to benefit the Child Abuse & Neglect Council of Oakland County Westacres Clubhouse 3700 Westacres Drive south of Commerce Road between Green Lake and Union Lake roads \$1 (248) 360-4551 or (248) 363-6548

GALLERY EXHIBITS (OPENING)

Au Courant Design Studio and Gallery: Michigan artist Lois Teicher will be featured in *Small Scale* April 27 to June 1 opening reception 5 7 p m Saturday April 27 23255 Woodward Ferndale (248) 548 3770

Cary Gallery: *Virtues Values Other Good Things* an exhibition by Susan Kell opens with a reception 6-8 p m Saturday May 4 and continues to June 1 226 Walnut Boulevard Rochester (248) 651 3656

Janice Charach Epstein Gallery: *Assignment Rescue The Story of Varian Fry and the Emergency Rescue Committee* a documentary exhibit organized by the U S Holocaust Memorial Museum in Washington D C opens May 2 and continues to June 27 in the second level gallery Fry has been called the artist's Schindler

Celebrate: an exhibit of Michigan Jewish artists Jewish Community Center 6600 Maple at Drake West Bloomfield (248) 432 5448

Coffee Studio: Landscapes by Nancy Owen open with a reception 7 10 p m Saturday May 4, at the shop 600 Ann Arbor Trail Plymouth

Garden City Fine Arts Association: Spring exhibit and sale of a variety of media including painting drawing and sculpture Monday Saturday May 6 11 opens with a reception and awards presentation 7 p m Monday May 6 at the Garden City Library 2012 Middlebelt, south of Ford (734) 513-4044

Arnold Klein Gallery: Alphabet show opens with a reception 6 8 p m Friday May 3 continues to June 8 32782 Woodward Royal Oak (248) 447 7709

Lemberg Gallery: New Paintings and Works on Paper by Stephen Magsig April 27 June 1 opens with a reception 5 7 p m Saturday April 27 23241 Woodward Ferndale (248) 591 6623

Paint Creek Center for the Arts: Local and national artists exhibit in *Painting as an Abstraction* April 26 to May 24 in Main Gallery *Woven Stillness New Works in Tapestry* in first floor gallery opens with a reception 6-8 p m Friday April 26 407 Pine Street Rochester (248) 651 4110

Revolution Gallery: Recent sculpture by Jim Shrosbee *esgelling*, and Gina Ferrari *Beyond Landscape* opens with a reception 5 7 p m Saturday April 27 continues to June 1 23257 Woodward Ferndale (248) 541 3444

COMING ATTRACTIONS

Scheduled to open Friday April 26

JASON X
In the year 2455 long after humanity has abandoned Earth as a lifeless planet, an expedition of archaeological students discovers a research facility where two people are cryogenically frozen. One a young woman the other a large male in a strange mask. The ice begins to thaw, and so the students bring the bodies back to their spaceship having no idea what they just unleashed on the future and of course on themselves. Jason (New Line) Rated R

LIFE OR SOMETHING LIKE IT

The film revolves around Lanie Kerrigan (Angelina Jolie) a feature reporter at a Seattle television station, who seems to have it all. A baseball superstar boyfriend, a gorgeous apartment and a shot at a big network assignment. In the midst of a fluff piece/interview a homeless local street "seer" named Prophet Jack tells Lanie that she leads a meaningless existence and will die the following week. When Prophet Jack's other predictions come true, Lanie begins to re-examine her life and priorities which

includes rekindling a relationship with a cameraman (Edward Burns) with whom she has long been at odds. Stephen Herek directs the drama. Other featured players include Tony Shalhoub, Christian Kane and Stockard Channing. (Twentieth Century Fox) Rated PG 13

BIG BAD LOVE

This drama weaves together the stories of an alcoholic Vietnam vet, Leon Barlow struggling to become a working writer and that of his ex-wife, Marilyn, who refuses to allow him to see their pre-adolescent son. Alan and daughter Alisha who has an incurable illness. Stars Arliss Howard, Debra Winger, Olivia Kersy and Angie Dickinson. Directed by Arliss Howard. (IFC Films) Rated R

Scheduled to open Friday, May 3

HOLLYWOOD ENDING

Mum's the word on the plot except the fact that Woody Allen plays a Hollywood director who is hired to direct his ex-wife (Tea Leoni) in a movie. Featured players include filmmaker Mark Rydell as Allen's agent, and Treat Williams as Leon's new boyfriend. The studio boss Lending femme support are Debra Messing

(from TV's Will and Grace) and Tiffani Amber Theissen. Allen directs the comedy, marking his first feature since completing *Curse of the Jade Scorpion* in 2001. (DreamWorks) Rated PG-13

THE TRIUMPH OF LOVE

Leonide (Mira Sorvino) Princess of Spar-ta resorts to deception and disguise to win the man she loves, a young prince whose throne she along the way helps restore. The only problem is that her various disguises both male and female end up thrice engaged. (Paramount Classics) Rated PG 13

SPIDER-MAN

Orphaned at an early age, Peter Parker (Tobey Maguire) lived in Queens, New York with his beloved Aunt May and Uncle Ben. Peter led the life of a normal student working as a photographer at the Daily Bugle under the tutelage of publisher J. Jonah Jameson. Pining after the beautiful Mary Jane Watson and hanging out with buddy Harry Osborn. On a school trip during which Peter and his classmates are given a science demonstration on spiders. Peter is bitten by a genetically altered spider. Soon after he discov-

ers that he has unusual powers. He is endowed with the strength and agility of a spider along with a keen ESP like spider sense. Featured players include Kirstin (Get over it) Dunst as Mary Jane Watson, James Franco (TV's Freaky and Geeks) and veteran actor Cliff Robertson as Peter's Uncle. (Columbia Pictures) Rated PG-13

DEUCES WILD

Set in the summer of 1958, the story tells of a Brooklyn street gang, the Deuces, as they learn that loyalty and midnight rumbles can no longer protect them from the turbulent times ahead. Gunfights and honor quickly become a thing of the past as a new breed of wiseguys threaten to take control of their neighborhood. Featured among the ensemble are Fairuza Balk, Matt Dillon, Stephen Dorff, Balthazar Getty, and Brad Renfro. Scott Kalvert directs the drama. (MGM/UA) Rated R

Scheduled to open Friday May 10

THE NEW GUY

After sealing his uncool reputation with an embarrassing ninth grade accident, a high school student decides to switch alma maters his senior year for a final

stab at popularity. All goes well until his primary nemesis follows him to the new school. Featured players include DJ Qualls as the uncool student who reinvents himself as a tough guy, Lyle Lovett, Eddie Griffin and Eliza Dushku. Edward Decker helms the comedy, marking his feature directorial debut. (Columbia Pictures / Revolution Studios) Rated PG 13

UNFAITHFUL

A middle-aged wife and mother has an unexpected and torrid affair with a handsome younger man. After her husband discovers her deceit, he murders his wife's lover and the husband and wife must face the consequences of their actions. Based on the 1969 film *La Femme Infidèle*, the film stars Richard Gere, Diane Lane, Olivier Martinez, and Enk Per Sullivan. Adrian Lyne directs the drama, marking his first since completing *LOLITA* in 1997. (Twentieth Century Fox) Rated R

ESPN'S ULTIMATE X

This large format documentary revolves around the X Games contest shown on ESPN and ABC, and highlights the athletes competing on screens towering six stories high and eight stories wide.

(Buena Vista) Rated PG

Scheduled to open Wednesday May 16

STAR WARS:

EPISODE II - ATTACK OF THE CLONES
Ten years after the events of the Phantom Menace, not only has the galaxy undergone significant change, but so have Obi Wan Kenobi (Ewan McGregor), Padme Amidala and Anakin Skywalker as they are thrown together again for the first time since the Trade Federation invasion of Naboo. Anakin has grown into the accomplished Jedi apprentice of Obi Wan, who himself has transitioned from student to teacher. The two Jedi are assigned to protect Padme, whose life is threatened by a faction of political separatists. As relationships form and powerful forces collide, these heroes face choices that will impact not only their own fates, but the destiny of the Republic. Featured in the cast are Natalie Portman as Padme, Jimmy Smits, Samuel L. Jackson, Frank Oz, Ian McDiarmid, Pernilla August, Christopher Lee, and Hayden Christensen as Anakin. Directed by George Lucas. (Twentieth Century Fox) This film is not yet rated.

OBSERVER & ECCENTRIC
GUIDE TO THE MOVIES

<p>National Amusements Showcase Cinemas</p> <p>Showcase Dearborn 1-8 Michigan & Telegraph 313-561-3449 Bargain Matinees Daily All Shows until 6 pm Continuous Shows Daily *Late Shows Fri. & Sat. & Sun. NP DENOTES NO PASS</p> <p>NP SCORPION KING (PG13) CLOCKSTOPPERS (PG) NP MURDER BY NUMBERS (R) NP CHANGING LANES (R) NP PANIC ROOM (R) NP FRALTY (R) BLADE 2 (R) NP THE SWEETEST THING (R)</p> <p>CALL FOR COMPLETE LISTINGS AND TIMES</p>	<p>Star John-R at 14 Mile 32289 John R. Road 248-585-2070 No one under 6 admitted for PG13 & R rated films after 6 pm</p> <p>NP THE SCORPION KING (PG13) NP MURDER BY NUMBERS (R) NP MY BIG FAT GREEK WEDDING (PG) NP FRALTY (R) NP THE SWEETEST THING (R) NP HIGH CRIMES (PG13) NP VAN WILDER (R) NP PANIC ROOM (R) NP THE ROOKIE (G) CLOCKSTOPPERS (PG) BLADE 2 (R) E.T. (PG) ICE AGE (PG) WE WERE SOLDIERS (R) BEAUTIFUL MIND (PG13)</p> <p>CALL FOR COMPLETE LISTINGS AND TIMES</p>	<p>Just North of the intersection of 14 Mile & Haggerty Rd 248-960-5801 *All Stadium Seating *High Back Rocking Chair Seats *Two-Day Advance Ticketing</p> <p>PLEASE CALL THEATER FOR SHOWTIMES AT 248-960-5801 or visit WWW.UATC.COM CALL FOR COMPLETE LISTINGS AND TIMES</p> <p>Birmingham 8 Uptown Birmingham 8 211 S. Woodward Downtown Birmingham 248-644-3456 NP Denotes No Pass Engagements Order Movie tickets by phone! Call 644-3456 and have your VISA or MasterCard ready! (A 5% surcharge per transaction will apply to all telephone sales)</p> <p>NP BEHIND THE SUN (PG13) NP MY BIG FAT GREEK WEDDING (PG) NP FRALTY (R) KISSING JESSICA STEIN (R) IRIS (R) MONSTER'S BALL (R) LORD OF THE RINGS: THE FELLOWSHIP OF THE RING (PG13) A BEAUTIFUL MIND (PG13) GOSFORD PARK (R) IN THE BEDROOM (R)</p> <p>CLASSIC FILM SERIES ALL THE PRESIDENT'S MEN (PG) CALL 644-FILM FOR INFORMATION CALL FOR COMPLETE LISTINGS AND TIMES</p>	<p>Waterford Cinema 16 501 Highland Rd 248-960-5801 S.E. corner M 59 & Williams Lake Rd 24 Hour Movie Line (248) 666-7900 CALL 77 FILMS #551</p> <p>WE'VE TRIPLED OUR LOBBY AND ADDED FIVE NEW SCREENS. THE ONLY THEATRE IN OAKLAND COUNTY WITH THE NEW DOLBY DIGITAL EX SOUND SYSTEM AND MORE. CHECK US OUT! OUR EXPANDED PARKING LOT IS NOW OPEN. FREE REFILL ON POPCORN AND POP.</p> <p>NP THE SCORPION KING (PG13) NP MY BIG FAT GREEK WEDDING (PG) NP MURDER BY NUMBERS (R) NP THE SWEETEST THING (R) FRALTY (R) NP CHANGING LANES (R) HIGH CRIMES (PG13) NP PANIC ROOM (R) THE ROOKIE (G) CLOCKSTOPPERS (PG) NP PANIC ROOM (R) THE ROOKIE (G) BLADE 2 (R) ICE AGE (PG) A BEAUTIFUL MIND (PG13)</p> <p>CALL FOR COMPLETE LISTINGS AND TIMES VISA & Mastercard Accepted</p>	<p>FRALTY (R) STATE PROPERTY (R)</p> <p>BARGAIN NIGHTS WEDNESDAY AND THURSDAY EXCEPT PINK ROOM</p> <p>69</p> <p>ALL ABOUT THE BENJAMINS (R) HOW HIGH (R)</p> <p>MURDER BY NUMBERS (R) THE NEW OF THE DAMNED (R)</p> <p>BLADE 2 (R) JOHN Q (PG13)</p> <p>HIGH CRIMES (PG13) PANIC ROOM (R)</p> <p>BARGAIN NIGHTS WEDNESDAY AND THURSDAY</p> <p>MOVIES START AT DUSK</p>
<p>Showcase Pontiac 2405 Telegraph Rd. East side of Telegraph 248-334-6777 Bargain Matinees Daily *All Shows until 6 pm Continuous Shows Daily Late Shows Fri. & Sat. NP DENOTES NO PASS</p> <p>NP SCORPION KING (PG13) NP MURDER BY NUMBERS (R) NP CHANGING LANES (R) NP THE SWEETEST THING (R) MONSTER'S BALL (R) PANIC ROOM (R) CLOCKSTOPPERS (PG) THE ROOKIE (G)</p> <p>CALL FOR COMPLETE LISTINGS AND TIMES</p>	<p>Star Rochester Hills 200 Barclay Circle 853-2260 No one under age 6 admitted for PG13 & R rated films after 6 pm</p> <p>NP MURDER BY NUMBERS (R) NP SCORPION KING (PG13) NP CHANGING LANES (R) NP SWEETEST THING (R) NP FRALTY (R) HIGH CRIMES (PG13) THE ROOKIE (G) PANIC ROOM (R) CLOCKSTOPPERS (PG) ICE AGE (PG) A BEAUTIFUL MIND (PG13)</p> <p>CALL FOR COMPLETE LISTINGS AND TIMES</p>	<p>Birmingham Palladium 12 Up Town Palladium 12 250 North of Old Woodward Ave Downtown Birmingham 248-644-FILM</p> <p>Featuring 12 stadium seating auditoriums with state-of-the-art wall to wall curved screens, Dolby Digital surround sound, two gran concession stands, valet parking, Little Caesar's Pizza, Ray's Ice Cream and the all new Premier Entertainment Auditorium</p> <p>MATINEE MOVIES \$5.75</p> <p>NP MURDER BY NUMBERS (R) NP SCORPION KING (PG13) NP CHANGING LANES (R) NP THE SWEETEST THING (R) PANIC ROOM (R) NATIONAL LAMPLOON'S VAN WILDER (R) THE ROOKIE (G) ICE AGE (PG)</p> <p>CALL FOR COMPLETE LISTINGS AND TIMES</p>	<p>Main Art Theatre III 118 Main at 11 Mile Royal Oak 248-542-0180 call 77 FILMS ext 542 (DISCOUNTED SHOWS!!!) TICKETS AVAILABLE AT THE BOX OFFICE OR PHONE 248-542-0180 VISA AND MASTERCARD ACCEPTED</p> <p>Y TU MAMA TAMBIEN (UNR) KISSING JESSICA STEIN (R)</p> <p>CALL FOR COMPLETE LISTINGS AND TIMES Children Under 6 Not Admitted</p>	<p>Cinemark Movie 16 The Best Seat in Town 28600 Dequindre Rd Warren MI 810-558-8207</p> <p>NP MURDER BY NUMBERS (R) NP THE SCORPION KING (PG13) NP MY BIG FAT GREEK WEDDING (PG) NP MURDER BY NUMBERS (R) NP THE SWEETEST THING (R) FRALTY (R) NP CHANGING LANES (R) HIGH CRIMES (PG13) NP PANIC ROOM (R) THE ROOKIE (G) BLADE 2 (R) ICE AGE (PG) A BEAUTIFUL MIND (PG13)</p> <p>CALL FOR COMPLETE LISTINGS AND TIMES VISA & Mastercard Accepted</p>
<p>Showcase Westland 1-8 6800 Wayne Rd 313-729-1060 Bargain Matinees Daily All Shows until 6 pm Continuous Shows Daily Late Shows Wed Thurs, Fri. & Sat. NP DENOTES NO PASS</p> <p>NP MURDER BY NUMBERS (R) PANIC ROOM (R) NP CHANGING LANES (PG) THE ROOKIE (G) NP SWEETEST THING (R) ICE AGE (PG) NP SCORPION KING (R)</p> <p>CALL FOR COMPLETE LISTINGS AND TIMES</p>	<p>Star Southfield 12 Mile between Telegraph and Northwestern 248-353-5749 No one under age 6 admitted for PG13 & R rated films after 6 pm</p> <p>Saturday Night is Family Night at Star Southfield! Star Theaters is committed to providing the best environment for family entertainment and to encourage families to get out to a movie. STAR SOUTHFIELD will provide a FREE SMALL POP and POPCORN to all kids 16 and under if accompanied by a parent to all shows after 8:30 pm. During our Family Saturdays, no movie 16 years and under will be permitted entry unless with a parent after 8:30 pm. so great Mom and Dad and HEAD FOR THE MOVIES!</p> <p>FOR SHOWTIMES AND TO PURCHASE TICKETS BY PHONE CALL 248-372-2222 WWW.STAR.SOUTHFIELD.COM</p> <p>NP SCORPION KING (PG13) NP MURDER BY NUMBERS (R) NP MY BIG FAT GREEK WEDDING (PG) NP CHANGING LANES (R) NP SWEETEST THING (R) NP FRALTY (R) HIGH CRIMES (R) NATIONAL LAMPLOON'S VAN WILDER (R) PANIC ROOM (R) THE ROOKIE (G) CLOCKSTOPPERS (PG) BLADE 2 (R) E.T. (PG) ALL ABOUT THE BENJAMINS (R) ICE AGE (PG) MONSTER'S BALL (R) A BEAUTIFUL MIND (PG13)</p> <p>CALL FOR COMPLETE LISTINGS AND TIMES</p>	<p>Maple Art Cinema III 4135 W. Maple West of Telegraph Bloomfield Hills 248-542-0180 DISCOUNTED SHOWS!!</p> <p>CRUSH (R) MONSOON WEDDING (R) LAST ORDERS (R) HUMAN NATURE (R)</p> <p>CALL FOR COMPLETE LISTINGS AND TIMES</p>	<p>Oxford 7 Cinemas, L.L.C. Downtown Oxford Lapeer Rd. (M 24) (248) 628-7100 Fax: (248)-628-1300</p> <p>DETROIT'S LOWEST FIRST RUN PRICES</p> <p>AMC Livonia 20 Haggerty & 7 Mile 734-542-9909</p> <p>CALL THEATRE FOR FEATURES AND TIMES</p> <p>\$1.00 Ford Tel \$1.50 313-561-7200 \$1.00 til 6 pm After 6 pm \$1.50 Ample Parking Telford Center Free Refill on Drinks & Popcorn Please Call Theatre for Showtimes</p> <p>JIMMY NEUTRON, BOY GENIUS (G) BIG FAT LIAR (PG) CROSSROADS (PG13) THE COUNT OF MONTE CRISTO (PG13)</p> <p>Ford Wyoming Drive-In Theatre Dearborn (313) 846-6910 Children Under 12 are Free Electric in Car Heaters</p> <p>ALWAYS TWO BIG PICTURES TOGETHER</p>	<p>Monday thru Friday FIRST SHOW OF THE DAY \$0.00 ALL SHOWS \$1.50 EXCEPT FRIDAY AND SATURDAY AFTER 6:00 PM ALL SEATS \$2.00 BARGAIN TUESDAY, ALL SHOWS AFTER THE FIRST SHOW \$1.00</p> <p>NP MURDER BY NUMBERS (R) NP THE SCORPION KING (PG13) NP MY BIG FAT GREEK WEDDING (PG) NP MURDER BY NUMBERS (R) NP THE SWEETEST THING (R) FRALTY (R) NP CHANGING LANES (R) HIGH CRIMES (PG13) NP PANIC ROOM (R) THE ROOKIE (G) BLADE 2 (R) ICE AGE (PG) A BEAUTIFUL MIND (PG13)</p> <p>CALL FOR COMPLETE LISTINGS AND TIMES</p>
<p>Star Theatres The World's Best Theatres Bargain Matinees Daily \$5.75 All Shows Starting before 6:00 pm Now accepting Visa & MasterCard *NP Denotes No Pass Engagement</p> <p>Star Great Lakes Crossing Great Lakes Shopping Center 248-454-0366</p> <p>NP MURDER BY NUMBERS (R) NP SCORPION KING (PG13) NP BIG FAT GREEK WEDDING (PG) NP Y TU MAMA TAMBIEN (UNR) NP FRALTY (R) NP CHANGING LANES (R) NP SWEETEST THING (R) HIGH CRIMES (PG13) BIG TROUBLE (PG13) NP NATIONAL LAMPLOON'S VAN WILDER (R) PANIC ROOM (R) ROOKIE (G) CLOCKSTOPPERS (PG) E.T. (PG) BLADE 2 (R) ICE AGE (R) SHOWTIME (PG13) TIME MACHINE (PG13) WE WERE SOLDIERS (R) JOHN Q (PG13) A BEAUTIFUL MIND (PG13) LORD OF THE RINGS (PG13)</p> <p>CALL FOR COMPLETE LISTINGS AND TIMES</p>	<p>United Artists Theatres Bargain Matinees Daily for all shows starting before 6:00 PM Same day advance tickets available. NV No VIP tickets accepted</p> <p>United Artists West River 9 Mile 2 Blocks West of Middlebelt 248-788-6572</p> <p>PLEASE CALL THEATRE FOR SHOWTIMES AT 248-788-6572 OR VISIT WWW.UATC.COM CALL FOR COMPLETE LISTINGS AND TIMES</p> <p>United Artists Commerce Township 14 3330 Spornvale Drive Located Adjacent to Home Depot</p>	<p>Maple Art Cinema III 4135 W. Maple West of Telegraph Bloomfield Hills 248-542-0180 DISCOUNTED SHOWS!!</p> <p>CRUSH (R) MONSOON WEDDING (R) LAST ORDERS (R) HUMAN NATURE (R)</p> <p>CALL FOR COMPLETE LISTINGS AND TIMES</p>	<p>Oxford 7 Cinemas, L.L.C. Downtown Oxford Lapeer Rd. (M 24) (248) 628-7100 Fax: (248)-628-1300</p> <p>DETROIT'S LOWEST FIRST RUN PRICES</p> <p>AMC Livonia 20 Haggerty & 7 Mile 734-542-9909</p> <p>CALL THEATRE FOR FEATURES AND TIMES</p> <p>\$1.00 Ford Tel \$1.50 313-561-7200 \$1.00 til 6 pm After 6 pm \$1.50 Ample Parking Telford Center Free Refill on Drinks & Popcorn Please Call Theatre for Showtimes</p> <p>JIMMY NEUTRON, BOY GENIUS (G) BIG FAT LIAR (PG) CROSSROADS (PG13) THE COUNT OF MONTE CRISTO (PG13)</p> <p>Ford Wyoming Drive-In Theatre Dearborn (313) 846-6910 Children Under 12 are Free Electric in Car Heaters</p> <p>ALWAYS TWO BIG PICTURES TOGETHER</p>	<p>Monday thru Friday FIRST SHOW OF THE DAY \$0.00 ALL SHOWS \$1.50 EXCEPT FRIDAY AND SATURDAY AFTER 6:00 PM ALL SEATS \$2.00 BARGAIN TUESDAY, ALL SHOWS AFTER THE FIRST SHOW \$1.00</p> <p>NP MURDER BY NUMBERS (R) NP THE SCORPION KING (PG13) NP MY BIG FAT GREEK WEDDING (PG) NP MURDER BY NUMBERS (R) NP THE SWEETEST THING (R) FRALTY (R) NP CHANGING LANES (R) HIGH CRIMES (PG13) NP PANIC ROOM (R) THE ROOKIE (G) BLADE 2 (R) ICE AGE (PG) A BEAUTIFUL MIND (PG13)</p> <p>CALL FOR COMPLETE LISTINGS AND TIMES</p>



Contemporary comedy: Studio head Hal Yeager (Treat Williams, left to right), and his fiancée Ellie (Tea Leoni) run into director Val Waxman (Woody Allen) and his actress girlfriend Lori (Debra Messing) in a scene from "Hollywood Ending."

Festival from page B1

Jewish children by transporting them to safety, is moving because Winton is still alive to tell the story. Realizing the impact that hearing about the risky venture first hand could have on an audience, Czech director Matej Minac made the film after finishing *All My Loved Ones*, a fictionalized version of Winton's heroic effort. Both will be shown on Sunday, May 5, *All My Loved Ones* in Birmingham in the afternoon, *The Power of Good: Nicholas Winton* in Ann Arbor in the evening. As a special bonus Winton and Minac be present for a reception before the evening showing and after the film. Tickets are limited and reservations must be made by calling (248) 788-2900 or (734) 971-0990 by Wednesday, May 1

Collaboration

The showing and event are a result of a collaboration between the Jewish Community Center of Washtenaw and the Jewish Community Center of Metropolitan Detroit. "We had 8,100 people view last year's films. Ninety-eight percent of the seats were filled so we added more seats, more performances," said Magidson. "It takes nearly a year of planning and holding feedback meetings to ask audiences what they like then in July we gather films to preview and try to pick by December. "We're looking for films of interest to general audiences with Jewish interests - things that are entertaining but not just entertainment, things that are thought provoking and go beyond the issue. We would like it not to be over when people leave the theater." There's comedy too, Crunch Bird cartoons and other lighter fare. A new re-mastered print of the 1942 Jack Benny movie, *To Be or Not to Be*, tells the story of a Polish acting troupe that foils Hitler's plan and saves thousands of lives. *The Ballad of Ramblin' Jack* tells the story of folk singer Jack Elliot who along with Woody Guthrie, Peter Yarrow and Joan Baez tried to change the world with song. All of the films are probably ones Milton and Lenore Marwil would have loved to watch before they were married. The legend goes that the two courted at the movies and that was the reason Milton created a \$250,000 endowment for the festival four years ago in honor of his late wife Mil-

ton died in January but their love of movies lives on through the festival because of his generous gift. Each festival costs more than \$85,000 to produce, and while ticket sales make up a major portion of the budget, grants from Michigan Council for Arts & Cultural Affairs and the Oakland County Cultural Mm Grant program along with several sponsors make the movie extravaganza possible. "It's a community effort. We have 80-100 volunteers, a committee at large and a small committee of four to view the films," said Magidson who was a volunteer the first year and now in his third year as festival director. Magidson considers himself a part of the entertainment business which has as many failure

stories as successes. A theater professor at Wayne State University and director of the Center for Arts and Public Policies, Magidson has taught film and TV writing, directed nearly 100 plays and produced 250. *His Sisters Rosen zweig* is currently in rotating repertory through Saturday, May 4 at the Hilberry Theatre. Magidson will direct the season opener, Neil Simon's *The Good Doctor*, there in fall. "I like the movies. My business is show business," said Magidson. "We try to make it as exciting as we can but as a business-like as we can. There's a perception that this is easy. You put on a film festival and walk away with a pocket full of money."

Jewish Community Center Lenore Marwil Jewish Film Festival					
Films are shown at these locations:					
<ul style="list-style-type: none"> United Artists Theatres, 14 Mile and Haggerty Roads, Commerce Twp. (CT) Birmingham 8 Theatres on Old Woodward south of Maple, Birmingham (B) Michigan Theatre, 603 E. Liberty, Ann Arbor 					
Sunday, April 28 - Wednesday May 8, 2002					
Day/Time	12:30 p.m.	2 p.m.	3 p.m.	5 p.m.	8 p.m.
Sunday, April 28	Conversation with George Burns Mame drama (CT)		Fighter (CT)	n Search of Peace (CT)	One of the Holywood Ten (CT)
Monday, April 29				Good Evening Mr. Wallenberg (CT)	One Day in September (CT)
Tuesday, April 30		Hester Street (CT)		Ballad of Ramblin' Jack (CT) Time of Favo (B)	Let's Get Frank (CT) Times of Harvey Milk (CT) Crusade of the Holywood Ten (B)
Wednesday, May 1				Blue & White in Red Square (CT) Fath & Fourtune (CT) Once We Grow Up (B)	Time of Favo (CT) Left Luggage (B)
Thursday, May 2		Terrorist n Retirement (CT)		It Happened Here (CT)	Once We Grow Up (CT)
Saturday, May 4					(8:45 pm) To Be or Not to Be Crunch Bird's Meet the Yenta & Goller (CT)
Sunday, May 5	Adlo Kertida New R mmakers Forum (CT)		All My Loved Ones (CT)	Inside Out (CT)	Left Luggage (CT)
Ann Arbor/Days and Times					
Day/Time	5 p.m.			8 p.m.	
Sunday, May 5					The Power of Good: Nicholas Winton
Monday, May 6				Time of Favo	One of the Holywood Ten
Tuesday, May 7				The Ballad of Ramblin' Jack	Once We Grow Up
Wednesday, May 8				It Happened Here	Left Luggage

Open up and see Ultimate Fakebook

Tune out *The Osbournes* already Not since the pop antics of The Monkees

STREET SCENE



STEPHANIE CASOLA

has a band been as deserving of its own TV show as the always entertaining Ultimate Fakebook

Take one singer - who'd slide seamlessly into place in a band like Weezer - complete with black rimmed glasses and sweaters you'd swear he stole from Mister Rogers Hand him a guitar and a mic

Add in his alter ego - a taller, more muscular Mr Clean hunched happily over his bass guitar, grinning like a madman

Then complete the trio with a wild drummer who looks a bit like Dave Grohl but probably spent more of his childhood dreaming of an appearance in *Kiss Meets the Phantom of the Park*

Ultimate Fakebook is Bill McShane, Nick Colby and Eric Melin The trio hails from Kansas - a place where it's apparently still safe to embrace the melodic rock of late 80s radio and metal from MTV's *Headbanger's Ball*

The band even titled their third and latest CD with the very tongue-in-cheek *Open Up and Say Awesome!*, playing on the hair metal heyday of Poison's *Open Up and Say Ahh*

"We thought of it a while back," said Bill McShane, singer-guitarist of UFB "I think it started as a joke We came up with all these titles All these

The trio hails from Kansas - a place where it's apparently still safe to embrace the melodic rock of late 80s radio and metal from MTV's Headbanger's Ball.

serious titles They got no response We finally realized we're taking ourselves too seriously'

The record plays a worthy sequel to the band's 2000 release *This Will Be Laughing Week* It doesn't take any unexpected musical turns It isn't an arty concept album 'We stayed pretty true to our original plan,' said McShane

Think of it as the next chapter of rollercoaster rock anthems and contagious true blue love songs Where *Laughing Week* offered *Tell Me What You Want, Open Up* screams out G**damn *Dance Craze* McShane serenades with the dreamy pop of *Forever Forever* rather than *A Million Hearts*

McShane had hoped the song *Gurl Here's Another Lie* could be a duet with *Grease* superstar Olivia Newton John "I was totally infatuated," he said of his childhood crush But all he got was rejection "At least we got that much," he said

Special guests on *Open Up and Say Awesome!* include James DeWees and Matt Pryer from The Get Up Kids "We had just finished doing the Reggie & The Full Effect Tour with them," said McShane "We'd been hanging out a lot with them We'd recorded an EP split with them"

So asking them to stop by Red House Studios for a little help wasn't a stretch DeWees dropped in some Muzak style keyboards on the gushy but great *Forever Forever* And Pryer crooned background vocals on *Combat Fatigue*

The record also features guitar work by Stephen Egerton (The Decedents/All), who's also a fan

The band seems able to fit in with so many different artists UFB has toured with the likes of MXPX, Sloan and Dashboard Confessional 'Ska bands, boy band punk to emo kids we're non-discriminating against who we'll rock with or for,' said McShane

UFB fans - the ideal of which make home made tee shirts and sing along to every word - come in all types McShane describes the quintessential fan as "being like us being a complete dork, that's my favorite kind"

Open Up and Say Awesome! was made for them - complete with 12 number one hit singles - said McShane, seeming to give an audible grin

Look for a lot more from UFB this year The trio has a split EP



Air guitar anyone? Nick Colby (left to right), Bill McShane and Eric Melin are Ultimate Fakebook Grab a copy of their latest CD, *Open Up and Say Awesome!* on Initial Records

with Reggie & the Full Effect still expected for release Thanks to the marvel that is digital video, they are also in the process of filming songs like *Valen tines* and *When I'm With You I'm OK But Inside Me Inside You* is likely to be the song and video they'll send to MTV2 Extra footage might be released as a bootleg home video

UFB will make it to Canada and to Europe on tour for the first time They'll even join the Warped Tour this summer and are likely openers for Ann Arbor native and latest rock sensation Andrew W K during his West Coast tour

Ultimate Fakebook rocks Detroit Tuesday May 7 The Shelter, below St Andrews Hall 431 E Congress Call (313) 961 MELT Learn more about the band at www.ultimatefakebook.com

Stephanie Angelyn Casola writes about popular music for the Observer & Eccentric Newspapers She can be reached at (248) 625 1900 ext 12 or via e mail at scasola@oe.com

HOUSEHOLD HINTS • HOUSEHOLD HINTS • HOUSEHOLD HINTS

HOUSEHOLD PROBLEMS?
Tune-in Bob Allison's *Ask Your Neighbor*

(WNZK 690 AM • Mon.-Fri. 9 am 11 am)

- How to Cook It
- How to Do It
- Where to Find It

www.askyourneighbor.com

HOUSEHOLD HINTS • HOUSEHOLD HINTS • HOUSEHOLD HINTS

Observer Classifieds sell!
Call 800-579-SELL today!

summer ART CAMP 2002
Have an artistic summer!

ART CAMP 1: June 17-28
ART CAMP 2: July 8-19

REGISTER NOW!
Space is limited

ART CAMP IS AN OPPORTUNITY FOR CHILDREN TO COMBINE CREATIVITY AND FUN TO DEVELOP ARTISTIC TALENTS AND EXPLORE NEW MEDIA UNDER THE GUIDANCE OF A PROFESSIONAL STAFF STUDENTS ARE GROUPED BY GRADE LEVEL AND WILL ENJOY A VARIETY OF AGE APPROPRIATE BASED ACTIVITIES
Before and after care available

WWW.BBARTCENTER.ORG
(248) 644-0866
1516 SOUTH CRANBROOK ROAD
BIRMINGHAM MI 48009

ArtCenter
SPONSORED BY THE OBSERVER & ECCENTRIC NEWSPAPERS

"TWO THUMBS UP!"

MY BIG FAT GREEK WEDDING

Love is here to stay so is her family

AMC FORUM 30 | AMC LIVONIA 20 | BIRMINGHAM 8
MJR SOUTHGATE 20 | SHOWCASE STERLING HTS. | STAR GRATIOT
STAR GREAT LAKES CROSSING | STAR JOHN R | STAR SOUTHFIELD

EVIL GETS AN UPGRADE!

JASON

AMC FORUM 30 | STARTS FRIDAY APRIL 26 | AMC LIVONIA 20
BEACON EAST | MJR SOUTHGATE 20 | NOVI TOWN CENTER 8 | PHOENIX AT BEL AIR CENTER
SHOWCASE DEARBORN | SHOWCASE PONTIAC | SHOWCASE STERLING HTS. | SHOWCASE WESTLAND
STAR FAIRLANE | STAR GRATIOT AT 15 MILE | STAR GREAT LAKES CROSSING | STAR JOHN R AT 14 MILE
STAR LINCOLN PARK 8 | STAR ROCHESTER HILLS | STAR SOUTHFIELD | STAR TAYLOR
UA COMMERCE STADIUM | WHITE WEST RIVER | UPTOWN PALLADIUM 12 | NO PASSES OR COUPONS ACCEPTED

WIN FREE TICKETS!

Meadow Brook Theatre
OAKLAND UNIVERSITY'S PROFESSIONAL THEATRE COMPANY

Godspell
The Classic Rock Musical!
APR 24 - MAY 19

Music and new lyrics by Stephen Schwartz
Book by John Michael Tebelak

High energy rock n roll makes Godspell a plugged in circus romp retelling of the Gospel According to St Matthew Great songs like Day by Day are just part of this exuberant life affirming celebration s rign spirits The New York Times cheered Godspell still has the giddy rapture that made it a hit!

MBT RATING SUITABLE FOR OLDER CHILDREN

Tickets start at just \$17!
MBT BOX OFFICE
(248) 377-3300
GROUP DISCOUNTS (248) 370 3316
www.mbtheatre.com

Made possible by **metaldyne**

COUPLES NIGHT! Buy one ticket, get second half price! Wed, Thurs & Sun nights.

Win Tickets to See MBT's

See today's O&E classified ads - Section 751, Musical Instruments - for the winning answer! Send postcard with the correct answer, your name address & daytime phone to GODSPELL CONTEST, Meadow Brook Theatre Oakland University Rochester, MI 48309 five winners will be randomly selected from entries with correct answers received by Wednesday May 8th

"TWO VERY BIG THUMBS UP! ONE OF THE YEAR'S BEST FILMS!"

CHANGING LANES

AMC FORUM 30 | AMC LAUREL PARK | AMC LIVONIA 20
BEACON EAST | BIRMINGHAM PALLADIUM | MJR SOUTHGATE 20
PHOENIX AT BEL AIR CTR. | SHOWCASE DEARBORN | SHOWCASE PONTIAC
SHOWCASE STERLING HTS. | SHOWCASE WESTLAND | STAR FAIRLANE 21
STAR GRATIOT | STAR GREAT LAKES CROSSING | STAR JOHN R
STAR LINCOLN PARK | STAR ROCHESTER | STAR SOUTHFIELD
STAR TAYLOR | UA COMMERCE STADIUM | UA WEST RIVER

"THE HOTTEST SUSPENSE THRILLER TICKET IN TOWN!"
BULLOCK IS INCREDIBLE!

"EERIE AND SHOCKING! BULLOCK IS TERRIFIC!"

SANDRA BULLOCK
MURDER BY NUMBERS
LET THE MIND GAMES BEGIN

AMC FORUM 30 | AMC LAUREL PARK | AMC LIVONIA 20
AMC WONDERLAND | BIRMINGHAM PALLADIUM | MJR SOUTHGATE 20
NOVI TOWN CTR. 8 | SHOWCASE DEARBORN | SHOWCASE PONTIAC
SHOWCASE STERLING HTS. | SHOWCASE WESTLAND | STAR FAIRLANE 21
STAR GRATIOT | STAR GREAT LAKES CROSSING | STAR JOHN R
STAR LINCOLN PARK | STAR ROCHESTER | STAR SOUTHFIELD
STAR TAYLOR | UA COMMERCE STADIUM | UA WEST RIVER

Festival features world music, dance

BY KEELY KALESKI WYGONIK
KWYGONIK@OE.HOMECOMM.NET

When like minded people get together amazing things can happen

"You have to work and collaborate with people who have new ways of looking at things. But first you have to give yourself permission to explore," said flutist Ginka Gerova Ortega, artistic director of Musica Viva! which will present a Festival of World Music and Dance, Friday, May 10 at the Smith Theatre on Oakland Community College's Orchard Ridge campus in Farmington Hills. "The world is very small. You carry it with you."

Biakuye (Unity) African Drums Ensemble, singer Shu Ping, the Motor City Milongueros Tango Dancers, the Tango Para Siempre Group, and Grupo



Ginka Gerova Ortega

Musica Viva featuring Ortega, Emily Kiesler, cello, Glenn Bering, percussion, Julian Devoux, bayan, and Juan Herrera, guitar will perform. "I'm very much into world

'You have to work and collaborate with people who have new ways of looking at things. But first you have to give yourself permission to explore. The world is very small. You carry it with you.'

Ginka Gerova Ortega
Flutist, artistic director of Musica Viva!

music now," said Ortega who was trained as a classical flutist and studied with Jean Pierre Rampal. "I like the melodies and rhythm. The soul of Latin music is flute. I am surprising myself by how much of what I love is so

easy - it just comes to me."

World music was not popular when Ortega started the Musica Viva! World concert series 20 years ago. Now it's norm.

"My silent gesture has a loud voice," she said. "We are part of a universe that is awakening. We are the ones who make a difference. Our lives are a white canvas. Every day I ask myself, 'how am I going to make a difference?' We are small but we can do big things."

Each Musica Viva concert is like a microcosm of the world, she says. This concert will showcase music from three continents and 10 countries - from the mysteries of African drums, to the lush melodies of China, and Latin American tango.

Ortega heard Biakuye in Ann Arbor and was very impressed

with the group's authenticity. One of its members, Mark Stone, is a scholar who has studied west African music.

"What I am trying to do is create new sounds and instrumentation," said Ortega as she explained the music of Grupo Musica Viva. "This kind of combination of instruments is very rare, therefore you hear a new kind of sound with a classical base, but a new twist that explores different colors of the instrumentation. We are exploring the music of Latin America and taking it to another level."

Ortega just returned from Paris where she performed a tribute concert in memory of the one year anniversary of Rampal's passing. This summer she will perform for the International Festivals in Spain and in Mexico

Festival of World Music and Dance

What: An exotic journey in song and dance, from the mysteries of the African drums, to the voices of China, to the passionate sounds of Latin America.

When: 8 p.m. Friday, May 10

Where: Smith Theatre, Oakland Community College, Orchard Ridge campus, Orchard Lake Road, south of 12 Mile Road, Farmington Hills

Tickets: \$16 in advance, \$18 at the door. \$25 reserved. (248) 522-3667

City in September. She is a resident of Bloomfield Hills, and was recently recognized for her contribution to the metro Detroit cultural scene by CORP! magazine.

SATURDAY, APRIL 27

WHAT'S INSIDE
7:00 am - 2:00 pm

One Day Only OPEN HOUSE SALE
All in-store, in-stock merchandise up to **25% OFF**. Great deals on deck finishes, lawn and garden supplies, tools, hardware and much more.

WHAT'S OUTSIDE
9:00 am to finish

CLEARANCE AUCTION
Surplus Inventory, Scratch & Dent Sale!

Doors	Windows	Cabinets	Countertops	Lumber	Cedar Decking
Calling Tiles	Power Tools	Molding	Plumbing	Paint	Medical
Headings	and more				

NO MINIMUM BIDS Auctioneer Ron Tosch
Free food, beverages & give-aways

Family owned since 1910
DILLMAN & UPTON
FULL SERVICE HOME CENTER, SHOWROOM & LUMBERYARD
607 Woodward Street - Rochester, Michigan
248-651-9411 dillmanupton.com

Youth unite to share a spring song

Nearly three years ago, the Livonia Youth Choir came together to share the pleasure of song. On Saturday, April 27, they present their annual concert of works ranging from classical to folks songs from around the world at 7 p.m. in Faith Lutheran Church, 30000 Five Mile Road, west of Middlebelt, Livonia.

Almost 50 boys and girls in grades 4-8 from Livonia and sur-

Almost 50 boys and girls in grades 4-8 from Livonia and surrounding communities make up the choir.

rounding communities make up the choir. Admission is free.

An on-going effort, the youth choir is now looking for new

members as well as a music director. Interested persons for the director position should have a degree in music performance or music education, and a demonstrated interest and love of working with young people. Auditions for choir members will be held in September for girls and boys (with unchanged voices) who will be in grades 4-8 in the new school year. For more information, call (734) 425-1749.

www.HomeTownLife.com

INTERNET ADDRESS DIRECTORY

ACUPUNCTURE Carl J. Sarnacki M.D. www.americanacupuncture.com	EYE CARE/LASER SURGERY Greenberg Laser Eye Center www.greenbergeye.com Michigan Eyecare Institute www.micheyecare.com
APARTMENT Can Be Investments www.can.be.com	FLOORING Dande Hardwood Flooring Company www.dandefloors.com
ARCHITECTS URS Greiner Woodward Clyde www.urscorp.com	FROZEN DESSERTS Savino Sorbet www.sorbet.com
ART and ANTIQUES	GALLERIES Cowboy Trader Gallery www.cowboytradergallery.com
ART MUSEUMS The Detroit Institute of Arts www.dia.org	HOME IMPROVEMENTS Accent Remodeling Inc. www.accentremodeling.com
ASPHALT/CONCRETE PAVING Ajax Paving Industries www.ajaxpaving.com	IDENTIFICATION & LAMINATION Identification Lamination Products www.identlam.com
ASSOCIATIONS Oakland Youth Orchestra www.oyom.org Suburban Newspapers of America www.suburbannews.org Suspenders Wearers of America http://oonline.com/swaa	INSURANCE J. J. O'Connell & Assoc. Inc. www.oconnellinsurance.com
AUDIO VISUAL SERVICES AVS Audio www.avsaudio.com	MANUFACTURER'S REPRESENTATIVES Electronic Sources www.esirep.com
AUTOMOTIVE Auto Extend Warranty autoextendwarranty.com Competition Limited www.htnews.com/comp Ltd Davis Auto Care davisautocare.com Great Lakes Components www.greatlakescomponents.com John Rogin Buick Isuzu-Suzuki www.johnrogin.com	MEDICAL SAVINGS PROGRAMS Gerard Cangian, Care Entire Representative www.carehealthcarecosts.com
AUTO RACING Milan Dragway www.milandragway.com	MEDICAL SUPPLIES Innovative Laboratory Acrylics www.innovativelaboratoryacrylics.com
BAKING/COOKING "Jiffy" Mix—Chelsea Milling Company www.jiffymix.com	MUSIC MEMORABILIA Classic Audio Repro www.classicaudiorepro.com
BIBLE STUDY Palmer Road Church of Christ www.prchurchofchrist.org	REAL ESTATE AMP Building www.ampbuilding.com Birmingham Bloomfield Rochester South Oakland Association of Realtors www.justlisted.com Century 21 Town & Country www.century21towncountry.com Detroit Association of Realtors www.detroitassocofrealtors.com Langard Realtors www.langard.com Max Brook Inc. www.maxbrook.com Quality Real Estate www.qualityrealestate.com Real Estate One www.realestateone.com Sellers First Choice www.sfchoice.com Weir, Manuel, Snyder & Ranke www.wermanuel.com Western Wayne Oakland County Association of Realtors® www.wvocar.com
BOOKS Apostolate Communications www.apostolate.com	REAL ESTATE AGENTS Bob Taylor www.bobtaylor.com
BUSINESS NEWS Insider Business Journal www.insiderbiz.com	REAL ESTATE APPRAISAL BBRSOAR Appraisers Committee http://justlisted.com/appraisal
CHAMBERS OF COMMERCE Ann Arbor Chamber of Commerce annarbor.org Birmingham/Bloomfield Chamber of Commerce -bbcc.com Livonia Chamber of Commerce -livonia.org Northville Chamber of Commerce northville.org Novi Chamber of Commerce novi.org Redford Chamber of Commerce redfordchamber.org	REAL ESTATE EDUCATION Real Estate Alumni of Michigan www.ramadantage.org
CHILDREN'S SERVICES St. Vincent & Sarah Fisher Center http://oonline.com/svsf	REPRODUCTIVE HEALTH Asghar Afsan M.D. www.gyndoc.com Midwest Fertility and Sex Selection Center www.mfss.com Center for Reproductive Medicine & Fertility www.reproductive-medicine.com
CHILD SAFETY ITEMS Knifesafe www.knifesafe.com	RESTAURANTS Albans Restaurant www.albans.com
CLASSIFIED ADS HomeTown Newspaper http://hometownlife.com Observer & Eccentric Newspapers http://observerandeccentric.com	RETIREMENT COMMUNITIES Presbyterian Villages of Michigan www.pvm.org Woodhaven Retirement Community www.woodhavenretirement.com
COMMUNITY NEWS HomeTown Newspapers http://htnews.com Observer & Eccentric Newspapers http://observereccentric.com	SHOPPING Birmingham Principal Shopping District http://oonline.com/birmingham
COMMUNITY SERVICES Beverly Hills Police www.beverlyhillspolice.com Common Ground Sanctuary commongroundsanctuary.org Detroit Regional Chamber www.detroitregionalchamber.com Hearts of Livonia www.heartslivonia.org	SURPLUS FOAM McCullough Corporation www.mccofoam.com
CREDIT BUREAUS Ann Arbor Credit Bureau www.a2cb.com	SURPLUS PRODUCTS McCullough Corporation www.mcsurplus.com
CRAFTS Linden Lane Farms www.fibersofmichigan.com	TOYS Toy Wonders of the World www.toywonders.com
DENTISTS family dentist www.familydentist.com Novi Dental novidental.com Smile Maker www.smilemaker.org	TRAVEL AGENCY Cruise Selections Inc. www.cruiseselections.com
DOLLS Toy Wonders of the World Inc. www.toywonders.com	WEB SITE DEVELOPMENT HomeTown Digital htdconnect.com
EDUCATION Oakland Schools http://oakland.k12.mi.us Rochester Community The Webmaster School http://rochesterhills.com	WHOLISTIC WELLNESS Roots and Branches www.reikiplace.com
ELECTRONIC SERVICE AND REPAIR ABL Electronic Service Inc. www.ablserve.com	WOODWORKING Art Squared www.artsquared.com
EMPLOYMENT SERVICES Advantage Staffing www.astaff.com	WORSHIP First Presbyterian Church Birmingham www.http://fpcbirmingham.org Rochester First Assembly Church www.rochesterfirst.org Unity of Livonia http://unityoflivonia.org
	YOUTH ATHLETICS Westland Youth Athletic Association www.wyaa.org

Luxury Senior Apartment Homes

Visit us during our **OPEN HOUSE** Friday, Saturday and Sunday April 26th, 27th and 28th from 12:00 - 6:00 p.m.

Refreshments
Complimentary lunch
Register to win a trip for two at Mackinac Island!

Royal Oak
Waltonwood of Royal Oak
Assisted Living
3450 West Thirteen Mile Road
(248) 549-6400
www.waltonwoodroyalok@singhmail.com

Beautiful studio and one bedroom apartment homes
Selection of services available
Courtesy transportation
Daily social events and activities
Excellent location
So much more!

Assisted Living

NO ENTRANCE FEES

SINGH

WHY BUY TORO ANYWHERE ELSE?

Model 20016
Self Propelled
\$299.00*

- 22" cutting width
- 6.5 Horsepower
- Variable speed self propelled
- Front wheel drive
- Hi-Wheel
- Mulch, side discharge & rear bag
- 2 year starting guarantee**

Model 20018
Electric Start
\$399.00*

- 22" cutting width
- 6.5 Horsepower
- Personal Pace® Drive
- Mulch, side discharge & rear bag
- 2 year starting guarantee**

TORO "PRO" SERVICE DEALER OFFERS:
Knowledgeable Sales Staff
Competitive Prices
Available Equipment Set ups
Trained Service Technicians
Complete Product Selection
Available Pick up & Delivery
Original Replacement Parts

*Prices may vary by dealer
**See dealer for details

See your local "Pro" Service Dealer

BRIGHTON H&R Power Equipment 5973 Meridian Rd. LIVONIA H&R Power Equipment 27430 Joy Rd.	FARMINGTON HILLS Weingartz 39050 Grand River ROYAL OAK Billings Feed Store 221 N. Main WATERFORD Weingartz 5395 Dixie Hwy.	LIVONIA Commercial Lawnmower 32098 Plymouth Rd. UTICA Weingartz 5395 Vandyke
---	---	---

www.toro.com
When you want it done right.™

Put your business On-Line!, call 1-800-989-4614

Detroit Electronic Music Festival brings back the beats for Memorial weekend

It's official, the world's premier electronic party plugs in again next month.

The third annual Detroit Electronic Music Festival will hit Hart Plaza from noon to midnight Sunday-Tuesday, May 26-28. The free festival originated with Planet E guru Carl Craig and Detroit-based Pop Culture Media. It now lies in the hands of a board of directors chosen by festival producer — and a Plymouth resident — Carol Marvin, who owns Pop Culture Media.

The DEMF's 2000 premiere drew more than a million people to the city's waterfront for a legendary three days of pulsating beats and visitors from across the globe. This time the stage is set for legends like George Clinton, those who helped the festival get off the ground like DJ Bone and of course Godfathers of techno like Juan Atkins and Kevin Saunderson.

■ This time the stage is set for legends like George Clinton, those who helped the festival get off the ground like DJ Bone and of course Godfathers of techno like Juan Atkins and Kevin Saunderson.

Still going strong, the artist line up for DEMF 2002 is as follows:

Sundiata, Chad Novak, Electric Indigo, Heather Heart, Gene Farris, DJ Zap, Mike Grant, Steve Rachmad, Dave Angel, Kevin Saunderson, Juan Atkins, Shorty, John Collins, Reggie Curry, T Linder, Jon Tejada, Boo Williams, Cas Roc, Frankie Knuckles, DJ Shadow, Sarena Tyler, X-Ecutions, Adam X, Black Eyed Peas, Bryan Zentz,

Blake Baxter, Roni Size, Eddie Fowikes, Mike Dearborn, George Clinton, Art Payne/Keith Martin, Gary Martin, Rick Wade, Paul Johnson, Drexciya, Ethan Kline, Derrick Thompson, Kenny Dope, Bone, Dave Clark, Roy Davis, Jr., Dennis Cox, Frankie Bones, K Hand, DJ Funk, Rob Hood, Colin Dale, Dwayne Jensen, Steve Tang, Greg Collier, Matt Clark, Melvin Hill, Mike Huckaby, DJ Dangerous, Ron Carroll, T-1000 and Traxx.

Performers with live sets include Erotok, Mad Professor, Bill Beaver, DeepChord, Advent, Chaos, Green Velvet, A Number of Names, Stewart Walker, Black Bottom Collective, and Scott Grooves with DJ and live sets.

For updates, a complete schedule and information on volunteer opportunities, see www.electronicmusicfest.com

By S A Casola

Exhibit from page B1

composition," Pujdowski said "It was very inventive."

Lucas has done a whole series of works on Africa, almost 10 so far, although she has never seen the country.

"I have a cousin who was a missionary there," she explained "This was done from imagination."

An artist for the past three decades, Lucas said she does a little of everything, from teaching to three-dimensional art and, of course, watercolor.

That's also Pujdowski's first love "I just gravitated toward it," he said, adding that had no real effect on the outcome of the competition.

He was very impressed by the entire show, which he was judging for the first time. Co-chair Nancy Walls Smith, a Plymouth resident, was thrilled to have two of her artworks juried.

Abloomin' tree and *Tucson scene* are both watercolors. The benefit of entering a juried show, Smith said, has to do with the

difference between creating art for art's sake and having one's creation seen by others.

"It's so wonderful when people look at your work," she said "It's satisfaction."

More than 150 artists currently belong to the club, and people from all over the area are always interested when the annual show is announced, Smith said. Juried entries will be on display during the Farmington Festival of the Arts, held April 28-May 5 at the Costick Center.

Chomin from page B1

styles of playing in every country. Trying to learn a Rachmaninov sound is difficult. It's powerful and intense. Your fingers have to be strong. In Paris I'm working on different forms of style. My teacher believes all pieces should be played in their own style. She's not really a Parisian teacher even though there is a French school.

"Studying in Russia and Paris has made me realize how strong Michigan is for music. The young students here are excelling fast."

Success

Mody attributes his success to teacher Donald Morelock. Since beginning his studies with Schoolcraft music department chairman, Mody has won first place in the Rochester Symphony Youth Artist Competition and Michigan Music Teacher's Association solo and piano concerto competitions. On June 20, he'll perform as a soloist at the Con-

certgebouw in Amsterdam, Holland.

"We have a chemistry," said Mody about Morelock. "We can do things fast. We're very close. I needed that support from him. I think a pianist, if they're focused, can do something in two weeks. They have to be absolutely consumed. Chopin wrote the concerto I'm playing with the Livonia Symphony when he was 19."

Morelock is as fond of Mody as the young pianist is of him. Morelock's been traveling back and forth to Europe since finding out Mody's father was being transferred to Paris. Morelock helped the family research music education offerings in France.

"Sanjay is a very special as a person and musician. I'm very proud of him," said Morelock. "He's studying with a prominent teacher. The French have many conservatories and a unique way of teaching."

Mody is quick to add that

Livonia Symphony Orchestra

What: Spotlights 15-year-old pianist Sanjay Mody in Frederic Chopin's *Concerto No. 1 in E minor for Piano & Orchestra*.
When: 7:30 p.m. Saturday, April 27.
Where: Churchill High School auditorium, 8900 Newburgh north of Joy Road, Livonia.
Tickets: \$16, \$10 students age 13 and over, no charge for children age 12 and younger. Call (734) 425-4855 or (248) 645-6666.

"studying in Paris is incredible. It really feels that the year has gone so fast."

Have an interesting idea for a story? Call Observer & Eccentric arts reporter Linda Ann Chomin at (734) 953-2145 or send e-mail to lchomin@oe.homecomm.net

YOU WON'T MISS A THING WITH LET'S GO!

Please join us for an evening of laughter, food and fun for a great cause...



Big Night Out IV

STROLLING SUPPER
SILENT AUCTION

featuring
Wendy Liebman
voted "Best Female Stand-Up" Comic"
Thursday, May 16th
Southfield Centre for the Arts
TICKETS START AT \$150

all proceeds benefit Gilda's Club Metro Detroit. A free non-profit support community for anyone touched by cancer.

Sponsored in part by THE Observer & Eccentric

For more information, call 248-577-0800 x22 or visit us at www.gildasclubdetroit.org

COMING ATTRACTIONS

FOR THE MONTH OF APRIL

Reach thousands of potential customers by advertising in our Holiday

Flower Directory

MOTHER'S DAY 2002

By placing your ad on this page potential customers will know you're ready to fill their holiday needs. A great reminder that beautiful, fresh flowers are the perfect Easter holiday greeting.

For more information call

Tara Eddington

(734) 953-2094 or

Lindsay Scheffer

(734) 953-2095

FAX (734) 953-2232

Deadline:.....May 1st
Run Date:.....May 5th
Ad placement: Entertainment Section

Summer camps are easy to find.

(when you know where to look)

The Observer & Eccentric Newspapers
CAMP CORNER

All deadlines for the Camp Corner will be on Friday before the Thursday Edition

Look for this corner to appear in the Sports Section every Thursday until July 18th!



CHILD CARE DIRECTORY

Does your Child Care Business have programs and activities that will help nurture a child's imagination? If so, The Observer & Eccentric Newspapers is a great place to advertise your business!

With a 1/4 million moms and dads reading the paper each week in Wayne and Oakland Counties, your business will have the opportunity to show them why they should trust you with their prize possession!

First Deadline: Thursday, May 9th
First Run Date: Thursday, May 16th
This directory will run until June 30th. All deadlines are on Monday for that Sunday's edition.

For more information call: **Dylan Bawuleki** 734 953-2073

PROM DIRECTORY

This is your opportunity to help these kids prepare for one of the biggest nights of their life! Don't let that business on the corner take away from your chance to grab their attention on what you have to offer.

The first ever "Prom Directory" will appear in all 16 papers in Wayne & Oakland Counties. You know what your business has to offer, so why shouldn't they? You never know, you could win them over and have them come back for an even more important day - their wedding.

The deadline for this directory is on Fridays and you can look for it to appear in the Entertainment/Travel Section. Total Run: Every Thursday from April 11th through May 30th.

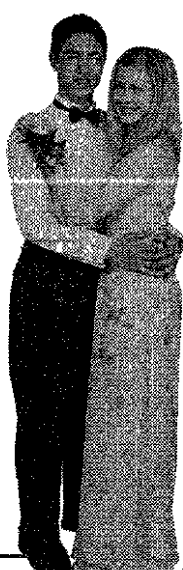

FOR MORE INFORMATION - CALL: **DYLAN** (734) 953-2073 FAX: (734) 953-2232

Look for information on these directories in May:

HEALTH & FITNESS DIRECTORY

PET DIRECTORY

Special Golf Directory for the Spring of 2002

What a great place to advertise your golf related business.

This special directory will allow you to reach 400,000 Observer & Eccentric customers. Look for this tab to be running throughout the spring summer and fall on Thursdays.

THE Observer & Eccentric NEWSPAPERS

36251 Schoolcraft Road • Livonia, MI 48150

- Livonia Observer
- Canton Observer
- Plymouth Observer
- Westland Observer
- Garden City Observer
- Redford Observer
- W. Bloomfield Eccentric
- Farmington Observer
- Southfield Eccentric
- Rochester Eccentric
- Birmingham Eccentric
- Troy Eccentric
- Clarkston Eccentric
- Oxford Eccentric
- Lake Orion Eccentric
- Waterford Eccentric



All deadlines for the Special Golf Directory are on the Friday before the upcoming Thursday edition.

SAMPLE SIZES AND PRICES

2 columns x 2 inches (approx. 4 1/4" x 2")

YOUR COST:

1 column x 2 inches (approx. 2" x 2")

YOUR COST: \$80.00 Per Insertion

OPEN RATE: \$215.60

* 3 column x 3 inch size available in The Camp Corner.

YOUR COST:

2 columns x 3 inches (approx. 4 1/4" x 3")

OPEN RATE: \$646.80

\$240.00 Per Insertion

DINING OUT

Authentic MEXICAN CUISINE lies north of the border

BY RENEE SKOGLUND
STAFF WRITER
rskoglund@oe homecomm net

True or false? You have to travel to the Southwest for authentic Mexican cuisine. Definitely false, compadre, especially when it comes to Camelia's Authentic Mexican Cuisine in Farmington Hills.

"We are actually more Tex Mex," said owner Camelia Flores. "The reason we say 'authentic Mexican' is because all of our foods are made from scratch."

Mexican or Tex Mex, the food at Camelia's is authentically delicious. The taco shells are parchment-paper crisp, the rice flavorful, and the refried beans taste nothing like the mush you get in cans. They're wonderfully "beany" with a savory bacon flavor. Need to know more? The salsa, which is made every morning and allowed to blend several hours in refrigerator, is chock-full of fresh cilantro.

"People have asked me if I would jar the salsa and sell it in a market. I think I'd have to put vinegar in it to preserve it, and I don't want to do that," said Flores.

Some people judge a Mexican restaurant by its tortilla chips. Camelia's homemade chips rate high.

"We always made them at home," said Flores. "I said I'm going to try these here. Now I couldn't go back. People love them. We have one person back in the kitchen deep frying all day."

Opened just eight months, Camelia's is a family affair, with everyone involved - husband Tony, son Greg, and Flores mother, Dominga Garcia, who taught Flores how to cook.

"Now I'm teaching my granddaughters how to cook," said Garcia. "I learned from another Dominga, my father's mother. She was born in Mexico."

Menu

Camelia's is small and com-

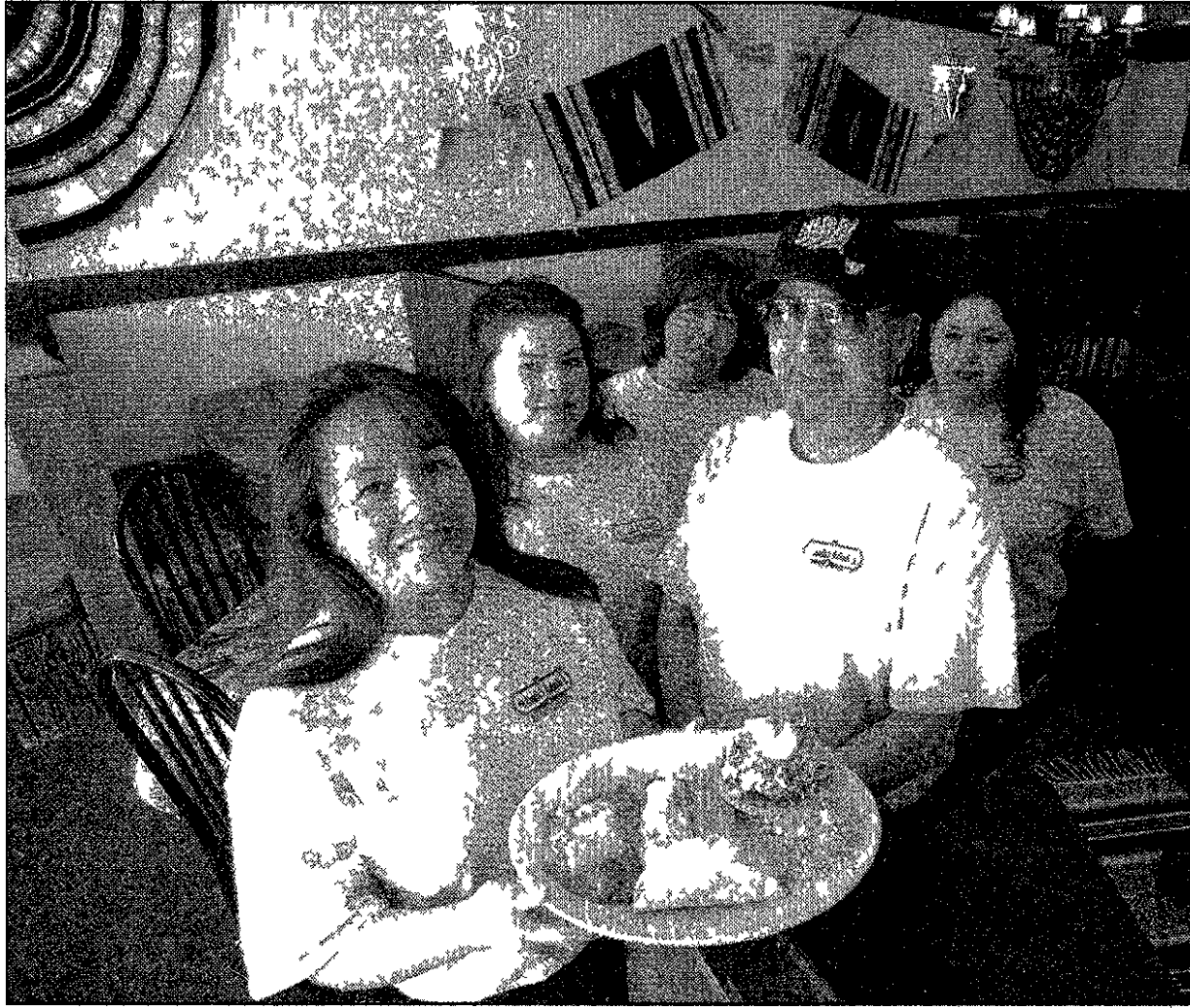

Family and friends: Camelia's staff includes Camelia and Tony Flores, Maria Flores, Lisa Perez, and Rosemary Tuttle

fortable and the large front window lets in lots of sunshine. Colorful ponchos and paintings add just enough accent to the off-white walls. However, it's difficult to miss the huge framed photograph of Flores' father in the entranceway. There, in all his glory, is 17-year-old Jesus Garcia fighting a bull. Besides being a matador, Jesus was a cliff diver in Acapulco.

"He was very brave," said Flores. Quite an understatement.

While you don't have to be brave to eat at Camelia's, the

salsa is not for timid taste buds. Otherwise, order all the tacos, burritos and enchiladas you want and rest assured your heart burn will remain south of the border.

"I always tell people who come here for the first time to get the combination plate for variety," said Flores. "But my favorite is the Enchilada Suizas or the Camarones Rancheros. That's whole shrimp, and they're pretty good size, in our homemade ranchero sauce."

Flores' son, Greg, who plays in

a Mexican band and can sometimes be heard singing from the kitchen, recommends the Milanesa Dinner - steak or chicken breaded in special Mexican seasonings and topped with melted cheese and avocado. But then, everything tastes good at Camelia's, he said.

I took Flores' advice and ordered the combination plate - one flauta, chalupa and quesadilla with lots of rice and refried beans. Delicious. My dining companion ordered the taco salad. She loved the shredded



Olé: Camelia's combination plate is a favorite. One taco, tostada, enchilada and tamale along with homemade refried beans and quacamole. The salsa, chips and tortillas also are homemade.

Camelia's Authentic Mexican Cuisine

Where: 30701 West 12 Mile Road (in the Regency Plaza just east of Orchard Lake), Farmington Hills (248) 474-0902

Atmosphere: Small (seats 75), uncluttered, pleasant

Menu: Appetizers, salads, dinners and daily specials. Average dinner prices \$7.50-\$11. Lunch specials \$5.99

Hours: 11 a.m. to 9 p.m. Monday-Thursday; 11 a.m. to 10 p.m. Friday; noon to 10 p.m. Saturday; 1 p.m. to 8 p.m. Sunday

Extras: No smoking, take-out, catering and lots of friendliness

chicken and claimed the taco shell bowl definitely was not the hard, flower-pot variety served in other Mexican restaurants.

"And the cheese is white," she exclaimed. "When you go to Mexico there is no orange cheese."

Catering

Flores doesn't do large-scale catering, but she does make up "fiesta trays." Each tray contains 100 items - 20 each of tamales, hard tacos, soft tacos, enchiladas and burritos. The trays, which also come with rice, beans, four large bags of chips and two large containers of

sales, cost \$250.

"It's a real hot seller for baby showers and graduations," said Flores.

Flores hopes lots of people visit Camelia's on Sunday, May 5, in honor of Cinco de Mayo, which celebrates Mexico's victory over the French during the Battle of Puebla in 1862. She plans to have live entertainment, special give-aways, virgin Margaritas and daiquiris (they have no liquor license), as well as run specials on steak fajitas.

But don't wait until May 5 to visit Camelia's. Stop by anytime. A bowl of tortilla chips and salsa will be waiting.

STAFF PHOTOS BY BILL BRESLER

Observer Classifieds sell! Call 800-579-SELL today!

GREATER REDUCTIONS JUST TAKEN ON OUR ENTIRE FINE JEWELRY & WATCH COLLECTION

Now Save! **30-60%** off original ticketed price

Plus **4 DAYS ONLY!** THURS. - SUN. April 25th - 28th

RECEIVE AN **EXTRA 15%** off THE SALE PRICE

Select From World Famous Designer and Brand Names: Scott Kay, Harry Winston, Pasquale Bruni, Ambar, Chaumet, Quadrillion, Charles Kruppell, Boucheron, Bertolucci & Others!

DIAMONDS - GEMSTONES - GOLD - WATCHES - GIFTWARE

The Quality and Style You've Always Desired at Prices You Could Only Dream Of

MAYORS™

PREMIER JEWELERS SINCE 1910
SOMERSET COLLECTION S
2861 W. BIG BEAVER RD. TROY

QUANTITIES MAY BE LIMITED

NOT ALL DESIGNERS AVAILABLE AT ALL LOCATIONS.

MOST MAJOR CREDIT CARDS ACCEPTED. ALL SALES FINAL.

NOW OPEN



**Laurel Park Place
Livonia**

37546 West Six Mile Road
Parisian Wing, Across from Eddie Bauer
734.591.0476
www.cpk.com

To Celebrate Our Grand Opening at Laurel Park Place, on Monday, April 29, CPK will donate 100% of pizza sales to support the Make-A-Wish Foundation of Michigan.

Pizza • Pasta • Salads • Desserts

Bridge to the world

Ramp program is blessing for those with disabilities

Five years ago, Rosie Hutchinson's family planted spring flowers in front of her home. She didn't go out to see them. Four years ago, they planted spring flowers. She didn't go out to see them. Three years ago, two years ago. And last year. This year, Hutchinson will go out to see the new flowers. This year, she's determined to help plant them.

This year, you see, for the first time since illness and disabilities locked her into a wheelchair, the 63-year-old grandma will roll past the barricading front steps that had barred flowers, fresh air, roller-skating grandchildren, and waves to new neighbors.

This spring, Hutchinson's chair, rather than continuing to confine her, will glide down the ramp just built at her front door. It will take her into a world she hasn't seen all these years.

She'll see the front of her house the same color as five years ago, but probably in need of painting, she said.

She'll see families who have moved in, she'll see the sidewalk where the kids play, and she'll see the flower beds filled in times past with plants she could only enjoy in photos the family brought in for her.

"I missed a whole lot," said the long-divorced mother of five and grandma of 16.

Her first time out, helped only as far as the head of the new ramp by one of her granddaughters, the world opened to her. "Oh, I loved it. I smelled the fresh air."

Soon, she'll make the ride down the ramp. One goal. The flower beds.

"With their help, I can just bend down and plant."

'Overwhelming need'

With the freedom the ramp promises, Hutchinson recognizes responsibility, as well, especially for the safety of the children who constantly visit. She's told them, "No roller skates on my ramp. They can walk down, but no skates, no bikes. They started to, but I stopped them."

Hutchinson, of Pontiac, had been stopped from going to church, at New Springfield Baptist, and is eager to rejoin her friends there. For anyone wondering how she got to

Please see **RAMPs**, C2



Rosie Hutchinson gets a little help from her granddaughter Bianca Ross down her new wheelchair ramp built by Oakland Livingston Human Service Agency

By Norman Prady ♦ Special Writer

File mail right away in designated 'homes'

Q: I do not know how to efficiently deal with all the mail we receive each day. I never know where to put everything, so it usually ends up stacked on the kitchen counter.



Diana Koenig

A it will be easier to deal with the mail if you create a home for each paper before it enters your house. Anticipate the kind of mail you receive and create a place for these papers ahead of time. Some mail you will not be able to foresee, so you will need to make a file for these items after they arrive at your house.

If you receive an abundance of unwanted mail then call or write organizations and ask for your name to be deleted from their mailing list.

Homes for the Mail

Bills - Make sure there is a specific home for the bills, such as a specific box labeled 'bill box' or file folder. The location should be in a place that you would look at often so you remember to pay the bills on time.

Spouse's mail - Assign a basket for your spouse's mail. Ask him to deal with it immediately or before the basket overflows.

Children's mail - Place their mail in their room on a desk, dresser, or designated basket.

Junk mail - Immediately place these papers in the trash

Coupons - Store this information in a labeled file folder. When it is time to do your taxes, you will not have to hunt for the necessary papers because you will have them organized in one folder.

Invitations - Write the date on your calendar and then place the invitation on the refrigerator, file folder, or accessible drawer. After the event either discard or file the invitation so you do not clutter your refrigerator or drawer with unnecessary information.

Cards, letters, announcements - Designate a keepsake box for items you want to save. You may choose to save some of these memorabilia for only a few days.

Charitable organizations - Create a folder to keep information from an organization you would like to support. If you do not plan to contribute a donation, discard the letter.

Tax information - Store this

information in a labeled file folder. When it is time to do your taxes, you will not have to hunt for the necessary papers because you will have them organized in one folder.

Invitations - Write the date on your calendar and then place the invitation on the refrigerator, file folder, or accessible drawer. After the event either discard or file the invitation so you do not clutter your refrigerator or drawer with unnecessary information.

Cards, letters, announcements - Designate a keepsake box for items you want to save. You may choose to save some of these memorabilia for only a few days.

Voter cards - This is your reminder to vote. Put it in a visible place until after the election.

Catalogues - Only save the

catalogs you intend to order products from. Put them in a container or file folder. Discard the old catalog when you receive a new one.

It is important to deal with the mail immediately when you bring it into your house. Piles of homeless papers are an overwhelming task to deal with. If you have been on vacation, you will need to designate extra time to sort through the stacks of mail.

Today's Refrigerator Bulletin: "Avoid a paper trail by immediately finding a home for each piece of mail!"

Diana Koenig is a writer, educator, speaker and consultant. Send your questions and success stories to Diana Koenig, PO Box 1702, Manchester, Mo. 63011, e-mail duanakoeng@hotmail.com. Visit www.domesticplanner.com.

APPLIANCE DOCTOR

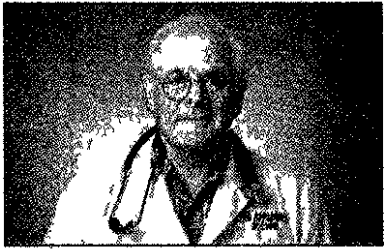

JOE GAGNON

'Smart' fridge checks prices, gets recipes, tips

There's been a lot of attention focused on home appliances of the future. Predictions of how appliances will work, and do things differently than they do today, are at the point of being a little silly.

I remember back in 1975 when a manufacturer predicted that microwave ovens would be used for telecommunications, and as a cooking appliance. Most of us are still using the microwave the same way we were back then. Like many of you, I read the recent story about the refrigerator that will turn into a kitchen range at the flick of a switch. It makes me wonder where they are going to store ice cream in this unit. It's hard for this white haired old man to accept these new concepts but I must admit they are coming true.

Smart refrigerator

Take the case of a producer of refrigerators from Seoul, Korea who has introduced the product of tomorrow. Let me quote a piece from a trade publication called *Professional Service Association News*.

"The manufacturer has pioneered and continues to lead the industry in developing cutting-edge digital home appliances. Their vision is to create appliances that go beyond a simple mechanical function like heating food or keeping it cold. Instead these next generation appliances will perform greater tasks, such as collecting recipes, preparing meals and keeping pantries stocked - tasks that require intelligence. They will be interconnected via the Internet and work together to become our assistant homemakers."

Now folks, I don't want anyone to think this column is an April fool's joke because this refrigerator is already set for distribution and purchase by the end of the year. I mean you will be able to buy one for your home by the end of 2002. Imagine, a 26-cubic-foot refrigerator that can check real-time price information on groceries, obtain tips on food, nutrition and recipes, be reminded of scheduled events, when to change the water filter and learn cooking methods for products stored inside.

Consumers will be able to use this new Internet-connected refrigerator as a television, radio, videophone, bulletin board, calendar and digital camera. I personally find it hard to believe all that I am writing today but you can count on it being true.

Healthy suggestion

If I were able to make a suggestion to this company, I would ask them to put a spot on the front door a person can stick their finger into to get an instant read-out on blood pressure and pulse. That feature would save a few lives and prevent strokes. I keep telling myself as I'm writing, "don't say anything Joe, keep your dry sense of humor to yourself."

Think about it folks - new technology can change so many things. A home will cost a lot less in the future. You will have three bedrooms and one gigantic room called a kitchen and forget the rest. Will this country go for this new refrigerator is the big question, and only time will take care of the answer. I'll let you know just as soon as I find out how much this refrigerator is going to cost. That could have a bearing on its success. Stay tuned.

Joe Gagnon can be heard Saturday and Sunday on 760 WJR. He is a member and past president of the Society of Consumer Affairs Professionals. His phone number is (313) 873-9789.

Ramps from page C1

the doctor all this time, she explains that she's fortunate to have a doctor who makes housecalls

And now that she's reclaimed her right to outdoors, Hutchinson dreams of a van with a chairlift "Maybe God will hear my prayer," she said

It was a local social organization that heard her prayer for a way out of her house Oakland Livingston Human Service Agency, headquartered in Pontiac and serving throughout the two counties, included Hutchinson's home in its pilot program of five ramps

Jerry Sedick, OLHSA's associate director, said the need for this service is "overwhelming" The agency built its first ramp last December using grants from the United Way of Oakland County and the Area on Aging

As much as OLHSA needs funds, Sedick said, it needs volunteers to do the construction work Willingness, he said, can be more important than skill While it takes about a week or so to do the job, he said, volunteers who can give any amount of time are vital to the program's operation

Volunteers can contact Sedick at (248) 209-2650

Commercial sources

There also are commercial sources for residential wheelchair ramps Among them are Wright & Filippis, Inc., of Rochester Hills, and Caring Solu-

tions, of Farmington Hills

A J Filippis, CEO of his company, said cost of an average ramp without complicated turns is about \$3-4,000 His company generally uses treated wood for permanent installations Temporary ramps are priced at a fixed fee for installation and removal and a minimum of three-months rental, totaling about \$1,700 \$2,200

Filippis points out that city building permits are required and various state regulations must be followed Do-it-yourselfers ought to know that every inch of rise necessitates 12 inches of ramp, every 30 feet of ramp require a resting platform Railing spindles must be on a maximum of 4 inch centers to prevent child head entrapment

At Caring Solutions, executive assistant Janet Parker said her company likes to build the ramp at the rear of the house whenever possible, for appearance and security When the ramp must be at the front of the house, "We try to integrate landscaping to reduce the harshness of the appearance" She said her company even has built ramps inside attached garages Her company's average ramps, she said, can be in the \$2-5,000 range

Both companies say that under certain conditions, some insurance plans can help with the cost of the ramp

Marketplace

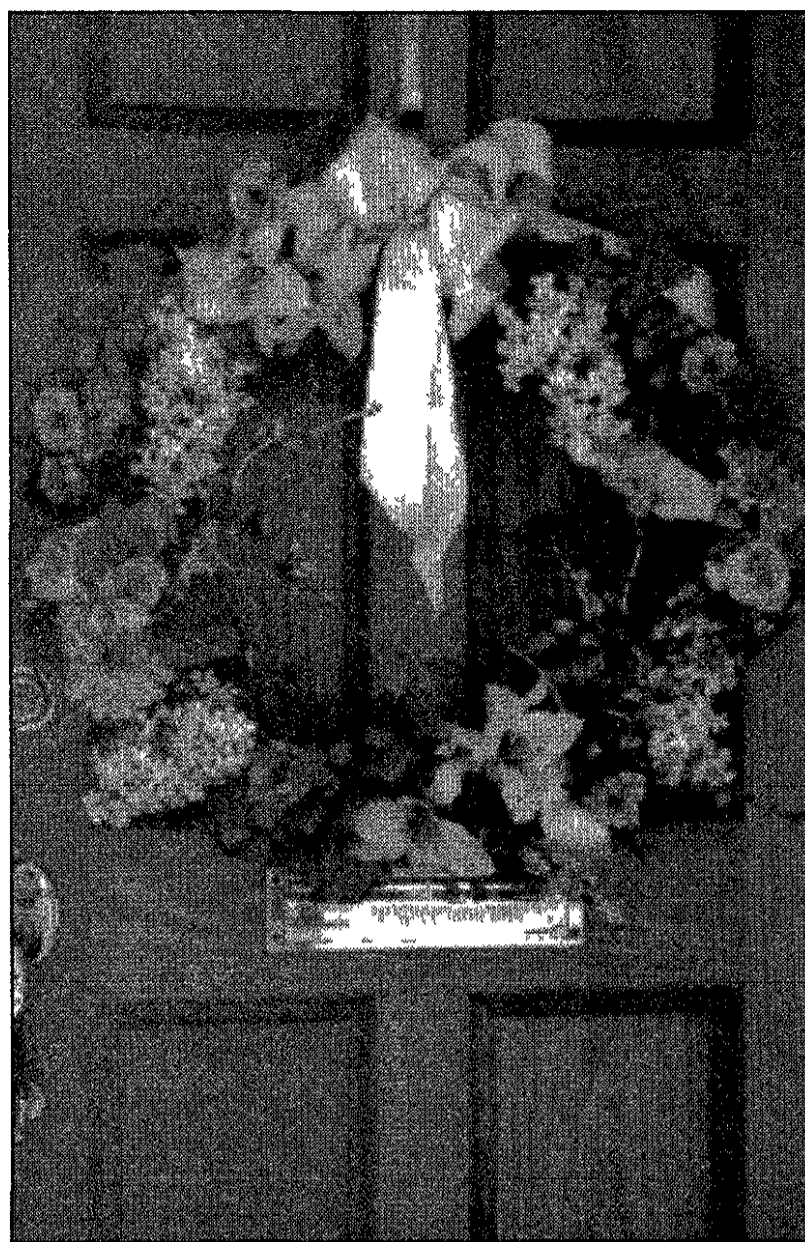

Spring wreath: This one-of-a-kind door wreath announces spring with its paper and fabric daisies, lilacs and lilies all highlighted by a big ribbon. The custom wreaths are available at Artistic Expressions, Custom Florals by Patricia, in Birmingham. Prices depend on customer's requirements and flowers used This one is \$145 For more information, call (248)644-8439. Marketplace spotlights items available at retail stores in the Observer & Eccentric coverage areas. To submit an item for consideration, send a photo of it to "Marketplace," 805 East Maple Road, Birmingham 48009. Please include a contact phone number



Yard Art...

2 Acres worth!

Unbelievable selection of:
Fountains, Planters,
Statues and Bird Baths

10% off

ONE WEEK ONLY!

April 25th- May 4th

ROCK SHOPPE
Landscape Supply
PLYMOUTH, MI

N Territorial • W of Gotfredson Road • Plymouth

734-455-5560

You'll Appreciate Our **Leather** Prices



Open Daily 9:30-6
Thurs & Fri til 9 p.m.
Sat 9:30-5:30



Flexsteel.
America's Seating Specialist

as much as you love our Flexsteel Furniture

We have received a special volume purchase discount from Flexsteel and we're passing the savings on to you

The luxurious softness of leather combined with the legendary strength of Flexsteel's lifetime construction now at a price that's positively irresistible

Leather Sofas starting at \$1299⁸⁸

Laurel FURNITURE, INC.
584 W ANN ARBOR TRAIL • PLYMOUTH • (734) 453-4700

FLEXSTEEL FINE FURNITURE BEGINS ON THE INSIDE



Slow-Release Fertilizer

- Good for the Grass
- Good for Rivers and Lakes
- Good for Groundwater

Rouge River Watershed • Ours to Protect

This advertisement is funded in part by the Wayne County Rouge River National Wet Weather Demonstration Project For more information, please call the Wayne County Department of Environment at 888.223.2363 or see our website at www.waynecounty.com



Blue Dot.
Service by KAST
Cherry Hill Bergstroms

FLAT RATE PRICING
24/7 EMERGENCY SERVICE
ONE YEAR GUARANTEE on all Service Parts & Labor
Trust Certified Technicians for Your Protection

DON'T PANIC!
You'll know what your repair will cost BEFORE we start the job.

WE REPAIR, SELL & INSTALL:

- ✓ Furnaces & Air Conditioners
- ✓ Plumbing & Power Humidifiers
- ✓ Hot Water & Steam Boilers
- ✓ Air Cleaners & Duct Cleaning

\$500 OFF Premium Furnace and A/C Unit

Limit one coupon per customer. Not valid with any other offer. Offer expires 5/31/02.

1-800-BLUE-DOT

\$20 OFF Clean 'n Check or any A/C Service

Limit one coupon per customer. Not valid with any other offer. Offer expires 5/31/02.

1-800-BLUE-DOT

\$20 OFF Any Service Call

Limit one coupon per customer. Not valid with any other offer. Offer expires 5/31/02.

1-800-BLUE-DOT

\$12 MONTHS • No Interest • No Payments

Limit one coupon per customer. Not valid with any other offer. Offer expires 5/31/02.

1-800-BLUE-DOT

Blue Dot.
Service by KAST • Bergstrom's • Cherry Hill

Proud Supplier of **bryant** Heating & Cooling Systems

1-800-BLUE-DOT
1-800-254-3368

Spring Sale

The Month of May

10% off

All Granite in stock

Granite 3cm thick!

\$45.95	S/F	Rosa Beta
\$45.95	S/F	Luna Pearl
\$45.95	S/F	Desert Gold
\$49.95	S/F	Tan Brown
\$49.95	S/F	Impala Black
\$49.95	S/F	Verde Butterfly
\$52.95	S/F	Absolute Black

All prices include installation & measurement, straight polished edge 20 s/f minimum

Marble - Granite - Silestone®

Why buy countertops at retail when you can buy direct Since we fabricate at our own locations, we beat the "Big Box" store pricing. We offer quick delivery and personalized service.



CERAMIC TILE INVENTORY BLOW-OUT SALE!

10% off List with this ad. Sale excluded.

Silestone® 3cm thick!

FINAL CLOSE-OUT

\$34.95 s/f installed!
includes straight polished edge 20 s/f minimum

We stock over fifteen hundred slabs of Marble, Granite and Silestone in over eighty unique colors. We stock the largest selection of imported ceramic tile in Michigan.

Ceramic Tile Sales Inc. Marble & Granite Shop

Southfield 23455 Telegraph Rd 248-356-6430	Farmington Hills 24301 Indoplex Circle (248) 426-0093	Rochester 1972 Star Batt Dr 248-853-4654
--	---	--

Visit one of our Showrooms!

Installation includes Wayne, Oakland and Macomb Counties. Others at additional cost. Offer not valid with any other discount. All previous orders excluded. Subject to stock on hand.

Showroom Hours: M-T-Th 8:30-5:00; W-F 8:30-8:00; Sat 9:00-5:00

Books bring ideas for backyard to forefront

Many people are staying closer to home now and consequently many are gardening. Here are some books that should help all gardeners achieve their goals.

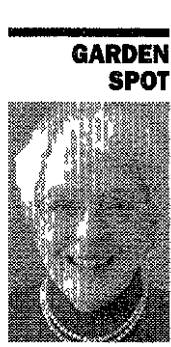

MARTY FIGLEY

The book gives steps necessary to create a user friendly backyard, beginning with a simple design process the reader can follow.

All aspects are covered such as composting, utility areas, water (use a rain barrel) lawns, fertilizers, pruning, tools, hardscapes and plant selection. Organic approaches to pest and weed control are also included. I predict this book will be one that is used extensively.

Annuals, perennials

Two other new books will, I predict, also be used on a regular basis. Nancy Szerlag, columnist for *The Detroit News*, and horticulturist Alison Beck have written two books especially for our gardens. They are *Annuals for Michigan* and *Perennials for Michigan* (Lone Pine Publishing,

\$18.95 each).

Both books follow the same format, beginning with a general overview of the plants, proper soil conditions, composting, seedling and planting instructions, and more. Annuals (443 of them) and perennials (681) are described and photographed beautifully.

The authors feature height and spread ranges, flower color as well as bloom times and hardiness zones for each, plus growing tips, recommended hybrids, and pest and disease problems.

The information is clearly written, direct and to the point. Both books include quick reference charts that really save time. The soft, waterproof covers will resist damage so you won't hesitate to take them to the garden.

Another offering from Taylor's Guides series is *Ground Covers*, Nan Sinton and David C. Michener (Houghton Mifflin, \$23). This book profiles many of these versatile plants.

Practical information about new cultivars and many old favorites will open a new world of ideas for the gardener. The encyclopedic section describes more than 4,000 plants with growing tips and how to use them in the landscape, suitable companion plants and how the plants got their names. Plants are listed with botanical names, pronunciation guides and the families to which they belong.

Herbs, art

Herbs, Lesley Bremness (a

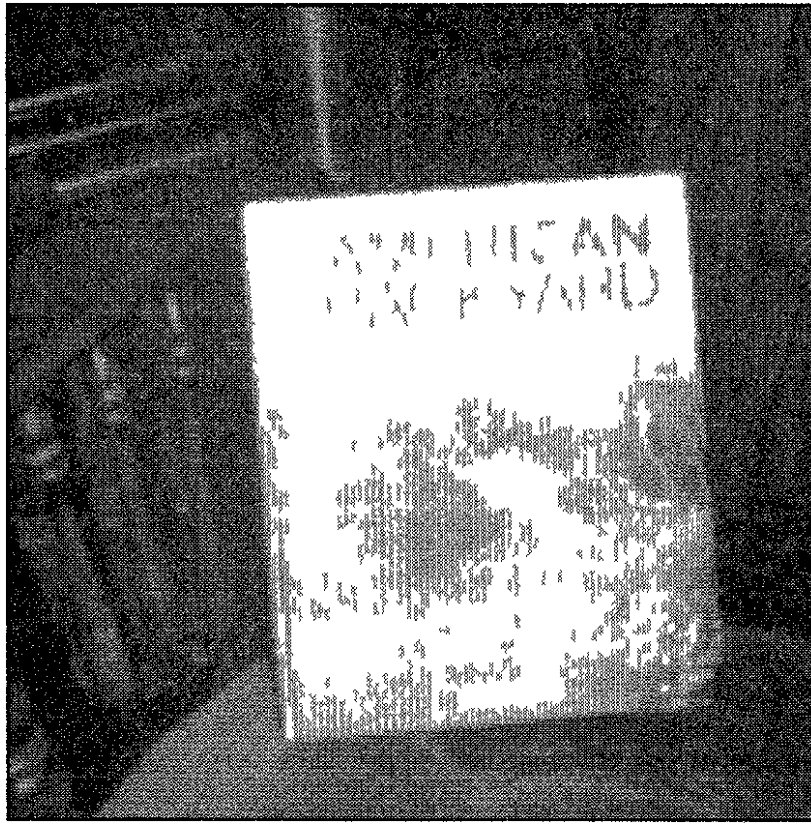

MARTY FIGLEY

Beckoning back yard: This book will help you create a user-friendly back yard.

Dorling Kindersley handbook \$18.95 fully illustrates more than 700 species.

All parts of each plant, tree,

shrub, herbaceous perennial, annual and biennial and other herbs are clearly photographed.

This makes identification quite

easy. The book is full of information and Bremness explains how herbs have been used in cooking, as medicinals, in cosmetics and grown in herb gardens.

The first American edition was published in 1994, this edition was reprinted with corrections in 2000, the editorial consultant was Holly H. Shumizu.

Native Trees, Shrubs and Vines: A Guide to Using, Growing and Propagating North American Woody Plants, William Cullina (Houghton Mifflin, \$40), has a publication date of June 12, 2002.

This has excellent advice for any wildflower enthusiast. Cullina is the nursery manager and propagator at the Garden in the Woods of the New England Wild Flower Society.

"For the purpose of this work, 'native' means plants growing in North America prior to European settlement, and the term 'woody plant' means any species with at least a woody trunk or base," he writes.

Also featured are instructions on how to attract specific species of birds and butterflies to supply food and shelter and how to restore habitats by using land type-specific woody plants, and where to find the right "native" for a garden. Look for this win-

ner soon.

Painting Flowers in Watercolor: A Naturalistic Approach, Coral G. Guest (Timber Press \$19.95), is a treasure of beautiful art work using "a modern style of flower painting."

Guest's aim is to capture the spirit and luminescence of the flower while still being botanically correct. She has organized her techniques so that an artist of any skill can follow the instructions and has included practical advice, such as materials, equipment and ideas of where to find subject material.

The book is published in association with The Royal Botanic Gardens, Kew.

GOOD GARDEN TIP

Branch Tree Service Inc. of Warren and Royal Oak has alerted us that the deadly disease, Ash Yellow, is making inroads in destroying our ash trees. Usually found in white ash, it has also been found in green ash. Have your trees inspected by a qualified arborist now.

Marty Figley is an advanced master gardener based in Birmingham. You can leave her a message by dialing (734) 953-2047 on a touch tone phone. Her fax number is (248) 644-1314.

Hurry...10 DAYS ONLY!
Storewide Spring Sale
40%-60% off Mfg. List Price
All Polished Brass Outdoor Lanterns
Buy 1, Get 1..... FREE*
*of equal or lesser value. In stock only.
MASTER LIGHTING INC.
44125 Ford Road • Canton
734-981-3666
Hours: Mon-Wed & Fri 10-6, Thurs 10-8, Sat 10-5 Sun 12-4

FURNITURE, JEWELRY, VINTAGE CLOTHING, RADIOS & TV'S, PHOTOGRAPHS, ART GLASS, CHINA, SILVER, BRONZES, CLOCKS, WATCHES, ARCHITECTURAL PAINTINGS, PRINT ART, POSTER ART, TEXTILES, LAMPS, AND BY FAR THE MOST WONDERFUL ASSORTMENT OF FURNISHINGS, OBJECTS AND RETRO MEMORABILIA TO BE FOUND ANYWHERE ON THIS PLANET... ALL FOR SALE!
ABSOLUTELY FANTASTIC!
THE MICHIGAN MODERNISM EXPOSITION
ART DECO ART NOUVEAU ARTS & CRAFTS STREAMLINE PRAIRIE SCHOOL ART MODERNE INDUSTRIAL DESIGN FOLK ART FIFTIES SIXTIES AND MUCH MORE!
April 27th and 28th
Saturday 11 until 9, Sunday 12 until 5, Admission \$8.00
Gala Preview April 26th
7 pm til 10 pm to benefit MoNA - The Museum of New Art
On Evergreen Road @ 10 1/2 Mile (exit Evergreen south from I-96)
SOUTHFIELD CIVIC CENTER
\$1.00 OFF GENERAL SHOW ADMISSION with this ad (single admission only)
www.artinnet.com/MAM

VALUE CARPET
Hurry Last Week!
FREE Removal of your Old Carpet
FREE One Year No Interest No Payment
FREE 8 lb. Pad
We'll match the competition plus take an additional 10% off
Carpet • Ceramic Tile • Vinyl Flooring • Laminate Flooring • Hardwood Flooring
LIVONIA 33555 Seven Mile (248) 442-9707
DETROIT (313) 372-6692
HAZEL PARK (248) 546-4419
Hours: Monday - Saturday 10am - 7pm
Offer expires 4/31/02
Coming Soon...Value Carpet Southgate!

IT'S OUR... Spring Fling 4 Days Only!
SALE... FRI., SAT., SUN., & MON. April 26, 27, 28 & 29
40% OFF EVERYTHING IN THE STORE!*
AND...
MAKE YOUR PURCHASE \$3,500 OR MORE AND CLASSIC INTERIORS WILL... PAY YOUR 6% SALES TAX!
CLASSIC INTERIORS FURNITURE
VISIT OUR IN-STORE CLEARANCE CENTER
20292 MIDDLEBELT • LIVONIA • SOUTH OF 8 MILE
OPEN MON., THURS., FRI. 9:30-9; TUES., WED., SAT. 9:30-5:30; SUN. 1-5
(248) 474-6900
*SELECTED THOMASVILLE PIECES MAY NOT BE AVAILABLE AT THE 40% DISCOUNT. SEE YOUR SALES PERSON FOR DETAILS.

It's been a long time between rides

BY RENÉE SKOGLUND
STAFF WRITER
rskoglund@oe.homecomm.net

Do it No, don't do it Oh, do it But you have bones like Swiss cheese So what, do it You're too old to be biker babe Who says? Last Saturday St. Kenneth Catholic Church in Plymouth held a Blessing of the Bikes ceremony My friends, Dan and Kerri Sarb, who own Harvey's Old Village Deli in Plymouth, organized the event After the blessing, Dan asked me if I wanted a ride on his Harley Dina-Superglide Thus began the internal conversation that opened this column

I felt like the Shakespearean version of a wannabe Hells Angelette To ride or not to ride I rode And let me tell you, there's nothing like wind in your face and two fast wheels under your butt on a glorious Saturday afternoon

"There's a old Harley saying," said Dan, as we rounded out of St. Kenneth's driveway "If you have to ask what's so great about a riding a Harley, then you don't understand" He's right

The sky was blue and the trees were green when I drove to St. Kenneth's, but were they really that blue and that green? How come I never noticed that patch of flowers before? And why did downtown Plymouth seem so much more "alive?"

I was having a Harley epiphany It had been a more than dozen years since I rode on the back of a motorcycle That ride came compliments of my husband Gary's small-town, big-hearted, truck-driving cousin, Jay Peteler, while we were vacationing in Alexandria, Minn My husband was born in Minnesota, and every summer the Skoglund and Schneider clans rented cottages in Alexandria for a week

Picture this For one week the men folk fished, played horseshoes and euchre, stared out at the lake and waited for the women folk to make the evening meal, usually a collage of casseroles, or in Minnesota lingo, "hot dishes" The older women folk sat under shade trees exchanging "news" until they had to prepare the hot dishes The younger women were usually out on a raft in the middle of the lake with a couple of six packs The kids were everywhere

Then one evening, Jay throttled in on his big Harley "Hey, Renee, wanna goffer a ride?"

Please see **MOTORCYCLES, C6**



STAFF PHOTO BY TOM HAWLEY

Chin up: I buckle up in anticipation of my motorcycle ride

WALKING THE TALK

women make strides in Avon Breast Cancer 3-Day

BY RENÉE SKOGLUND
STAFF WRITER
rskoglund@oe.homecomm.net

Rain or shine, area participants in the Avon Breast Cancer 3-Day have stuck to their training schedules They know the walk - a 60-mile, three day trek from Ann Arbor to Detroit from May 31 to June 2 - is for the tough and the determined

Noreen Loper of Livonia has been walking 15 miles several times a week through Hines Park with her daughter, Debbie Pluff, who also signed up for the Avon 3 Day

"When my daughter said I had to walk, I said, 'Are you out of your mind? Do you know how old I am?'" said Loper, who is 69

Like many other participants, Loper has a story She is a breast cancer survivor When her breast cancer was detected by a mammogram in December 2000, she was totally surprised The lump had not been palpable, and there was no breast cancer in her family

"At the time I said, 'Where in the world did this come from?'"

Loper underwent an initial lumpectomy then additional surgery after her cancer was diagnosed as invasive ductal Twice-daily bouts of internal beam radiation for 10 days at Beaumont Hospital followed

Loper is now cancer free She is walking out of gratitude

"The good Lord brought me through this This is how I can give back," she said

Linda Taub, 52, a nurse from Garden City, also is walking because she is thankful

"I'm walking partly for a personal challenge and in gratitude that my family is not afflicted by this"

Taub, who has a hefty sense of humor described herself as a "fat little middle age woman when first interviewed in January By the end of March she had lost 28 pounds, and she



STAFF PHOTOS BY TOM HAWLEY

Challenge: Linda Taub, a nurse from Garden City, is walking 60 miles during the Avon Breast Cancer 3 Day because she is grateful that her family and friends have not had the disease. She also said the walk was a "personal challenge"

recently started walking to work - a 15 mile journey

Linda said her son Scott 29, has been her biggest supporter He donated \$1 000 of his Christmas money to fund

his mother's walk Each walker must raise a minimum pledge of \$1 900

"I think it's great," said Scott "She's been working at training for several months"

Walking may be the easiest part of the 3-Day for Taub As an ex-homecoming queen (Garden City West 1968), she plans to wave to the crowd of well-wishes along the route She'll need a strong pair of wrists

"I still teach parade-waving 101," she joked "I show

the girls how to wave from a floats first your left hand and then your right hand

In memory of mothers

Carleigh Flaharty, 29, president of the Farmington/Farmington Hills Chamber of Commerce, made the commitment to walk in the Avon 3-Day last September in honor of her mother, Lana Barnes, a four-year cancer survivor

"To me, it just seemed natural, something I should do for my mom," she said

Flaharty's participation in the walk seems all the more significant since she is battling cancer herself She was diagnosed in December with Hodgkin's lymphoma

"As long as I have the energy, I will participate It's given me something to focus on during my treatment I looked at the way my mother did her battle, and I modeled the way I handle my own treatment after her"

Suzy Preman, 26, works as a dental hygienist in Canton Last Sunday, friends of hers who have a band, the Rusty Lunch Box, played a benefit concert at Boulders restaurant in Plymouth to help raise money for Preman's walk The owner of Boulders also agreed to charge a donor fee for the concert and donate it to Preman

Such generosity motivates Preman, who has walked in the Karamanos Race for the Cure, to continue doing



Her mother's daughter: Carleigh Flaharty, president of the Farmington/Farmington Hills Chamber of Commerce, is walking the Avon 3-Day in honor of her mother, a cancer survivor.

her part in the battle against the disease that affects one in eight women Preman's mother died from breast cancer three years ago this August

"I'm walking just to spread the word about prevention so the women will get

Please see **WALKING, C7**

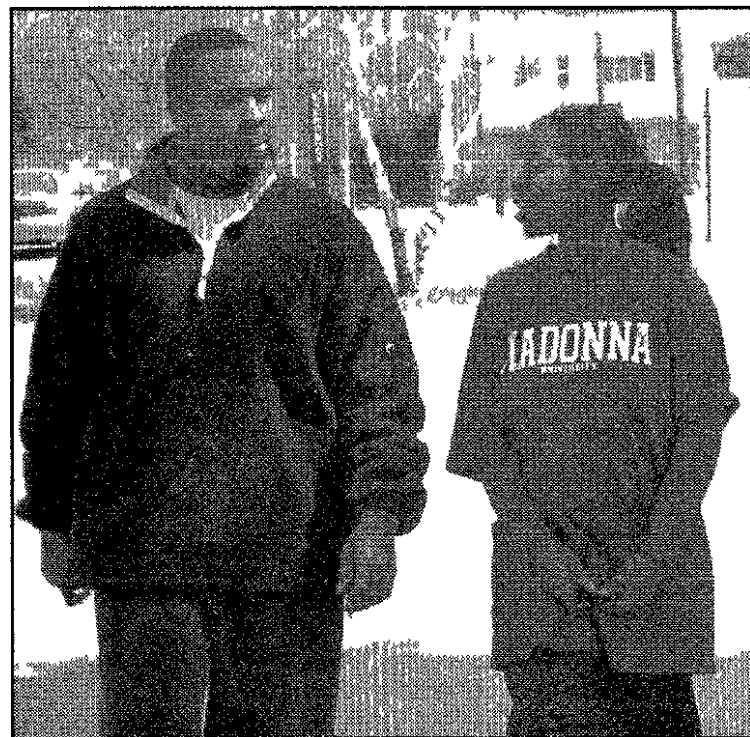

In memory: Tara Eddington of Livonia, a Madonna University student, and Wayne Wright of Detroit are walking the Avon 3-Day in honor of his mother, Erlene Wright, who lost her battle with breast cancer a few years ago

SENIOR CITIZEN FIX UP/CLEAN UP COMMUNITY SERVICE PROJECT

Saturday May 11, 2002

Sponsored by the Youth of Unity

Name _____ Age _____

Address _____

Phone _____

Handicaps or Special Needs _____

I would like help with the following

- | | | |
|--|---|---|
| <input type="checkbox"/> Yard Clean Up | <input type="checkbox"/> Check Smoke Alarm | <input type="checkbox"/> Install Screens |
| <input type="checkbox"/> Trim Bushes | <input type="checkbox"/> Window Washing | <input type="checkbox"/> Clean Refrigerator |
| <input type="checkbox"/> Clean Oven | <input type="checkbox"/> Change Light Bulbs | <input type="checkbox"/> Vacuum/Mop Floor |
| <input type="checkbox"/> Fix Doors | <input type="checkbox"/> Move Furniture | <input type="checkbox"/> Clean Car |
| <input type="checkbox"/> Clean Furnace Filters | <input type="checkbox"/> Dust | <input type="checkbox"/> Clean Garage |
| <input type="checkbox"/> Other Needs _____ | | |

Please mail to
Greg Adair AFFORDABLE HOMECARE 20270 MIDDLEBELT
SUITE 9 LIVONIA, MICHIGAN 48152

Got a broom? Help a senior!

BY RENÉE SKOGLUND
STAFF WRITER
rskoglund@oe.homecomm.net

For most of us, spring offers a chance to flex our muscles in cleaning out our houses and backyards. After all, isn't spring cleaning a rite of passage to a more relaxing summer? However, for senior citizens who no longer have the physical ability to trim bushes or wash windows, spring means hiring some body to do basic chores

Dick Adair, owner of Affordable Homecare in Livonia, believes in giving seniors a helping hand at this time of the year He has helped organize the "Senior Citizen Fix Up/Clean Up Community Service Project, sponsored by the Youth of Unity, a group of teens from The Church of Today West-Novl and The Unity Church of Livonia

Come Saturday, May 11, these teens - and their parents - will hit the streets armed with brushes, brooms and lots of good will And area seniors are not the only ones benefiting from the project

"Parents and teens work together in teams as a way to teach

children valuable lessons in home maintenance and respecting elders while providing an important community service," said Adair "It also gives teens a chance to be with the elderly, who often are not part of their lives"

Those qualifying for the free chore service include all persons 65 years or older living in Livonia, Farmington, and Farmington Hills, as well as any Unity congregation member Applicants will be selected based on need and the availability of workers Special consideration will be given to those with physical handicaps or difficulty performing activities of daily living

Seniors must fill out the application below and return it by May 4 to Greg Adair, Affordable Homecare, 20270 Middlebelt, Suite 9, Livonia, MI 48152 Seniors who are selected will be contacted

The project also needs lots of volunteers The more parents and teens involved in the project, the more seniors can be helped with spring chores The project begins at 8 30 a m and end when chores are completed

To volunteer or for more information, contact Greg Adair at (248) 477-4848 (work) or (248) 380-8236 (home)

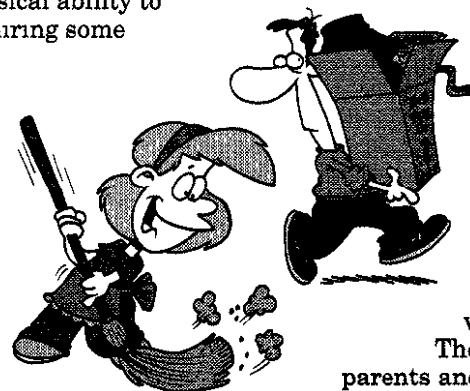

Motorcycles *from page C5*

I still remember that cruise through Minnesota country roads. The wind, the throaty sound of the engine, the white split rail fences whizzing by. Most of all, I remember my schizophrenic conversation, one outside my head and the other inside.

Outside "Oh, Jay, this is wonderful. Thanks for asking me."

Inside "Why haven't I done this before? Forget the kids, for get the housewife thing."

Outside "Oh, Jay, this is so much fun. Maybe you should ask Gary if he wants a ride."

Inside "Hey, Jay. Do you think anybody would miss us if we just kept on riding to Sturgis?" (Sturgis, South Dakota is the motorcycle Mecca for Harley dudes.)

One of Gary's aunts took a picture of me and Jay on his motor-

cycle after our ride. For many years, I kept it pinned to my refrigerator door. It eventually disappeared, just like my yearning for one more motorcycle ride.

Along came the Blessings of the Bikes, an opportunity to cover a great little story for our paper. About 50 bikers of all ages showed up, riding anything from small, fast sports bikes to house-size BMWs. I'll always be grateful to Dan for offering me a ride.

We were stopped at a red light in downtown Plymouth on our way back to St. Kenneth when Dan looked down at the four passengers wedged into the car next to us.

"You know," he said, "Looking at people driving cars on a day like this, I almost feel sorry for them."

Me, too, Dan. Me, too.

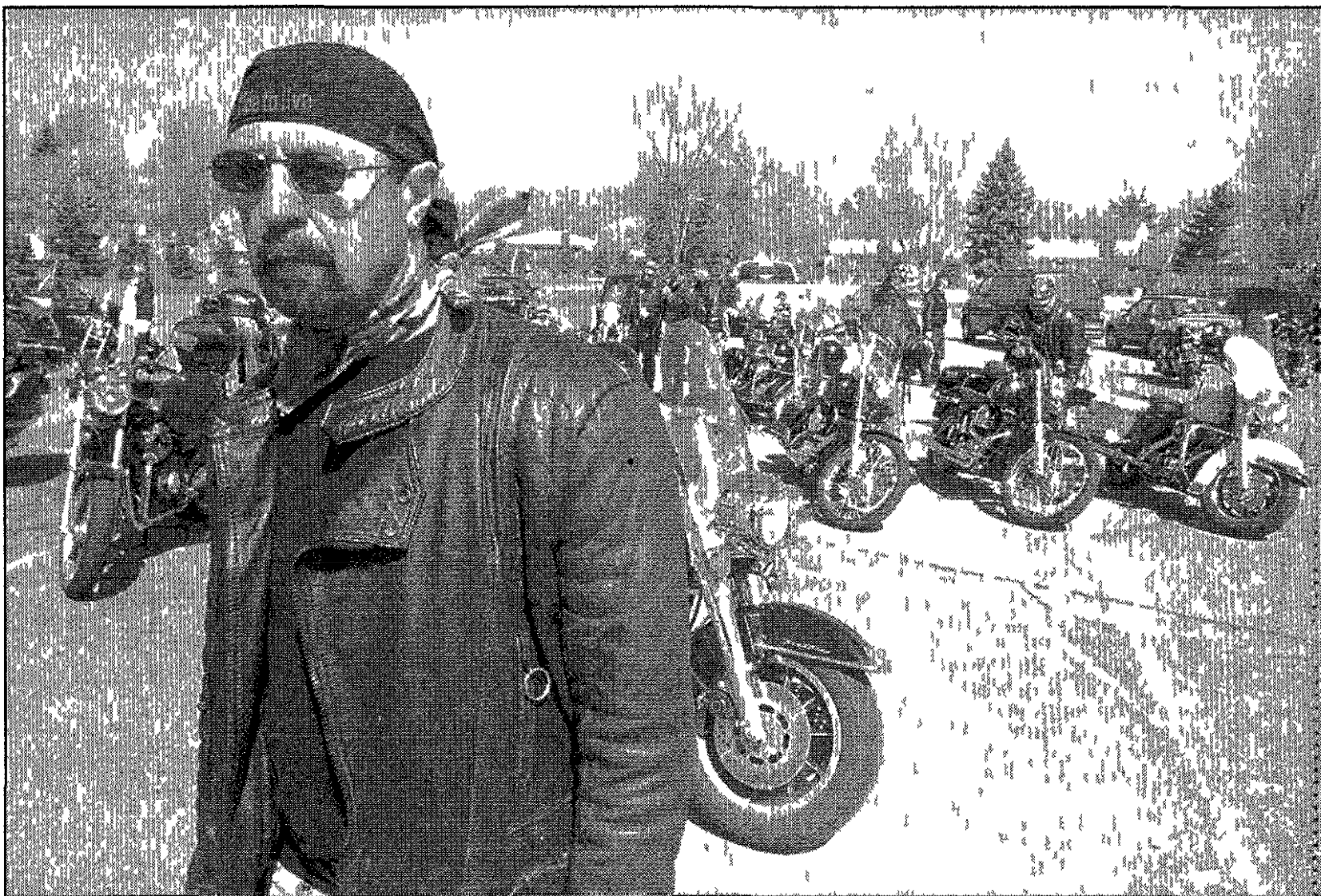

Harley dude: Retired Livonia fire captain Johnny Marson came ready to ride his Harley-Davidson 98 Heritage Softtail. And what color Harley does a fire captain own? Red, of course. My next ride will be on Marson's bike. Yo, mamma!



STAFF PHOTOS BY TOM HAWLEY

Vroom, vroom: Dan Sarb and I are heading off to the wild blue yonder on his Harley-Dyna-Superglide. Who cares if I'm about to become a grandma? Know where I can buy a cheap set of leathers?

SINGLES MINGLE

If you want to submit an item for the Singles Mingle calendar, fax it to our Farmington office (248) 477-9722 or Livonia office (734) 591-7279 or write *Singles Mingle*, Farmington Observer, 33411 Grand River, Farmington, MI 48335. The deadline an announcement to appear in the Thursday edition is noon Friday.

SINGLE MINGLES
Single Mingle dances are held selected Fridays throughout the month. For dates and locations, call the Metropolitan Single Professionals at (248) 851-9909.

WEST SIDE DANCES
West Side Singles hold dances hold Friday night dances at Bur-

ton Manor in Livonia. For dates and locations call (734) 981-0909.

BOOK TALK
Borders Books in Farmington Hills hosts a book discussion group 7:30-8:30 p.m. the second Wednesday of each month. Call (248) 851-9909.

AFTER WORK PARTIES
Metropolitan Single Professionals host "Fun and Fine Dining" 5:30-7:30 p.m. every Thursday at restaurants throughout the Detroit area. To find out locations call (248) 851-9909. Other activities include:

■ Dances held 8 p.m. - 1 p.m.

every Friday through May 3 throughout the Detroit area. Admission is \$5 members, \$8 non-members. Call (248) 851-9909 or visit www.mspsc.com.
n Euchre 6:30-9:30 p.m., every Monday through April at Cowley's Old Village Inn, 33338 Grand River Ave., east of Farmington Road, Farmington. \$5 for members, \$6 for non-members.

SINGLES WALK
Singles from First Presbyterian Church in Northville walk through Heritage Park in Farmington Hills at 10 a.m. every Saturday.

WARD SINGLES
Single Point Ministries of Ward Presbyterian Church (30 years and older) meet at 11:30 a.m. every Sunday in Knox Hall, for fellowship and encouragement. Ward is located at 40000 Six Mile Road in Northville. Call (248) 374-5920. Other Ward Singles events:
■ Classic senior Singles Bible Study meets 10 a.m. every Thursday.

CARDS & DINNER
Join the Farmington Single Professionals for euchre, pinochle and dinner from 6:30-9:30 p.m. every Monday at Crowley's Old Village Inn in downtown Farmington.

Read Observer Sports

Don't your employees deserve the security and peace-of-mind of Wayne County's HealthChoice?

With over 2,000 businesses and more than 21,000 members, Wayne County's HealthChoice is the fastest-growing health-care coverage in Michigan.



Not only because of its unmatched affordability - you and your employee each pay just \$43 a month* - but because of the exceptional quality of care HealthChoice provides.

'For the cost, we couldn't believe the coverage could be this good,' said Juan Haygood, owner of Pete's True Value Hardware. 'But it's true. HealthChoice is everything it says it is, and more.'



Including coverage for doctor's visits, emergencies, hospitalization, even prescription benefits. From a choice of six excellent provider networks.

For you, the Wayne County business owner, that means attracting better employees and retaining your best workers. For your employees and their families, it's peace-of-mind, security, not having to worry about being able to afford health care when needed.

And if your business isn't in Wayne County, maybe it should be.



health
CHOICE

Healthcare Coverage that's Good for Business
Call 1-800-WELL-NOW

* Single employee pays \$43/mo. and employer pays \$43/mo. family coverage costs more. call 1-800-WELL-NOW for more information.

The only tool you'll need to replace your siding, roofing or windows.

*Choose The Home Depot At-Home Services™ for your professional needs

Home Improvement Loans

No Payments & No Interest
for a purchases during the first 6 months after initial purchase on your Home Improvement Loan Card!

AT-HOME SERVICES

Installation and Maintenance You Can Trust.

1-877-77-DEPOT
for a FREE In-Home Consultation

- ✓ **Reliable**
On-time, courteous, respectful professionals working for you.
- ✓ **Quality Work**
Expect licensed and insured professionals who will get the job done right the first time.
- ✓ **Satisfaction**
All At-Home Services™ are guaranteed. The Home Depot will stand behind the service you receive.
- ✓ **Financing**
We offer 6-months no payments on purchases of \$299 or more on The Home Depot consumer credit card.

* Not all services are available at all stores.

As required. *Terms of guarantee may vary by service. See stores for details. **Where available. Subject to credit approval. ***Promotion available on new Home Improvement Loan accounts only. Subject to credit approval. Receipt of maximum credit line is subject to income and credit standards. You may pre-pay at any time without penalty. Interest does not accrue during 6-month no interest period. Not all purchases on Home Improvement Loan Card are \$2,000. Lic # AL 6074 CA 76365 & 777057 CT 569155 565322 DE 1997 12310 1999205108 FL CR C 058500 CO C033736 IL 104-012475 IA 66964-01 MD #62036 120396 MA 126893 129471 MI 2104 58644 2104 58225 ME C026438 MN DC 22052627 MS R05788 NJ L102870 RI # 9723161-0319 NV 53035 NY 1016793 HI 8E33570000 27857-HI 027347 H3306840000 273 9-HI 808 4467 PC2 76-A WCO 2309 HO OR C02414476 R 9427 13355 SD 27044 S02070 TN 3744 327 VA 2705-02516 A 2705 064904 WA HOMED R004LS DC 300072 7 WV W033258 W032988 W 630669 630322 02032 HOMER TLC Inc. All rights reserved.

Residents break bread, pray together at prayer events

Plymouth, Canton and Livonia are among communities nationwide that will celebrate the 51st National Day of Prayer on Thursday May 2. This year's theme is "America United Under God."

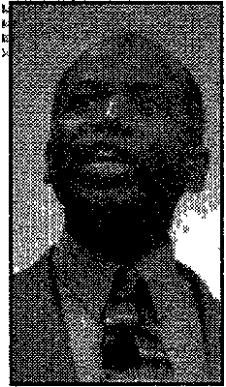

Prentice Tipton



Detroit Mayor Kwame Kilpatrick

The Plymouth Canton area's 12th annual Community Prayer Breakfast will feature Prentice Tipton, president of Challenge Ministry Detroit Mayor Kwame Kilpatrick will deliver a message of faith at Livonia's 28th annual prayer breakfast.

The Canton/Plymouth event begins at 7:15 a.m. in the Summit, 46000 Summit Parkway in Canton Township. Tickets are \$10 per person (includes continental breakfast and program) and tables of eight are available. Reservation deadline is Monday April 29. For tickets or more information, contact Sandra Bergeson at (734) 495-0426. The breakfast is sponsored by L.J. Griffin Funeral Home in Canton.

Tipton of New Baltimore is making his second consecutive appearance in Canton. His message was so powerful and well received by the community last year, that the committee invited him to speak again, said event chairwoman Sharon Turner.

"Since Sept. 11 many changes have taken place in our country. People are dealing with fear and interruptions to what we thought was a normal life," Turner said.

"We have asked Prentice to speak on God's wake up call to America and us in Canton and Plymouth, through the difficulties of the last year." Chris Jones and the Word of Praise also will perform at the event.

A segment of the program will be reserved for community prayer.

Livonia
In Livonia, Detroit Mayor Kwame Kilpatrick will deliver the keynote message of faith in Burton Manor, 27777 Schoolcraft Road, just west of Inkster. The breakfast begins at 7:15 a.m. The program ends by 9 a.m. Tickets are \$15 for adults and \$10 for students (includes a full breakfast and program) and are available by calling Sally Butler at (248) 476-9427. Tables of 10 are available.

The theme, "America, United Under God," is taken from Psalm 46: "God is our refuge and strength, an ever-present help in trouble." Jay Young, program chair for the Livonia event, says the theme acknowledges the difficult time the nation has endured since the tragic events of Sept. 11 and challenges us to stand united in faith.

Also featured at this year's event is the William Tyndale Artists Ensemble. The group will perform several selections including *Cry Out and Shout* by Knut Nystedt and *Give Me Your Tired, Your Poor* arranged by Ringwald. The group is under the direction of Jerry Smith.

Sister Mary Renetta Rumpz, provincial minister of the Felician Sisters of Livonia, and the Rev. Rick Peters of Rosedale Gardens Presbyterian Church will offer a Prayer for the Nation and the Benediction, respectively. Doors open at 6:45 a.m.

The National Day of Prayer tradition dates back to February 19, 1795, when President George Washington issued a proclamation setting aside a day of public thanksgiving. An annual day of prayer was established by Congress in 1952 and specifically designated in 1988 as the first Thursday in May.

Thanks to All of You, We are opening our second location!
LILY'S of Interlochen, Mi.
In Celebration we are offering **20% Off All Fabrics** thru 5-31-02
DICK'S UPHOLSTERY
19162 Farmington Road • Livonia • (248) 471-6590

Walking from page C1

out there and screen themselves. We need to prevent cancer before it happens. When they find out they have cancer I want the women to act on it, to get the best care possible," she said.

"The wonderful thing about the Avon breast cancer walk is it's for women who don't have insurance, don't have transportation, don't have spouses," she added. "It funds all sorts of programs that help underprivileged women with things like transportation and childcare."

It didn't take much coaxing on Madonna University student Tara Eddington's part to get her boyfriend, Wayne Wright, 24, of Detroit to join her in walking the Avon 3-Day Wright's mother, Erlene Wright, lost her battle with breast cancer a few years ago.

"As soon as I mentioned the walk, he said he'd definitely do it because of his mom," said Eddington, 24.

The two of them have split their training ground between Northville and Belle Isle. Their motivation has been sustained by the walk's purpose.

"Everybody has someone in their family who has died of breast cancer," said Eddington. "Every day I think why am I doing this, and I just think that every day someone will die for this if I don't help."

A generous response. When asked why she was

walking the 3-Day, Lin DeVore, 48, a registered dietitian who lives in Livonia, had a direct answer.

"Because I can do it. It's important to change how things are done - the screening, the treatment, the money behind it. I've seen co-workers struggle. It's a constant threat for all of us."

By March, DeVore was walking 35 miles a week. "It's amazing what the body can do," she said.

While sending out a form letter to help raise the \$1,900 has brought a poor response, co-workers and "friends of friends" have been generous," said DeVore.

"It's the cause that brings out the checkbook." Loper agrees. "I was wearing an Avon 3-Day walk pin the other day as I was walking out of Archie's restaurant on Plymouth Road. Another woman was walking in and spotted my pin. She gave me money on the spot."

She added, "People have been so generous. It's absolutely overwhelming."

For information about donating to the Avon Breast Cancer 3-Day in the name of any one of the women mentioned in this story, please contact Observer staff members Renee Skoglund at (734) 953-2128 or Sharon Dargay at (734) 953-2054.

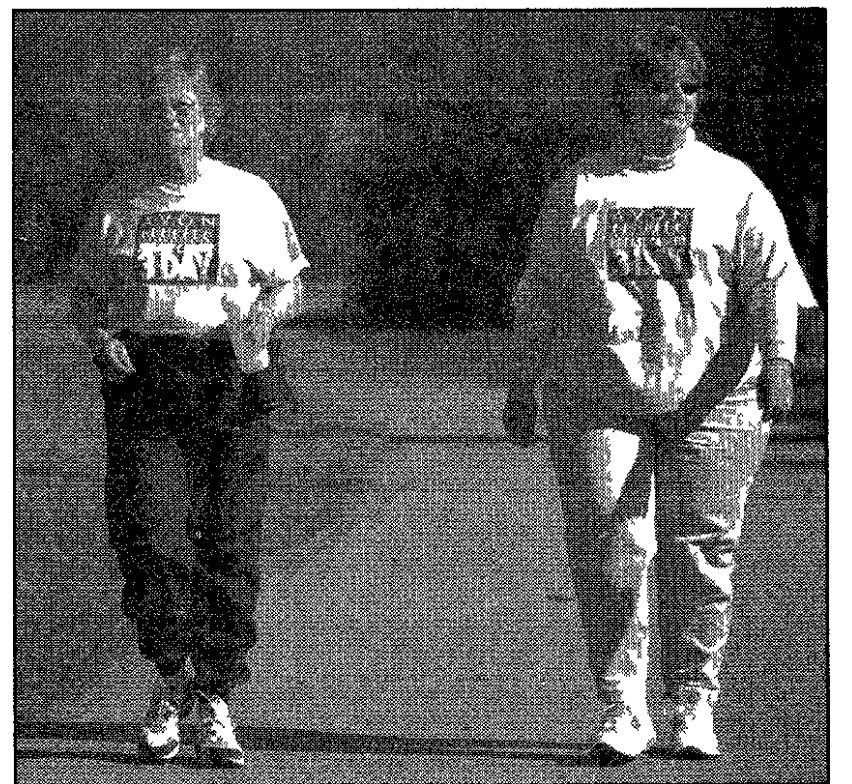

STAFF PHOTO BY JIM JAGDFELD

Dyno duo: Noreen Loper of Livonia and her daughter, Debbie Pluff, have been walking 15 miles through Hines Park several times a week in preparation for the 60-mile Avon Breast Cancer 3-Day from Ann Arbor to Detroit. Loper, a cancer survivor, said she's walking out of "gratitude."

Observer Classifieds sell!
Call (800) 579-SELL

COMMUTER EXPRESS
Brings you **Reliable Motorcoach Service to CASINO WINDSOR™**

DEPARTURES FROM:

- Auburn Hills • Bloomfield • Farmington • Novi
- Hamtramck • Madison Heights • Roseville • Southfield • Troy
- Livonia • Warren
- Sterling Heights • Westland • Dearborn • Taylor
- Lincoln Park • Wyandotte • Clinton Twp. • St. Clair Shores

\$5.00 (Per person) { Including \$1.5 Food Voucher or Lunch Buffet or \$1.5 in Gaming Coins }

Call 1-800-290-2957

Service provided by Commuter Express and is not affiliated with Casino Windsor. Trademark of the Ontario Lottery and Gaming Corporation used under license.

Absolutely, undeniably, the best Players Club in the market. PERIOD!

In the Detroit/Windsor area the players choice is the Players Prestige™ Club at Casino Windsor. With **MORE** perks, **MORE** privileges and now even **MORE CASH BACK** - we're the Casino that consistently gives you **MORE**:

- **MORE** play time - thanks to the favorable exchange rate and **MORE** chances to win!
- **MORE** Vegas style entertainment in the Show me Lounge!
- **MORE** luxury and style in our 4 diamond hotel.

And now we're giving you even **MORE CASH BACK**, because

DOUBLE CASH BACK IS BACK... MARCH 1ST - APRIL 30TH

Membership in the Players Prestige Club is **FREE** and entitles you to great rewards - plus **DOUBLE CASH BACK** for points earned from March 1st to April 30th, excluding noon on Saturdays to noon on Sundays. Sign up today! For **MORE** information call 1-800-991-7777.

CASINO WINDSOR™
More of what you're looking for!

Must be 19 years of age. Windsor Casino Limited reserves the right to cancel or change this event without prior notice. So. Fo. Fun. Not. Fo. Broke. 1.888.230.3505. Ont. o. P. ohem. Gambli. Ho. p.L. ne. POP 81 0508

FIND THE HELP YOU'RE LOOKING FOR

CFG inc. Observer & Eccentric **new ALICE**
THE **106.7 FM**
NEWSPAPERS

CAREER FAIRS

ATTENTION EMPLOYERS!
The Observer & Eccentric Newspapers joins Career Fair Group (CFG), Inc. and Alice Radio 106.7 FM for two Career Fairs.

A General Career Fair on Tuesday, May 21, 2002
Southfield Civic Center, Southfield

A Healthcare Fair on Wednesday, May 22, 2002
Burton Manor, Livonia

Both Career Fairs—9:00 - 4:00 p.m

★ **YOUR CAREER FAIR PACKAGE INCLUDES:**

- Advertising space on special recruitment pages in the Observer & Eccentric Newspapers (Ad size 4 1/4" x 6"—Publication May 19, 2002)
- 8-foot skirted table and chairs
- Lunch provided
- Inclusion in all Fair advertising in Observer & Eccentric Newspapers and its website and CFG Inc. website
- Radio promotion on 20 stations

TO RESERVE YOUR SPACE OR FOR MORE INFORMATION, CALL
★ **(734) 953-2070**

Southfield Civic Center, 26000 Evergreen, Southfield

Burton Manor, Between Inkster & Middlebelt, Livonia

Your Invitation To Worship

Mail Copy To:
Observer & Eccentric Newspapers
36251 Schoolcraft, Livonia MI 48150
Or Fax: (734) 953-2232

For Church Page Changes And Information Regarding Advertising In
This Directory, Please Call Jean Etherington (734) 953-2160
THE FRIDAY BEFORE PUBLICATION

BAPTIST

Pastor David Washington and The CCF Family would like to invite you to

Canton Christian Fellowship
"Where the Word is Relevant, People are Loved and Christ is the Key"
 Join us for Worship Service at 10:30am
 Sunday School and/or New Members Orientation 9:00am
 Located at 6500 N Wayne Rd • Westland MI
 Between Ford Road and Warren Road
 Inside Good Shepherd Church
 It's not about Religion, it's about Relationships
 Come to a place where lives are changed, families are made whole and ministry is real

NEW HOPE BAPTIST CHURCH
 33640 Michigan Ave • Wayne, MI
 (Between Wayne Rd & Merriman Rd)
 (734) 728-2180
Virgil Humes, Pastor
 Sunday School 9:30 a.m. Sunday Worship 8:00 & 10:45 a.m.
 Wednesday Praise Service 6:00 p.m.
 Wednesday Children, Youth & Adult Bible Study 7:00 8:00 p.m.



ASSEMBLIES OF GOD

You Are Welcome At
Tri-City Christian Center
 Michigan Ave & Hannan Road (1 mile east of I 275)
 734 326 0330 • www.Tri-City-Christian.com
Come Join Us
 Worship Service & Children's Ministries
 Selectives
 Youth Service
 Family Night

CATHOLIC

ST ANNE'S ROMAN CATHOLIC CHURCH
 Traditional Latin Mass
St Anne's Academy - Grades K-8
 23310 Joy Road • Redford Michigan
 5 Blocks E of Telegraph • (313) 534 2121
Mass Schedule
 First Fri 7:00 p.m.
 First Sat 9:30 a.m.
 Sun Masses 7:30 & 9:30 a.m.
 Confessions Heard Prior to Each Mass
 Mother of Perpetual Help Devotions
 Tuesdays at 7:00 P.M.

OUR LADY OF GOOD COUNSEL
 47650 N Territorial Road
 Plymouth • 453 0526
 Rev John J Sullivan
 Masses Mon-Fri 8:00 A.M. Sat 4:00 P.M.
 Sunday 8:00 10:00 A.M. and 12:00 P.M.
 5:00 P.M. Life Teen Mass

RESURRECTION CATHOLIC CHURCH
 48755 Warren Rd Canton Michigan 48187
 451-0444
 REV RICHARD A PERFETTO
 Weekday Masses
 Tuesday & Friday 8:30 a.m.
 Saturday - 4:30 p.m.
 Sunday - 8:30 & 10:30 a.m.

ST GENEVIEVE ROMAN CATHOLIC CHURCH & SCHOOL
 29015 Jamieson Ave • Livonia
 East of Middlebelt between 5 Mile & Schoolcraft Rds
 MASS Mon Wed Thurs Fri & Sat 9:00 a.m.
 Tues 7:00 p.m. • Sat 5 p.m.
 Sun 8:30 & 10:00 a.m. & 12:00 noon
 734-427-5220

CHRISTIAN SCIENCE

First Church of Christ, Scientist, Plymouth
 1100 W Ann Arbor Trail, Plymouth, MI
 Sunday Service 10:30 a.m.
 Sunday School 10:30 a.m.
 Wed Even ng Tea meetng Meetng 7:30 p.m.
 Reading Room
 Monday-Saturday 10:00 a.m. 1:00 p.m.
 Monday • Wednesday • Fr day 1:00 p.m. 4:00 p.m.
 453-0970

EPISCOPAL

ST. ANDREW'S EPISCOPAL CHURCH
 16360 Hubbard Road
 Livonia, Michigan 48154
 421-8451
 Wednesday 9:30 A.M. Holy Eucharist
 Wed (Sept-May) 6:00 P.M. Dinner & Classes
 Saturday 6:00 P.M. Holy Eucharist
 Sunday 7:45 & 10:00 A.M. Holy Eucharist
 Sun (Sept-May) 10:00 A.M. Sunday School
 Sunday Morning Nursery Care Available
 www.standrewschurch.net
 The Rev Aaron B Zull Interim Rector

CHURCHES OF THE NAZARENE

PLYMOUTH CHURCH OF THE NAZARENE
 45801 W Ann Arbor Road • (734) 453-1625
 Sunday School 9:45 A.M.
 Sunday Worship 11:00 A.M.
 Sunday Evening 6:00 P.M.
 Family Night Wed 7:00 P.M.
 NEW HORIZONS FOR CHILDREN 455-3195

CONGREGATIONAL

Mt. Hope Congregational Church
 30330 Schoolcraft Livonia • 734 425 7280
 (Between Middlebelt & Merriman)
 9:30 a.m. Sunday School
 10:30 a.m. Worship Service
 Nursery Care Available
 "The Church You've Always Longed For"



LUTHERAN CHURCH MISSOURI SYNOD

Christ Our Savior Lutheran Church
 Rev Luther A Werth Sr Pastor
 Rev Robert Bayer Assist Pastor
 With Jesus Christ love really can be all it was meant to be!
 Sunday Worship 8:30 am & 11:00 am
 Sunday School at 9:45 am
 Location 14175 Farmington Road (just north of I 96)
 734-522-6830 www.christsaviorsavior.org

GRACE LUTHERAN CHURCH MISSOURI SYNOD
 25630 GRAND RIVER at BEECH DALY
 532-2266 REDFORD TWP
 Worship Service 9:15 & 11:00 A.M.
 Sunday School 9:15 & 11:00 A.M.
 Nursery Provided
 The Rev. Timothy P. Halboth Senior Pastor
 The Rev Victor F. Halboth Assistant Pastor

Grace Lutheran Church
 46001 Warren Road • just west of Canton Center
 Sunday Worship at 9:30 am
 Sunday School at 10:45 am
 734-414-7422
 Our mission is to make disciples and send out disciples who share Christ with all people

Risen Christ Lutheran
 46250 Ann Arbor Road
 (1 Mile West of Sheldon)
 Plymouth • 453 5252
 Worship Service 8:15 & 10:45 a.m.
 Sunday School 9:30 a.m.
 Pastor David Martin
 Hugh McMartin Lay Minister

ST PAUL'S LUTHERAN CHURCH & SCHOOL
 20805 Middlebelt co. ne of 8 Mile & Middlebelt
 Farmington Hills Mich
 WORSHIP SERVICES
 Saturday Evening 6 p.m.
 Sunday Morning 9:15 a.m.
 Bible Class & Sunday School 10:45 a.m.
 Pastor John W Meyer • 474 0675

ST. MATTHEW LUTHERAN Church & School
 5885 Venoey
 1 Blk N of Ford Rd Westland 425 0260
 Divine Worship 8 & 11:00 A.M.
 Bible Class & SUNDAY SCHOOL 9:30 A.M.
 Monday Evening Service 7:00 P.M.
 Gary D Headapoint Admin strat ve Pastor
 Kurt E Lambert Assistant Pastor
 Jeff Burke Principal/DC E

EVANGELICAL LUTHERAN CHURCH IN AMERICA

Timothy Lutheran Church
 8820 Wayne Rd
 (Between Ann Arbor Trail & Joy Road)
 Livonia • 427-2280
 Rev Carla Thompson Powell, Pastor
 9:00 a.m. Sunday School (all ages)
 10:00 a.m. Family Worship (Nursery Avail)
 http://www.timothyLivonia.com

COMMUNITY CHURCHES

Orchard Grove Community Church
 Chris Cramer, Pastor
 Sunday, 9:30 & 11:15 A.M.
 Wednesday, 7:00 P.M.
 Located in
OLD ORCHARD THEATRE
 28123 Orchard Lake Rd
 Farmington Hills
 248-324-1700 www.orchardgrove.org

LUTHERAN CHURCH WISCONSIN SYNOD

Lola Park Ev. Lutheran Church & School
 14750 Kintoch • Redford Twp
 313-532-8655
 Rev Gregory D Gibbons Pastor
 Worship Sunday 8:30 & 11:00 a.m.
 Bible Class & Sunday School 9:45 a.m.
 Wednesday Advent Services 10:00 a.m. and 7:30 p.m.
 Grades K thru 8
 Phone for Enrollment Info
 WQLV 1500 - Sunday 10:30 a.m.

ST. PAUL'S EV. LUTHERAN Church & School
 17810 Farmington Road • Livonia • (734) 261 1380
 May thru October • Monday Night Service • 7:00 p.m.
 Sunday School & Bible Classes For all ages 9:45 a.m.
 Sunday Worship Services 8:30 a.m. & 11:00 a.m.
 Pastor James Hoff
 Pastor Eric Steinbrenner

EVANGELICAL PRESBYTERIAN

TRINITY PRESBYTERIAN CHURCH
 10101 W Ann Arbor Rd., Plymouth
 5 Miles W of Sheldon Rd
 From M 14 take Gottfredson Rd South
 734-459-9550
 Dr Wm C Moore Pastor
 Worship Services
 8:30 a.m., 9:45 a.m. & 11:15 a.m.
 Education Program
 9:45 a.m. & 11:15 a.m.
 Nursery & Children's Programs at All 3 Services
 FREE CONTINENTAL BREAKFAST

WARD Evangelical Presbyterian Church
 40000 Six Mile Road
 "Just west of I-275"
 Northville, MI
 248-374-7400
 Dr James N. McGuire, Pastor
 Worship Services
 Sunday School
 8:30, 10:00, 11:30 A.M.
 Contemporary Service • 8:45 A.M.
 Evening Service • 7:00 P.M.
 Nursery Provided
 Services broadcast 11:00 a.m.
 Sunday • WNUZ 560 AM

PRESBYTERIAN (U.S.A.)

ST. TIMOTHY PRESBYTERIAN CHURCH, USA
 16700 Newburgh Road
 Livonia • (734) 464 8844
 Sunday School 9:30 a.m. • Family Worship 11:00 a.m.
 "Do You Love Me?"
 Rev Janet Noble Richardson

GENEVA PRESBYTERIAN CHURCH (U.S.A.)
 5895 Sheldon Rd., Canton
 (734) 459-0013
 Sunday Worship & Sunday School
 9:00 a.m. & 11:00 a.m.
 Education For All Ages
 Childcare Provided • Handicapped Accessible
 Resources for Hearing and Sight Impaired
 www.genevachurch.org

Rosedale Gardens Presbyterian Church (USA)
 9601 Hubbard at W Chicago Livonia MI
 (between Middlebelt & Farmington Rds.)
 (734) 422-0494
 Contemporary Service 9:00 am
 Traditional Service 10:30 am
 Nursery Care Provided
 We Welcome You To A Full Program Church
 Rev Richard Pees Pastor
 Rev Kelcie Bohman Associate Pastor

FIRST PRESBYTERIAN CHURCH
 Main & Church • (734) 453 8464
 PLYMOUTH
 8:30, 9:30 and 11:00 a.m.
 Childcare Available
 Dr James Skirms Rev Richard Jones
 Senior Minister Associate Minister
 Accessible to All

UNITED CHURCH OF CHRIST

NATIVITY UNITED CHURCH OF CHRIST
 9435 Henry Ruff at West Chicago
 Livonia 48150 • 421 5406
 Rev Larry Hoxby Interim Pastor
 9:15 a.m. Adult Classes
 10:30 a.m. Worship Service
 and Youth Classes
 Nursery Care Available
 WELCOME

EVANGELICAL COVENANT

FAITH COVENANT CHURCH
 14 Mile Road and Drake Farmington Hills
 (248) 661-9191
 Sunday Worship
 and Children's Church
 9:15 a.m. Contemporary
 11:00 a.m. Traditional
 Child Care provided for all services
 Youth Groups • Adult Small Groups

UNITARIAN UNIVERSALIST

UNIVERSALIST UNITARIAN CHURCH OF FARMINGTON
 25301 Halsted Farmington Hills
 248-478 7272 www.uufarmington.org
 A 150-Year Old Historic Landmark
 A Welcoming Congregation
 Rev Alexander Ringel Minister
 Services & Sunday School 8am & 11am

UNITED METHODIST

"Building Healthy Families..."
 9:00 & 11:00 a.m. - Traditional Worship
 Contemporary Worship
 Dynamic Youth & Children's Programs
 Adult Education
 Child Care Provided
 Pastors Dr Dean Klump Rev Deborah Leach

Clarenceville United Methodist
 20300 Middlebelt Rd • Livonia
 474 3444
 Pastor James E Britt
 Worship Services 10:15 AM, 6:00 PM
 Nursery Provided
 Sunday School 9 AM
 Office Hrs 9-2 pm

First United Methodist Church of Plymouth
 45201 N. Territorial Rd. (West of Sheldon Rd.)
 (734) 453-5280

ST. MATTHEW'S UNITED METHODIST
 30800 Six Mile Rd (Bet Merriman & Middlebelt)
 Chuck Songquist Pastor
 10:00 A.M. Worship & Church School
 Logos Youth Club
 www.bgmg.unc.org/stmatthewsLivonia
 Nursery Provided • 734-422-6038

Catch the Spirit at Aldergate
United Methodist Church
 10000 Beech Daly, Redford
 Between Plymouth and W Chicago
 Bob & Diana Goudle, Co-Pastors
 313-937-3170
 3 Styles of Creative Worship
 8:00 a.m. - Cozy, Traditional, Basic
 9:30 a.m. - Contemporary, Family
 11:00 a.m. - Traditional, Full Choir
 Sunday School
 9:30 - Adults 11:00 - Children, Youth Adults
 Stephen-Stroned to Death
 Acts 7:54-60

NEWBURG UNITED METHODIST CHURCH
 Stephen Ministry Congregation
 36500 Ann Arbor Trail
 between Wayne & Newburgh Rds
 422-0149
 Worship Service
 9:15 & 11:00 a.m.
 Sunday School
 9:15 & 11:00 a.m.
 Rev Thomas G Badley
 Rev Barbara E Welbaum
 visit our website www.newburgumc.org

Pride and Humility

The dictionary defines pride as proper and justified self respect and a proper sense of personal dignity and worth. Everyone should take pride in their work, their family, their country and heritage. It is also good to take pride in things such as our personal appearance. When we take pride in all of the good things that our Lord has given us, we tend to take better care of them. However, we must be careful to have pride and self respect without arrogance or superiority. Children who are proud of their parents and respect them will try to be better children and do what is pleasing to their parents. As adults, we should always try to do what is pleasing in God's eyes. The Bible tells us that God opposes the proud, but gives grace to the humble (James 4:6). We should try to temper our pride with humility and not have an exaggerated opinion of our selves. The best way to be the best we can be is to be the best we can be. People who exalt themselves are usually esteemed less by others, and those who humble themselves are often more admired.

...do not think of yourself more highly than you ought, but rather think of yourself with sober judgment.
 N.I.V. - Romans 12:13

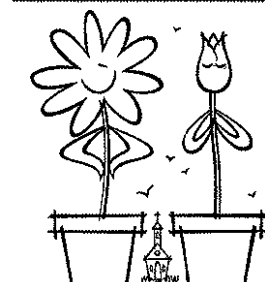

Event benefits developmentally disabled adults

Parisian in cooperation with The Arc of Northwest Wayne County and Community Opportunity Center presents "Celebrating Inspiring Heroes" beginning at 7 p.m. Sunday, April 28 in the store at Laurel Park Place, corner of Newburgh and Six Mile in Livonia.

Representatives from COC and Arc have teamed up to plan this special fund-raising event and say the only ingredient needed now is an audience. The group hopes to sell 500 tickets and raise at least \$10,000 for the two groups.

Tickets are \$25 per person and available from any sales associate in Parisian or by calling (734) 422-1020 or (313) 532-7915. Tickets also will be sold the night of the event. Admission cost includes entertainment by the Livonia Symphony Orchestra and food and beverages (wine and soft drinks) from 15 area restaurants including Laurel Park's newest restaurant, California Pizza Kitchen, Sweet Spot, Rocky's of Northville, Joe's Produce, Outback, Max & Erma's and Ground Round.

Eventgoers also will have an opportunity to shop at Parisian and receive a 15-percent discount on purchases that evening. Chris Edmonds of WNIC-FM and Miss Michigan, Stacy Essebagers, will emcee an auction fashion show.

A special raffle will feature prizes that include a trip for two to Grand Traverse Resort and Spa (includes golf), trip for two to a Marriott Golf and Spa Resort, golf at the new Northville Hills Golf and County Club, Red Wing playoff tickets, jewelry by Golden Gifts and many more.

The Arc of Northwest Wayne County and Community Opportunity Center provide services to assist people with developmental disabilities and their families in the pursuit of an independent and semi-independent lifestyle. The organizations serve people in Livonia, Canton Township, Northville, Plymouth, Westland, Garden City and Redford Township.

Demise King, executive director of COC, said more people are waiting for services but funding is an issue. The COC manages homes that serve about 100 residents ages 25-70.

"We have a lengthy waiting list — about 200 people — but funding is an issue," said King who has worked at COC for the last 22 years.

Over the years she has seen living models change — from large group homes to many more family-like settings. Many more developmentally disabled residents are remaining semi-independent and living in apartments while utilizing the services of COC and Arc.

COC provide staff support while Arc administers funding and provides social and recreational activities for developmentally disabled children and adults.

King said COC most recently worked with four women from Our Lady of Providence Center in Northville Township to provide 24-hour assistance in a Livonia home. The Northville Center is closing and residents had to find placement elsewhere.

The women, who range in age from 25-35, with help from their families and COC have rented a home in Livonia. COC is providing 24-hour staff support to help with such everyday activities as meal preparation, laundry, home maintenance and planning social activities.

King said the women's new arrangement is based on the self-determination model being used to service developmentally disabled adults throughout the country.

In this case, the women decided who they wanted to live with, where they wanted to live, what school and/or programs they

wanted to attend and who they wanted to staff the home. Families helped paint, decorate, do repairs and yardwork. The home opened a few weeks ago and residents and staff are pleased with the results.

King said money raised from Sunday's fund-raiser will help to enhance the lives of developmentally disabled children and adults throughout western Wayne County.

Honorary chairs for Sunday's event include Livonia Mayor Jack Kirksey, Canton Township Supervisor Tom Yack, Olympic Gold Medalist Sheila Taormina, former Detroit Red Wing Doug Brown, former Detroit Piston Vinnie Johnson, Wayne County Executive Edward H. McNamara, Livonia School Superintendent Kenneth Watson, U.S. Rep. Joe Knollenberg, State Rep. Laura Toy, Wayne County Commissioner Lyn Bankes, Livonia Family YMCA Executive Director Steve Peterson and Jackie McDougal of Parisian.

celebrating 50 INSPIRING HEROES

in mlife
**NEW YORK. DALLAS. SEATTLE.
SAME THING.**

no roaming
or domestic long distance
charges for life
anywhere on the
AT&T Wireless National Network

unlimited
night & weekend
minutes
for life
with a two-year agreement

plus anytime minutes:
300 for \$34.99
500 for \$49.99
1000 for \$74.99

save \$30
on a Sony Ericsson T60LX
with mail-in rebate
2 way text messaging capable
voice dialing
organizer with calculator and more
PHONES BY Sony Ericsson

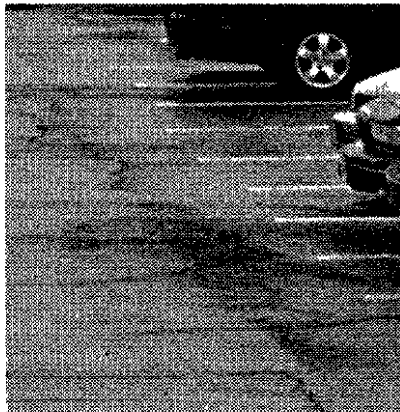

Anytime minutes, night & weekend minutes, and no roaming or domestic long distance charges apply to calls placed while on the AT&T Wireless National Network for as long as you stay on the same plan. Plus get up to \$36 waived activation fee with a two-year agreement.

J.D. Power and Associates ranked AT&T Wireless Highest in Overall Customer Satisfaction Among Wireless Users in Detroit.

1.800.IMAGINE® attwireless.com

HERE'S YOUR CHANCE TO FOLLOW THE TIGERS ALL THE WAY TO SEATTLE
Enter to win a trip for two to see the Tigers play in Seattle July 29th, 30th and 31st. You'll receive round trip airfare, hotel accommodations and more. Visit any Detroit area AT&T Wireless store today to enter.

mLife is your life made truly mobile.
welcome to mlife



Organization to award scholarships to students

The American Arab & Jewish Friends will sponsor its 16th annual awards and scholarship dinner on May 2 at the Detroit Marriott Renaissance Center.

Formed to bring Arab, Jewish and Chaldean Americans in the metro Detroit community closer together, the organization will present scholarships to Arab, Jewish and Chaldean high school students and will honor Judge George Caram Steeh III and attorney J. Leonard Hyman with its annual Friends Community Service Awards.

The reception begins at 6 p.m., with a dinner and program to follow at 7 p.m.

Tickets are \$125. Call Janice Bashl at (313) 567-6225 to register for the event.

The American Arab & Jewish Friends is a program of the National Conference for Community and Justice, dedicated to improving understanding between members of these communities in southeastern Michigan.

Approximately \$10,000 in scholarships will be awarded.

AT&T Wireless Stores		Ask about AT&T Wireless Gift Cards	
ANN ARBOR 926 W Eisenhower Pkwy 734-769-0299	BRIARWOOD MALL 814 Briarwood Circle 734 913 9257	DEARBORN 22137 Michigan Ave 313 565 2680	FLINT 3292 Linden Rd 810-733-1770
AUBURN HILLS 3922 Baldwin Rd 248 745 3806	BUSINESS SALES OFFICE 26877 Northwestern Hwy 888 839 4850	DETROIT 2660 E. Jefferson 313 259 1178	LIVONIA 37677 Six Mile Rd 734-462-1110
BIRMINGHAM 34200 Woodward Ave 248 593-8579	CANTON 43241 Ford Rd 734 981 2107	FAIRLANE TOWN CENTER 18900 Michigan Avenue 313 253 3999	MADISON HEIGHTS 32800 John R Rd 248 589 2770
MONROE, MI Frenchtown Square Mall 734 243 0533	NOVI 43267 Crescent Blvd 248 347 1843	ROSEVILLE 31902 Grattot 586-293 0142	TOLEDO 4906 Monroe St 419-473 9756
TWELVE OAKS MALL 27304 X Nov Road 248-449-9092	UTICA 13307 Hall Rd 586 254 0506		

AT&T Wireless Authorized Dealers				Wireless service also available at the following locations. Price and availability of equipment may vary. Call ahead for details.			
ANN ARBOR Ann Arbor Wireless 734-327 5100 CDS 734-741 7368 Wireless Toyz 734 332 0900 Wireless Toyz 734 477 7400	BELLEVILLE Metro Paging and Cellular 734 699 9080 DEARBORN Beyond Communications 313 565 5565 CDS 313-945 6670 CDS 313-945 5502 CDS 313-945 0775	CDS 313 982 0100 Telecom 2000 313 934 2000 Telecom 2000 313 277 2002 DETROIT Int'l Paging & Cellular 313 538 7474 FLAT ROCK Metro Paging and Cellular 734 789 0000 GARDEN CITY Wireless Toyz 734 261 0000 Wireless Toyz 734 261 0000 HIGHLAND Global Network Inc 888 666 4886	LIVONIA Beyond Communications 734-425-5900 Beyond Inc 734 425 5900 Discover Communications 734-266 1400 Wireless Times 248-442 1095 MADISON HEIGHTS CDS 248 542-8000 Champion's Cellular Warehouse 248-399 2700 Champion's Cellular Warehouse 248-583 5555 MILFORD Wireless Times 248 437 1095 NOVI Cellular Plus 248-682-1000	REFORD TOWNSHIP Discover Communications 313-794-1400 SHELBY TOWNSHIP Discover Communications 586-677-9600 SOUTHFIELD CDS 248-563 4800 Wireless Toyz 734 945 0990 SOUTHGATE Wireless Toyz 734 283-6600 Wireless Toyz 734 283 6600 STERLING HEIGHTS STERLING HEIGHTS CDS 810-566-9661	TAYLOR Discover Communications 734 759-1400 WARREN Mobile Toyz 810 755 1991 Wireless Toyz 586 578 1000 WATERFORD Champion's Cellular Warehouse 248 674 8888 Int'l Cellular & Paging 248 674 3200 YPSILANTI Ann Arbor Wireless 734 327 5400 Wireless Toyz 734-484 6000 Wireless Toyz 734-487 3000 Wireless Toyz 734-484 8000		

Important Information

©2002 AT&T Wireless All Rights Reserved. Requires new activation on a qualified AT&T Wireless calling plan, credit approval, activation fee, one or two year agreement, a Digital multi-network phone and a cancellation fee. Night and Weekend Minutes promotions available to you as long as you remain on the same rate plan and price point selected at activation. Not available for purchase or use in all areas. Your calls will be applied to your Included Anytime Minutes if you are in the Home Calling Area and on the AT&T Wireless network. Any calls placed outside of the Home Calling Area or off of the AT&T Wireless network will be subject to roaming and applicable long distance charges. Rates do not apply to credit card calls. Airtime for each call is rounded up to the next full minute. All text messages sent from your device incur a charge. Voice activated dialing only available for pre-programmed numbers on the T60LX. Monthly included and promotional minutes cannot be carried over to any other month. Roaming and additional minutes charges other restrictions, charges, surcharges and taxes apply. Not available with other offers. All offers and promotions available for a limited time. Subject to General Terms and Conditions and calling plan brochure. **Night and Weekend Minutes Promotions.** Available on calls placed from the Home Calling Area. Applicable long distance charges additional. Night and weekend airtime is from 9:00 p.m. to 5:59 a.m. Monday-Friday and Friday 9:00 p.m. through Monday 5:59 a.m. **Up to \$36 Waived Activation Fee.** Only available with signed two-year service agreement. You will be charged up to \$36 activation fee if signed two-year contract not received within 60 days of activation. **Sony Ericsson \$30 Mail In Rebate.** Phone must be active on AT&T Wireless service for 30 days and when rebate is processed. Sales tax applies to original purchase price. Certain restrictions apply. See Sony Ericsson mail in rebate coupon for details. Limited time offer **Tigers Offer. No Purchase Necessary.** Enter at any participating Detroit area AT&T Wireless store or at the AT&T Wireless kiosk at Comerica Park during any Tigers home game through 07/07/02 or register online at www.detroitigers.com. For Official Rules, including details on alternative means of entry, visit a Detroit-area AT&T Wireless store or www.detroitigers.com or write to AT&T Wireless, Detroit Tigers Road Trip, 26877 Northwestern Hwy, Suite 350, Southfield, MI 48034. Entries must be received by 11:59 p.m. on 07/07/02. Drawing will be held 07/10/02. Open to legal residents of the Detroit metropolitan area 21 or older, except employees or immediate family members of employees of AT&T Wireless, Detroit Tigers Major League Baseball and its Member Teams, MLB Properties Inc. or their respective affiliates or advertising/promotion agencies. One entry per person. One Grand Prize (ARV \$4,000) will be awarded. Odds of winning depend on number of eligible entries received. Restrictions apply. **J.D. Power and Associates Ranking.** J.D. Power and Associates 2001 U.S. Wireless Customer Satisfaction Study™ Study based on responses from 14,492 wireless telephone subscribers in 25 of the top U.S. markets. The Detroit market covers Lapeer, Livingston, Macomb, Oakland, St. Clair, Washtenaw and Wayne counties in the state of Michigan. www.jpdpower.com



RELIGION CALENDAR

If you want to submit an item for the religion calendar fax it to (734) 591-7279 or write Religion Calendar, Observer News paper, 36251 Schoolcraft Road, Livonia, MI 48150 The deadline for an announcement to appear in the Thursday edition is noon Monday

POETRY WORKSHOP

Christian Poetry writing workshop 2 3 30 p.m. Saturday, April 27, Northwest YMCA, 25940 Grand River Hosted by publisher of upcoming publication, African American Christian Poetry Admission \$15, refreshments served To register, call (313) 541-8124 or e-mail detroitwriters@aol.com

BIBLE CONFERENCE

Spring Bible Conference 7 p.m. Sunday, April 28 through Wednesday, May 1, Parkview Baptist Church, 9355 Stark Road, Livonia Guest Speaker Dr. Lee Robertson Call (734) 261-6180 for information

BREAKFAST PROGRAM

"Sharing Our Stories, Healing Our Hearts, and Celebrating God's Love" by Bobby Laughlin 9 15 a.m. Friday, May 3, Newburg United Methodist Church, (1/2 mile east of Newburg) 36500 Ann Arbor Trail, Livonia Service continues the idea of reconciliation, and honors Outstanding Young Church Women Bring pillows for Children's Hospital Cost \$2 for continental breakfast, call (734) 422-0149 for information If you need babysitting, call Landa Luke by Tuesday, April 30 at (734) 453-1599

MARRIAGE ENCOUNTER

Worldwide Marriage Encounter offers weekend experiences designed to help married couples improve communication and learn the value of intimacy, Friday-Sunday, May 17-19 at the St. John's Family Life Center, 44011 Five Mile, Plymouth Registration fee is \$50 (248) 528-2512 or (810) 286-5524 or www.rcnet/detroit/wwwme A Sept 20-22 session is also scheduled

ON-GOING

SCHOOL SIGN-UP

Hosanna Tabor Lutheran School, 9600 Leverage, Redford, is accepting applications for grades Pre-K-8th for the 2002-03 school year Limited space Call (313) 937-2233 for more information

MEMBERS SOUGHT

Canton Christian Fellowship is a multi-ethnic church seeking individuals and families who are interested in helping a bible based, evangelical Christian church grow and meet the needs of the Canton community We currently have 11 families that make up our church and we can use more help! If you are interested in the adventures of a start up church in Canton, please call Pastor David Washington Jr. at (734) 414-0856 Canton Christian Fellowship has been in existence for a year The church is affiliated with the Southern Baptist Convention of Michigan

WEDDINGS AND ENGAGEMENTS

SENNETT-ELLINGER

Larry and Joyce Sennett of Livonia announce the engagement of their daughter, Rosemary, to Travis Ellinger, of Lincoln, son of Doug and Peggy Ellinger of Lincoln

Rosemary is a 1997 Churchill High School graduate She's employed by DaimlerChrysler

Travis is a 1995 Alcona High School graduate and is employed by Bing-Lear Manufacturing Group

Both the bride-to-be and her fiancée hold bachelor's degrees in mechanical engineering from Lawrence Technological University

A May 2002 wedding is planned at St. John's in Plymouth



LIPPSTREU-ANTON

Dianne and Ken Lippstreu of Swartz Creek announce the engagement of their daughter, Traci Lynne, to Stephen Anton of Canton, son of Marian and the late Timothy Anton of Livonia Traci also is the daughter of the late Jim Fisher of Fenton

Traci has an associate's degree in accounting from ICS and is employed at Target Equipment Leasing, Inc

Stephen is a 1988 Churchill High School graduate He holds a degree in electrical engineering from Lawrence Technological University He's employed by Mr. Gasket Co



A May 2002 wedding is planned at the Summit on the Park in Canton Township

HUNTER-WOLLSCHLAGER

Kimberly E. Hunter, the daughter of Therese and Morris Hunter, and Michael J. Wollschlager, son of Connie and David Wollschlager, of Livonia, were married on July 21 at Ward Presbyterian Church in Northville

Kimberly is a 1992 graduate of Stevenson High School She earned her bachelor of science degree and two master of science degrees from Central Michigan University and is currently a fourth year doctoral candidate in the clinical psychology program

Michael is a 1992 graduate of Churchill High School He earned his bachelor of science degree in business and accounting from Central Michigan University and is employed as a certified public accountant in Mount Pleasant

Attending the bride was her sister, Kristen, as maid of honor Nicole Sabatine, Kristan Salna and Michele Wollschlager were



bridesmaids Isabella Tjerina was flower girl

Attending the groom was James Phillips, as best man The groomsmen were Sean Flatley, Jeff Harris and William Putnam

The couple received guests at a reception at Laurel Manor before leaving for a honeymoon in Aruba They are residing in the Mount Pleasant area

OPEN TO THE PUBLIC

PEWABIC POTTERY

COURTYARD TENT SALE

ARCHITECTURAL FIELD TILE • TILE OVERLAYS • BORDERS • EMBOSSED TILE

"Great for do-it-yourself projects"

30% DISCOUNTS FRIDAY, APRIL 26 & SATURDAY, APRIL 27, 10:00 am - 6:00 pm

30% DISCOUNTS SUNDAY APRIL 28, 12 Noon - 4:00 pm

10125 E. Jefferson Ave. at Cadillac 313-822-0954

*No other discounts apply. B1100784

Observer Classifieds sell!

Call (800) 579-SELL

Home Equity Credit Line

2.99% APR
Introductory rate for the first four months!

We're the one for tearing down interest rates!

4.50% APR
Then Prime minus 1/4% for the life of the line / \$10,000+

With a great rate like this right now is the perfect time to get a Home Equity Credit Line for

- Consolidating high rate credit card debt
- Refinancing an existing equity line or loan
- Save money with home improvements — *Don't want to move right now? Why not improve?*

Plus there are lots of other advantages

- No Closing, Title Or Appraisal Costs
- No Points Or Application Fee
- Interest May Be Tax-Deductible*

Apply Day or Night!

1-877-TOP-RATE
fom.com • Convenient Branch Locations

FIRST FEDERAL OF MICHIGAN

Branch offices throughout metropolitan DETROIT, OTSEGO, KALAMAZOO, OWASSO, DURAND, CHESEBAIN AND OKEMOS Extended hours weekdays and full service Saturdays at most branches.

*The 2.99% introductory Annual Percentage Rate (APR) is available for the first four months after activation. After four-month introductory period, fully indexed APR can change monthly based on Prime minus 1/4%, currently 4.50%. The APR is Prime plus a margin, if any, if the \$10,000 draw or transfer is not made. Prime is the highest Prime Rate published in the Money Rates section of The Wall Street Journal. Prime is a variable rate as it changes, the APR on your account will change. Offer subject to maximum combined 89.99% LTV (loan to value) and a maximum \$10,000 draw or balance transfer at time of activation. Annual Fee of \$100 will be due annually after the expiration of twenty-four (24) months from the date of the agreement. The Annual Fee shall be waived for each year that is a due if for the immediately preceding 12 months, the average outstanding balance on the credit line account during such 12 months is 20% or more of the Line of Credit. Lines of Credit are limited to owner-occupied 1-4 family principal residences and are subject to our underwriting standards. Property insurance required. Flood insurance may be required. Prepayment fee equal to 1% of highest outstanding loan balance owed since inception of the agreement, or \$350 whichever is greater will apply if Line of Credit Agreement is cancelled within one year. Relative to our maximum combined 89.99% LTV current offer, the 2.99% introductory APR is available for first four months after activation. After four month introductory period, fully indexed APR can change monthly based on Prime plus 1/3% margin, currently 6.50%. Annual Fee of \$125 will be due annually after the expiration of twelve (12) months from the date of the agreement. The Annual Fee shall be waived for each year that is due if for the immediately preceding 12 months, the average outstanding balance on the credit line account during such 12 months is 40% or more of the Line of Credit. Maximum APR on both products is 16%. Monthly payments of interest only will result in balloon payment at maturity. Offers are good on new Line of Credit requests only and are subject to change without notice. Consult a tax advisor regarding deductibility of interest. APR as of April 1, 2002.

Bay, Garden Window, & Door Sale!

Garden Windows

On Sale!

ROYAL WINDOW & DOOR

Bay Windows

On Sale!

ROYAL WINDOW & DOOR

All Door Units

On Sale!

ROYAL WINDOW & DOOR

BEFORE AFTER

Call Steve, Your Window Specialist & Start Your Home Improvement Early!

(248) 538-5900

FREE IN-HOME ESTIMATES!

Royal Results In Referrals!

SPORTS

CP

Thursday, April 25, 2002

OBSERVER SPORTS SCENE

Volpe a record-setter

She's certainly making the most of her final season. Stefanie Volpe, a senior third baseman for the University of Michigan's softball team and a Plymouth Salem graduate, set two team records last weekend in leading the Wolverines to an 11-1 win over Northwestern Saturday.

Volpe slugged two grand-slam home runs, driving in eight runs, in the victory — both of them school records. That and another home run hit in Sunday's 3-1 win at No. 21-ranked Iowa earned her Big Ten Player of the Week accolades.

Volpe went 5-for-12 (.417 batting average) with three homers, 10 RBI, six runs scored and four stolen bases for the week.

It was the fourth time in her U-M career she earned Player of the Week honors.

For the season, Volpe is batting .405 with seven homers, 43 runs scored, a .649 slugging percentage, a .549 on base percentage, 36 walks and 18 stolen bases — all of them team-highs. She also has 32 RBI, which is tied for second on U-M.

The Wolverines are ranked 12th in the NCAA with a 36-9 overall record, their 10-3 mark in the Big Ten puts them in second place, trailing only Ohio State (13-3). U-M plays single games at Illinois Friday and Saturday, then finish the weekend with a double header at Purdue Sunday.

Track standouts

Nick Allen set one meet record and won two events at Sunday's third annual Detroit Track and Field Classic at the University of Detroit Jesuit.

Allen, a Plymouth Salem graduate now attending Wayne State, won the mile in a meet-record 4:20.2. He also finished first in the 3,000-meter run in 8:55.3.

Ian Bedford, another Salem graduate and former UDM standout, finished 16th in the mile run in 5:03.8.

Ian Searcy, a senior at Central Michigan and a Salem graduate, led the Chippewas with two first-place finishes at the Western Michigan University Quadrangular April 20 in Kalamazoo.

Searcy won the 800-meter run in 1:51.12, then anchored the first-place 4x400 relay team (3:12.73).

CMU finished second in the meet with 152.5 points, with WMU first (263).

Tucker sparkles

Ben Tucker, a junior righthander at Kalamazoo College and a Plymouth Canton graduate, handcuffed the Michigan Intercollegiate Athletic Association's only unbeaten baseball team — Calvin College — in leading the Hornets to a 2-1 victory.

The win raised Tucker's record to 3-2 overall with a 1.60 earned run average. He has allowed seven earned runs in 39 1/3 innings pitched with 30 strikeouts, in the MIAA, he is 1-2 with a 2.49 ERA and 24 strikeouts in 25 1/3 innings.

Unfortunately for both Tucker and Kalamazoo, he was diagnosed with a strained ligament in his elbow after the game, which will sideline him for the rest of the season.

Through Sunday, the Hornets were 3-6 in the MIAA, 6-18 overall.

Oaks Red undefeated

The Canton Oaks Red under-9 boys select team was unbeaten at the Louisville Alliance Futbol Club Spring Invitational.

The Oaks Red outscored their three opponents 13-3. The team didn't qualify for the championship match, which was determined by a flip of a coin, but later discovered inclement weather cancelled the end of the tournament without any champions being crowned.

Members of the Oaks Red are Jesus Gmez, Tommy Halewicz, Travis Hall, Ryan Hayes, Danny Jasewicz, Shadi Jammoul, Joey Klowski, Kyle Krause, Alex Landschulz, Carson Lord, Ryan Mettlich, Mitchell Vaughn and Andrew Yoder. Also, guest player Brett Leary participated. The team is coached by Jim Lemley and John Vaughn.

Anyone interested in submitting items to Sports Scene or Sports Roundup may send them to sports editor C. J. Risak, 36251 Schoolcraft Livonia, MI 48150 or may FAX them to (734) 591-7279.

Figure skaters are finding their niche

BY C.J. RISAK
SPORTS EDITOR
cjrisk@oe.homecomm.net

It is, after all, a sport of individuals. Figure skating in a team sense goes no further than pairs, unless you're talking about some sort of team synchronized skating.

But individual figure skaters competing in some sort of team concept? No, never heard of it.

Before this past winter season, Plymouth-Canton Educational Park did have a figure skating team, and this team did qualify for the Michigan High School State Figure Skating Championships, which were held March 23 in Dearborn. If that was a surprise, consider this: The PCEP team didn't just compete, it finished seventh in a field of 32.

Considering what a team had to do to qualify, and considering that the PCEP team was in only its second season, that was quite an accomplishment.

FIGURE SKATING

"Some people think these girls don't work that hard that this isn't that difficult a sport," said team organizer Ellen Kolarik. "These girls train year-round."

Trying to understand the team scoring system can be difficult, even to those familiar with the sport. But let's try anyway.

First, there are two levels of team competition, High Teams and Low Teams. To compete in the High Teams, skaters must be qualified for the Juvenile Freeskating Division or higher (there are nine Freeskating divisions, ranging from Senior to Beginner Compulsory Moves, to move up a division, a skater must demonstrate certain skills).

In both the High Teams and Low Teams competitions, team members vie in three events: jumps, spins and moves. Each skater's score in that event is

then averaged together to determine the team's score in that element. A team's scores in those events — jumps, spins, moves — are added together to find the final tally.

To make the state finals, a team had to finish in the top three in its district during the season, comprised of three meets. PCEP's High Team placed eighth in its district out of nine teams, but its Low Team edged Northville for third place, scoring 26 total points during the districts compared to Northville's 24.

"This is just the second year in existence," noted PCEP team coach Barb Miller. "This year there was a lot more interest from kids of all levels."

The reason why is what makes the future of figure skating as a high school team sport so promising.

"Most of the kids on the team have skated five, 10, 12 years," said Kolarik. "But once they got to high school, they didn't have a place to compete, not for

Please see PCEP, D9

Salem stops Canton in 8

BY C.J. RISAK
SPORTS EDITOR
cjrisk@oe.homecomm.net

Any coach'll tell ya — win your one-run games and you'll stay in the title hunt. Of course, if you have a team of mostly underclassmen, you might want to avoid those close games.

Experience is the key factor in that type of game. Isn't it?

If it is, don't tell Plymouth Salem's baseball team. "We only had three seniors start today," said Rocks' coach Dale Rumberger a few minutes after his squad twice overcame two-run deficits in the late innings, then scored the game-winner in the eighth to upend Plymouth Canton 6-5 Wednesday at Canton.

It wasn't the first time something like this has happened to Salem. Matter of fact, Wednesday's one-run win was the sixth one-run game in a row for the Rocks.

With the win over Canton — by the way, it was Salem's second straight extra-inning affair — the Rocks were 4-2 in that stretch. With such a senior-lacking lineup, that shouldn't happen.

But it did. "We had plenty of chances," said Canton coach Scott Dickey. "But give them credit. Their hitters got hits when they had to."

That's true. In particular in the bottom of the seventh inning when, with two out and no one on base and Canton on top 5-3, Steve Cox (a sophomore) worked Chiefs' starter Matt Staley for a walk, the first walk issued by Staley in the game.

The next two Salem hitters, Mike Antich (a junior) and Drew Parling (a sophomore), bounced singles through the Chiefs' infield, Parling's hit scoring a run to make it 5-4. Dickey summoned Carl McDevitt to the mound, his diminutive (5-foot-9, 140 pounds) junior righthander who had not surrendered a run in 23 previous innings this season.

McDevitt got two strikes on Andy Thackaberry (a sophomore) before Thackaberry lined a base hit to left field, tying the game at 5-5.

"Thackaberry struck out five times at (Westland) John Glenn Monday," said Rumberger. "Yesterday he stayed after batting practice and we spent a lot of time working on his hitting."

The extra work paid off, allowing the Rocks to bounce back a second time. In the eighth inning, no more rebounding was necessary, Andy Boyer opened the inning with a walk, Cliff Thomas singled and Ryan Leach

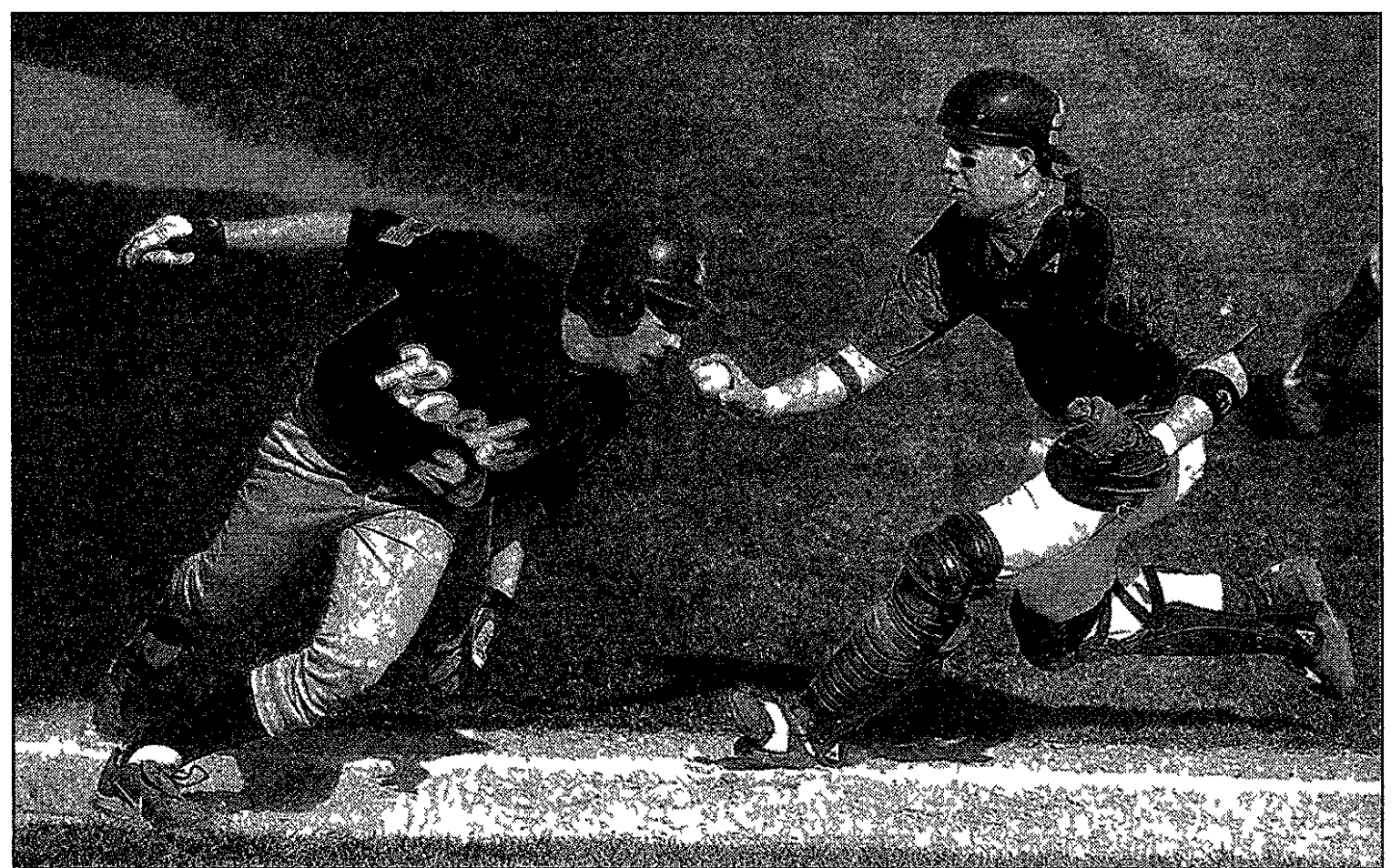

Run down: Salems Dylan Tobin (above left) gets caught in a rundown by Canton catcher Mike Tomasaitis, a play that saved the Chiefs a run. Still, the Rocks persevered, starting pitcher Kevin O'Berne (below) pitched five strong innings but weakened in the sixth, giving way to reliever Rickey Calleja.

laid down a sacrifice bunt to move them to second and third.

After Cox struck out, Antich walked to load the bases for Parling, who had shredded Glenn's pitching two days earlier for five hits. Parling lined a base hit to left to score Boyer with what proved to be the game-winning run.

"I think good teams win one-run games," said Rumberger. "That seems to be our M.O. (modus operandi). With this team, every game is exciting."

Wednesday's victory gave Salem a 7-4 overall record, 4-1 in the Western Lakes Activities Association. Canton is 8-4-1 overall, 2-3 in the WLAA.

The pitching win went to Rickey Calleja, who relieved starter Kevin O'Berne and allowed no runs on four hits and no walks in 2 2/3 innings. McDevitt, allowing his first run of the season, was the losing pitcher in relief of Staley, giving up one run on three hits and three walks in 1 1/3 innings.

Canton opened the scoring with two runs in the second. Nick Musselman started the inning with a double, Brent Kwiatkowski singled him home and advanced to second on the throw to the plate. One out later, Mike Tomasaitis singled in Kwiatkowski. Salem trimmed the Chiefs' lead to

2-1 with a run in the top of the third, scored by Andy Howald, who led off the inning with a single and came home on a two-out (of course) double by Cox.

Canton made it 3-1 on an infield single by Joe Kondratek and a double by Mark Hanson in the fifth, but the Rocks came back to score two in the top of the sixth, with the aid of some shaky defense by the Chiefs. Antich started the rally with a double, on Parling's grounder to shortstop, Antich was safe at third on the throw. Neil Kowalik and Jon Gordon followed with back-to-back, run-producing singles, knotting the score at 3-3.

Exceptional use of the bunt gave the lead back to Canton in the bottom of the sixth. Kwiatkowski singled to start the frame, Matt Kay and Tomasaitis laid down bunt singles, and when the ball got away from Boyer at first on Tomasaitis' bunt, Kwiatkowski scored the go-ahead run.

After Howald singled to load the bases, Calleja replaced O'Berne —

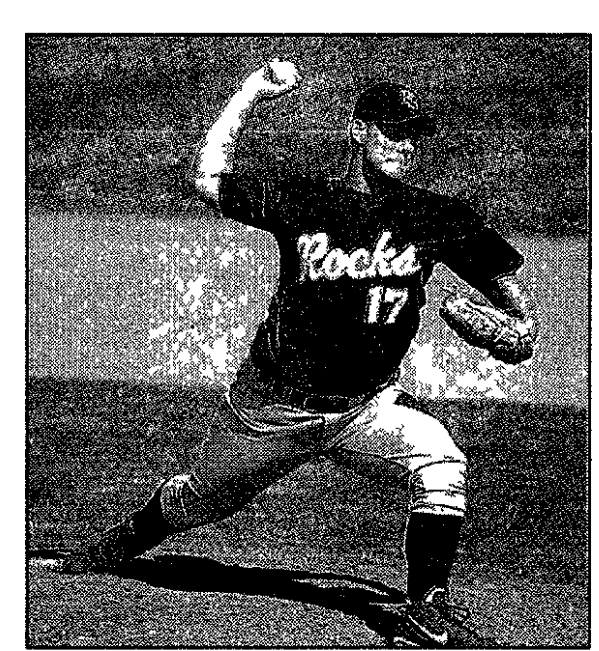

and was greeted by a perfect squeeze bunt single by Chris Pirch, making it 5-3.

"That was the worst defense we've played all season," said Dickey. "But again, give them credit. They did what they had to win."

And the Rocks did it in the clutch, with a young lineup that's quickly gaining a lot of experience.

Canton's Hanson leads Chiefs past Pats, 5-3

Mark Hanson did it on the mound and at the plate for Plymouth Canton's baseball team Monday as the Chiefs defeated Livonia Franklin 5-3 in a Western Lakes Activities Association Western Division game at Canton.

The Chiefs evened their division record at 1-1. Franklin is 1-1.

Hanson pitched the first six innings, allowing three earned runs on four hits and five walks, striking out nine. Carl McDevitt pitched the seventh inning, fanning two to earn the save and stretch his scoreless inning streak to 23.

Jason Rowe took the loss for the Patriots, allowing five runs in 5 1/3 innings.

At the plate, Hanson contributed run scoring singles in the first and sixth innings. Joe Kondratek added a double, a single and an RBI, and Matt Kay and Chris Birch each had a single and an RBI.

Mike Bugnell tripled in two first-inning runs for Franklin. He scored the Patriots' third run on Brandon Lee's squeeze bunt.

BASEBALL

John Glenn 6, Salem 5 (11 Innings): A dramatic, extra-inning struggle finally came to a close when Westland John Glenn scored an unearned run without the benefit of a hit in the bottom of the 11th inning Monday at Glenn.

The game went to extra innings tied at 2-2. Both teams got a single run in the ninth and each got two more in the seventh. Will Massey scored the game-winner for Glenn on a hard grounder to third, which followed walks to Nate Campbell and Ricky Verville.

Rickey Calleja was the losing pitcher for Salem in his one inning of relief, as the Rocks' WLAA Lakes Division record slipped to 1-1. Neil Kowalik started and allowed two runs in six innings.

Kyle Rutkowski got the win for the Rockets, who are

6-3 overall, 2-0 in the division. The loss overshadowed a superb offensive performance by Drew Parling, who had five hits for Salem, including three doubles. Steve Cox added two hits.

Brian Ceckiewicz had three hits to lead Glenn, including RBI singles in the ninth and 10th innings. Massey and Julian Fraser added two hits apiece for the Rockets.

Salem 6-1, Southgate 5-2: The Rocks won the first game Saturday at Southgate Anderson thanks to a pair of run-scoring singles by Dylan Tobin and some quality relief pitching by Andy Boyer.

Steve Cox scored a run in the first on an error and Brian Bradley's grounder brought home another run for Salem in the second. Anderson got a run in the first and went ahead with two more in the third before the Rocks rallied with two runs in the fifth and two more in the seventh.

Please see CHIEFS, D7

Salem takes 2nd at Port Huron Huskies Relays

After an ominous start events took a turn for the better for Plymouth Salem's girls track team last Saturday at the Port Huron Huskies Relays.

Indeed, were it not for the Macomb L'Anse Creuse track team, Salem's team may never have gotten started at all. En route to the Relays, the Rocks' bus broke down, about five miles away from the relays' site.

"The L'Anse Creuse bus picked us up," said Salem coach Mark Gregor. "We were there on time. Those people were really, really nice."

Once there, the Rocks kicked it into gear, placing second in the 22-team field Rochester Adams won the meet with 108 points, Salem scored 69, followed by St. Clair (59) and Ann Arbor Huron (55).

The Rocks had six third place finishes and four fourths. Indeed, depth was the difference for them. They scored in 15 of the 16 events they entered. There were also four co-ed relays in which Salem had no entry, which did give Adams an advantage.

"Under difficult circumstances, it was a very competitive meet,"

GIRLS TRACK

said Gregor, referring to the cold temperatures. "We did very well. It was one of those meets where you can get a lot out of it or get nothing, and we got something positive. If they can compete hard in those circumstances, think how nice it will be in good circumstances."

Four of Salem's six thirds came in track events. Included were the 4x800 meter relay team of Kara Dendrinis, Jill Grey, Laura Friedman and Lauren Kane (10:32.4), the 4:800 relay of Friedman, Dendrinis, Grey and Kane (17:15.9), the 4x100 team of Stacey Schmedding, Celena Davis, Melissa Drake and Susan Woodard (54.4), and the distance medley team of Erin Jensen, Grey, Lianne Griffiths and Lisa Keski Hynnla (14:34.5).

The third-place finishes in the field events came from the discus relay team of Ashleigh Shear, Lori Cairo and Shannon Stott (243 feet, 1 1/2 inches) and from the long jump relay team of Davis, April Aquinto and Terease Chandler (39-9).

Salem's fourths came from the

pole vault relay of Jenny Jedlick, Ashley Aquinto and Kim Blaha (20-0), from the 8,000 relay of Erin Jensen, Laura Baumgart, Stephanie Hajduk and Griffiths (32:00.6), from the sprint medley of Chandler, Vicky Rozalski, Carolyn Heaney and Kane (3:18.1), and from the 4x400 relay of Errane Bundle, Dendrinis, Drake and Chandler (4:36.6).

The Rocks had two fifth-place finishes, from Lindsay Miles, Drake and Lynden Gault in the high jump relay (13.0) and from Woodard, Cairo and Shear in the shot put relay (85.11 1/2).

The shuttle hurdle relay of Schmedding, April Aquinto, Andrea Lang and Stephanie Olli placed sixth (1:15.6), the 4x200 relay of Bundle, April Aquinto, Drake and Woodard was seventh (1:56.0), and the 2,400 relay of Amy Masterson, Stephanie Knight, Gault and Lang was eighth (8:09.0).

The Rocks have a Western Lakes Activities Association dual meet at Farmington today. On Saturday, they compete at the West Bloomfield Invitational.

TENNIS RESULTS

PLYMOUTH SALEM 8 WALLED LAKE CENTRAL 0 Tuesday at Salem

No 1 singles: Evan Roller (PS) def. Chris Price 6-0 6-1
No 2: Mike Ware Jr (PS) def. Dave Brown 6-2 6-4
No 3: Dave Wallen (PS) def. Pat Henzie 6-0 6-2
No 4: Dave Daigneau (PS) def. Jason Wells 6-1 6-3
No 1 doubles: Kyle Jose Pat Shaw (PS) def. J.R. Berry-Brennan Willis 6-3 6-4
No 2: Sameer Dohadwala-Chris Treadwell (PS) def. An Friedman Fadi Saukari 6-3 6-4
No 3: Jeff Sibbold Dave Kwak (PS) def. Mike Otewski Pat Muller 6-3 6-0
No 4: Jason Rizzo Pat Tokarsky (PS) def. Ako Fukuta Yoshi Niwa 6-1 6-1
Dual-meet record: Salem 3-0 in the WLAA. **Next match:** John Glenn at Salem 4 p.m. today.

REDFORD CATHOLIC CENTRAL 7 GROSSE POINTE LIGGETT 1 Monday at Schoolcraft

No 1 singles: Alexander Contr (UL) def. David Apalliah 6-1 6-3
No 2: Billy Walsh (CC) def. Shyam Guthiconda 6-2 6-0
No 3: Jason Beydown (CC) def. Aaron Breden 6-0 6-0
No 4: Britton Steele (CC) def. Justin Powell 6-1 6-1
No 1 doubles: Mark Blazar Paul Switaj (CC) def. Ted Ottaway Hunter Hutg 7-5 6-1
No 2: Kevin Bender Steve Doot (CC) def. Koebe Mosher C T Charlton 6-1 6-2
No 3: Kevin Gardner Ryan Snyder (CC) def. Trevor Stahl Dan LaLonde 6-1 6-2
No 4: Ali Daneshdar Gabe Diaz (CC) def. Owen Darr Peter Spina 6-1 6-0

BEST GIRLS TRACK PERFORMANCES

SHOT PUT Nia Henderson (Churchill) 36-1 1/4 Susan Woodard (Salem) 34-8 1/2 Jennifer Early (Salem) 33-7 Anne Roosevelt (Mercy) 33-6 Jessica Bailey (Canton) 32-7 Valesha Turner (Mercy) 32 3 1/2 Lon Cairo (Salem) 30-6 Jocelyn Atkins (Farmington) 30-0 Diane Hawkins (John Glenn) 30-0 Tann Dew (Harrison) 29-7	100-METER HURDLES Whitney Johnson (Mercy) 16 1 Stacey Schmedding (Salem) 16 7 Latoya Burrell (Harrison) 17 3 Angela Adams (John Glenn) 17 3 Angela Fodor (Harrison) 17 4 April Aquinto (Salem) 17 5 Jamila Far (Harrison) 17 5 Ashton Frederick (Farmington) 17 8 Colleen Bosman (Stevenson) 17 9 Laura Borovsky (Churchill) 18 2 Jen Loomis (Luth. Westland) 18 2	800-METER RUN Kara Dendrinis (Salem) 2:30 1 Lisa Montgomery (Stevenson) 2:34 0 Michelle Phillips (Churchill) 2:34 6 Linda Montgomery (Stevenson) 2:34 9 Jill Grey (Salem) 2:35 6 Erin Jung (Luth. Westland) 2:37 9 Tess Kuehne (Luth. Westland) 2:38 0 Kristin Balla (Farmington) 2:38 2 Rachel Lindman (Canton) 2:39 6 Angie Matthews (Luth. Westland) 2:39 9
DISCUS Anne Roosevelt (Mercy) 109-11 Tann Dew (Harrison) 105-10 Lauren Kmet (Franklin) 100-2 Ashleigh Shear (Salem) 99-10 Valesha Turner (Mercy) 96-10 Sue Hand (N. Farmington) 96-0 Nia Henderson (Churchill) 94-4 Jennifer Early (Salem) 89-8 Jocelyn Atkins (Farmington) 87-10 Paula Edwards (Stevenson) 86-10	300-METER HURDLES Whitney Johnson (Mercy) 49 2 Angie Matthews (Luth. Westland) 49 4 Angela Adams (John Glenn) 51 3 Erriane Bundle (Salem) 52 1 Stacey Schmedding (Salem) 52 1 Lindsay Hall (Farmington) 52 2 Colleen Bosman (Stevenson) 53 3 Andrea Lang (Salem) 53 3 J.Q. Williams (Canton) 53 7 Latoya Burrell (Harrison) 54 1 Amy Masterson (Salem) 54 1	1,600-METER RUN Michelle Phillips (Churchill) 5:27 9 Christine Metry (Harrison) 5:28 0 Susan Barrows (N. Farmington) 5:33 6 Sarah Westrick (Churchill) 5:37 0 Rachel Button (Farmington) 5:39 9 Susan Durcan (Churchill) 5:41 9 Nicole Schmidt (Churchill) 5:44 0 Nicole Moundros (N. Farmington) 5:44 2 Lisa Montgomery (Stevenson) 5:47 0 Lindsay Gould (Churchill) 5:49 3
HIGH JUMP Karen Abramczyk (Luth. Westland) 5-2 Betty Wade (Farmington) 5-0 Megan Kmet (Franklin) 4-10 Karen Kuszyński (Ladywood) 4-10 Ashley Kasprovecz (Mercy) 4-10 Angela Adams (John Glenn) 4-10 Lindsay Miles (Salem) 4-8 Melissa Drake (Salem) 4-8 Katie Cezat (Canton) 4-8 Cindy Rotramel (Canton) 4-8 Katie Caille (Canton) 4-8 Jessica Leadford (Canton) 4-8 Jenna Pratt (Stevenson) 4-8 Cornelia Simmons (Wayne) 4-8	400-METER DASH Alexandra Marshall (Mercy) 12 5 To Inia White (John Glenn) 12 7 Alyse White (Churchill) 12 9 Erika Branch (Mercy) 12 9 Kate Bouschet (Farmington) 13 1 Erriane Bundle (Salem) 13 1 Christina Redd (Canton) 13 1 Krystal Wise (Harrison) 13 3 Jessica Shamberger (Salem) 13 5 Amber Lee (Canton) 13 5	3,200-METER RUN Susan Barrows (N. Farmington) 11:56 1 Nicole Moundros (N. Farmington) 12:07 0 Sarah McCormack (Canton) 12:24 1 Lianne Griffiths (Salem) 12:24 7 Christine Metry (Harrison) 12:29 5 Claire Czaplacki (Farmington) 12:39 3 Lauren Kane (Salem) 12:50 7 Heather Sirko (Stevenson) 12:51 0 Sara Pilon (Stevenson) 12:51 9 Lindsay Gould (Churchill) 12:58 0
LONG JUMP To Inia White (John Glenn) 16-4 Elizabeth Easter (John Glenn) 16-1 1/2 Julietta Iarina (Harrison) 15-11 Rachel Lindman (Canton) 15-8 Melanie Banks (Harrison) 15-5 1/2 Danielle Underwood (Mercy) 15-4 Colleen Bosman (Stevenson) 15-3 Kate Bouschet (Farmington) 15 3/4 Celena Davis (Salem) 15-1/2 Dominique Powells (Redford Union) 15-0	200-METER DASH Alexandra Marshall (Mercy) 26 3 Whitney Johnson (Mercy) 26 9 Rachel Lindman (Canton) 27 3 Elizabeth Easter (John Glenn) 27 5 Krystal Wise (Harrison) 27 7 Errane Bundle (Salem) 27 8 Jessica Shamberger (Salem) 27 9 Melanie Banks (Harrison) 27 9 Betty Wade (Farmington) 28 0 Christina Redd (Canton) 28 2 Dominique Powells (Redford Union) 28 2	400-METER RELAY Westland John Glenn 52 3 Plymouth Salem 52 9 Livonia Stevenson 53 3 Livonia Ladywood 53 4 Farmington Harrison 53 5
POLE VAULT Julietta Iarina (Harrison) 9-0 Jenny Jedlick (Salem) 8-6 Brittin Pollack (Salem) 8-6 J.Q. Williams (Canton) 8-0 Andrea McMillan (Franklin) 8-0 Yukiko Sueda (Stevenson) 8-0 Angie Matthews (Luth. Westland) 8-0 Ashley Bolland (Canton) 7-6 Sarah Sargol (Harrison) 7-6	400-METER DASH Linda Montgomery (Stevenson) 1:01 5 Betty Wade (Farmington) 1:02 2 Stephanie Dean (Churchill) 1:04 0 Melissa Drake (Salem) 1:04 6 Angie Matthews (Luth. Westland) 1:05 5 Lindsay Branch (Harrison) 1:05 7 Jessica Caldwell (Franklin) 1:06 0 Angela Anieros (Churchill) 1:06 1 Kristen Barlett (Canton) 1:07 0	800-METER RELAY Westland John Glenn 1:50 8 Plymouth Salem 1:52 0 Redford Thurston 1:52 0 Plymouth Canton 1:53 2 Farmington Harrison 1:53 8
	1,600-METER RELAY Livonia Churchill 4:21 9 Plymouth Salem 4:24 6 Lutheran Westland 4:25 6 Plymouth Canton 4:28 8 Livonia Stevenson 4:29 0	3,200-METER RELAY Plymouth Salem 10:21 3 Livonia Stevenson 10:26 0 Plymouth Canton 10:39 0 Lutheran Westland 10:39 1 Livonia Churchill 10:42 7

BURTON'S
Plumbing & Heating
BATH and KITCHEN REMODELING

- Licensed Master Plumber
- Ceramic Tile Installed
- Quality Materials and Workmanship

FREE ESTIMATES
Visit Our Full Kitchen and Bath Showroom

(Same location since 1975)
34224 Michigan Avenue
Wayne, Michigan 48184
(734) 722-4170

Salem stops Rockets in 12-6 win

Maggie Tudor collected three hits — two of them doubles — and drove in five runs to lead Plymouth Salem to a 12-6 victory over Western Lakes Activities Association Lakes Division rival Westland John Glenn Monday at Salem.

The Rocks led 5-2 after four innings, a five-run fifth put the game away. Jill Posler got the pitching win, allowing six runs (four earned) on eight hits and seven walks, striking out seven.

Alycia Murawski had three hits and an RBI for Salem, which improved to 2-0 in the Lakes, 4-3 overall. Cortney

SOFTBALL

Edwards added two hits and a run batted in, and Rachel Heid had two hits. Ruth Kieitka gave up 12 runs on 15 hits and three walks, striking out three for the Rockets. Erica Novack led their offense with three singles, Kathryn Fowler had a two-run double.

Last Saturday at the Taylor Tournament, Salem won two of three games, losing 10-7 to Garden City in nine innings on a grand slam home run by Terra Russell.

The Rocks aided their own demise in the ninth with three walks and an error. Tudor and Szawara led them offensively with three hits apiece (including a double each), Szawara had one RBI. Jess Bonello, Brook Posler and Mandy Bradley each had run-scoring singles. Kelly Szczepanski took the loss, pitching all nine innings and allowing five hits and four walks.

Salem's two wins in the tournament included a 3-1 victory over Lincoln Park. Jill Posler was the winning pitcher, allowing one run on six hits and one walk, striking out three. Rachel Heid had two singles and an RBI, and Bonello had a run-scoring single to pace the Rocks' offense.

In their second game, the Rocks merited Thurston 16-0 in five innings. Michelle Jurcak got the win with a three-hitter, striking out 11.

Courtney Edwards led Salem with two home runs, including a fifth-inning grand slam, and six RBIs. Szawara also had two hits, one a three-run homer in the third. Murawski had three hits including a double and an RBI. Brook Posler had two doubles and four RBIs and Tudor had two hits.

Canton 12, Franklin 1: Either Livonia Franklin isn't quite as good as its previously unbeaten record had indicated, or Plymouth Canton is better than anybody thought — and still improving.

The Chiefs' outstanding pitching continued, this time from Michelle Roelofs, who tossed a two-hitter at the Patriots. Roelof, who improved to 2-0, walked one and struck out five in Monday's five-inning mercy that dropped Franklin to 5-1 overall, 1-1 in the WLAA's Western Division. Canton is 2-0 in the division.

Roelof, Sabrina Gorney, Danielle Weber and Caitlin McNicholas each had two hits for the Chiefs.

"We're doing real well offensively and defensively," said Canton coach Jim Arnold. "We only had one error (against Franklin)."

Nikki Zabkiewicz started on the mound but lasted just 2 2/3 innings for Franklin.

Agape 14, Greenhills 4: Lisa Ther collected three hits, three stolen bases and four runs batted in for Canton. Agape Christian Friday against Ann Arbor Greenhills in a game played at Griffin Park. Livi Moore added two hits, three steals and four runs scored and Amy Henry had two hits, three steals and two runs scored for the Wolverines. Henry got the pitching win.

Largest set of grass tees in Oakland County!

Beech Woods Driving Range
22202 Beech Road Southfield

Two For One Golf
Bring this coupon in for 2 for 1 green fees 11:00am thru 3:00pm Monday - Friday at
The Beech Woods Golf Course
22202 Beech Road • (248) 354 4786 and
The Evergreen Hills Golf Course
26000 Evergreen Road • (248) 354 4866

Southfield Expires June 1st

COYOTE GOLF CLUB
www.coyotegolfclub.com

Seniors (50+)
Ladies (any age)
Juniors (24 & under)
Monday-Friday before Noon or Saturday/Sunday/Holidays after 3pm
18 Holes with cart \$32 or any combo of 2 for \$54
248-486-1228
On Milford Road 1 mi. south of I-96

3 FREE Junior Clinics Starting Saturday, April 20

The Observer & Eccentric

GOLF DIRECTORY

For information about Advertising in this Golf Directory
Please Call Dylan
(734) 953-2073

CITY OF LIVONIA GOLF DIVISION

SNAG GOLF

Golf instructors will provide the juniors with basic fundamentals of the game, along with the proper rules and etiquette in a SAFE and EXCITING environment!

Cost: \$49.00 for (4) weeks, 1 hour per week
Classes Available Monday Thursday
SESSION 1: Begins June 17th
SESSION 2: Begins July 22nd

FOR AGES (6-9)

FOX CREEK G.C. (248) 471-3400
WHISPERING WILLOWS (248) 476-4493
IDYL WYLD G.C. (734) 464-6325

JUNIOR GOLF CAMPS
Available for Residents ages (10-17)
Must be 10 years of age by 6-17-02

1 SESSION = (3) 90 Min. Classes
Classes are limited to 20 participants
Cost \$69.00 per session.

WHISPERING WILLOWS G.C.
Each Session Begins at 8:30AM
SESSION 1 June 17th - 19th
SESSION 2 June 28th - 28th
Please call for more available dates

El Dorado COUNTRY CLUB
2869 N. Pontiac Trail
COMMERCE TOWNSHIP
- Public Welcome -
248/624-1050 EXT. 1

1st BUCKET FREE
Grass driving range and putting green. Present this coupon for any size bucket of range balls. One coupon per person, per visit. Expires 5-19-02. MS

FREE GOLF
Buy One Round of Golf & Get Second Round FREE!
SAVE UP TO \$45
Valid for 9 or 18 holes Walking and/or riding. Valid for open play anytime. Not valid w/any other discount or special. Expires 5 15 02 MS

JUNIOR GOLF LEAGUES
Available for Residents ages (10 - 17)
Must be 10 years of age by 6-19-02

BEGINNER LEVEL
Idyl Wyld G.C. (Mondays or Thursdays)
(5) 9 Hole Rounds and (1) Tournament Entry
Cost \$49.00 Begins June 20th

INTERMEDIATE LEVEL
Whispering Willows G.C. (Tuesdays)
(5) 9 Hole Rounds and (1) Tournament Entry
Cost \$59.00 Play begins June 25th

JUNIOR (Advanced) GOLF TOUR
Play all 3 Livonia Golf Courses (Wednesdays)
(5) 9 Hole Rounds and (1) Tourn. Entry & more!
Cost \$99.00 Play begins June 20th

Junior Golf Programs (except for SNAG GOLF) are only available for Livonia Junior Residents. Registration in person at Idyl Wyld G.C.: May 2nd, 4th or 5th, 2002

CITY OF LIVONIA GOLF DIVISION

PLEASE CALL US FOR MORE INFORMATION @ (248) 471-3400

PLAYER ASSISTANTS STARTERS & RANGERS

We are currently seeking individuals interested in being a part of our new volunteer Player Assistant Program for the 2002 golf season.

VOLUNTEER = FREE GOLF
Have an interest in golf?
- Are you kind and courteous?
- Like to carry a smile?
- Willingness to help others?
- Enjoy being outdoors?
Then this program is for you!

NEW

Tanglewood GOLF CLUB

GOLF SPECIAL

WEEKENDS After 12 Noon
18 Holes with cart \$50.00

WEEKENDS After 4:00pm
18 Holes with cart \$35.00

(248) 486-3355 EXT. 26

Free bucket of balls with coupon NOT VALID FOR OUTINGS

SPORTS ROUNDUP

SUMMER HOOP CAMPS

The Plymouth Canton/Plymouth Salem Girls Summer Basketball Camps are scheduled for June 17-21 and June 24-28 at the Canton HS gym

For girls entering the eighth and ninth grades this fall, the camp will be from 1-3 p.m. June 17-21. For girls entering the fourth, fifth, sixth and seventh grades this fall, the camp will be from 1-3 p.m. June 24-28.

Cost is \$65 per camp. Make checks payable to the Plymouth Canton Community Schools and send camp application to Community Education Dept., Starkweather Center, 550 N. Holbrook, Plymouth, MI, 48170.

For more information, call (734) 416-2937 or (734) 414-8156.

BASEBALL TRYOUTS

The Canton Cardinals 10-and-under travel baseball team, which will play 36 games in the Little Caesars League and various tournaments (including the state tournament), is having tryouts.

For tryout information, call Chris Tidwell at (734) 495-9767.

S'CRAFT VOLLEYBALL CAMPS

Schoolcraft College will offer a series of summer volleyball camps, directed by Ocelot

women's coach Tom Teeters, for players ages 8 through adult.

There will be two sessions for all skills, 9 a.m.-1 p.m. Monday through Friday, July 8-11 and July 15-18, spikers training, July 15-18, serving and defense training, July 8-11, setters training, July 15-18, and elite all skills, July 8-11.

The camps will be held at Schoolcraft's Physical Education Building, 18600 Haggerty Road, between Six and Seven Mile roads.

The cost for beginners and intermediate players for each session is \$90 (\$85 for each additional family member or groups of 10 or more).

A \$30 non-refundable deposit is required upon registration with full payment due on or before the first day of each session.

The cost for elite camps is \$125 (\$115 if registered by June 14, or for each additional family member or groups of 10 or more).

There is a \$10 discount for any additional session for beginners, intermediate or elite camp sessions.

For more information, call (734) 462-4400, Ext. 5564 or 5607.

S'CRAFT SOCCER SCHOOLS

Schoolcraft College will be

offering a series of summer soccer schools for boys and girls ages 5-16, 9 a.m. to noon, Monday through Friday, July 15-20, 22-27, July 29-Aug. 3, Aug. 5-10.

The staff is headed by Dominic Scicluna, head men's soccer coach at Schoolcraft, along with Mario and Tino Scicluna.

The cost for beginner and intermediate players is \$110 per session (\$100 for each additional family member or groups of 10 or more).

The fee for advanced players is \$135 per session (\$125 if registered by June 15 or for groups of 10 or more).

A \$50 non-refundable deposit is required per entrant with reg-

istration. Full payment is due on or before the first day of each session.

For more information, call (734) 462-4400, Ext. 5249 or 5255.

TAI CHI, YOGA GOLF

Schoolcraft College's Continuing Education Services is offering a seven-week yoga and Tai Chi class to improve your golf game beginning at 6 p.m. Wednesday, May 8.

The fee is \$60. The class examines the mechanics of your golf swing using components found in yoga, Tai Chi and martial arts, choreographed to music. It also includes improved timing, strength, visual and creative imaging while examining equipment, theory, and ways to develop critical thinking and discovering your swing.

Participants do not need equipment, but do need an open mind and positive attitude.

For more information, call (734) 462-4413.

Schoolcraft is located at 18600 Haggerty Road, located between Six and Seven Mile roads just west of I-275.

WOMEN'S SOCCER LEAGUE

The Great Lakes Women's Soccer League is seeking players for the outdoor season, Sunday evenings June through August, for 18-a-a-up competitive, 30-and-up competitive and recreational.

Teams or individuals, experienced or novice, are invited.

For more information, call (248) 624-7515 or fax (734) 207-1656, or visit www.GLWSL.com.

MEN'S BASEBALL LEAGUE

Players between the ages of 18 and 28 are needed for the new Men's Amateur Baseball League in southeast Michigan. Anyone interested in playing should contact Doug Zuba at 734-383-3402.

EMU YOUTH FOOTBALL CLINIC

The Eastern Michigan University football coaches will host a youth football clinic 1:30-4 p.m. Sunday, May 5, at Rynearson Stadium in Ypsilanti for kids ages 8 to 14.

Each participant will receive a T-shirt, two tickets to the home opener against Toledo on Sept. 7 and a tour of the team locker room and weight room.

The cost is \$15. All groups or teams of 10 or more will be charged \$10 a person.

The coaches, including head coach Jeff Woodruff, will teach basic skills and techniques to become an improved player. For more information call (734) 487-5642.

MS LONGEST DAY OF GOLF

The National Multiple Sclerosis Society is sponsoring the MS Longest Day of Golf throughout the month of May to raise awareness and funds to benefit the Michigan Chapter of the NMSS.

Participants are asked to organize a foursome, call the National MS Society at 1-800-FIGHT-MS or visit it online at www.nmssmi.org, pick a course and a day in May, register, raise pledges and get ready to play golf all day.

The event will raise money for research, programs and services for people living with MS, a chronic, often disabling disease of the central nervous system. More information call Amber Ackley at (248) 350-0020, ext. 215.

HOLOWICKI HOOP CAMP

Bernie Holowicki's All-Star Basketball Camp, for boys and girls ages 8-15, will begin June 9 at Madonna University.

There will be three sessions of boys camps, the first at 9 a.m.-3 p.m. June 9-13, the second at 9 a.m.-3 p.m. June 14-18, and the third at 9 a.m.-3 p.m. June 19-23. The cost for each is \$150.

The girls basketball camp will be July 10-14 at Madonna. Cost is \$140.

The camps will feature contests and prizes, a quality shirt for each participant, drills, camp awards, guest speakers, motivational and instructional videos, special games with the camp staff, a personal written evaluation, a camp championship tourney, and much more.

For further information or to register, call Bill Derderian at (313) 937-0966 or Madonna University coach Bernie Holowicki at (734) 261-3346 (home) or (734) 432-5591 (Madonna).

Anyone interested in submitting items to Sports Scene or Sports Roundup may send them to sports editor C.J. Risak, 36251 Schoolcraft, Livonia, MI 48150, or may FAX them to (734) 591-7279.

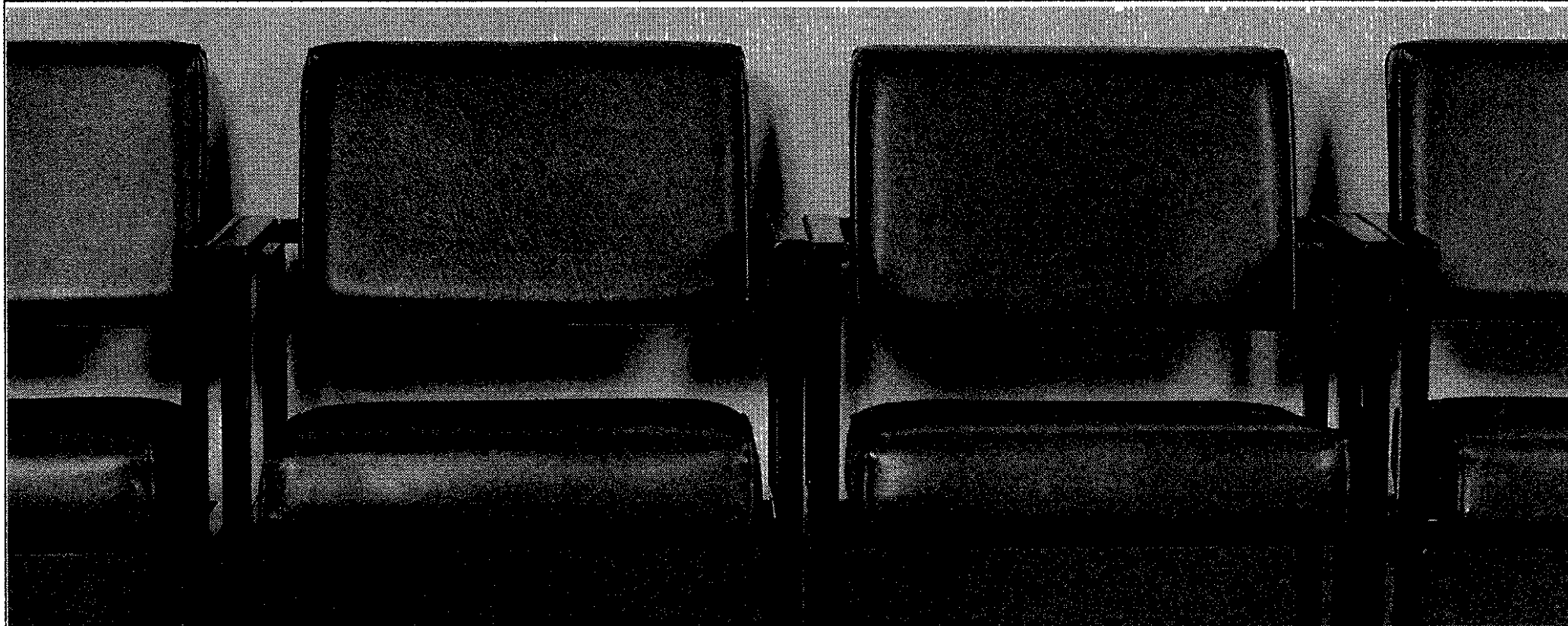

Of all modern medicine's advances,
the best may be the cure for the waiting room.

When you set foot in an Oakwood Emergency Room, we'll make sure you see a doctor in 30 minutes or less. Every location, every time. The 30-Minute Guarantee — another medical breakthrough from Oakwood. To find out more, visit www.oakwood.org.



Oakwood
Designed Around You™

Oakwood Annapolis Hospital — Wayne
Oakwood Healthcare Center — Canton

Chiefs from page D1

Tobin's first RBI single tied the game at 3-3 in the fifth. Andy Thackaberry's sacrifice fly put Salem up 4-3. The Rocks stretched their lead to 6-3 with run-scoring hits by Neil Kowalik and Tobin in the seventh.

Kevm O'Berne got the pitching win for Salem, with help from Boyer, who got the save.

In the second game, Rickey Calleja allowed one unearned run on two hits in five innings, but the Rocks stranded 10 baserunners in the loss. Kowalik gave up the winning run to the Titans in relief in the 6th inning.

Tobin had a single and a double for the Rocks, whose only run scored on a base hit by Kowalik.

Zoe Christian 6, Agape 3: Host Warren Zoe Christian took advantage of four errors by Canton Agape Christian to score three unearned runs Monday.

Agape fell to 5-3 with the loss. Zoe Christian is 6-1.

Jeremiah Belton had two hits and scored two runs to lead the

Wolverines. Rob Hough, Josh Anthony and Paul Chrenko each had run scoring singles. David Donaldson started and took the loss for Agape, giving up six runs (three earned) on six hits, four walks and one hit batsman, striking out four in four innings. The Wolverines played without short stop Mike Bommarito who's out indefinitely with a thumb injury.

Agape 4-8, Oakland Christian 5-7: A two run rally in the bottom of the fifth inning allowed host Auburn Hills Oakland Christian to edge Agape in the first game Saturday. In the second the Wolverines led 8-3 entering the bottom of the seventh inning then had to withstand a Lancers comeback that fell one run short.

In the first game, Rob Hough took the loss, giving up five earned runs on eight hits, three walks and a hit batsman, striking out nine. Hough had two hits in the game, including a solo home run in the fifth inning that trimmed Oakland Christian's lead to 4-3.

David Donaldson and Paul Chrenko each had two hits, Donaldson stealing two bases and Chrenko knocking in a run, and Josh Anthony had an RBI single.

In the second game, Anthony ran his record to 3-0, allowing seven runs (five earned) on six hits and four walks, striking out 15. He also paced the offense, collecting two hits, including a double, driving in three runs and scoring three more. Agape led 6-1 after two innings. Jeremiah Belton added two hits, including a double, and he scored three runs, Hough had a hit and three RBI, and Chrenko had an RBI single.

A.A. Greenhills 6, Agape 2: Four errors doomed Canton Agape Christian Tuesday against Ann Arbor Greenhills at Concordia College in Ann Arbor.

Rob Hough took the pitching loss for the Wolverines, allowing six runs (two earned) on five hits and two walks, striking out seven. Ben Herman got the win for Greenhills, allowing no runs on

three hits and three walks, fanning seven in five innings.

Agape scored both of its runs in the sixth inning without the benefit of a hit. Hough and Mike Ossana both walked, an error and a stolen base put them at second and third, with Hough scoring on Bobby Konrad's fielder's choice. The second run scored on a passed ball.

Josh Anthony had two hits for the Wolverines.

Catholic Central 9-3, Brother Rice 6-7: This storied rivalry resumed Saturday, and in the end little was settled between the two baseball powerhouses.

The Shamrocks split a Catholic League doubleheader with Birmingham Brother Rice, winning the first game 9-6 before dropping the second 7-3. Both teams have 7-1 records in league play, while CC stands at 11-2 overall.

The Warriors jumped out to a 4-0 lead in the first game, only to see CC rally from four run deficits twice. The Shamrocks batted around in the sixth inning to turn

a 6-2 deficit into a 6-6 tie game. That's when one of the team's youngest players stepped forward with one of his biggest hits of the season.

Sophomore Ryan Gallagher belted a three-run home run to finish the comeback and give CC the win. The team used pitching and defense to keep Brother Rice at bay in the seventh, getting a double play to end the game.

CC coach John Salter said he was impressed with Gallagher when he was on the freshman and JV teams last year, and has brought his smooth swing and hitting stroke up to the varsity level with no dropoff in his numbers.

"The big question was could he hit varsity pitching," Salter said. "He leads the team with 17 RBI and is hitting 471 with runners in scoring position. He's also doing a nice job defensively at catcher and first base."

Jeff Niemiec pitched all seven innings, getting the win with nine strikeouts and just three walks.

Salter said he was impressed with the way he could pitch out of early inning troubles to make enough pitches to help his team be in position to win.

Ryan Rogowski and Mike Monterey delivered RBI singles to start the second game, but the 2-0 lead couldn't hold up against a motivated Brother Rice team.

"We are definitely facing some teams who are playing well," Salter said. "We've had a busy stretch over the past week and half which will test your pitching. Now we have to win as many league games as we can until we face Brother Rice again (May 8)."

Monday, CC rallied from a late deficit to upend Wyandotte Roosevelt 6-5 in eight innings. The Shamrocks' comeback culminated on Jeff Niemiec's eighth inning sacrifice fly that scored Gallagher to win the game. Gallagher started the rally with a double and later advanced to third on a wild pitch.

Read Arts & Entertainment for what's happening around town

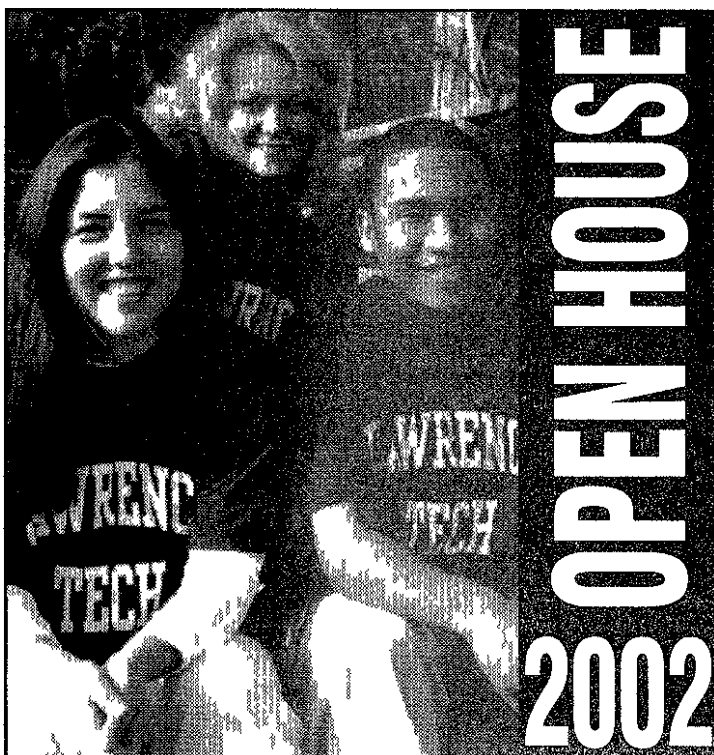

Sat., April 27 noon - 5 p.m.
Sun., April 28 noon - 3 p.m.

Hundreds of special displays and demonstrations by students in architecture and design, arts and sciences, engineering, management and technology

- Campus Tours
- Concept Cars
- Admissions, financial aid and housing information
- Free and open to the public

LAWRENCE
TECHNOLOGICAL
UNIVERSITY

21000 W Ten Mile Rd at Northwestern Hwy
Southfield MI 48075

1 800 CALL LTU
www.ltu.edu

INDOOR WEATHER TEAM

28TH YEAR

Carrier, 100 Years of Innovation. 100 summers ago, when everybody was talking about how hot it was, Willis Carrier was doing something about it. Inventing air conditioning. This would make it possible for you to enjoy year round ideal comfort, right in your own home.

www.carrier.com

UNITED TEMPERATURE
HEATING & COOLING
734-525-1930
8919 Middlebelt • Livonia

ATTENTION: MEDICAID ENROLLEES

For over 18 years, Midwest Health Plan has offered health care to Medicaid members



You May Choose From Over 500 Primary Care Physicians in Wayne, Oakland, Macomb & Washtenaw Counties.

OPEN ENROLLMENT STARTS IN MAY

TO ENROLL CALL: MI-Enrolls 1-888-367-6557



YOU HAVE ARRIVED

HOME GARDEN

THE 2002 HOME AND GARDEN SHOW

APRIL 20 - MAY 12 • NORTH GRAND COURT
BIRDBHOUSE AUCTION • MAY 11 AT 7PM • BENEFITS THE DETROIT ZOO



DOMINICK TRINGALI ARCHITECTS



Fresh flowers. Manicured gardens. Miniature houses. More than one hundred handmade birdhouses designed by critically acclaimed area architects and builders will be auctioned off to benefit the Detroit Zoo on Saturday, May 11th at 7pm. Like everything else we do, the birdhouses will be unlike anything you've ever seen before. Just make sure you don't miss them before they end up in someone else's backyard. The Home and Garden Show at Somerset Collection. You have arrived.

SOMERSET COLLECTION

NEIMAN MARCUS SAKS FIFTH AVENUE NORDSTROM MARSHALL FIELD'S AND MORE THAN 180 OTHER UNIQUE SHOPS AND RESTAURANTS FOR MORE INFO LOGON TO WWW.THE-SOMERSETCOLLECTION.COM

B1106798

charitysale

Parisian presents a morning of special savings, a \$1000.00 shopping spree giveaway for one lucky shopper and more to benefit local charities and schools.

For more details, see your local Parisian store manager.

Ticket holder receives **20% off** all* purchases Saturday, April 27 6:00 am to 10:00 am

Tickets \$5.00

Children under 12 admitted free with parent

*10% OFF SMALL ELECTRICS. EXCLUDES GREAT BUYS AND WATCHES IN ERIC JEWELRY FRAGRANCES, COSMETICS, BRIGHTON, LILLY PUZZLER, TOMMY BAHAMA, ROBERT TALBOTT, FRESHWICK & MOORE DRESS SHIRTS, NAUTICA, LACOSTE, AVIS, GIBSON BRIDG, LEVY'S, HEBBELL, AUBACE, SPANX, KATE SPADE, COLE HAAN, DONALD J. PLINER AND STUART WEITZMAN. CANNOT BE COMBINED WITH ANY OTHER COUPONS. CAN NOT BE USED ON PREVIOUSLY PURCHASED ITEMS. PRESENT YOUR CHARITY SALE TICKET EVERY TIME YOU MAKE A PURCHASE TO RECEIVE YOUR DISCOUNT.

- participants
- Plymouth Salem High School East Middle School
 - Franklin High School
 - Marywood Nursing Center
 - Harvest of Hope Habitat for Humanity
 - Oakwood Home Care Services
 - Adult Well-Being Services
 - Community Living Services
 - Our Lady of Good Counsel
 - St Genevieve Women's Sodality
 - Riverside Skate Club
 - Caregivers Hope
 - United Methodist Church
 - Farmington AAUW
 - Livonia AAUW
 - Samaritan Counseling Center
 - Stevenson Middle School
 - St James Self Help Program
 - Savage Elementary School
 - Holmes Middle School
 - Latinos de Livonia
 - Grandview Elementary School
 - South Oakland Shelter
 - Divine Savior Church
 - Agape Christian Academy
 - New Hope Center of Grief Support
 - New Metro Detroit Club of the National Association of Negro Business and Professional Women
 - Nankin Mills Elementary School
 - Hull Elementary School
 - Jude Missionary Baptist Church
 - St Edith's Catholic School
 - Cooper Elementary School
 - Matrix Human Services
 - Detroit Urban League
 - Livonia YMCA
 - SSS Ravinica Choir
 - Housing for Exceptional People—Burgess
 - Hoover Elementary School
 - Volunteers of America
 - Taylor Elementary School
 - Novi Lioness Club
 - HEP Burgess Cooper Elementary School
 - Johnson Elementary School

15% OFF your 1st day's purchases when you open a Parisian credit account and use it. Subject to credit approval. See an associate for details.

PARISIAN

YOU'RE SOMEBODY SPECIAL

PDF L1105245

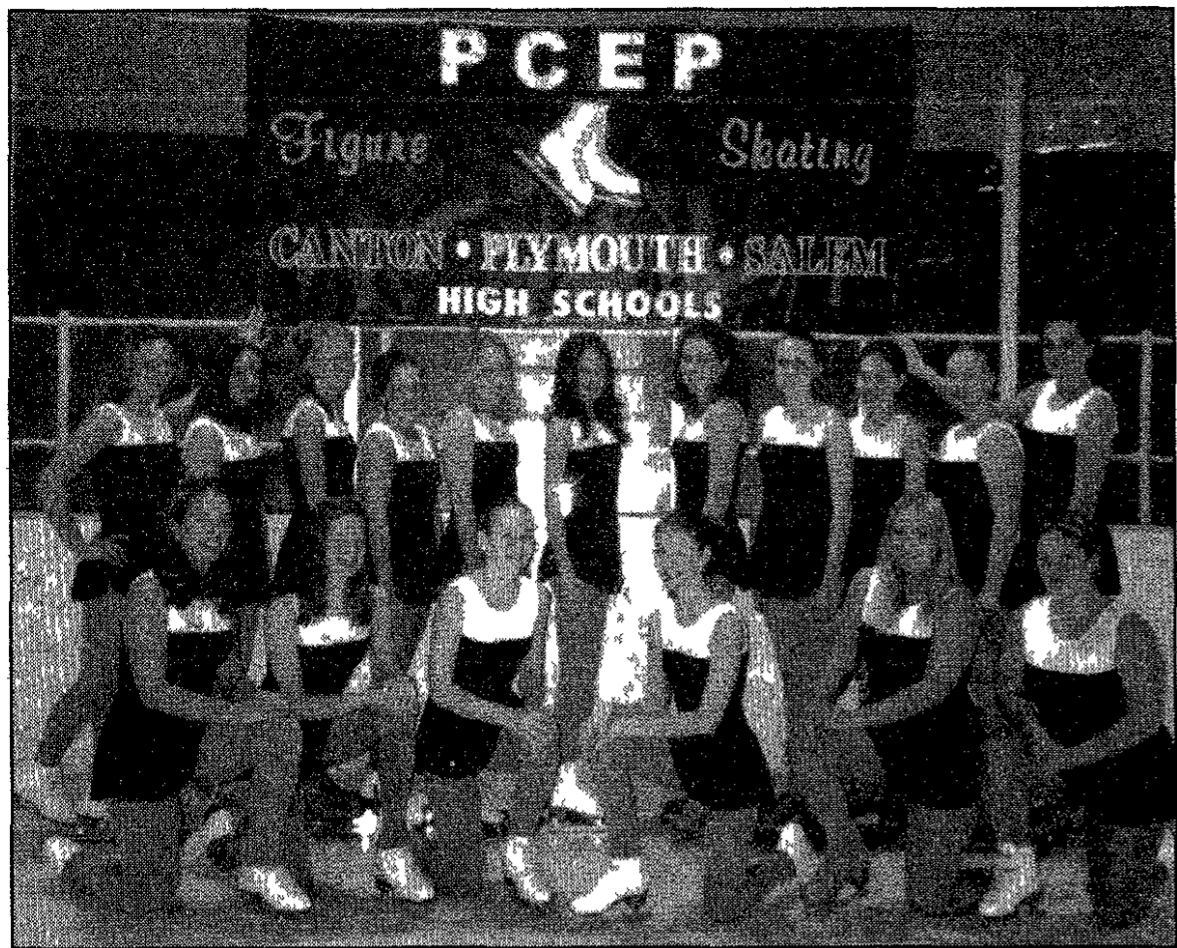

Skating team: The Plymouth-Canton Educational Park figure skating team. Team members are Mary Baj, Lauren Frawley, Lauren French, Laura Friedman, Sarah Forster, Jenni Hotycki, Nichole Johnson, Renae Kolarik, Lauren Lippert, Monica Lippert, Michelle Manery, Claudia Molier, Christin Nycek, Jessica Pavelka, Whitney Pieknik and Jessica Williams. The team is coached by Barb Miller.

PCEP from page D1

their school? Which is all they wanted. As Kolarik explained, "To have an opportunity to represent their school." Indeed, being a figure skater can confine a high school athlete. "The biggest thing about having a high school team," explained Miller, "is that skaters usually can't be part of other high school sports. They put so many hours into skating, they don't have the chance." What this sport has done — with just 32 schools statewide involved, figure skating is far

below the number needed to be considered an MHSAA sanctioned sport — has replaced the 'me' of figure skating with 'we'. "It's a team event," noted Miller. "Some of the skaters have really come out of their shell. There's not as much pressure (in the team concept) as in the other." Can figure skating reach enough of an audience to become a sanctioned sport? That's difficult to predict, but certainly Michigan may be the place for it to flourish. Team figure skating got its start in

Massachusetts six years ago, it's been in Michigan for four years. But Michigan has the highest number of schools with teams. At PCEP, the outlook for the future is bright. A seventh-place finish at state by the Local Team helped assure that "Next year will be much better because kids will move up (a division)," said Miller. "And we have a couple of real strong skaters coming to the high school that will help the team." Sounds promising, all the way around.

Read The Observer for local news

Congratulations... FOR FLYING THE RED, WHITE AND BLUE!

Bring in your picture and you could win \$50 towards any floor covering purchase between \$499-\$999 or \$100 off any floor covering purchased over \$1000

This Week's winner...

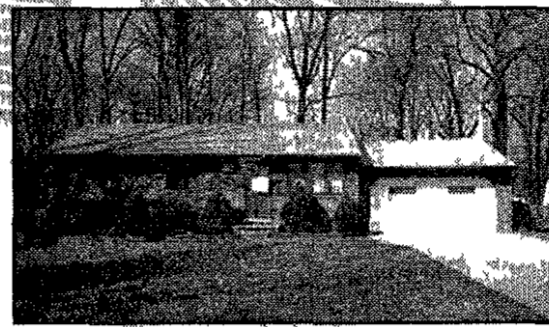

You could WIN A *Congoleum* FLOOR of your choice. Like our new Utopia collection or our durable ULTIMA series. Come into our store for more details!

37530 Grantland, Livonia

Also... When you bring in your picture, you will automatically be eligible for a drawing to win a FREE *Congoleum* Floor (120 sq. ft.) to be held September 2002. Keep looking in the paper to see if we pick your house

INDEPENDENT CARPET ONE

1400 N. Wayne Road • Westland, MI 48185
734.729.6200 Fax 734.729.4162
Hours Sunday 12-4, Mon-Fri 9-9, Sat. 9-6
www.carpetone.com

Observer Classifieds sell!

Get the picture!
Order a photo reprint

Send us your order for a picture that has appeared in your hometown newspaper. It's easy. Just tear the page on which the picture appears out of your newspaper, fill in the form below and send us both along with your check or credit card information.

Note: Request will take three to four weeks to process and the photo must have been taken by one of our "staff photographers" within the last six months. We will reproduce your photo as accurately to the newspaper photo as possible, however, reproduction colors may vary. The inks to print the newspaper and the emulsion to print on photo paper are different. We regret refunds are not possible with photo orders due to color variations.

CUSTOMER INFORMATION

NAME _____
ADDRESS _____
CITY _____ STATE _____ ZIP _____
DAYTIME PHONE _____

REPRINT INFORMATION

EDITION NAME (Which Observer or Eccentric) _____
EDITION DATE _____
SECTION AND PAGE NUMBER _____
DESCRIPTION OF PHOTO _____

PAYMENT INFORMATION

ONE PHOTO REPRINT @ \$20 \$ _____
ADDITIONAL REPRINTS of SAME PHOTO @ \$7.50 EACH \$ _____
TOTAL AMOUNT OF ORDER \$ _____

Visa MasterCard Discover American Express

Charge Card # _____ Expiration Date _____

Mail to **Observer & Eccentric**
NEWSPAPERS
Attention: PHOTO REPRINTS c/o Jane Garner
36251 Schoolcraft Road, Livonia, MI 48150

Off to a great start.

How long has Showroom of Elegance Fine Jewelers been in business?
One year and three months.

How long have they been advertising in The Observer & Eccentric Newspapers?
One year and three months.

When we asked Linda Robin, owner of Showroom of Elegance, why she's stayed with us, she explained, "We reach our target customers at an affordable cost."
"We have had excellent results from our ads and many customers have told us they came in because they learned about us in The Observer & Eccentric."
"That has been vital for a new business."

We can introduce customers to you, too!

THE Observer & Eccentric
NEWSPAPERS
It's all about RESULTS!

Wayne County 734-953-2153 • FAX 734-953-2121
Oakland County—248-901-2500 • FAX 248-901-2553 • Rochester 248-651-7575 • FAX 248-651-9080
Lake Orion 248-693-4900 • FAX 248-693-9716 • Clarkston 248-625-1900 • FAX 248-625-5712

Young players stepping up for Crusaders

The Madonna University softball team continues to battle, defying its lack of experience. The Lady Crusaders entered the season with one senior and one junior on their roster which meant coach Al White would be forced to rely heavily upon his younger players.

They've come through like veterans. Led by the steady pitching of their two upperclassmen — senior Missy VanDoorn and junior Jenny Tenyer — the Crusaders have managed to stay in the chase in the Wolverine Hoosier Athletic Conference.

On Tuesday at Livonia Ladywood, Madonna handcuffed Spring Arbor, allowing just one run and six hits in two games. But the Crusaders could only manage a split, losing the opener 1-0, before winning the second game with an 11-0 mercy.

The split left Madonna with an 11-11 record in the WHAC, 19-21 overall. Spring Arbor is 16-12 in the conference, 21-25 overall.

Through Tuesday, Cornerstone led the WHAC with a 16-5 mark. However, the second-through-sixth spots were bunched. Aquinas is second only 2-5 games ahead of sixth place Madonna.

VanDoorn absorbed the hard luck loss in the first game against the Cougars. She tossed a five-hitter, giving up one earned run, issuing four walks while striking out two, her record is 12-9. Spring Arbor's Holly Davidson was even better, however, stopping the Crusaders on three hits and four walks, striking out three.

In the second game, it was Tenyer's turn to step forward — and she did, frustrating the Cougars with a one-hit gem. Tenyer did not walk a batter in her five innings on the

COLLEGE SOFTBALL

ground striking out two as she improved to 7-12.

Bobrowski had two hits to lead the offense, including a home run (her sixth), and three runs batted in. Tara Turner contributed two hits (including a double), two runs scored and two RBI, and both Kathy Day (from Livonia Ladywood) and Krystle Shina (from Farmington Mercy) had a hit and two RBI.

Last Saturday at Ladywood HS, Madonna and Tri State University divided their WHAC double header. Tri State winning the opener 5-4 and Madonna gaining the victory in the second game 9-4.

The fifth place Thunder won the first game Saturday thanks to eight Crusader errors. All five runs allowed by Tenyer, who took the loss, were unearned. She gave up nine hits and no walks in 6 1/3 innings.

Offensively, Bobrowski had a triple and a single with two runs batted in and Autumn Batyuk had two hits and scored two runs. Turner also had a hit and an RBI.

Madonna led 3-0 after four innings, but gave up five runs in the next two.

In the second game, VanDoorn benefitted from an 11-hit Madonna attack, allowing four runs (one earned) on 11 hits and three walks, striking out four.

The Crusaders scored eight runs in the first two innings to take command. Bobrowski again led the offense, collecting two hits including a home run and three RBI. Arin

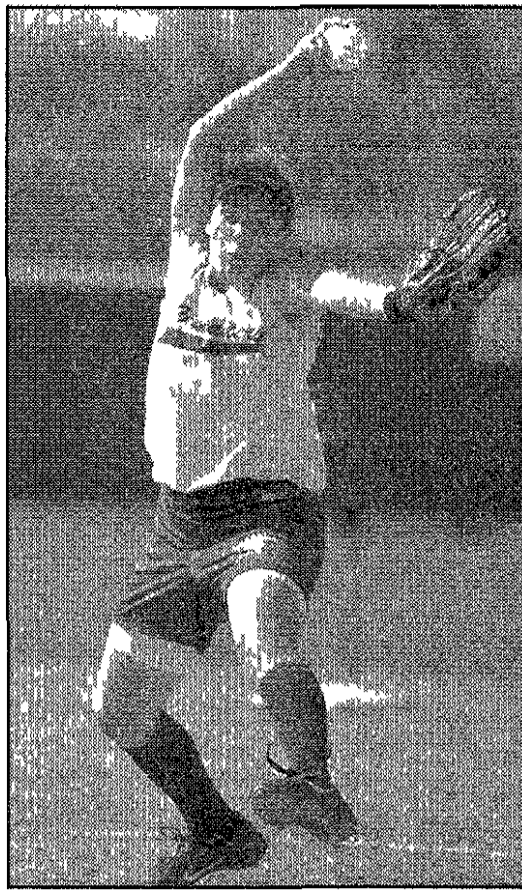

STAFF PHOTO BY BRYAN MITCHELL

Let it rip Madonna pitcher Jennifer Tenyer has been on top of her game lately, throwing a 1-hit shutout Tuesday in the team's win over Spring Arbor.

Fowler added three hits (including a double), two runs scored and an RBI. Shina had two hits including a solo homer and two runs scored. Tenyer had two hits and an RBI, and Mary Warchuck had a hit and two RBI.

Madonna plays at Cornerstone University Friday, then hosts Indiana Tech Saturday.

MU baseball having up and down season

BY C.J. RISAK
STAFF WRITER
cjrisk@oe.homecomm.net

COLLEGE BASEBALL

In all phases of the game, this has been an odd season for Madonna University's baseball team.

A week ago, the Fighting Crusaders scored 11 runs in a non-league game against Bethel College, leading 9-4 at one point — and lost, 16-11. Three errors in one inning fueled Bethel's comeback victory.

Not that the offense has sparkled all season, either. Remember the no-hit double-header Madonna suffered at Indiana Tech that led to it being mentioned in Sports Illustrated?

Through Sunday, the Crusaders had played 34 games, some very good, some pretty bad. Against Concordia College Sunday at Livonia's Ford Field, Madonna did what it was supposed to do. It swept the weakest team in the Wolverine-Hoosier Athletic Conference, shutting out the Cardinals twice, 2-0 and 4-0.

Madonna moved over the 500 level in the WHAC at 9-8, its overall record is 16-18. Concordia is 7-35 overall, 1-17 in the conference.

Chris Woodruff (from Livonia/Redford Catholic Central) and Joe Pruchnik (Lutheran Westland) each had two hits for the Crusaders in the opener to support the four-hit pitching of Jeremy Stevens. Stevens did not walk a batter, striking out one in six innings as he improved to 3-0. Adam Kline (Catholic Central) pitched a perfect final inning to pick up his fifth save.

Eric Lightle (Livonia Churchill) added a run-scoring single for Madonna.

As tough as Stevens was in the opener, Joel Halliday (Redford Union) was even better in the nightcap, handcuffing the Cardinals on two hits and no walks while striking out 10 in seven innings. Halliday improved to 3-2.

Woodruff again led the attack with two hits, including a double, and three runs batted in. Brian Williams (Livonia/CC) also had two hits.

With final exams this week, Madonna is not scheduled to play again until Saturday when it hosts WHAC rival Tri-State in a 1 p.m. double-header at Ford Field.

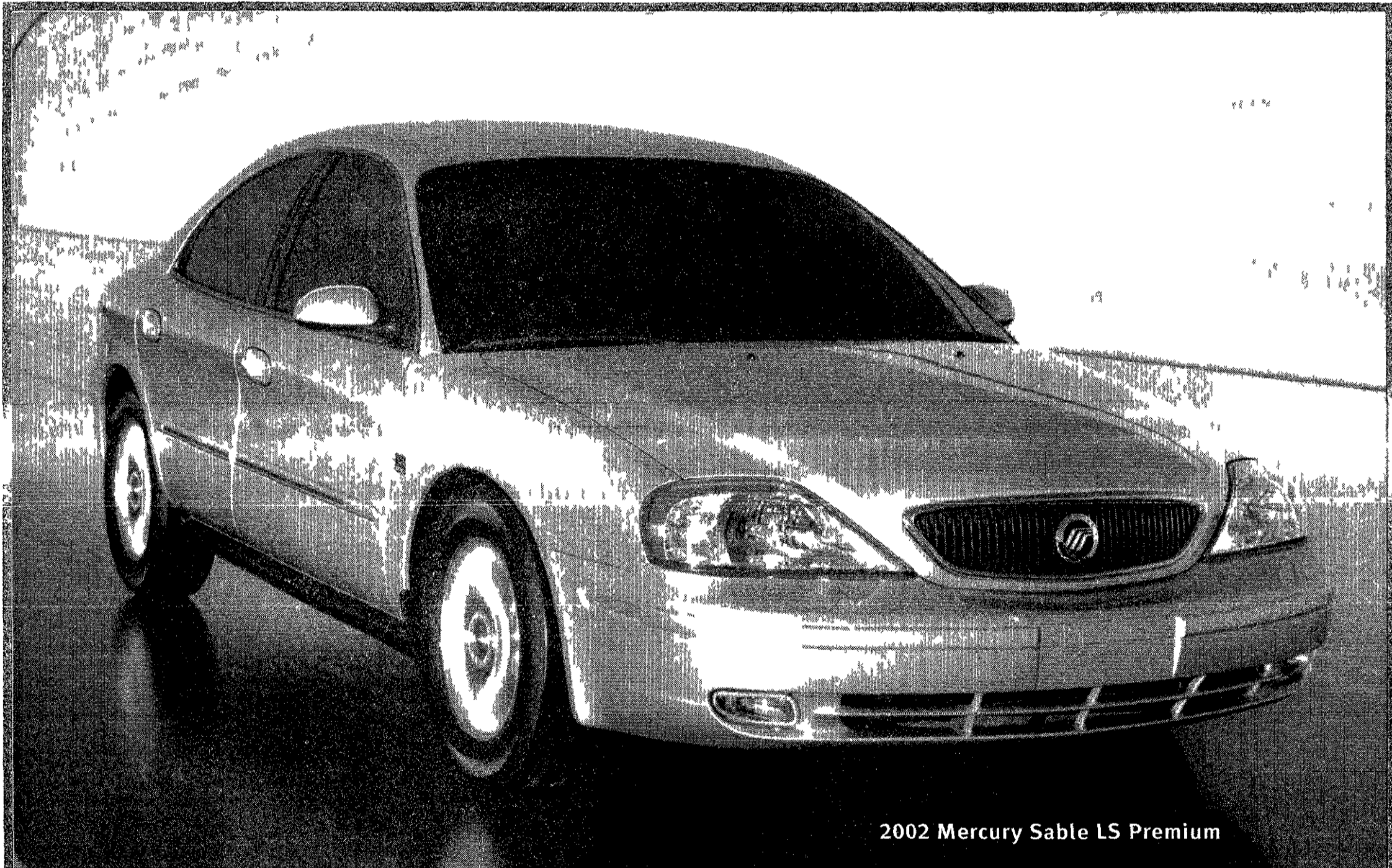

2002 Mercury Sable LS Premium

WITH ALL ITS STANDARD FEATURES, IT'S ANYTHING BUT STANDARD.

2002 MERCURY SABLE LS PREMIUM

- 200-hp V-6 engine
- Power-adjustable foot pedals
- Dual-stage front airbags*
- No-charge leather seating surfaces
- No-charge ABS
- Double Five-Star Crash Test Rating



FOR A/Z/D-PLAN EMPLOYEE & ELIGIBLE FAMILY MEMBERS

\$269 PER MONTH/
36-MONTH LEASE
FOR RETURNING LESSEES

CASH DUE AT SIGNING **\$1,219****
(AFTER \$3,000 CASH BACK)

INCLUDES REFUNDABLE SECURITY DEPOSIT EXCLUDES TAX, TITLE AND LICENSE FEES

\$2,000 CUSTOMER CASH OR **0.0% APR***** LIMITED-TERM FINANCING

For latest offers go to LMAplan.com



MERCURY

Visit Your
Metro Detroit
Mercury Dealer

ANN ARBOR
Sesi
2100 W Stadium Blvd
at L bertly
(734) 668 6100
sesilm.com

CLINTON TOWNSHIP
Stu Evans Lakeside
17500 Hall Rd
at Romeo Plank
(586) 840 2000
stuevanslakeside.com

DEARBORN
Jack Demmer
21531 Michigan Ave
Between Southfield & Telegaph
(313) 274 8800
demme1m.com

DETROIT
16901 Mack Ave
at Cad euz
(313) 885 4000
bobmaxeyim.com

DETROIT
Park Motor
18100 Woodward Ave
Opposite Palmer Park
(313) 869 5000
parkmotorsim.com

GARDEN CITY
Stu Evans Garden City
32000 Ford Rd
Just West of Merriman
(734) 425 4300
stuevansgardencity.com

NOVI
Varsity
49251 Grand River
1/6 at Woxon Rd (Ext 159)
Two Ex ts West of 12 Oaks Mall
1 800 850 NOVI (6684)
varsityim.com

PLYMOUTH
Hines Park
40601 Ann Arbor Rd
at I 275
1 800 550 MERC
hinesparkim.com

ROCHESTER HILLS
Crisman
1185 South Rochester Rd
Between Hamlin & Avon Rd
(248) 652 4200
crismanim.com

ROSEVILLE
Bob Maxey
29000 Gratiot
at 12 Mile Rd
(586) 552 6000
bobmaxeyim.com

SOUTHFIELD
Star
24350 West 12 Mile Rd
at Telegraph
(248) 354 4900
starim.com

SOUTHGATE
Southgate
16800 Fort Street
at Pennsylvania
(734) 285 8800
southgateincolinmercury.com

STERLING HEIGHTS
Crest
36200 Van Dyke
at 15 1/2 Mile Rd
(586) 939 6000
crestlinmerc.com

TROY
Bob Borst
1950 West Maple
Troy Motor Mall
(248) 643 6600
borstim.com

YPSILANTI
Sesi
950 East Michigan
9 Miles West of I 275
(734) 482 7133
sesilm.com

*Driver and passenger front crash test **Call 1-888-56-LEASE for details. For cash back and special lease terms, take delivery from dealer stock by 5/1/2002 ***Not all buyers will qualify for Ford Credit financing For cash back or APR, take delivery from dealer stock by 5/1/2002 See dealer for details †Always wear your safety belt and secure children in the rear seat

REAL ESTATE

Thursday, April 25, 2002

Fix problem of incorrect assessment square feet

We have just learned that several of our members had the amount of their square footage listed incorrectly in their master deed. They're concerned about seeking reimbursement for their assessments since they've been paying for a larger number of square feet over the years. What should we do?

While obviously the association has a responsibility to correct the error, assuming that the assessments were based upon the percentage of value determined by square footage, the co-owner may have a sympathetic cause for reimbursement.

However, in a recent Tennessee case on similar facts, the court said that even if the math used in determining the proportionate share was flawed, the member in that case, who had lived there for 20 years, had notice of it when she bought before and had to pay what is required.

While there is no guarantee of that result in Michigan, it is at least a basis for you to start over again doing right without any readjustment for past errors.

Robert M. Meisner, a lawyer, concentrates his practice in the areas of condominiums, real estate, corporate law and litigation. This column provides general information and shouldn't be construed as legal advice.



ROBERT M. MEISNER

- ### HOME SEEKER'S CHECK LIST
- SELLER DISCLOSURE STATEMENT (REQUIRED BY LAW)
 - LEAD DISCLOSURE STATEMENT (REQUIRED BY LAW)
 - HOME SUMMARY FEATURE SHEET (ROOM DIMENSIONS, ETC)
 - SCHOOL DISTRICT SERVING NEIGHBORHOOD (WHERE EXACTLY ARE BUILDINGS BUS STOPS)
 - AGE OF MAJOR MECHANICAL/STRUCTURAL COMPONENTS (FURNACE, WATER HEATER, SHINGLES, WINDOWS, ETC)
 - APPLIANCES INCLUDED?
 - PROPERTY TAXES (BASED ON SELLING PRICE, NOT CURRENT RECORDS)
 - MUNICIPAL SERVICES PROVIDED (TRASH COLLECTION, LEAF PICK UP, SNOW REMOVAL, LIBRARY)
 - CONDITION OF NEIGHBORING PROPERTIES



Realtors find they can't constantly run at breakneck speed and succeed

BY DOUG FUNKE
STAFF WRITER
dfunke@oe.homecomm.net

Most real estate professionals know they can't be like Wonder Woman or Superman and perform at full throttle day in and day out over an extended period of time. "Sometimes we try, but it doesn't seem to work," said Gary Jones, broker/owner of RE/MAX Village Professionals in Bloomfield Hills, Rochester Hills and Clarkston. Burnout awaits those who don't or won't develop interests beyond the next deal. "If you get stressed out, you don't do your clients any good," said Joan Bessinger, a Realtor with Prudential Chamberlain Stehl in Farmington Hills. Experienced agents find that a hobby, activity or avocation can keep the personal/business life balanced, the grind manageable. Jones, long involved in community theater before getting into real estate 13 years ago, is active with St. Dunstan's Guild in Bloomfield Hills. He's always enjoyed theater since

taking a drama class as a kid. Now, he finds the experience relaxing, the social aspects rewarding. "Being on stage, directing, takes a lot of time," Jones said. "Since I've been in real estate I'm more behind the scenes - stage managing changing sets whatever needs to be done. Real estate, of course, is a people business," he added. "It can be pretty intense sometimes. At the end of the day, if you don't have something else to do, something else to think about, you might not be able to relax until the wee hours of the morning," Jones said. Which doesn't exactly make for a smooth-running human machine. "As I'm speaking to you, I just finished working out and that's so important," said Carol Eisenshtadt, a Realtor with Max Broock in West Bloomfield and a 20-year real estate veteran. "Working out gives me energy and increases my ability to endure the hours of work of a Realtor. I feel healthier and stronger physically and mentally," she said.

Eisenshtadt works out five days a week and substitutes golf one morning a week during summer. "And my clients know it," she said. "Your whole life cannot be real estate," Eisenshtadt added. "Real estate can be consuming, 29 hours a day, nine days a week. You have to have your own life some outside interest." You won't get any argument on that from Bessinger. "You have to take a little break now and then," she said. "With deals that have a lot of difficulty, you have to step back for a day or so, remove yourself from the situation. When you come back, you're clear." Bessinger's mini-break priorities - "take care of grandkids, cooking, going to casinos." On a more regular basis she's involved in church activities. Nadine and Jerry Henderson, a husband-and-wife team affiliated with Quality GMAC in Livonia, have been in business a combined 32 years. "You have to have other interests," Jerry said. "You just have to get away from it. You get stale. You really do." "We play golf and I go hunting and fishing. We both do a lot of gardening, get outside and breathe fresh air," he added.

Please see REALTORS, E2

Volunteers help educate homebuyers

An ancient proverb states, "When the student is ready, the teacher appears." As a military instructor pilot, I always knew which of my fledglings would excel. How? Their thirst for knowledge had them "hanging around" before briefings, talking after business hours, and even monitoring other students' flight debriefs.



TIM 'TIMBO' PHILLIPS

This type of mentorship extends into other facets of life, including your family's fiscal planning. In his best-selling book, *Rich Dad, Poor Dad*, author Robert Kiyosaki admonishes his readers to choose reliable sources of financial information. The idea is that you can listen to "broke" people or to rich people, depending on the results you wish to achieve.

It is difficult to find disinterested sources for mortgage information because the industry is profit-based. However, one not-for-profit organization - the Michigan Mortgage Lenders Association (MMLA) - has set the stage for hundreds of potential homebuyers in southeastern Michigan to gain invaluable insights into the otherwise bewildering matrix of home finance.

On Saturday, April 27, the MMLA will host the "Homebuyer Education Event 2002" at the University of Detroit Mercy's Calihan Hall from 9 a.m. until 2 p.m. The event, which is free, and open to the public, is the first of six to be held this year in Michigan, and the only one in the city of Detroit.

"Is there a chance that I can qualify for a home on my income? Should I consider using a Realtor? Why do I need a Title Insurance policy? What steps can I take to repair an old credit blemish? Can I buy a home if I am a Resident Alien? What is PMI and why must I pay it?" If you don't ask the questions, you will probably never know.

This year's Homebuyer Education Event will include a series of roundtable discussions with volunteer appraisers, home inspectors, lenders, title companies, and private mortgage insurers. Participants will have access to U of D concession stands, and may even have a chance to meet WJLB radio personalities. For more information or directions, call (248) 356-6857 during business hours.

For free e-newsletters, credit assessments or mortgage pre-qualifications, go to www.vlender.com /p /phillipshq or call (734) 797-5522 [24 hours]. Tim Phillips is a mortgage loan officer serving all of Michigan. Homebuyers should always consult a professional for guidance specific to their situation.

BY REGION		
LOCATION	PERMITS	PERCENT
NEW ENGLAND	43,000	2%
MID-ATLANTIC	112,000	-4
GREAT LAKES	226,000	+1
PLAINS	98,000	+3
SOUTH ATLANTIC	462,000	+4
EA/SO CENTRAL	79,000	-5
WE/SO CENTRAL	185,000	+5
MOUNTAIN	194,000	+4
PACIFIC	212,000	N/C
U.S.	1.6 MILLION	+2

Source: U.S. HOUSING MARKETS
RANDALL MASTERS/STAFF ARTIST

Realtor Bill Deacon hit apex as professional, friend

BY DOUG FUNKE
STAFF WRITER
dfunke@oe.homecomm.net

Colleagues and friends of William P. Deacon remember him as a dynamic real estate professional and person. "Bill's career as a Realtor included many years as a salesman followed by years as a highly successful manager, sharing the benefits of his experience with other agents," said Carol Frick, manager of Ralph Manuel Associates-Real Estate One in Birmingham. "Bill's career was one of leadership, of encouraging

others to do their best, of enabling us all to see visions of ourselves that we couldn't see on our own and helping us to get there," Frick added. Mr. Deacon, a former president of the Michigan Association of Realtors, the Western Wayne Oakland County Association of Realtors and the Dearborn Association of Realtors, died April 14. He was 66 and a Waterford resident. A memorial service was held Saturday, April 20. "Bill had a wonderful gift of being to each individual person exactly what that person needed," recalled Harry Smith, partner at Midtown Mortgage in Birmingham.

"He was kindhearted, loyal, hard-working, gentle. He was a good, caring man," Smith said. Most recently, Mr. Deacon was manager of the Century 21 Hallmark West office in White Lake Township. "He was the best in giving up his time endlessly for the betterment of the real estate business and to make the real estate business as professional as it possibly could be," said Bill Mountain, broker/owner there.

Please see DEACON, E2

Realtor Full Page Ad Index

Realtor	Page#
Century 21 Town & Country	8E
Coldwell Banker Preferred	3E
Real Estate One	1F

For the Best Home Buys in your Hometown Check the Sunday and Thursday Real Estate Section

HOME Of The WEEK

DOWNTOWN PLYMOUTH



is home for this beautifully updated 4 bedroom character home and where you can relax on your 23x15 covered front porch! The interior's a 10+ with 9' 1st floor ceilings, arched doorways, exposed hardwood floors, focal point wood staircase and classic windows. Updated oak kitchen and 2 full baths. Cathedral master with 2 skylites, huge walk-in closet and access to a skylit fashion bath with jetted tub. 2 car garage.

\$349,900

Call Mike & Mary Gladchun
RE/MAX on the trail 734.459.1234



Deacon from page E1

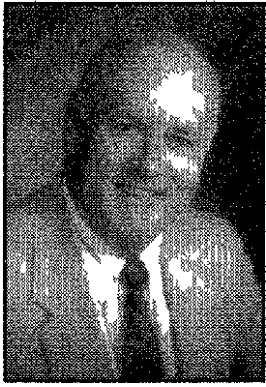

William Deacon

"He was probably one of the nicest gentlemen I've ever met," Mountain added "He was always upbeat He was a great guy"

Mr Deacon was a proud member of Alcoholics Anonymous, friends recalled, and served as a director of Sobriety House, a treatment center He also was a US Army veteran

Survivors include wife, Linda Winters Deacon, sons Stewart (Terese) of Virginia, Steven (Mary Carmen) of Mexico and

"He was probably one of the nicest gentlemen I've ever met."

Bill Mountain
— Century 21 Hallmark West

Kevin of Milford, and three grandchildren, William, Darlene and Tony

Memorials were suggested to the American Cancer Society or

Realtors from page E1

The latter can be a real pick-me-up after spending long days in and out of houses, cars and the office, Jerry conceded

"I write and I read a lot," said Adeline Blair, a Realtor with Coldwell Banker Legacy in Westland, who has started to slow down after nearly 32 years in the business

"I never felt work was full of pressure, but there were times when deals didn't go as easily as others," she said

Blair said she's written upward of 1,000 song lyrics, but none has

been published But that's OK with her

"I feel I have some good ideas and good thoughts to pass on," Blair said "I don't desperately sit and try to write It comes naturally"

And, yes, the creative process of writing sometimes parallels what happens putting things together in real estate sales, she added

Mary Donoghue, a Realtor with Jack Christenson in Lake Orion, learned early in her career to treat her personal life as an appointment

"If you don't, other appointments will take over and you won't have any time for yourself," she said "It becomes real evident as soon as you get busy"

Donoghue actually inputs away-from-work activities in her Palm Pilot

"I enter Sunday morning church appointment, my golf league appointment and visit-the-kids appointments," she said "If I do that, it will happen You just turn off the pager and silence the cell phone for a couple of hours"

MOVERS AND SHAKERS

This column highlights promotions, transfers, hirings, awards won and other news within the real estate, construction, architecture and mortgage communities

Send a brief summary including town of residency and black and white photo to Real Estate Movers and Shakers, Observer & Eccentric Newspapers, 36251 Schoolcraft, Livonia, 48150

Our fax number is (734) 591-7279

Four Realtors join the sales team at Coldwell Banker Schweitzer in Clarkston

Julie Alexander, a six-year veteran, lives in Clarkston She

holds the professional designation of Certified Construction Resource and a bachelor of science degree from Oakland University

Linda Walsh-Lapinski, licensed since 1991, holds the Graduate Realtor Institute designation and resides in Clarkston

Bryan Peters, an associate broker, lives in Auburn Hills and, has been a Realtor for eight years

Sandy Dubre, a Clarkston resident, has been licensed since 1996

Colliers International, a commercial brokerage in Bingham Farms, announces two hires

Wayne Robert rejoins the firm as vice president/ associate broker in the industrial brokerage group He's a 17-year veteran and lives in Brighton

Robert will handle sales and leasing of properties in the western suburbs including the I-275 corridor

James Soltis joins as associate broker in the office brokerage group He's a 28-year veteran who will be responsible for leasing, acquisition, disposition, strategic planning and market

evaluation
Soltis has a bachelor's degree from John Carroll (Cleveland) University and lives in Brighton

John E. Enkemann Jr., AIA, affiliated with Albert Kahn Associates in Detroit, has been appointed to the Michigan Board of Architects

The board sets qualifications and provides for the registration of architects to professional practice in the state

Enkemann is a vice president at Kahn, serves on the board of directors and is operations direc-



Alexander

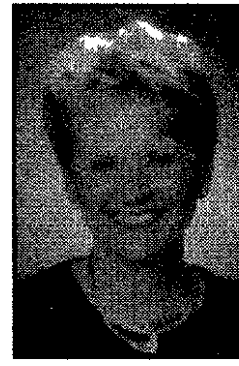

Walsh-Lapinski



Peters

tor for the automotive/ industrial group He joined the firm in 1978 Enkemann has a bachelor of

science degree in architecture from Lawrence Technological University and lives in Novi



NORTHVILLE
SPACIOUS COLONIAL IN MATURE SETTING! Original owner 4 br, 2.5 bath colonial Liv rm/Din rm w/warm hwdw flrs bay win Ceramic tiled foyer beautiful curved staircase den 1st flr lndry w/wet bar and storage for everything! Deck overlooks treed landscaped yard (PO5RAV) \$324 900

PLYMOUTH
PLYMOUTH - QUALITY THROUGHOUT Premium location for this superbly appointed condo 3 bdrm 3.5 baths 1st floor mstr ste natural maple and granite kitchen Fully finished walk out w/fmly rm gas flpc wet bar work out rm Two car gar This home will exceed your expectations! (P41BEA) \$445 000

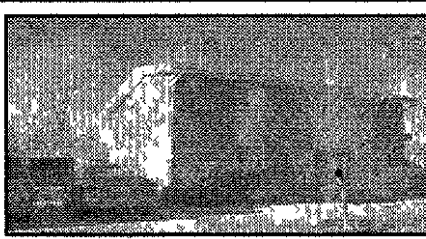

LIVONIA
SPRING VALLEY SUB Lovely updated 3 bdrm, 1.5 bath colonial in a great location Updates inc huge kit w/pull out drawers and ceramic flr win C/A newer HWH hwdw flrs and dishwasher Lg 21x12 den or computer rm Bsmt 1.5 car garage lg yard for kids (P16HAR) \$184 900

DEARBORN HEIGHTS
REMARKABLY MAINTAINED & UPDATED Brick ranch You will fall in love w/huge gourmet kit featuring 40 cabs bit in china cab bit in oven counter top range lighted pantry Fam rm boasts corner flpc w/gas logs New 8 ft doorwall & boasts corner flpc w/gas logs New windows c/a fur wtr tank shower in mstr (PO0WIL) \$299 900



CANTON
STUNNING RIVER WOODS COLONIAL! This better than new colonial has 4 br 2.5 baths boasts 2 story foyer 1st flr laundry hwdw entry open kit island/break bar and dr wall off nook to brick paver patio Sprinklers and Alarm! Private setting Corp Exclusion (P09RIV) \$339 900

LIVONIA
WONDERFUL HOME ON WOODED LOT Colonial 4 BR 3.5 baths Newer windows paint hwdw floors carpet & int doors Ceramic tiled entry hall kit & laundry room Mstr ste w/2 large walk in closets Bsmt has ceramic tile & full bath Huge leveled deck w/private woods (P62BRO) \$294 900

CREDIT COUNSELING TO BUY YOUR FIRST HOME

Sponsored by Approved Mortgages, Inc.

Credit Report for Attending

You may be able to buy your first home sooner than you thought possible, even if your credit isn't perfect.

- Is my credit okay?
- Credit Report Provided
- Can I qualify for a Mortgage?
- 100% Financing programs are now available

Saturday, April 27th
GreatLand Title
6044 N. Sheldon Rd., Canton
Reservation Time Slots: Please call
734-455-2219 ext. 242

HOMES SOLD IN WAYNE

These are the Observer & Eccentric-area residential real-estate closings recorded the week of Jan 7-11, 2001, at the Wayne County Register of Deeds office Listed below are cities, addresses and sales prices

Canton	
43106 Avon	\$190 000
1282 Asaz	\$45 000
411 Cherry Grv	\$227 000
431 Cherry Grv	\$262 000
470 Cherry Grv	\$270 000
490 Cherry Grv	\$231 000
491 Cherry Grv	\$264 000
501 Cherry Grv	\$230 000
521 Cherry Grv	\$258 000
128 Cherry Hill Pte	\$201 000
2405 Cleveland	\$328 000
2465 Cleveland	\$263 000
1625 Copeland	\$237 000
1809 Delancy	\$106 000
890 Glenuline	\$225 000
48581 Greenwich	\$96 000
48920 Greenwich	\$102 000
43180 Keystone	\$190 000
1628 Liberty N	\$100,000
570 Manhattan	\$125 000
39742 Peters	\$173 000
3883 Riverside	\$231,000
2606 Siever	\$307 000
543 Stonehenge	\$288,000

Garden City	
29644 Florence	\$145 000

Livonia	
16042 Alpine	\$175 000
11668 Arcola	\$75 000
29073 Barkley	\$172 000
9936 Bassett	\$188 000
20205 Deering	\$118,000
36540 Dowling	\$182,000
18506 Filmore	\$105 000
11004 Flamingo	\$151 000
15241 Houghton	\$189 000
11635 Inkster	\$93,000
15600 Loveland	\$240 000
19836 Maplewood	\$155 000
31154 Minton	\$162 000
28070 N Clements	\$127 000
37456 N Laurel Park	\$173 000
18995 Parklane	\$289 000
20125 Rensellor	\$125 000
34430 Richland	\$247 000
36572 Roycroft	\$196 000
17855 University Pk	\$132 000
16622 Woodside	\$312 000

Quality Properties Inc. Real Estate

1365 S. Main, Plymouth

(734) 451-5400

www.qualitybhg.com

WHERE CAN YOU FIND THESE FEATURES STARTING AT THE AFFORDABLE PRICE OF \$154,900??

Beat The May Price Increase!

- ✓ A 1,400 SQ. FT. TWO BEDROOM TOWNHOUSE, A 1,556 SQ. FT. THREE BEDROOM TOWNHOUSE OR A 1,350 SQ. FT. RANCH
- ✓ VAULTED CEILINGS
- ✓ FULL BASEMENTS
- ✓ TWO CAR ATTACHED GARAGES
- ✓ FIRST FLOOR LAUNDRY ROOM
- ✓ GARDEN PATHS THROUGH PARK AREAS ON A BEAUTIFUL WOODED AND LANDSCAPED SITE WITH DECORATIVE LIGHTED STREETS AND SIDEWALKS
- ✓ OPTIONS SUCH AS FIREPLACE, WOOD DECKS, SKYLIGHTS, NUMEROUS FLOORING AND CABINET CHOICES AND MUCH MORE
- ✓ MORTGAGE PAYMENT AS LOW AS **\$824/MONTH***

THE ANSWER: **FOREST PARK CONDOMINIUM**

VISIT OUR SALES OFFICE NOW THROUGH NOVEMBER 15, 2001 AND DRAW FOR A FREE UPGRADE OR OPTION VALID TOWARDS PURCHASE.

Visit our beautifully decorated models at **32994 Forest Avenue, Wayne, Michigan**

Call anytime at **734-722-3000**

Minutes away from Metro Airport, I-275 and I-94 X-Ways

Forest Park Condominium

*Payment based on a 30 year, 7% fixed interest loan rate with 20% down and includes principal and interest

Shay Estates of Livonia

OPEN HOUSE 12 - 5

Saturday and Sunday April 20th and 21st
Also April 27th and 28th

Everyone welcome! Come and see for yourself!

Victory Building Company, Inc
8 Beautiful Detached Ranch Condominiums
Only 6 Sites Left!

Located on Seven Mile Road just East of Newburgh Rd
On the south side

Pre-construction pricing from \$330,000
For more info please call Pam Harvey

248.615.9098

Quality Properties Inc. Real Estate

37699 Six Mile (Suite 200), Livonia

(734) 462-3000

Read the Eccentric every Thursday and Sunday

Plymouth	
12811 Hdden Crk	\$968 000
12028 Hunters Crk	\$1 224 000
42510 Lakeland	\$165 000
12115 Landers	\$870 000
1554 Lexington	\$181 000
1340 Lunden	\$100 000
40544 Newport	\$102 000
11287 Pnehurst	\$346 000
11264 Pnehurst	\$409 000
11293 Pnehurst	\$328,000
11400 Pnehurst	\$332,000
51282 Plymouth Lk	\$572,000
51364 Plymouth Lk	\$273 000
49852 Poente Xing	\$170,000
45815 Trilium W	\$417,000

Redford	
14255 Arnold	\$159 000
9637 Beech Daly	\$112 000
17690 Beech Daly	\$113 000
12821 Columbia	\$141 000
12842 Crosley	\$121 000
9336 Dixie	\$118 000
8842 Farley	\$119 000
17653 Fox	\$118 000
18812 Fox	\$120 000
25522 Lyndon	\$165 000
14201 Mercedes	\$147 000
12751 Nathalme	\$130 000
12040 Rockland	\$109 000
18473 Sumner	\$95 000

Westland	
7834 Moonwood	\$227 000
6275 N Dowling	\$139 000
34511 Pardo	\$40 000
637 Ravencrest	\$172 000
1355 Shoemaker	\$108 000
39820 Tawas Trl	\$161 000
34118 Tawas Trl	\$155 000



RealEstateOne.com

The Real Estate One Family of Companies

Johnstone & Johnstone • Max Broock Realtors • Ralph Manuel Associates

Trusted by more people
in more neighborhoods



Get the Best!



NORTHVILLE \$1,350,000
SURROUND YOURSELF IN ELEGANCE in prestigious Fox Hollow! Dramatic ceilings crown moldings gourmet kit w/granite magnificent mstr ceramic & hwdw flrs, fin d w o bsmt Numerous amenities!(35W002)
248-348-6430



NORTHVILLE \$649,900
SPECTACULAR WOODS OF EDENDERRY! Georgian Colonial features gourmet kitchen 5 BR, butlers pantry master suite w/balcony professionally fin d lower level!(63STO2)
248-348-6430



NORTHVILLE \$639,000
FABULOUS CUSTOM DESIGNED & BUILT HOME! 4 BR 3 1/2 baths open fir plan popular white woodwork granite hickory & lead glass kitchen Master bath w/bayed jacuzzi fin d daylight L/L (32PIN2)
248-348-6430



NORTHVILLE \$639,000
FABULOUS CUSTOM HOME IN FOX HOLLOW! 4 BR 3 1/2 baths main fir mstr ste hand carved mahogany, brazilian cherry hwdw fir in library 9 ceilings, granite countertops & much more!(05FOX2)
248-348-6430



PLYMOUTH \$537,500
READY & WAITING! Lovely turn key colonial! 4 bdrms, 4 baths 1 half bath Fabulous kit w/ white cbnts island pantry Fin bsmt w/kit bath Deck sprnklers, 3 car gar (23F10652)
PC 230192 734-455-7000



LIVONIA \$419,900
OVER 3200 SQ FT Lovely updated colonial in prvt ct setting Features 4 BR 3 1/2 bath spacious rms crown molding ceramic & hwdw Bsmnt has bath & 3 BR & xtra high ceiling (V35646)
PC 070172 734-591-9200



NORTHVILLE \$314,980
WONDERFUL 2-STORY 3 BR downtown Northville Condo! Open floor plan with GR dining room & library Finished daylight lower level!(10STL2)
248-348-6430



DEARBORN HEIGHTS \$299,000
ART DECO MODERN DREAM 3 bedroom 2 full and 1 1/2 bath tir-level offers walkins white kitchen w/built ins family room w/fireplace, heated all seasons room 2 car attached garage (C452)
PC 220172 734-326-2000



NORTHVILLE \$299,900
GREAT CURB APPEAL Beautiful cul de sac location on private setting well maintained FR w/vaulted ceiling deck 4 BR 2 1/2 baths possible 5th BR Over 2300 sq ft!(W42945)
734-591-9200



SOUTH LYON \$409,900
STUNNING COLONIAL IN TROTTERS POINTE! 3 3/2 SF 4 BR 3 1/2 baths incredible upgrades gourmet kitchen hwdw flrs natural FP w/gas line Nicely landscaped w/patio and great view!(04EQU2)
248-348-6430



HAMBURG \$368,000
CUSTOM BUILT COLONIAL on 2+plus acres! 4 BR 2 1/2 baths fin d walk out bsmt, many extras incl pole barn storage shed above ground pool & more!(15PIE2)
248-348-6430



NORTHVILLE \$314,980
WONDERFUL 2-STORY 3 BR downtown Northville Condo! Open floor plan with GR dining room & library Finished daylight lower level!(10STL2)
248-348-6430



DEARBORN HEIGHTS \$299,000
ART DECO MODERN DREAM 3 bedroom 2 full and 1 1/2 bath tir-level offers walkins white kitchen w/built ins family room w/fireplace, heated all seasons room 2 car attached garage (C452)
PC 220172 734-326-2000



NORTHVILLE \$299,900
GREAT CURB APPEAL Beautiful cul de sac location on private setting well maintained FR w/vaulted ceiling deck 4 BR 2 1/2 baths possible 5th BR Over 2300 sq ft!(W42945)
734-591-9200



NORTHVILLE \$299,900
DO YOU HAVE A HANDY ANDY IN YOUR FAMILY! Because if you do, this house is for you! Nestled on a private treed 3 8/2 ac lot Has 1 possible split and pole barn House has 726 sq ft in-law apartment (N8660)
734-591-9200



LIVONIA \$295,000
LOCATION, QUALITY, VALUE, & CHARM! Hidden Pines sub Brick colonial w/2 car att'd garage finished bsmt 3 BR 2 1/2 bath new rf & appliances mstr BR w/bath & walk in closet (C18912)
734-591-9200

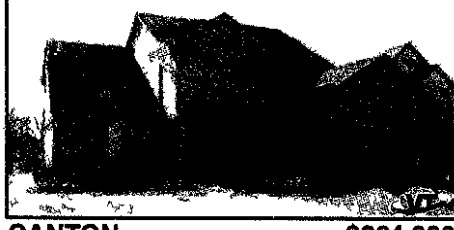

CANTON \$284,900
POPULAR CANTON NEIGHBORHOOD with Plymouth/Canton schools Offers 4 BR 2 1/2 baths finished bsmt 2 car att'd garage unique vaulted ceilings Family rm w/natural FP (D1353)
734-591-9200



CANTON \$237,900
DRAMATIC 2 STORY WITH PLATIUM WINDOW 1st floor master bay window in kitchen doorwall to deck loft w/skylights neutral decor 2 unit bldg maple flr in kitchen & powder rm (S351)
734-591-9200



CLARKSTON \$219,900
EXTRAORDINARY LOT! Beautifully landscaped 1st flr mstr w/skylight & jacuzzi 3 1/2 baths storage galore! 18 x 30 2 story garage Newer roof siding windows furnace & a/c (23P4420)
734-455-7000



CANTON \$219,900
NEAR SUMMIT & PARKS! Enjoy the sunrise in the 3 season Florida room 4 bdrm 2 full bath cape cod Maintenance free exterior full bsmt 2 car garage (23W1851)
PC P3617 734-455-7000



PLYMOUTH \$214,900
DOWNTOWN PLYMOUTH CHARMER! Remarkable curb appeal! Delightful inside, coved ceilings in LR original drs w/glass door knobs Updtd win siding gutters & bath Pergo flr in Retro kitchen (02ADA2)
248-348-6430

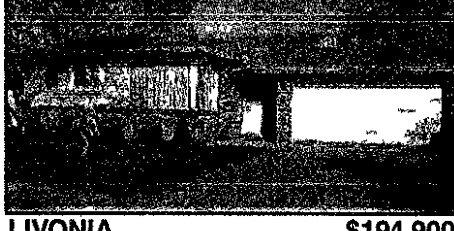

LIVONIA \$194,900
DESIRABLE 3 BR, 3 BATH BRICK RANCH in great sub! Newer kitchen with open FR swim club park and schools conveniently located in sub!(72STO2)
248-348-6430



CANTON \$189,900
UPDATED TO THE MAX! This 3 bdrm col is waiting for you! Updates include windows 91 roof tear off 00 Merilat kit, wood foyers & kit Wood deck off family room (23W41535)
734-455-7000



PLYMOUTH \$184,000
COMFORTABLE & NEUTRAL DECOR! Updated oak kitchen & baths 3 BR Ranch, c/a attached garage, fence fin d bsmt wonderful neighborhood & close to everything (71RUS2)
248-348-6430



WESTLAND \$175,000
JOIN THE MILLPOINTE FAMILY 3 bedrooms master with full bath family room w/fireplace doorwall to deck skylight oak kitchen, 2 full 1 half bath attached garage fenced yard (S234)
734-326-2000



DEARBORN \$174,900
MATCHLESS, METICULOUS, MEMORABLE Best describe this 4 BR Cape Cod 2 baths, Fin base C/A remodeled kit & baths formal dining rm 2 car garage and prof landscaped yard backyard arbor (G222)
734-326-2000

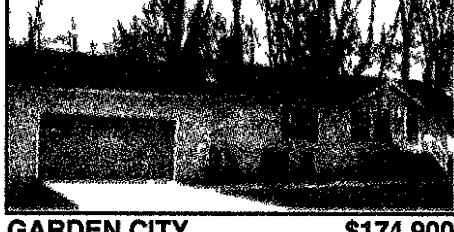

GARDEN CITY \$174,900
WHEN ONLY THE BEST WILL DO! This lovely traditional ranch sits on a large Country lot featuring 3 bedrooms 2 full baths dining room library breakfast nook and full basement (V153)
734-326-2000



FARMINGTON HILLS \$167,900
Totally remodeled new kitchen w/granite counters updated bath wndws, floor coverings maintenance free exterior huge country lot pack up & move in!(B34550)
PC 070662 734-591-9200



LIVONIA \$159,900
CHARMING 3/4 ACRE COLONIAL in a nice location - updated kitchen bath - 3 furnaces over 1500 sq ft 24x26 insulated garage - backs to elementary school with gate access (B19610)
734-591-9200



WESTLAND \$149,900
GREAT LOCATION, CLOSE TO EVERYTHING! 3 BR 1 1/2 bath colonial has been well cared for New 20x19 FR w/FP & hearth hrdwd in kit & dining area combo new wndws sprnk syst over 1700 sq ft!(J34815)
734-591-9200



LIVONIA \$149,900
PAINT BRUSH SPECIAL! Priced under market this 1700 sq ft ranch on a huge lot has an updated kitchen huge family rm 4 BR Do some cosmetics and watch your equity grow!(P19614)
PC 070592 734-591-9200

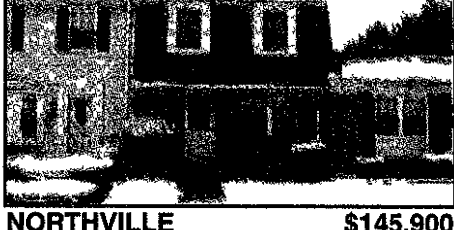

NORTHVILLE \$145,900
SHARP NORTHVILLE 2 BR CONDO w/ updated white kitchen & 1/2 bath Private entry fenced brick paver patio full bsmt 1 280 SF Enjoy pool lakes & clubhouse Quick occupancy! Hurry!(75IRO2)
248-348-6430



REDFORD \$141,000
EXCEPTIONAL REDFORD RANCH! Custom windows thruout professionally landscaped, 3 BR part finished basement, master BR has 11x4 WIC Must tour beautifully decorated home!(D26840)
PC 070662 734-591-9200



GARDEN CITY \$139,900
FABULOUS FEATURES Are to be found in this 3 bedroom aluminum Ranch with rec room, 2 car garage central air newer roof shingles, windows, remodeled kitchen and bath (R292)
PC 220282 734-326-2000



Garden City \$134,999
CHARMING BEST DESCRIBES 3 bedroom Bungalow major updates have been done Newer roof, new windows doors C/A, furnace Sun rm on back Landscape offers surprise spring time blooms (H581)
734-326-2000



WAYNE \$119,500
WONDERFUL BUNGALOW! A great buy for the 1st time buyer or the empty nester This 3 bdrm w/bsmt & 2 car gar is ready & waiting for you Newer windows, vinyl siding & new roof (23C34241)
734-455-7000

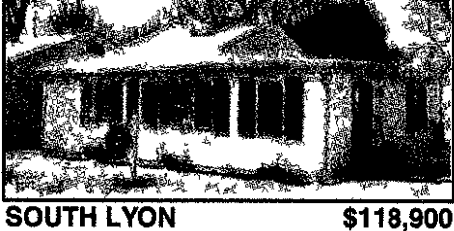

SOUTH LYON \$118,900
BRING YOUR BOAT & MOVE RIGHT IN! Lake access & dock facility on all sports Whitmore Lake Updated ranch w/open floor - living rm w/FP 2 car garage & fenced yard (B9157)
734-591-9200



ROMULUS \$114,900
JUST REDECORATED Brand new carpet plus remodeled kitchen in this 3 bedroom Tri Kitchen features Oak ceramic tile double sink w/veggie sink garden window Fireplace in LR (O156)
734-326-2000



GARDEN CITY \$114,900
BEST VALUE AROUND Is this vinyl-sided ranch Remodeled kit w/oak cabinets and bath Newer carpets tile & flooring shed, porch and awning C/A ceiling fans and insulation (E290)
734-326-2000



WESTLAND \$78,900
A REAL GEM This is a special 2BR condo w/ basement Completely updated w/mirrored wall in LR bath new windows furn & C/A neutral decor Plus you can't beat the price!(S183)
734-326-2000

FARMINGTON HILLS
CUSTOM BUILT 2-STORY HOME on cul-de-sac backing to woods! 4 BR 3 1/2 baths professionally fin d walk-out bsmt Open floor plan neutral decor updates!(33COU2)
\$414,900 248-348-6430

SOUTHFIELD
YOU CAN'T ASK FOR MUCH MORE THAN THIS! Beautiful brk ranch on almost 1/2 acre! Meticulously maintained w/ many updates Oak kit updated baths fin bsmt w/bath 3 car att'd heated garage & much more!(S20245)
\$269,900 PC 070272 734-591-9200

LIVONIA
BEAUTIFUL BELL CREEK SQUARE! New executive condo living at its best Brick & limestone exteriors bit 2001 2 BR 1 1/2 baths c/a FP, Whirlpool appliances builders warranty (F16854)
\$184,200 734-591-9200

NOVI
SUPER CONDO for 50+ that includes boat slip on all sports lake! Central air, 2 BR, 2 full baths, nice mstr BR w/private bath storage area & detached covered carport!(27LAK2)
\$144,900 734-591-9200

NOVI
SUPER CONDO for 50+ that includes boat slip on all sports lake! Central air, 2 BR, 2 full baths, nice mstr BR w/private bath storage area & detached covered carport!(27LAK2)
\$144,900 248-348-6430

Call Info Line at 888-REO-LIST, punch in the PC code #, get information!

This Classification Continued from Page 5E

314 Farmington/Farmington Hills

LOVELY RANCH Completely updated 2 bedroom Ranch style home on beautiful 74x162 lot Home features new kitchen & bath 1st floor laundry and 2 car detached garage w/3 car paved approach Call for details \$128,500 KAREN BROWN RE/MAX 100 (248) 348-3000

317 Garden City

FOR SALE BY OWNER GARDEN CITY

A MUST SEE! 3 bedroom 2 bath brick Ranch built in 1955 w/lots of extras 2.5 garage finished basement new roof & landscaping sprinkler system Asking \$149,900

LOCATED DEEP IN SUB ON A WOODED LOT Completely updated picture perfect colonial \$325,000 (FC 28)

LOVELY BRICK RANCH w/walk out basement on treed half acre 5 bedrooms 3 baths completely updated 3000 sq ft of spacious living space (22027598) RE/MAX 100 The Firestone Team 248 348 3000

SPACIOUS 3 bedroom 1200 sq ft ranch treed 4 acre lot updated throughout hardwood floors \$152,900 (248) 426-0349 (248) 669-2731

314 Farmington/Farmington Hills

LOVELY RANCH Completely updated 2 bedroom Ranch style home on beautiful 74x162 lot Home features new kitchen & bath 1st floor laundry and 2 car detached garage w/3 car paved approach Call for details \$128,500 KAREN BROWN RE/MAX 100 (248) 348-3000

317 Garden City

FOR SALE BY OWNER GARDEN CITY

A MUST SEE! 3 bedroom 2 bath brick Ranch built in 1955 w/lots of extras 2.5 garage finished basement new roof & landscaping sprinkler system Asking \$149,900

LOCATED DEEP IN SUB ON A WOODED LOT Completely updated picture perfect colonial \$325,000 (FC 28)

LOVELY BRICK RANCH w/walk out basement on treed half acre 5 bedrooms 3 baths completely updated 3000 sq ft of spacious living space (22027598) RE/MAX 100 The Firestone Team 248 348 3000

SPACIOUS 3 bedroom 1200 sq ft ranch treed 4 acre lot updated throughout hardwood floors \$152,900 (248) 426-0349 (248) 669-2731

314 Farmington/Farmington Hills

HOT! HOT! HOT! HOMES IN THE HILLS \$585,000 On cul de sac lot that backs to commons on golf course community Magnificent 3556 sq ft 4 bedroom 4 1/2 bath home has 2 story foyer & great room formal dining room family room w/fireplace 1st floor master suite fabulous kitchen finished basement 3 car garage (KE292)

On 1/2 acre lot 3 bedroom 2 1/2 bath colonial 2 story foyer great room w/fireplace dining room kitchen w/hardwood floors 1st floor laundry Fabulous master suite w/cathedral ceiling & whirlpool tub C/A Basement Patio deck 2 car garage in ground sprinkler system (TE304)

On 1/2 acre lot 3 bedroom 2 1/2 bath colonial 2 story foyer great room w/fireplace dining room kitchen w/hardwood floors 1st floor laundry Fabulous master suite w/cathedral ceiling & whirlpool tub C/A Basement Patio deck 2 car garage in ground sprinkler system (TE304)

On 1/2 acre lot 3 bedroom 2 1/2 bath colonial 2 story foyer great room w/fireplace dining room kitchen w/hardwood floors 1st floor laundry Fabulous master suite w/cathedral ceiling & whirlpool tub C/A Basement Patio deck 2 car garage in ground sprinkler system (TE304)

On 1/2 acre lot 3 bedroom 2 1/2 bath colonial 2 story foyer great room w/fireplace dining room kitchen w/hardwood floors 1st floor laundry Fabulous master suite w/cathedral ceiling & whirlpool tub C/A Basement Patio deck 2 car garage in ground sprinkler system (TE304)

On 1/2 acre lot 3 bedroom 2 1/2 bath colonial 2 story foyer great room w/fireplace dining room kitchen w/hardwood floors 1st floor laundry Fabulous master suite w/cathedral ceiling & whirlpool tub C/A Basement Patio deck 2 car garage in ground sprinkler system (TE304)

On 1/2 acre lot 3 bedroom 2 1/2 bath colonial 2 story foyer great room w/fireplace dining room kitchen w/hardwood floors 1st floor laundry Fabulous master suite w/cathedral ceiling & whirlpool tub C/A Basement Patio deck 2 car garage in ground sprinkler system (TE304)

On 1/2 acre lot 3 bedroom 2 1/2 bath colonial 2 story foyer great room w/fireplace dining room kitchen w/hardwood floors 1st floor laundry Fabulous master suite w/cathedral ceiling & whirlpool tub C/A Basement Patio deck 2 car garage in ground sprinkler system (TE304)

On 1/2 acre lot 3 bedroom 2 1/2 bath colonial 2 story foyer great room w/fireplace dining room kitchen w/hardwood floors 1st floor laundry Fabulous master suite w/cathedral ceiling & whirlpool tub C/A Basement Patio deck 2 car garage in ground sprinkler system (TE304)

On 1/2 acre lot 3 bedroom 2 1/2 bath colonial 2 story foyer great room w/fireplace dining room kitchen w/hardwood floors 1st floor laundry Fabulous master suite w/cathedral ceiling & whirlpool tub C/A Basement Patio deck 2 car garage in ground sprinkler system (TE304)

On 1/2 acre lot 3 bedroom 2 1/2 bath colonial 2 story foyer great room w/fireplace dining room kitchen w/hardwood floors 1st floor laundry Fabulous master suite w/cathedral ceiling & whirlpool tub C/A Basement Patio deck 2 car garage in ground sprinkler system (TE304)

On 1/2 acre lot 3 bedroom 2 1/2 bath colonial 2 story foyer great room w/fireplace dining room kitchen w/hardwood floors 1st floor laundry Fabulous master suite w/cathedral ceiling & whirlpool tub C/A Basement Patio deck 2 car garage in ground sprinkler system (TE304)

On 1/2 acre lot 3 bedroom 2 1/2 bath colonial 2 story foyer great room w/fireplace dining room kitchen w/hardwood floors 1st floor laundry Fabulous master suite w/cathedral ceiling & whirlpool tub C/A Basement Patio deck 2 car garage in ground sprinkler system (TE304)

On 1/2 acre lot 3 bedroom 2 1/2 bath colonial 2 story foyer great room w/fireplace dining room kitchen w/hardwood floors 1st floor laundry Fabulous master suite w/cathedral ceiling & whirlpool tub C/A Basement Patio deck 2 car garage in ground sprinkler system (TE304)

On 1/2 acre lot 3 bedroom 2 1/2 bath colonial 2 story foyer great room w/fireplace dining room kitchen w/hardwood floors 1st floor laundry Fabulous master suite w/cathedral ceiling & whirlpool tub C/A Basement Patio deck 2 car garage in ground sprinkler system (TE304)

On 1/2 acre lot 3 bedroom 2 1/2 bath colonial 2 story foyer great room w/fireplace dining room kitchen w/hardwood floors 1st floor laundry Fabulous master suite w/cathedral ceiling & whirlpool tub C/A Basement Patio deck 2 car garage in ground sprinkler system (TE304)

On 1/2 acre lot 3 bedroom 2 1/2 bath colonial 2 story foyer great room w/fireplace dining room kitchen w/hardwood floors 1st floor laundry Fabulous master suite w/cathedral ceiling & whirlpool tub C/A Basement Patio deck 2 car garage in ground sprinkler system (TE304)

On 1/2 acre lot 3 bedroom 2 1/2 bath colonial 2 story foyer great room w/fireplace dining room kitchen w/hardwood floors 1st floor laundry Fabulous master suite w/cathedral ceiling & whirlpool tub C/A Basement Patio deck 2 car garage in ground sprinkler system (TE304)

On 1/2 acre lot 3 bedroom 2 1/2 bath colonial 2 story foyer great room w/fireplace dining room kitchen w/hardwood floors 1st floor laundry Fabulous master suite w/cathedral ceiling & whirlpool tub C/A Basement Patio deck 2 car garage in ground sprinkler system (TE304)

On 1/2 acre lot 3 bedroom 2 1/2 bath colonial 2 story foyer great room w/fireplace dining room kitchen w/hardwood floors 1st floor laundry Fabulous master suite w/cathedral ceiling & whirlpool tub C/A Basement Patio deck 2 car garage in ground sprinkler system (TE304)

On 1/2 acre lot 3 bedroom 2 1/2 bath colonial 2 story foyer great room w/fireplace dining room kitchen w/hardwood floors 1st floor laundry Fabulous master suite w/cathedral ceiling & whirlpool tub C/A Basement Patio deck 2 car garage in ground sprinkler system (TE304)

On 1/2 acre lot 3 bedroom 2 1/2 bath colonial 2 story foyer great room w/fireplace dining room kitchen w/hardwood floors 1st floor laundry Fabulous master suite w/cathedral ceiling & whirlpool tub C/A Basement Patio deck 2 car garage in ground sprinkler system (TE304)

On 1/2 acre lot 3 bedroom 2 1/2 bath colonial 2 story foyer great room w/fireplace dining room kitchen w/hardwood floors 1st floor laundry Fabulous master suite w/cathedral ceiling & whirlpool tub C/A Basement Patio deck 2 car garage in ground sprinkler system (TE304)

On 1/2 acre lot 3 bedroom 2 1/2 bath colonial 2 story foyer great room w/fireplace dining room kitchen w/hardwood floors 1st floor laundry Fabulous master suite w/cathedral ceiling & whirlpool tub C/A Basement Patio deck 2 car garage in ground sprinkler system (TE304)

On 1/2 acre lot 3 bedroom 2 1/2 bath colonial 2 story foyer great room w/fireplace dining room kitchen w/hardwood floors 1st floor laundry Fabulous master suite w/cathedral ceiling & whirlpool tub C/A Basement Patio deck 2 car garage in ground sprinkler system (TE304)

On 1/2 acre lot 3 bedroom 2 1/2 bath colonial 2 story foyer great room w/fireplace dining room kitchen w/hardwood floors 1st floor laundry Fabulous master suite w/cathedral ceiling & whirlpool tub C/A Basement Patio deck 2 car garage in ground sprinkler system (TE304)

On 1/2 acre lot 3 bedroom 2 1/2 bath colonial 2 story foyer great room w/fireplace dining room kitchen w/hardwood floors 1st floor laundry Fabulous master suite w/cathedral ceiling & whirlpool tub C/A Basement Patio deck 2 car garage in ground sprinkler system (TE304)

On 1/2 acre lot 3 bedroom 2 1/2 bath colonial 2 story foyer great room w/fireplace dining room kitchen w/hardwood floors 1st floor laundry Fabulous master suite w/cathedral ceiling & whirlpool tub C/A Basement Patio deck 2 car garage in ground sprinkler system (TE304)

On 1/2 acre lot 3 bedroom 2 1/2 bath colonial 2 story foyer great room w/fireplace dining room kitchen w/hardwood floors 1st floor laundry Fabulous master suite w/cathedral ceiling & whirlpool tub C/A Basement Patio deck 2 car garage in ground sprinkler system (TE304)

On 1/2 acre lot 3 bedroom 2 1/2 bath colonial 2 story foyer great room w/fireplace dining room kitchen w/hardwood floors 1st floor laundry Fabulous master suite w/cathedral ceiling & whirlpool tub C/A Basement Patio deck 2 car garage in ground sprinkler system (TE304)

On 1/2 acre lot 3 bedroom 2 1/2 bath colonial 2 story foyer great room w/fireplace dining room kitchen w/hardwood floors 1st floor laundry Fabulous master suite w/cathedral ceiling & whirlpool tub C/A Basement Patio deck 2 car garage in ground sprinkler system (TE304)

On 1/2 acre lot 3 bedroom 2 1/2 bath colonial 2 story foyer great room w/fireplace dining room kitchen w/hardwood floors 1st floor laundry Fabulous master suite w/cathedral ceiling & whirlpool tub C/A Basement Patio deck 2 car garage in ground sprinkler system (TE304)

On 1/2 acre lot 3 bedroom 2 1/2 bath colonial 2 story foyer great room w/fireplace dining room kitchen w/hardwood floors 1st floor laundry Fabulous master suite w/cathedral ceiling & whirlpool tub C/A Basement Patio deck 2 car garage in ground sprinkler system (TE304)

On 1/2 acre lot 3 bedroom 2 1/2 bath colonial 2 story foyer great room w/fireplace dining room kitchen w/hardwood floors 1st floor laundry Fabulous master suite w/cathedral ceiling & whirlpool tub C/A Basement Patio deck 2 car garage in ground sprinkler system (TE304)

On 1/2 acre lot 3 bedroom 2 1/2 bath colonial 2 story foyer great room w/fireplace dining room kitchen w/hardwood floors 1st floor laundry Fabulous master suite w/cathedral ceiling & whirlpool tub C/A Basement Patio deck 2 car garage in ground sprinkler system (TE304)

On 1/2 acre lot 3 bedroom 2 1/2 bath colonial 2 story foyer great room w/fireplace dining room kitchen w/hardwood floors 1st floor laundry Fabulous master suite w/cathedral ceiling & whirlpool tub C/A Basement Patio deck 2 car garage in ground sprinkler system (TE304)

On 1/2 acre lot 3 bedroom 2 1/2 bath colonial 2 story foyer great room w/fireplace dining room kitchen w/hardwood floors 1st floor laundry Fabulous master suite w/cathedral ceiling & whirlpool tub C/A Basement Patio deck 2 car garage in ground sprinkler system (TE304)

On 1/2 acre lot 3 bedroom 2 1/2 bath colonial 2 story foyer great room w/fireplace dining room kitchen w/hardwood floors 1st floor laundry Fabulous master suite w/cathedral ceiling & whirlpool tub C/A Basement Patio deck 2 car garage in ground sprinkler system (TE304)

On 1/2 acre lot 3 bedroom 2 1/2 bath colonial 2 story foyer great room w/fireplace dining room kitchen w/hardwood floors 1st floor laundry Fabulous master suite w/cathedral ceiling & whirlpool tub C/A Basement Patio deck 2 car garage in ground sprinkler system (TE304)

On 1/2 acre lot 3 bedroom 2 1/2 bath colonial 2 story foyer great room w/fireplace dining room kitchen w/hardwood floors 1st floor laundry Fabulous master suite w/cathedral ceiling & whirlpool tub C/A Basement Patio deck 2 car garage in ground sprinkler system (TE304)

On 1/2 acre lot 3 bedroom 2 1/2 bath colonial 2 story foyer great room w/fireplace dining room kitchen w/hardwood floors 1st floor laundry Fabulous master suite w/cathedral ceiling & whirlpool tub C/A Basement Patio deck 2 car garage in ground sprinkler system (TE304)

On 1/2 acre lot 3 bedroom 2 1/2 bath colonial 2 story foyer great room w/fireplace dining room kitchen w/hardwood floors 1st floor laundry Fabulous master suite w/cathedral ceiling & whirlpool tub C/A Basement Patio deck 2 car garage in ground sprinkler system (TE304)

On 1/2 acre lot 3 bedroom 2 1/2 bath colonial 2 story foyer great room w/fireplace dining room kitchen w/hardwood floors 1st floor laundry Fabulous master suite w/cathedral ceiling & whirlpool tub C/A Basement Patio deck 2 car garage in ground sprinkler system (TE304)

On 1/2 acre lot 3 bedroom 2 1/2 bath colonial 2 story foyer great room w/fireplace dining room kitchen w/hardwood floors 1st floor laundry Fabulous master suite w/cathedral ceiling & whirlpool tub C/A Basement Patio deck 2 car garage in ground sprinkler system (TE304)

325 Livonia

BRICK RANCH 3 bedroom 2 bath finished basement large yard \$154,900 (734) 425 0869

BY OWNER 6 Mile Inkster area brick ranch \$169,900 Appt 734-525 9631

Call your Livonia Specialist CHARLOTTE JACUNSKI (734) 377 3282

DEERCREEK 4 bedroom 2 1/2 bath colonial has it all! Formal living & dining rooms huge family room w/fireplace library year round Florida room Finished basement 1st floor laundry 3 car garage much more!

ALL UPDATES ARE DONE! 3 bedroom 2 baths & a 29 x 13 master bedroom New addition family room w/fireplace Finished basement with spa style bath 2 1/2 garage 1750 sq ft Century 21 Row 734-464-7111

GORGEOUS 4 bedroom 2 bath ranch on large lot Open floor plan new kitchen family room finished basement C/A 2 car garage updated throughout \$234,900 734 266 0707

LIVONIA \$276,500 Attractive 4 bedroom 2 1/2 bath Colonial on cul de sac features 15x11 Florida room 1st floor laundry & updated kitchen Other updates include furnace central air w/ceramic floor & bay window roof gutters & driveway 20x10 sun room Attached garage Stevenson High School (19SS)

DARLING 3 bedroom ranch on large corner lot Master bedroom w/natural fireplace & walk in closet Family room doorwalk leads to patio & in ground pool Newer roof Home warranty (308R)

LIVONIA FOR UNDER \$160K LARGE PRIVATE lot for this mint country chamer 2 Bed room 1 bath ranch w/updates throughout including kitchen w/ceramic floor & bay window roof gutters & driveway 20x10 sun room Attached garage Stevenson High School (19SS)

PLYMOUTH TWP Great location 3 bedroom Cape Cod 2 1/2 bath 2 car attached garage built 1995 asking \$304,900 Bring offers 734-416 1046

PLYMOUTH TWP Ridgewood Hills 4 bedroom 2 1/2 bath finished basement in ground pool cedar shake roof \$419,000 48727 Robin Ct. 734-459 1668

PLYMOUTH UPDATED ranch \$139,900 All appliances & warranty Ask for Jeff G 734-453-0012 ext 228 (JGCO-P)

SEARCH 1000's of Realtor property listings at www.HomeTownLife.com Part of the Observer and Eccentric classified network

RE/MAX HANNETT-WILSON & WHITEHOUSE (248) 646-6200

SEARCH 1000's of Realtor property listings at www.HomeTownLife.com Part of the Observer and Eccentric classified network

RE/MAX HANNETT-WILSON & WHITEHOUSE (248) 646-6200

SEARCH 1000's of Realtor property listings at www.HomeTownLife.com Part of the Observer and Eccentric classified network

RE/MAX HANNETT-WILSON & WHITEHOUSE (248) 646-6200

SEARCH 1000's of Realtor property listings at www.HomeTownLife.com Part of the Observer and Eccentric classified network

RE/MAX HANNETT-WILSON & WHITEHOUSE (248) 646-6200

SEARCH 1000's of Realtor property listings at www.HomeTownLife.com Part of the Observer and Eccentric classified network

RE/MAX HANNETT-WILSON & WHITEHOUSE (248) 646-6200

SEARCH 1000's of Realtor property listings at www.HomeTownLife.com Part of the Observer and Eccentric classified network

RE/MAX HANNETT-WILSON & WHITEHOUSE (248) 646-6200

SEARCH 1000's of Realtor property listings at www.HomeTownLife.com Part of the Observer and Eccentric classified network

RE/MAX HANNETT-WILSON & WHITEHOUSE (248) 646-6200

SEARCH 1000's of Realtor property listings at www.HomeTownLife.com Part of the Observer and Eccentric classified network

RE/MAX HANNETT-WILSON & WHITEHOUSE (248) 646-6200

SEARCH 1000's of Realtor property listings at www.HomeTownLife.com Part of the Observer and Eccentric classified network

RE/MAX HANNETT-WILSON & WHITEHOUSE (248) 646-6200

SEARCH 1000's of Realtor property listings at www.HomeTownLife.com Part of the Observer and Eccentric classified network

RE/MAX HANNETT-WILSON & WHITEHOUSE (248) 646-6200

SEARCH 1000's of Realtor property listings at www.HomeTownLife.com Part of the Observer and Eccentric classified network

RE/MAX HANNETT-WILSON & WHITEHOUSE (248) 646-6200

SEARCH 1000's of Realtor property listings at www.HomeTownLife.com Part of the Observer and Eccentric classified network

RE/MAX HANNETT-WILSON & WHITEHOUSE (248) 646-6200

SEARCH 1000's of Realtor property listings at www.HomeTownLife.com Part of the Observer and Eccentric classified network

RE/MAX HANNETT-WILSON & WHITEHOUSE (248) 646-6200

SEARCH 1000's of Realtor property listings at www.HomeTownLife.com Part of the Observer and Eccentric classified network

RE/MAX HANNETT-WILSON & WHITEHOUSE (248) 646-6200

SEARCH 1000's of Realtor property listings at www.HomeTownLife.com Part of the Observer and Eccentric classified network

RE/MAX HANNETT-WILSON & WHITEHOUSE (248) 646-6200

SEARCH 1000's of Realtor property listings at www.HomeTownLife.com Part of the Observer and Eccentric classified network

RE/MAX HANNETT-WILSON & WHITEHOUSE (248) 646-6200

334 Plymouth

HALF ACRE brick ranch attached 2 car garage updated C/A 3 bedrooms 2 1/2 baths hardwood fireplace screened porch finished basement \$225,000 734-667-3047

845 HARTSOUGH \$247,500 3 bedrooms (incredible master suite addition) 2 full baths and a plethora of updates including siding roof windows and plumbing Don't let the small house look from the front deceive you Be a Towny! Fred Hill 734 416 1257 Coldwell Banker Preferred

LOVELY 5 BEDROOM historical home on 1 1/2 acres across Spacious rooms plus 2 enclosed decks Basement garage for only \$289,900 (22013432) RE/MAX 100 The Firestone Team 248 348 3000

PLYMOUTH CAPE COD In town 3 bedroom 3 bath shingled home w/white tile occupying 1/2 acre lot includes updated kitchen & bath City award for landscaping in 2001! Full basement w/9 ceilings WOW! \$235,000 DENISE MCGUIGAN (313) 796 1436

PLYMOUTH Open Sun 1-4 Walk to downtown A must see beautiful custom built 1992 by owner 2345 sqft 4 bedroom 3 1/2 baths spacious oak kitchen Corian countertops thru out Andersen windows w/office 5th bedroom master bath w/whirlpool & walk in closet 2 car attached garage C/A deck in ground sprinklers \$335,000 9250 Ball 734-604 7435

PLYMOUTH TWP Great location 3 bedroom Cape Cod 2 1/2 bath 2 car attached garage built 1995 asking \$304,900 Bring offers 734-416 1046

PLYMOUTH TWP Ridgewood Hills 4 bedroom 2 1/2 bath finished basement in ground pool cedar shake roof \$419,000 48727 Robin Ct. 734-459 1668

PLYMOUTH UPDATED ranch \$139,900 All appliances & warranty Ask for Jeff G 734-453-0012 ext 228 (JGCO-P)

SEARCH 1000's of Realtor property listings at www.HomeTownLife.com Part of the Observer and Eccentric classified network

RE/MAX HANNETT-WILSON & WHITEHOUSE (248) 646-6200

SEARCH 1000's of Realtor property listings at www.HomeTownLife.com Part of the Observer and Eccentric classified network

RE/MAX HANNETT-WILSON & WHITEHOUSE (248) 646-6200

SEARCH 1000's of Realtor property listings at www.HomeTownLife.com Part of the Observer and Eccentric classified network

RE/MAX HANNETT-WILSON & WHITEHOUSE (248) 646-6200

SEARCH 1000's of Realtor property listings at www.HomeTownLife.com Part of the Observer and Eccentric classified network

RE/MAX HANNETT-WILSON & WHITEHOUSE (248) 646-6200

SEARCH 1000's of Realtor property listings at www.HomeTownLife.com Part of the Observer and Eccentric classified network

RE/MAX HANNETT-WILSON & WHITEHOUSE (248) 646-6200

SEARCH 1000's of Realtor property listings at www.HomeTownLife.com Part of the Observer and Eccentric classified network

RE/MAX HANNETT-WILSON & WHITEHOUSE (248) 646-6200

SEARCH 1000's of Realtor property listings at www.HomeTownLife.com Part of the Observer and Eccentric classified network

RE/MAX HANNETT-WILSON & WHITEHOUSE (248) 646-6200

SEARCH 1000's of Realtor property listings at www.HomeTownLife.com Part of the Observer and Eccentric classified network

RE/MAX HANNETT-WILSON & WHITEHOUSE (248) 646-6200

SEARCH 1000's of Realtor property listings at www.HomeTownLife.com Part of the Observer and Eccentric classified network

RE/MAX HANNETT-WILSON & WHITEHOUSE (248) 646-6200

SEARCH 1000's of Realtor property listings at www.HomeTownLife.com Part of the Observer and Eccentric classified network

RE/MAX HANNETT-WILSON & WHITEHOUSE (248) 646-6200

SEARCH 1000's of Realtor property listings at www.HomeTownLife.com Part of the Observer and Eccentric classified network

RE/MAX HANNETT-WILSON & WHITEHOUSE (248) 646-6200

SEARCH 1000's of Realtor property listings at www.HomeTownLife.com Part of the Observer and Eccentric classified network

RE/MAX HANNETT-WILSON & WHITEHOUSE (248) 646-6200

SEARCH 1000's of Realtor property listings at www.HomeTownLife.com Part of the Observer and Eccentric classified network

RE/MAX HANNETT-WILSON & WHITEHOUSE (248) 646-6200

SEARCH 1000's of Realtor property listings at www.HomeTownLife.com Part of the Observer and Eccentric classified network

RE/MAX HANNETT-WILSON & WHITEHOUSE (248) 646-6200

SEARCH 1000's of Realtor property listings at www.HomeTownLife.com Part of the Observer and Eccentric classified network

RE/MAX HANNETT-WILSON & WHITEHOUSE (248) 646-6200

SEARCH 1000's of Realtor property listings at www.HomeTownLife.com Part of the Observer and Eccentric classified network

RE/MAX HANNETT-WILSON & WHITEHOUSE (248) 646-6200

SEARCH 1000's of Realtor property listings at www.HomeTownLife.com Part of the Observer and Eccentric classified network

RE/MAX HANNETT-WILSON & WHITEHOUSE (248) 646-6200

SEARCH 1000's of Realtor property listings at www.HomeTownLife.com Part of the Observer and Eccentric classified network

RE/MAX HANNETT-WILSON & WHITEHOUSE (248) 646-6200

335 Redford

PICTURESQUE! Fabulous 3 bedroom Ranch C/A New driveway & finished basement updated electrical Bay window in kitchen Deck off of bed room Porch Sprinklers Attached 2 car garage \$104,900 (VA268)

<

372 Condos Farmington ATTRACTIVE 2 BEDROOM CONDO for \$95,000! Updated kitchen and bath wood floors newer furnace A/C plus lots of storage in basement (22014684) Re/Max 100 (248) 348-3000 The Firestone Team

FARMINGTON HILLS Rambles wood Sub Beautiful 1995 detached ranch condo w/walk out 2300 sq ft library soaring ceilings fireplace skylights granite counters Jacuzzi hot tub wood floors \$389,500 Owner/Agent 248 788 1481

FARMINGTON HILLS Oak Crest condo 1st floor 2 bedroom 2 bath 2 car garage fire place \$167,900 (248) 848 0218

FARMINGTON HILLS Great location! End unit ranch condo 2 bedroom 2 bath. Additional bedroom and half bath in finished lower level Brnc paver patio skylight Living room with fire place Immediate occupancy \$170,000 (248) 851 8700 CENTURY 21 M/L CORP TRANS SERVICE

Farmington Hills RANCH END UNIT IN PRIVATE COMPLEX Foyer opens to large living room w/gas fireplace dining room white & bright kitchen w/white eating space All appliances stay Master bedroom has 2 walk in closets set tub/separate shower Full basement large deck \$279,900 (WY 25) Real Estate One (248) 851-4100

FARMINGTON HILLS Senior Community 2 bedroom 2 bath new carpet throughout Shown by appt (734) 542 9485* (248) 477-3226

FARMINGTON HILLS \$176,500 Move in condition! Super sharp 2 bedroom 2 full bath ranch condo on wooded site Spacious living room w/marble gas fireplace dining room & 1st floor laundry 2 car attached garage w/pull down stairs to 400 sq ft of storage (LA294) Century 21 CENTURY 21 TODAY (248) 647 7321

NEW CONSTRUCTION Livonia Brownstone condo Beautiful 1200 sq ft includes 2 bedrooms 1 1/2 baths open floor plan gas fireplace A/C Whirl pool appliances basement and single car garage \$188,950 Bell Creek Square Jennifer Wenzel 734-367 7547

LIVONIA 3 YEARS NEW! 2100 sq ft 3 bedroom 2 1/2 bath cape cod Full basement 2 car garage Many upgrades All appliances included For pictures and details visit www.foresalebyowner.com Listing ID# 10070253 Asking \$299,900 Call 248 476 4234

NORTHVILLE 2 bedroom 2 bath ground level N Ridge Estates Very clean Asking \$131,500 MeadowManagement Inc 248 348 5400

Northville OPEN SUN 1-4pm 2 bedroom 1 bath condo in Highland Lakes Updated kitchen bath & windows Full basement 19503 Darmouth Place N7 Mile W/oft Silver Springs \$141,900 DENISE BUSSER 248 870 2183 Real Estate One 43155 Man Ste 2300 Nov

NOVI IMMEDIATE OCCUPANCY Ten Mile/Haggerty area One story condo End unit 2 bedroom 1 1/2 baths finished basement Newer windows roof and furnace Assigned parking Includes use of pool clubhouse and tennis courts Sellers motivated! \$134,900 CALL ROSE KOVAL

RIVERPOINTE (734) 671 3020 (313) 325 5127

NOVI LIGHT BRIGHT AIRY 2 bedroom 2 bath condo with basement and garage for only \$154,900 Vaulted ceilings plus carpet kitchen floor etc Large porch and located in Country Place \$129,000 248-374-1279

NOVI RANCH 3 bedroom 2 bath professionally finished basement Pool park & lake privileges Exec Novi schools \$153,900 (248) 305 9788

NOVI RANCH CONDO 2 bed room 1 bath 1 car garage 880 sq ft updates C/A furnace carpet kitchen floor etc Large porch and located in Country Place \$129,000 248-374-1279

NOVI 2,200 Sq ft 2 Bedrooms 2 baths. Chef's kitchen w/granite countertops and breakfast nook Formal living and dining room Separate den plus a year round sun-room filled with natural light Spectacular wooded and water views Traditional Finishes from \$235,000 Luxury Finishes from \$305,000 Contact Bob Bowden with The Firestone Team 248-348-8866

PLYMOUTH Anxious owner has reduced listed price of \$1148 North View in Country Club Village to \$344,900 2001 built library 3 bedrooms 2 1/2 baths loft overlook premium trim package Go for it! Fred Hill 734-416 1257 Coldwell Banker Preferred

PLYMOUTH Bradbury Great Ranch Condo in 55+ community 2 bedrooms large walk in closets 1 1/2 baths upper laundry good size rooms, large open basement all appliances \$130,600 734-981 3093

ROCHESTER HILLS Fabulous View Overlooking Great Oaks Country Club Golf Course End Unit 3 bedroom 2 full & 2 Half Baths finished walkout lower level appliances included \$265,000 248 693 0813

372 Condos ROYAL OAK North Luxury condos 4622 & 4624 Rochester Rd 3 bedrooms 2 1/2 baths fire place basement garage From \$234,800 248 588 6426 248-589 0453

GATEWAY PARK W Bloomfield Condo backs up to nature preserve 2 bedroom library full basement 2 car garage walk to shopping res taurants \$350,905 June Howell 248 538 0200

GATEWAY PARK Walk to shopping from this beautiful W Bloomfield Condo 1st floor master 3 bedrooms gourmet kitchen w/landed 2 car garage full basement 2 1/2 baths \$328,880 June Howell 248 538-0200

Walled Lake LAKESIDE CONDO Lovely 2 bedroom 2 bath freshly painted condo with huge deck w/lakeview! All appliances included Laundry room in unit Boat dockage possible! Garage Only \$142,500 RE/MAX 100 The Firestone Team 248 348 3000

Wayne IMMEDIATE OCCUPANCY NEW CONSTRUCTION 2 bedroom 2 1/2 bath Townhouse w/loft or bedroom & 2 bedroom 2 bath ranch Special Price starting at \$162,750 Many options included \$2994 Forest Ave 1 bks S of Michigan W off Venoy 734 722 3000

W BLOOMFIELD Open Sun April 28 Noon 5pm 2 bedroom 2 1/2 bath detached ranch condo built 1989 Super clean incredible stone fireplace & finished basement Maple Place Villas (15 Miles & Huron) \$279,900 Call first (248) 821 2390

W BLOOMFIELD Spacious 1st floor condo 2 bedrooms 2 baths neutral decor attached garage full basement private porch \$169,500 248-851 6389

WESTLAND 1274 sq ft 2 bedroom 2 bath all appliances Walk in closet cathedral ceiling garage end unit \$132,500 (734) 729 3958

373 Duplexes & Townhouses RIVER PARK VILLAGE Small town charm Beautiful 2 bedroom 2 1/2 bath townhome located in the city of Northville Features AC and fireplace 1620 sq ft of easy living 4 units available from the \$230's Michael McDonald 248 449 6844

374 Manufactured Homes BANK REPOS \$500 down to qualified buyers Good credit needed credit OK 2 yr site rent incentive Interest Sunrise Homes 248 866 1993

377 Lakefront Property BRIGHTON Best lot on Woodland Lake Bluffs sub \$199,900 includes boat lift (810) 231 8112

IN NOVI Spring Special SKYLINE Over 1000 sq ft 2 bed 2 baths C/A premium site Reduced to \$37,900

VICTORIAN Over 1300 sq ft all appliances C/A Whirlpool tub skylights premium site & more Must be seen \$39,900

BENDIX 2 bed 2 baths most all appliances well maintained \$10,900

SKYLINE over 1200 sq ft 3 bed 2 baths all appliances C/A premium site \$33,500

NOVI Schools at HIGHLAND HILLS ESTATES on Sealey Rd N of Grand River bet Meadowbrook & Haggerty Rds Call Joanne or Sue (248) 474-0320 or (248) 474-0333

IN WHITE LAKE OWN A NEW HOME FOR \$338/MONTH PLUS \$2000 CASH BACK* New Homes Priced From the \$20's

3 bedrooms 2 baths GE appliances Skylights

NOVI RANCH 3 bedroom 2 bath professionally finished basement Pool park & lake privileges Exec Novi schools \$153,900 (248) 305 9788

NOVI RANCH CONDO 2 bed room 1 bath 1 car garage 880 sq ft updates C/A furnace carpet kitchen floor etc Large porch and located in Country Place \$129,000 248-374-1279

NOVI 2,200 Sq ft 2 Bedrooms 2 baths. Chef's kitchen w/granite countertops and breakfast nook Formal living and dining room Separate den plus a year round sun-room filled with natural light Spectacular wooded and water views Traditional Finishes from \$235,000 Luxury Finishes from \$305,000 Contact Bob Bowden with The Firestone Team 248-348-8866

PLYMOUTH Anxious owner has reduced listed price of \$1148 North View in Country Club Village to \$344,900 2001 built library 3 bedrooms 2 1/2 baths loft overlook premium trim package Go for it! Fred Hill 734-416 1257 Coldwell Banker Preferred

PLYMOUTH Bradbury Great Ranch Condo in 55+ community 2 bedrooms large walk in closets 1 1/2 baths upper laundry good size rooms, large open basement all appliances \$130,600 734-981 3093

ROCHESTER HILLS Fabulous View Overlooking Great Oaks Country Club Golf Course End Unit 3 bedroom 2 full & 2 Half Baths finished walkout lower level appliances included \$265,000 248 693 0813

374 Manufactured Homes WHO WANTS TO BE A HOME OWNER? 7.99% APR! Country Living City Convenience For Just \$1000 Down Live in Farmington Novi Northville Canton South Lyon or Southfield community for under \$650/month including site rent! Thru April 30 Call Today 734-461 1389 *based on 7.99% APR Must qualify Limited time offer

Little Valley Wooded with end of the road privacy sand frontage and a gentle slope to a great fishing lake! \$66,900 8 8 Daily Loon Lake Realty TOLL FREE 888 805 5320 www.loonlake.com

375 Mobile Homes BY OWNER Westland Meadows 1995 14x80 Patriot fireplace C/A enclosed 10x24 ft deck Reduced to \$29,900 734 516 6591

CANTON/BELLEVIEW \$9900 1980 14x70 2 bedroom large living room appliances Mobile Home Brokers (734)697 2433

CANTON HOLIDAY ESTATES 1986 14x70 3 bedroom Appliances \$12,000/best NICE Home! (734) 355 6200

CANTON 1987 14x70 3 bed room 2 bath appliances shed air awning \$12,000/neg Mobile Home Brokers (734)697 2433

377 Lakefront Property BLOOMFIELD 124 on Orchard Lake Great views! \$990,000 Call Doug Keating at Snyder Kinney Bennett & Keating (248) 644-7000

IRISH HILLS Private Lake Columbia 98 frontage w/boat lift \$96,500/best (248) 465 6965

LAKE MI FRONTAGE 150 ft Meander Line Rd in Charlevoix Lot is wooded with ravine Asking \$769,000 248 542 0281

SECLUDED LAKEFRONT! Wooded with end of the road privacy sand frontage and a gentle slope to a great fishing lake! \$66,900 8 8 Daily Loon Lake Realty TOLL FREE 888 805 5320 www.loonlake.com

379 Northern Property GAYLORD 4.85 Beautifully Wooded Acres Short drive to State Land Jordan River and snowmobile trails Ideal camping and hunting base Driveway cleared site electric \$26,900 \$500 down \$330/mo 11% Land Contract www.northernlandco.com for survey and photos Northern Land Company 1 800 968 3118

HARBOR SPRINGS Magnificent spacious 4 bed room 4 bath home on large Lake Michigan lot Minutes from downtown \$1,430,000 Call Bob at (231) 526 6251 GRAHAM REAL ESTATE

PLYMOUTH HILLS Mobile Home Park Must Sacrifice!!! 2000 Dutch 16x70 3 bedroom 2 full baths C/A many extras \$30,000/best offer 248 738-5594 248-425 3062

PLYMOUTH 1992 Fleetwood 3 bedroom 2 bath all amenities 1/2 acre lot in Park Plymouth Hills \$31,000 Must see! Call (734) 455 3414

WESTLAND MEADOWS LLC Mobile home community 734-729 5500 New homes & sites available RENT STARTS UNDER \$300 for new home with participating dealers Call for details

WESTLAND MEADOWS NEW MODELS & SITES AVAILABLE SPECIAL current models only RENT FOR \$200 OR LESS Call for details 744 729-5500

WESTLAND Over 50 listings Pre owned & new homes Prices starting as low as \$14K for 14x70 2 bedroom central air Century Sales (734) 595 7535

382 Lots & Acreage/Vacant 1/2 ACRE of quiet neighbor Woodland Lake Bluffs sub \$199,900 Days 586 322 7184 After 7 586 247 1076

BRIGHTON 13 acres plus boat slip woodshed Appraised \$115,000 \$99,500/best offer (810) 227 3924

DESIRABLE SUB in New Hudson 1+ acre Ready to build \$90,000 (248) 437 0557

382 Lots & Acreage/Vacant ANNOUNCING TIMBERVIEW ACRES Low Down Payment Gentle rolling 2 1/2 acre sites some w/walkout basement your builder Easy access to western suburbs and Ann Arbor Financing Terms Available J A Bloch & Co/Gary Realty (248) 559 7430

BLOOMFIELD HILLS Lots available 4 acre to almost 4 acres We have both walk out and wooded lots Priced from \$395,000 Call Doug Keating at Snyder Kinney Bennett & Keating 248 644 7000 cell 248 330 9761

BRIGHTON 4.7 acres 1.8 acres wooded & rolling lake privileges \$149,900 \$115,000 (810) 227 3924

BRIGHTON 13 acres plus boat slip woodshed Appraised \$115,000 \$99,500/best offer (810) 227 3924

IN CANTON OWN A NEW HOME FOR \$360/MONTH PLUS \$2000 CASH BACK* New Homes Priced From the \$20's

3 bedrooms 2 baths GE appliances Skylights & More

NOVI Schools at Sherwood Village on southeast corner of Michigan Ave & Haggerty Rd Call Bernie (734) 397-7774

IN WIXOM OWN A NEW HOME FOR \$321/MONTH PLUS \$2000 CASH BACK* New Homes Priced From the \$20's

3 bedrooms 2 baths GE appliances Skylights

NOVI Schools at KENSINGTON PLACE On Grand River 1.96 to exit 153 Across from Kensington Metropark Call Erin (248) 437-2039

IN WIXOM OWN A NEW HOME FOR \$347/MONTH PLUS \$2000 CASH BACK* New Homes Priced From the \$20's

3 bedrooms 2 baths GE appliances Skylights

NOVI Schools at COMMERC MEADOWS on Wixom Rd 4 miles N of I-96 Call Kathy Snook (248) 684-6796

382 Lots & Acreage/Vacant ANNOUNCING TIMBERVIEW ACRES Low Down Payment Gentle rolling 2 1/2 acre sites some w/walkout basement your builder Easy access to western suburbs and Ann Arbor Financing Terms Available J A Bloch & Co/Gary Realty (248) 559 7430

BLOOMFIELD HILLS Lots available 4 acre to almost 4 acres We have both walk out and wooded lots Priced from \$395,000 Call Doug Keating at Snyder Kinney Bennett & Keating 248 644 7000 cell 248 330 9761

BRIGHTON 4.7 acres 1.8 acres wooded & rolling lake privileges \$149,900 \$115,000 (810) 227 3924

BRIGHTON 13 acres plus boat slip woodshed Appraised \$115,000 \$99,500/best offer (810) 227 3924

382 Lots & Acreage/Vacant BUILD YOUR OWN HOME Save \$1,000's 0% Construction Loan 1.5% down payment to start Pierson Gibbs Homes build the shell you finish it Any plan/size (800) 799 7417

HIGHLAND TWP 5 acres on Hickory Ridge near GM Proving Grounds Perked & surveyed \$147,000 (248) 505 8966

SALEM 3 lots available from \$70,000 \$150,000 South Lyon Schools Call Arnold Associates Inc (248)626 7557 Gary

SALEM TWP Approximately 2 acres in Salem Farms Estates Sub Cul de sac \$150,000 (248) 459 3391

SEARCH 1000's of Real Estate property listings at www.HomeTownLife.com Part of the Observer and Eccentric classified network

TWO NEW developments US 23 & 9 Mile Rd lake frontlake access wooded walk out sites 1/4 acre paved streets 2 parks Brighton & Dexter Schools Owner (734) 663 4886

385 Mortgage/Land Contracts WHY RENT Own your own home 0 to 3% down Short term employment OK credit problems OK bankruptcy OK Call Randy Lesson Metro Finance 248-610 9576

387 Real Estate Wanted A BETTER PRICE for your home 0 to 3% down Short term employment OK credit problems OK bankruptcy OK Call Randy Lesson Metro Finance 248-610 9576

387 Real Estate Wanted A BETTER PRICE for your home Any condition all cash! 1 800 660 0904

CASH FOR YOUR HOME We buy Houses All types & conditions We can close very quickly Call Don Agent 734-458 6129

I BUY HOUSES! No Equity No Problem (248) 496-2336

I BUY & LEASE HOUSES any condition any price (734) 397 2630

NEW COMPANY LOOKING TO BUY OR LEASE HOUSES in Detroit Metropolitan area any price (248) 231 5144

388 Cemetery Lots CADILLAC MEMORIAL Gardens West 2 prime lot vaults included located in the Garden of The Last Supper \$2500 (313) 561 8366

GLEN EDEN Garden of Good Shepherd \$4200 (248) 565 4875

4 GRAVES located in Garden of Gethsemane in Cadillac Memorial Gardens West Best offer (231) 873 2376

NOVI MEADOWS On Napier Rd 1 mile S of Grand River 1 mile W of Wixom Rd Call John (248) 344-1988

IN WIXOM OWN A NEW HOME FOR \$321/MONTH PLUS \$2000 CASH BACK* New Homes Priced From the \$20's

3 bedrooms 2 baths GE appliances Skylights

NOVI Schools at KENSINGTON PLACE On Grand River 1.96 to exit 153 Across from Kensington Metropark Call Erin (248) 437-2039

IN NEW HUDSON OWN A NEW HOME FOR \$338/MONTH PLUS \$2000 CASH BACK* New Homes Priced From the \$20's

3 bedrooms 2 baths GE appliances Skylights

NOVI Schools at KENSINGTON PLACE On Grand River 1.96 to exit 153 Across from Kensington Metropark Call Erin (248) 437-2039

IN WIXOM OWN A NEW HOME FOR \$321/MONTH PLUS \$2000 CASH BACK* New Homes Priced From the \$20's

3 bedrooms 2 baths GE appliances Skylights

NOVI Schools at KENSINGTON PLACE On Grand River 1.96 to exit 153 Across from Kensington Metropark Call Erin (248) 437-2039

IN WIXOM OWN A NEW HOME FOR \$347/MONTH PLUS \$2000 CASH BACK* New Homes Priced From the \$20's

3 bedrooms 2 baths GE appliances Skylights

NOVI Schools at COMMERC MEADOWS on Wixom Rd 4 miles N of I-96 Call Kathy Snook (248) 684-6796

382 Lots & Acreage/Vacant ANNOUNCING TIMBERVIEW ACRES Low Down Payment Gentle rolling 2 1/2 acre sites some w/walkout basement your builder Easy access to western suburbs and Ann Arbor Financing Terms Available J A Bloch & Co/Gary Realty (248) 559 7430

BLOOMFIELD HILLS Lots available 4 acre to almost 4 acres We have both walk out and wooded lots Priced from \$395,000 Call Doug Keating at Snyder Kinney Bennett & Keating 248 644 7000 cell 248 330 9761

382 Lots & Acreage/Vacant BUILD YOUR OWN HOME Save \$1,000's 0% Construction Loan 1.5% down payment to start Pierson Gibbs Homes build the shell you finish it Any plan/size (800) 799 7417

HIGHLAND TWP 5 acres on Hickory Ridge near GM Proving Grounds Perked & surveyed \$147,000 (248) 505 8966

SALEM 3 lots available from \$70,000 \$150,000 South Lyon Schools Call Arnold Associates Inc (248)626 7557 Gary

SALEM TWP Approximately 2 acres in Salem Farms Estates Sub Cul de sac \$150,000 (248) 459 3391

SEARCH 1000's of Real Estate property listings at www.HomeTownLife.com Part of the Observer and Eccentric classified network

TWO NEW developments US 23 & 9 Mile Rd lake frontlake access wooded walk out sites 1/4 acre paved streets 2 parks Brighton & Dexter Schools Owner (734) 663 4886

385 Mortgage/Land Contracts WHY RENT Own your own home 0 to 3% down Short term employment OK credit problems OK bankruptcy OK Call Randy Lesson Metro Finance 248-610 9576

387 Real Estate Wanted A BETTER PRICE for your home 0 to 3% down Short term employment OK credit problems OK bankruptcy OK Call Randy Lesson Metro Finance 248-610 9576

387 Real Estate Wanted A BETTER PRICE for your home Any condition all cash! 1 800 660 0904

CASH FOR YOUR HOME We buy Houses All types & conditions We can close very quickly Call Don Agent 734-458 6129

I BUY HOUSES! No Equity No Problem (248) 496-2336

I BUY & LEASE HOUSES any condition any price (734) 397 2630

NEW COMPANY LOOKING TO BUY OR LEASE HOUSES in Detroit Metropolitan area any price (248) 231 5144

388 Cemetery Lots CADILLAC MEMORIAL Gardens West 2 prime lot vaults included located in the Garden of The Last Supper \$2500 (313) 561 8366

GLEN EDEN Garden of Good Shepherd \$4200 (248) 565 4875

4 GRAVES located in Garden of Gethsemane in Cadillac Memorial Gardens West Best offer (231) 873 2376

NOVI MEADOWS On Napier Rd 1 mile S of Grand River 1 mile W of Wixom Rd Call John (248) 344-1988

IN WIXOM OWN A NEW HOME FOR \$321/MONTH PLUS \$2000 CASH BACK* New Homes Priced From the \$20's

3 bedrooms 2 baths GE appliances Skylights

NOVI Schools at KENSINGTON PLACE On Grand River 1.96 to exit 153 Across from Kensington Metropark Call Erin (248) 437-2039

IN NEW HUDSON OWN A NEW HOME FOR \$338/MONTH PLUS \$2000 CASH BACK* New Homes Priced From the \$20's

3 bedrooms 2 baths GE appliances Skylights

NOVI Schools at KENSINGTON PLACE On Grand River 1.96 to exit 153 Across from Kensington Metropark Call Erin (248) 437-2039

IN WIXOM OWN A NEW HOME FOR \$321/MONTH PLUS \$2000 CASH BACK* New Homes Priced From the \$20's

3 bedrooms 2 baths GE appliances Skylights

NOVI Schools at KENSINGTON PLACE On Grand River 1.96 to exit 153 Across from Kensington Metropark Call Erin (248) 437-2039

IN WIXOM OWN A NEW HOME FOR \$347/MONTH PLUS \$2000 CASH BACK* New Homes Priced From the \$20's

3 bedrooms 2 baths GE appliances Skylights

NOVI Schools at COMMERC MEADOWS on Wixom Rd 4 miles N of I-96 Call Kathy Snook (248) 684-6796

382 Lots & Acreage/Vacant ANNOUNCING TIMBERVIEW ACRES Low Down Payment Gentle rolling 2 1/2 acre sites some w/walkout basement your builder Easy access to western suburbs and Ann Arbor Financing Terms Available J A Bloch & Co/Gary Realty (248) 559 7430

BLOOMFIELD HILLS Lots available 4 acre to almost 4 acres We have both walk out and wooded lots Priced from \$395,000 Call Doug Keating at Snyder Kinney Bennett & Keating 248 644 7000 cell 248 330 9761

PUBLISHER'S NOTICE All real estate advertising in this newspaper is subject to the Fair Housing Act which makes it illegal to advertise any preference limitation or discrimination based on race color religion sex handicap familial status or national origin or an intention to make any such preference limitation or discrimination. Family status includes children under the age of 18 living with parents or legal custodians pregnant women and people securing custody of children under 18. This newspaper will not knowingly accept any advertising for real estate which is in violation of the law. Our readers are hereby informed that all dwellings advertised in this newspaper are available on an equal opportunity basis. To complain of discrimination call HUD toll free at 1 800 669 9777. The toll free telephone number for the hearing impaired is 1 800 927 9275.

387 Real Estate Wanted A BETTER PRICE for your home Any condition all cash! 1 800 660 0904

387 Real Estate Wanted A BETTER PRICE for your home Any condition all cash! 1 800 660 0904

APARTMENTS

All Ads Run Online
FREE!
A Value Of Up To \$87 00

www.observerandeccentric.com

400's Real Estate For Rent

400 Apartments/Unfurnished	420 Halls/Buildings
401 Apartments/Furnished	421 Res. den. To Exchange
402 Condos/Townhouses	430 Garage/Mini Storage
403 Duplexes	440 Wanted To Rent
404 Flats	441 Wanted To Rent
405 Homes	450 Resort Property
406 Lakefront/Waterfront	456 Furniture Rental
407 Homes Rental	458 Rental Agency
408 Mobil Home Sites	457 Property Management
409 Southern Rentals	459 Lease/Option To Buy
410 Time Share Rentals	460 House Sittng Service
411 Vacation Resort/Rentals	460 Convalescent/Home
412 Living Quarters To Share	461 Health Care
414 Rooms	461 Foster Care
	464 M.sc To Rent

1-800-579-SELL

Real Estate for Rent

#400-498

400 Apartments/Unfurnished

ALLEN PARK

Hampton Square Apartments
Security Deposit*
1 & 2 bedrooms
Free Heat
Storage & Laundry
Walk in closets
Starting at \$540
(313) 274-3675
*conditions apply

400 Apartments/Unfurnished

WESTBURY VILLAGE TOWNHOUSES

Savings of up to \$2400!
On 2 or 3 bedroom townhouses
2 1/2 baths
washer/dryer included
covered parking
Sparkling pool
Tennis courts
over 1500 sq ft
starting at \$1160
248-852-7550 x418
OPEN 7 DAYS
*conditions apply

Berkley O Security Deposit*

Immediate occupancy!
1 bedroom apartment
\$810/Month
FREE HEAT
1 1/2 Mile/Coolidge area
(248) 544-7715
*with approved credit

BIRMINGHAM 1100 sq ft 2 bedrooms 1 1/2 baths Corn pletely updated pool & near park \$1300/mo 248-637 0085

BLOOMFIELD GUEST HOUSE on pool Spacious 1 bedroom All appliances \$750/mo (248) 789-2335

BLOOMFIELD HILLS Beautiful 1 & 2 Bedroom Apart ments starting at \$850/month Exceptional Service Pets wel come Free heat
Whitersfield 248 645 0026

CANTON BEDFORD SQUARE APTS

NOW TAKING APPLICATIONS FOR Spacious 1 & 2 Bedroom Apts Small Quiet Safe Complex Ford Road near I 275
STARTING AT \$585 (734) 981 1217

Canton \$300* rebate Spacious 2 Bedroom 2 level apartments elementary school across the street
1 bedrooms from **\$565**
CANTON GARDEN APARTMENTS (734) 455-7440
Sorry No Pets Short term leases available
*New residents only

400 Apartments/Unfurnished

CANTON Carriage Cove Luxury Apts

(LILLEY & WARREN)
We take pride in offering the fol lowing services to our tenants
• Private entry
• Emergency maintenance
• Beautiful grounds with pool & picnic area with BBQ's
• Special handicapped units
• Restful atmosphere
• Cable available
• Many more amenities
NO OTHER FEES
• 1 bedroom \$665 900 sq ft
• 2 bedroom \$735 1100 sq ft
• Vertical blinds & carpet included
• Ceramic bath & foyer
• Professional on site management
• 23 plus years experience
• Near x ways shopping airport
Rose Doherty Property Manager (734) 981 4480

CANTON FRANKLIN PALMER Apartments

One Bedroom Special MAY RENT FREE
Free Heat
Sound Condit ioned Central Air
www.apts.com/franklinpalmerapts
888-736-8469
*Limited Time Only with new 12 mo lease

Dearborn Heights Dearborn Club Apts.

One Bedroom Apts
Two Bedroom Townhomes
FREE HEAT
Spacious Floor Plans
Tons of Closet Space
Minutes from shopping
Patios & Balconies
1 1/2 baths in townhomes
www.apts.com/dearbornclubapts
(888) 348-7431
Located on Inker Rd just North of Ford Rd
Open Mon Sat
Call or Stop In

FARMINGTON AREA Senior citizen apt 55 yrs plus Private entry 1100 sq ft quiet \$690/mo Cal Jeff 734-421 3515

FARMINGTON HILLS WALNUT CREEK APTS 1 Bedroom SPECIAL Starting from \$560/mo 248 473 1395

FARMINGTON HILLS MAPLE RIDGE APTS 23078 Middlebelt Rd 1 2 bedroom central air \$565/\$665 248 473 5180

400 Apartments/Unfurnished

GRAND RIVER MIDDLEBELT

Great Location
Near Botsford Hospital
Livonia Mall and Downtown Farmington with Clarenceville School District
CEDARIDGE
2 Bedroom Units
From \$705
Vertical blinds carpeting
Hoipoint appliances security system storage within apt
Ask about our limited time special
Enter on Tulane 1 block W of Middlebelt S side of Grand River
Model Open Daily 16 Except Wednesday
248 471 5020 586 775 8206

Best Apartment Value
FARMINGTON HILLS
(N on Tuk Rd off 8 Mile between Middlebelt & Orchard Lake Rd corner of Folsom)
TIMBERIDGE APARTMENTS
Deluxe 1 & 2 Bedroom Units
From \$620
Ask about our limited time special
Includes appliances vertical blinds carpeting pool optional carports
Model Open Daily (9 5)
Rental Office 248-478 1467
Home Office 586 775 8206

Farmington Hills FOXPOINTE TOWNHOUSES

Savings of up to \$2480!
On 2 bedroom townhouses
2 1/2 baths
washer/dryer included
covered parking
Sparkling pool
Tennis courts
over 1456 sqft
starting at \$1225
Call 248 473 1127 x418
OPEN 7 DAYS
*conditions apply

Farmington Hills SUMMIT APARTMENTS

2 bedroom 2 baths
washer/dryer included
covered parking
Sparkling pool
Tennis courts
Clubhouse for entertaining
over 1350 sqft
starting at \$1110
248-626-4396 x418

FARMINGTON HILLS Luxury apts available Washer/dryer in unit 1 bedroom \$555 Cal 586 254 9511

FARMINGTON HILLS 9 M e/ M dd ebelt 1 bedroom at \$495 includes heat appliances car peting 248 478 7489

Farmington Hills HAPPINESS IS Moving into a cozy 1 bedroom apartment Verticals & Carpet included Starting at \$570 Cedarbrooke Apts 248-478 0322

400 Apartments/Unfurnished

Farmington Hills SUPER LOCATION

Grand River/Orchard Lake
STONERIDGE MANOR APARTMENTS
Enter off Freedom Road W of Orchard Lake Road South of Grand River
Deluxe 1 bedroom
Starting at \$630
Ask about our limited time special
Includes Patio or balcony
carpeting vertical blinds
deluxe appliances and
FREE carpet
Mon - Fri 1 00 8 00
Rental Office (248) 478 1437
Home Office (586) 775-8206

FARMINGTON SPECIAL

Deluxe 1 bedroom & studio
apartments starting at \$500 per mo
carports 248 888 0868

Franklin Area Weatherstone Townhouses

Savings of up to \$1755*
On 2 & 3 bedroom townhouses
2 1/2 baths
washer/dryer hookup
2 car attached garage
Sparkling pool
1700 sqft
starting at \$1575
248 350 1296 x418
OPEN 7 DAYS
*conditions apply

GARDEN CITY

Ford/Middlebelt Area
Spacious 1 bedroom Apts
Amenities Include
• Owner Paid Heat & Water
• Central Air
• Intercom System
• Garbage Disposal
• Laundry Facilities
• Window Treatments/
Mini Blinds
FROM \$510 MONTHLY
GARDEN CITY TERRACE
(734) 522 0480

GARDEN CITY 2 bedroom new appliances remodeled front patio balcony air heat/water included 248 474 3005

GARDEN CITY Ford/Mer rman Small building 1 bed room heat water & wash free \$500 + security 313 274 4822

HIGHLAND TOWERS APARTMENTS 55 & older community 1 bed room apts available From \$521 \$551 gas & water included Near shopping restau rants etc Please Call (248) 569 7077

LIVONIA 2 bedrooms 2 baths carpet blinds & carpet throughout Also 1 bedroom available (248) 442 1350

Lvonia **CURTIS CREEK APTS**
Farmington at 6 1/2 Mile Rd
Spacious 1 & 2 bedroom 1 1/2 bath units Private entrance washer/dryer patio/balcony pets allowed park like set ting immediate occupancy 248 473 0365

400 Apartments/Unfurnished

One of Livonia's finest apartments at competitive prices
CANTERBURY PARK APARTMENTS
19400 Mayfield off Seven Mile Rd between Farm ington & Merriman Roads behind Joe's Produce
1 & 2 Bedroom
2 Bath Units
Starting at \$715
Immediate Occupancy
Ask about our limited time special
Includes full washer & dryer in each apartment
Community room patio or balcony deluxe appli ances optional carport
248 473 3983
586 775 8206

LIVONIA'S FINEST LOCATION

MERRIMAN WOODS APTS

Merriman Rd corner of 7 Mile Near Livonia Mall
Deluxe 1 & 2 Bedrooms 2 Baths
Starting at \$695
Ask about our limited time special
Includes Patio or balcony
carpeting vertical blinds
deluxe appliances pool
248 477 9377
586 775 8206

GREAT APARTMENTS

Rent Includes Heat and Vertical Blinds
6 month or 1 year lease
Well maintained
Newly decorated
Features
• Air conditioning
• Refrigerator and range
• Smoke detectors
• Laundry facilities
• Extra storage
• Swimming pool
• Cable available
1 & 2 Bedroom Apts. LEXINGTON VILLAGE
Small Pat Section
From \$540
1 75 and 14 Mile opposite Oakland Mall
248-585-4010
PRESIDENT MADISON APTS.
From \$585
1 block east of John R just south of Oakland Mall
248-585-0580
HARLO APTS.
From \$555
Warren MI West side of Mount Rd just north of 13 Mile Opposite GM Tech Center
586-939-2340

Northville Unique Two-Story Lofts

Live by the river and amidst the trees in these pretty two story one bedroom apartments from only \$715 Covered parking wooded streamside setting personal service and ducks included! EHO
All this and One Month Free!
THE TREE TOPS
Novi Rd at 8 Mile
(248) 347 1690

W. BLOOMFIELD

\$0 Security Deposit Special
on Selected Floor plans
Orchard Lake & Middlebelt
BLOOMFIELD ON THE GREEN
Available
248-682-2950
OPEN 7 DAYS • MON THUR 9am-5pm • FRI 9am 7pm • SAT 9am-5pm • SU

CHIMNEY HILL APARTMENTS

OPEN HOUSE
Saturday, April 27th 10am-2pm
Chimney Hill Apartments
Beautiful Condo Style Luxury Apartme Homes at Amazing Rates! One Day On

NOVI WATERVIEW FA Apartments

On Pontiac Trail betw West and Beck
\$300 OFF
1st MONTH'S R
2 BEDROOM AP
New move-ins on
Pool
Patios/Balconies
www.apts.com/watervie
248-624-01
MF 9-6 S

Novi Affordable LU FOUNTAIN P OF NOVI

Spring Spec
3 Months FREE REN
*New residents
• Private Entrance
• Washer & Dryer
• Novi Schools &
10 30-6 30 Mon
12 5 Sat & Su
On Grand River betw Meadowbrook & M (helly) Chevrolet
42101 Fountain Pa
248-348-062

Novi More Space Less Money

Extremely large 2 bed bath apartments feat cious rooms and close sized patios/balconies kitchens vertical blinds air most with carpo area's best value in \$750 EHO
ASK ABOUT C SPECIALS!
FREE TOP MEAL 10 Mile & Meadow (248) 348 959

Novi Townhome ABSOLUTE THE BEST

2 FREE Month (apartments)
Huge 3-bedroom Townhomes From \$849
• Full Basements
• All Pets Welcome
• Covered Parking
• Fitness Center
• Modern Kitchens
Call Toll Free (877) 329-222 offer ends 4/30/02
*Restrictions App

★ MOVE-IN NOW! SECURITY DEPT SPECIAL!

Newly upgrad 1 & 2 Bedroc
Plymouth Hill
Plymouth Hill Available!
Close to Downt Plymouth!
734-455-38
PLYMOUTH 1 bedroc included Quiet building at \$525 per month 1 yr Available now 734 4

Classifieds Work!

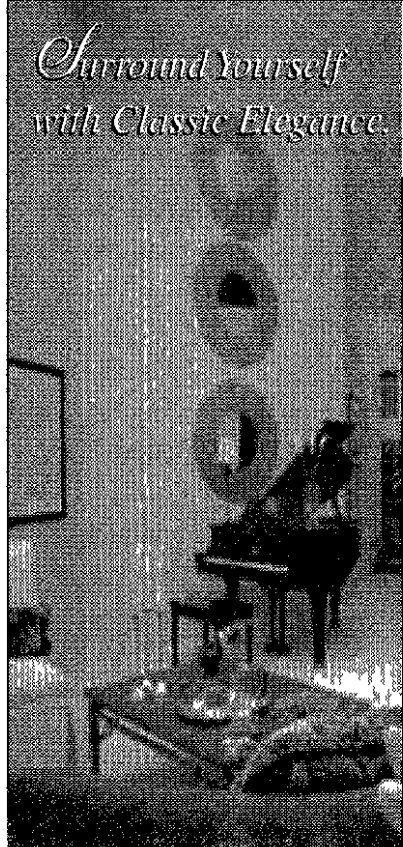

Join us at our **OPEN HOUSE**
April 27th from **11:00am - 5:00pm**

Aldingbrooke

- Beautiful rolling hills and picturesque views.
- 24 HR attended gatehouse
- Up to 2800 sq. ft. of living space
- 2 car attached garage on select apartments
- Full size washer & dryer included
- Furnished executive rentals
- Pets welcome
- Perfectly located in prestigious West Bloomfield

(248) 661-0770
6350 Aldingbrooke Circle Rd. North West Bloomfield
(On Drake Rd. between Maple & Walnut Roads)

Luxury Apartment Living

Auburn Hills ADAMS CREEK apartments

1 & 2 bedroom apartment homes
Washer and Dryer
Close to shopping/dining and entertainment
From \$785* a month
(248) 853-5599
On Adams Rd between South Blvd and Auburn Rd

Novi SHOREBROOKE

Spacious 2 & 3 bedroom townhomes
Attached garage or basement
Close to shopping/dining and entertainment
Excellent Novi schools
From \$1245* a month
(248) 471-7470
Located on Haggerty Rd South of 10 Mile Rd

Canton SUMMIT CREEK

Luxury 1 & 2 & 3 bedroom apartment homes
1 & 2 car attached garages
Plymouth/Canton Schools
From \$1095* a month
(734) 398-5300
Located on Canton Center Rd North of Mich Ave

Novi Wexford

2 & 3 bedroom townhomes
Full basement or finished walk-out
Close to Twelve Oaks Mall and Novi Town Center
From \$1295* a month
(248) 669-1050
At the corner of Novi Rd and 13 Mile Rd

Canton WYNDCHASE

Spacious 2 & 3 bedroom townhomes and apartments
1 & 2 car garages
Plymouth/Canton Schools
From \$1095* a month
(734) 844-2400
Northeast corner of Cherry Hill & Haggerty Rd.

Novi MAIN STREET VILLAGE

1 2 3 & 4 bedroom apartments and townhomes
Attached 1 or 2 car garage
Excellent location in downtown Novi
From \$1195* a month
(248) 349-8400
Located off Grand River at Novi Rd.

Commerce/Novi BRIARCLIFF VILLAGE

1 2 & 3 bedroom apartment homes
1 & 2 car attached garages
Close to Novi Town Center and Twelve Oaks Mall
From \$895* a month
(248) 669-5900
On 14 Mile Rd East of Novi Rd

Rochester Hills NORTH RIDGE

1 & 2 bedroom terraced apartments and townhomes
Fireplace in select homes
Close to shopping dining & entertainment
From \$795* a month
(248) 651-1091
Located on Avon Rd between Rochester Rd and Livernois Rd

Downtown Northville MAIN CENTRE

Luxury 1 & 2 bedroom & loft apartments
Covered Parking
From \$945* a month
(248) 347-6811
At the corner of Main and Center Streets, Northville

West Bloomfield CANTON

Luxury 2 & 3 bedroom apartment homes
Attached garage
Easy access to I 696 & M 5 connector
From \$1295* a month
(248) 661-5870
On 14 Mile Rd just West of Halsted

SINGH

A Tradition of Excellence
www.singhproperties.com

2 Bedroom as low as \$555 SPRING FORWARD

For Savings on a New Apartment Home

WILLOW CREEK APTS.

1 & 2 BEDROOM APTS.
Air conditioning — Window Treatments
Family picnic area with grills
1673 Fairwood — Westland
(South of Ford Road off Newburgh)
(734) 728-0630
www.apartments.com
*New Residents only on select units
Offer good through 4/30/02. Some restrictions may apply.

Act Now! Limited Availability. Adults 55+

Ready, Set, Move!

You can enjoy active apartment living that's affordable, too. It's all possible at The Meadows of Livonia—the affordable community for adults 55+. Make your move today to our spacious apartments. Call or visit and learn more about the senior apartment community that's easy to call home!

1 & 2 BEDROOM FLOOR PLANS STILL AVAILABLE!

The Meadows of Livonia

Senior Apartment Community

734/522-1151
28811 Jamison
Livonia, MI 48154

- Heat included
- Carports available
- Fully equipped kitchens
- Elevator service
- Laundry room on each floor
- Social, education, and recreational programs

CHIMNEY HILL APARTMENTS

OPEN HOUSE
Saturday, April 27th 10am-2pm
Chimney Hill Apartments
Beautiful Condo Style Luxury Apartme Homes at Amazing Rates! One Day On

Directions From Orchard Lake Rd turn west Maple Travel 1/4 mile and turn south on Daly Chimney Hill is located on the right behind the Power House Gym
Phone: 248-737-4510 or Fax: 248-737-4
www.marquettmanagement.com

APARTMENTS

All Ads Run Online FREE! A Value Of Up To \$87 00

www.observerandeccentric.com

400 Apartments/Unfurnished PLYMOUTH HILLCREST CLUB Apartments 1 MONTH FREE* Call For Special Prices FREE HEAT

400 Apartments/Unfurnished Spring Forward! Come in and see us and well Spring for a good deal!

400 Apartments/Unfurnished WALLEE LAKE Area Hawk Lake Apts 12 Bedrooms and townhouses Lake privileges fishing balconies central air

400 Apartments/Unfurnished Westland EARLY SPRING SPECIAL • New residents only • 1 bedroom from \$550

400 Apartments/Unfurnished Westland OUT OUR SPECIALS \$\$\$\$\$\$ One & Two Bedrooms • Free Heat

402 Condos/Townhouses BIRMINGHAM FIRST floor 2 bedroom 2 bath renovated condo Furnished \$2 250/mo

402 Condos/Townhouses CLAWSON Near 14 Mile & Crooks Minutes to Somerset & Birmingham

402 Condos/Townhouses NOVI Single bedroom condo \$650/mo plus security includes heat Available now 10 Mile & Haggerty area

402 Condos/Townhouses WEST BLOOMFIELD Two Units 2 bedroom 2 bath or 3 bedroom 2 bath Drake & Maple area

PLYMOUTH Lower 1 spacious bedroom c/a all appliances carpet \$650/mo + security

A SPECIAL PLACE to Call Home Park Lane Apts 248-355-0770 paragonapartments.com

\$499 MOVES YOU IN 1 & 2 Bedroom Apts 1 Bedroom Starts at \$575 2 Bedroom Starts at \$625

Westland Forest Lane Apartments Studio \$500 1 Bedroom \$600 2 Bedrooms \$650

Westland Park Apts Across from Garden City Park Spacious 2 bedroom 1 1/2 bath 936sq ft

BIRMINGHAM MAPLE Between Adams & Eton Walk to downtown from these charming 1 and 2 bed room townhomes

LIVONIA CONDO 1 bedroom pool laundry carport heat included immediate occupancy \$625/mo

ROCHESTER FRESHLY painted sharp 1 bedroom ranch condo with view of pool heat included \$775/month

PLYMOUTH NEWLY remodeled 2 bedroom with usable basement Nice yard privacy fence \$925/mo

PLYMOUTH PARK APTS 40325 Plymouth Rd near I 275 1 bedroom from \$590 2 bedroom from \$630

Southfield Colony Park Twyckingham Apartments 1 & 2 bedrooms Immediate Occupancy

SPRING SPECIAL WESTLAND CAPRI California Style Apts • 1 bedroom from \$550 • Heat & water included

Westland GLEN ARMS APTS 34630 Glenwood E of Wayne (Under New Management) 1 Bedroom starting at \$530

Westland Park Apts Large 1 bedroom 700sq ft From \$555 \$200 Security Deposit with approved credit

BIRMINGHAM/TROY Newly constructed 2 bedroom 2 1/2 bath townhouse Close to Somerset & Birmingham

NOVI Brand New Condo For Rent 3 bedroom with first floor master 2 car private attached garage

WEST BLOOMFIELD 2100sqft 2 bedrooms office 2 1/2 baths open dining/living fire place

PLYMOUTH SQUARE APTS Spacious 1 bedroom 825 sq ft air conditioning window treat ments \$640

PLYMOUTH Studio apt \$100/wk utilities included 1 Bed room \$150/wk utilities included

Southfield 1 MONTH FREE Free Heat & Water Central Air 2 & 3 Bedroom Apts

WESTLAND HAWTHORNE CLUB APARTMENTS On Mermaid between Ann Arbor Trail & Wayne

WESTLAND WAYNE/FORD RD AREA • Heat & Water Included • Spacious Floor Plans

401 Apartments Furnished Birmingham • Novi Royal Oak • Troy Furnished Apts

BRIGHTON SPACIOUS luxury 3 600 sq ft 5 bedroom 3 bath fireplace appliances 1 mile to 96/major shopping

CANTON Beautiful 3 bedroom Townhouse basement carport AC new appliances \$1400/mo

WEST BLOOMFIELD 2100sqft 2 bedrooms office 2 1/2 baths open dining/living fire place

PLYMOUTH PARK Manor Apartments 1 bedroom \$555 includes heat & water No pets 1 parking space/apt

ROCHESTER HILLS 12-HOUR SALE! APRIL 25th 9AM 9PM FANTASTIC SPECIALS! WIN A DVD PLAYER

Southfield STONEBROOKE TOWNHOUSES 26361 Franklin Pointe Dr Corner of Franklin & Beck Rd

WESTLAND HUNTINGTON ON THE HILL On Ann Arbor 1/2 mile west of I-196

Westland Open Sunday \$ GREAT \$ SPRING \$ SAVINGS \$ 2 bedrooms \$450*

CANTON 1 bedroom Country setting Non smoking apartment \$60/mo plus security deposit

FARMINGTON HILLS Park Hotel Furnished rooms efficient & apt's from \$150/week

NOVWALLEE LAKE area furnished efficiency apt \$150/wk \$600/mo Call Randy the Realtor

ROYAL OAK DOWNTOWN Fully furnished Studio \$500/mo Plus security deposit

ARMENIAN Senior Citizen Tower located in Dearborn offers: Spacious (1) Bedroom Apartments for Immediate Occupancy!

ROCHESTER HILLS 12-HOUR SALE! APRIL 25th 9AM 9PM FANTASTIC SPECIALS! WIN A DVD PLAYER

Troy Three Oaks Apts. SPECIAL! \$1,000 OFF RENT For Limited Time

Westland Barclay House Apts Extra large 1 bedroom Quiet clean Air heat appliances included

Westland VENOY PINES APARTMENTS 1 & 2 bedroom apts some with fireplace Clubhouse

BIRMINGHAM 2 bedrooms 1 1/2 baths large kitchen living & dining room w/den air base ment pool new neutral decor

BIRMINGHAM 2 bedrooms 1 1/2 baths large kitchen living & dining room w/den air base ment pool new neutral decor

VILLAGE SQUIRE APARTMENTS 5955 Edinburg, Canton, MI 48187 2 blocks East of I-275

DEARBORN HEIGHTS AREA Beautiful 1, 2 & 3 Bedroom 2 BEDROOM, 2 BATH VILLA

Northville-Great Location * SPECIAL OFFER * FREE Enrollment to Lifetime Fitness!!!

ROYAL OAK Large 1 bedroom across from Beaumont Hospital Private parking \$675/mo

WALLEE LAKE area 1 bedroom with 4th room for computer/home office Quiet non smoking building

Westland Affordable Luxury Spring Special 3 months FREE RENT!!!

Franklin Square Apartments • FREE Heat & Water • Professional Staff • Great Livonia Location

402 Condos/Townhouses BIRMINGHAM 2 bedrooms 1 1/2 baths large kitchen living & dining room w/den air base ment pool new neutral decor

BIRMINGHAM 2 bedrooms 1 1/2 baths large kitchen living & dining room w/den air base ment pool new neutral decor

WAYNEWOOD Apartments • Huge 1 & 2 Bedrooms from only \$600! • Free Heat & Water • Private Patio or Balcony

DEARBORN NEWLY remodeled 2 bedroom with usable basement Nice yard privacy fence \$925/mo

Concord Towers MADISON HEIGHTS/TROY/ROYAL OAK Experience the Quiet, Convenience and Affordability of Concord Towers Apartments

We're a whole lot closer to home. Families have found some of the best things in our hometown classifieds Like this really great canoe in the Birmingham Eccentric or that great dog advertised in the Canton Observer

We're BIG on Square Feet Huge Apartments & Town Homes from \$795 Country Corner 30300 Southfield Road

Westland's Best Value... BLUE GARDEN APARTMENTS \$250 Off First Months Rent, 1 Bedroom Unit

Concord Towers Apartments OFFICE HOURS: Mon-Fri 10-5 • Sat 10-1 (248) 589-3355 32600 Concord Dr. • Madison Heights

THE MICHIGAN GROUP

OPEN SUNDAY, APRIL 28



BRIGHTON 1-4 PM
115 W PETERSON
Hostess Carol Clark, Ext 395
3 BR 1 BA N of Hynes/E of Old US 23
Hartland schools & lake privileges
Updated kit BA & many more updates
Attached garage deck & huge parklike
backyard Adorable & affordable \$154 900



BRIGHTON 2-5 PM
10688 HICKORY KNOLL
Host/Hostess David Miller, Ext 247
Nancy Hubbell, Ext 217
3 BR 2.5 BA 2 tree acres great sub prime
location FP cuth ceiling in GR oak floors, 3 car
gar deck CA sprinkler sec syst \$6 to Plant
Valley N to Spencer left to Van Amberg R right
to Woodfield \$362 900

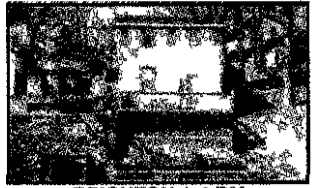

BRIGHTON 1-4 PM
6209 ISLAND LAKE DRIVE
Host David Moon, Ext 641
3 BR 2 BA Just in time for Summer fun
Come and enjoy lakelakefront living on all
sports Island Lake Take Grand River
East to Superior to Coventry to Island
Lake Drive MLS#22024854 \$236 500



BRIGHTON 1-4 PM
4468 GOLDFVIEW
Hostess Bonnie David, Ext 347
3 BR 3.5 BA Oak Pointe Condo over
3000 sq ft living area Finished walk
out Premium Honors Golf Course
site Brighton Rd to Oak Pointe Drive
to 4468 Golfview \$349 900

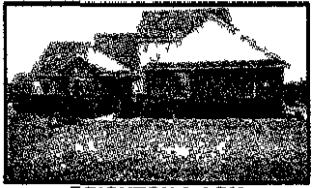

BRIGHTON 2-4 PM
2108 ORE CREEK LANE
Hostess Linda Auen, Ext 353
3 BR 2.5 BA Grand River West to
Hacker E on Hynes to Eastpointe
1.5 story 1st floor master Hardwood
floors & ceramic New screened
porch deck and patio \$299 585



BRIGHTON 2-5 PM
11136 CLOVERLAWN
Hostess Carmen Samples Ext 332
Beautiful home on lovely wooded acre lot
in great sub Home features 4 BR 2.5 BA & 2
car att garage Spacious home One year
home warranty Take Spencer Rd to Van
Amberg North to Cloverlawn \$344 900

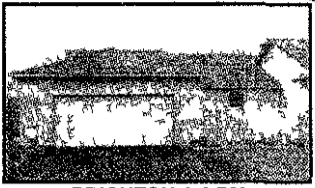

BRIGHTON 1-4 PM
3016 EAST TELLURIDE
Hostess Fran Heing, Ext 218
3 BR 3 BA Beautiful condo in Brighton
schools 2 sets of double French doors lead
ing to delightful sunroom Fin walkout Grand
River S to Breckenridge to East Telluride
(Lake Edward Townhouses) \$224 900



BRIGHTON 1-4 PM
7026 LINDSEY
Hostess Nan Gregory, Ext 245
3 BR 2 BA Beautiful rustic 1.5 story Vaulted
GR lots of windows huge master BR Must
see Take I 96 to Grand River W right toward
Howell) to Hubert left to house (Corner of
Lindsey & Hubert) MLS#2109058 \$289 000

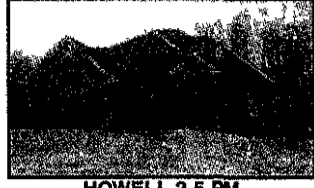

HOWELL 2-5 PM
4254 SUNDANCE MEADOWS
Host Jeff Stamm, Ext 225
4 BR 3 BA Spectacular 3000 sq ft home on
wooded acre lot Big 2 story GR w/gleam
view into woods Marble master BA big
family kit & formal dining rm 3 car garage
D19 go W on Coon Lk Rd \$444 900



BRIGHTON 12-3 PM
1790 EULER RD
Hostesses Vicki Loveland/
Patty Furlington, Ext 266/300
3 BR 3.5 BA If you want privacy this is the
home for you! In Brighton just off Grand River
on over 4 acres all wooded Large brok
ranch walkout w/extra 4 car gar \$280 000

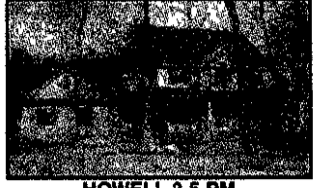

HOWELL 2-5 PM
LOT 59 SUNDANCE CROSSING
Host Jeff Stamm, Ext 225
4 BR 3 BA Big family home w/wrap around
front porch sitting in the woods w/9 car
garage big bonus rm over garage 3 sea
son rm off back & wonderful trim package
D19 go W on Coon Lk Rd \$429 900



HOWELL 2-5 PM
1963 SUNDANCE RIDGE
Host Jeff Stamm, Ext 225
4 BR 3 BA Ready for occupancy 2740 sq ft
landscaped new deck 3 car garage & out
building permitted on lot All the extras
even central vac I Take D19 to Coon Lake
Rd go W 1/2 mile to Sundance \$354 900



HOWELL 1-3 PM
2309 HICKORY CIRCLE DRIVE
Hostess Terri Park, Ext 337
Immaculate ranch 4 BR 3 full BA Many
updates FR w/beautiful limestone FR w/brato
door opening to nice deck lg master BR kit
has lots of oak cabinets A must see! On N
side of M59 bwn Eager & Mich Ave Hickory
Hills Blvd to Hickory Circle left \$229 900

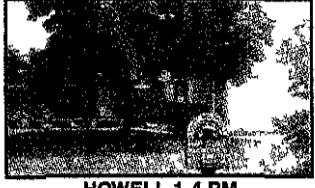

HOWELL 1-4 PM
8080 PINE RANCH
Host Nick Natoli, Ext 278
3 bedroom 3 bath All sports Woodland
Lake! 84 ft of frontage beautiful hilltop
view 2 fireplaces 2 car garage 1 year
home warranty & more East of Hacker
North of Grand River \$359 900

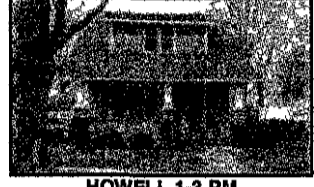

HOWELL 1-3 PM
348 E BROOKS STREET
Hostess Terri Park, Ext 337
Ideal large family home 4 BR 1 BA all
Cape Cod on over 1 acre Take M 59 to
Oak Grove North to Marr left
Grand River to Mich Ave S to E Brooks
to house MLS#22021561 \$170 950

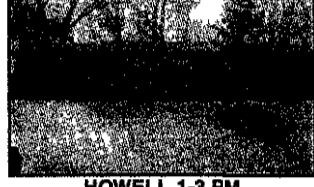

HOWELL 1-3 PM
5805 CRANDALL
Hostess Terri Park, Ext 337
Nice 3 BR 2 BA ranch w/pretty deck overlooking
lovely landscaped backyard Walkout
walkout basement For pests & quiet take
Oak Grove Rd North of M 59 3 miles to
Marr Rd go West 6/10 mile \$229 900

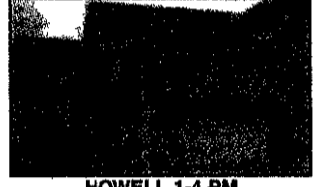

HOWELL 1-4 PM
644 OLDE IVY LANE
Hostess Bonnie David, Ext 347
3 BR 2.5 BA New construction! Golf
course frontage many to choose from
Upgrades galore included Free bonus
room on select models. Must see! Enter
Covington Greens off Hughes Rd between
Golf Club & Grand River \$216 900

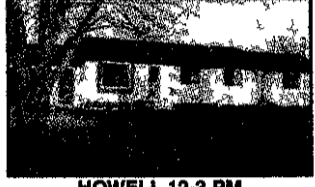

HOWELL 12-3 PM
7910 WIGGINS RD
Host Tony Jekira, Ext 311
3 BR 2 BA Take Latson Rd N to
Faussett turn left to Wiggins right 1
mile N 2 11 acres completely remodeled
in last 5 years 2.5 car attached &
3.5 car detached garage \$209 900

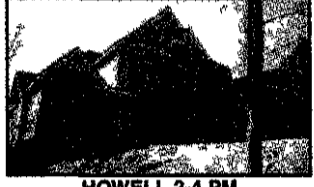

HOWELL 2-4 PM
2877 BLACK EAGLE
Hostess Dina Sabuda, Ext 251
4 BR 2.5 BA Over 2500 sq ft 10 ceilings in
nook & kit 2nd FR in sitting rm 1st floor
master suite walkout bent brick & wood
exterior 2 story GR ceramic BA top qual
ty thru-out 60 days to complete \$348 500

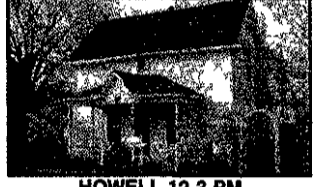

HOWELL 12-3 PM
234 E WASHINGTON
Host Brad Fletcher, Ext 256
3 BR 2 BA Completely remodeled Pergo &
hond fine custom wood trim new lot counters
cabinets ceramic tile cement deck & newer vinyl
siding & windows 90% eff furnace 1st fr mas
ter C/A Grand River to Mich S to Washington
E to home MLS#22014082 \$147 500



HOWELL 1-30-4-30 PM
1037 PEAVY
Hostess Eileen Crockett, Ext 319
3 BR 2 BA Nicely decorated home Over
1/2 acre lot w/mustache fence Updated
kitchen in oak & white ceramic tile Partly
finished basement Close to town &
expressway Home warranty

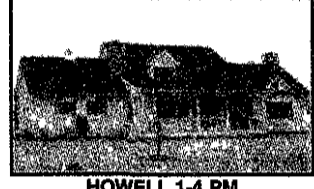

HOWELL 1-4 PM
4605 PRESTON
Host Carl Vagnetti Ext 253
4 bedroom 2.5 bath Classy Cape
Cod on over 1 acre Take M 59 to
Oak Grove North to Marr left
(West) to Preston \$236 000

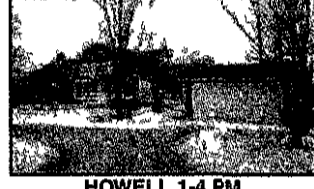

HOWELL 1-4 PM
1315 MARR RD
Host Randy Meek, Ext 220
This 5 acre country home beckons you!
1949 s f 4 BR 2 BA with partially finished
walkout basement For pests & quiet take
Oak Grove Rd North of M 59 3 miles to
Marr Rd go West 6/10 mile \$229 900

SOLD • SOLD • SOLD

LIVINGSTON

THE MICHIGAN GROUP

REALTORS

Your LIVINGSTON COUNTY BROKER

michiangroup.com

6870 GRAND RIVER

BRIGHTON

227-4600

360

hometour



HARTLAND 1-4 PM
UNIT 21 AUGUSTINE COURT
Hostess Bonnie Lane/
Christine Migliore, Ext 207
3 BR 2.5 BA New 2 story on 1 acre hilltop lot Pole
barn allowed Fast incl cathedral ceilings 90%
eff furnace oak Mantel cabinets tile BA formal
DR & custom lib M59 to N on Argentine E on
Faussett N on Green to Augustine Ct \$249 900



HARTLAND 2-4 PM
1919 WOODMAR
Hosts Strang - Leabu Ext 252
3 bedrooms 2 baths M 59 West of
US 23 2 1/2 miles turn left onto
street \$254 900

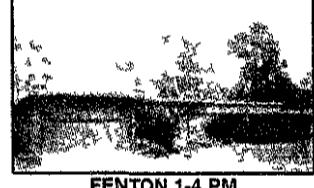

FENTON 1-4 PM
8011 DRIFTWOOD DRIVE N
Hostess Maureen J Hennig Ext 260
4 BR 2.5 BA Private all sports Lake
Shannon privileges Hartland schools
Spacious contemp ranch 20x18 master
ste 8x10 walk in closet 21x20 FR 2 gas
FP CA 2 miles W of US23 on Center S on
O Connell to Driftwood N \$235 000



FOWLERVILLE 12-3 PM
479 DAILEY COURT
Hostess Elaine Hawkins Ext 250
3 BR 2 BA From Grand River turn S on
Coonlake go to end curve left at also sign turn
left on Dailey Ct Beautiful 1428 sq ft handicap
friendly ranch Open floor plan cathedral cel
ing FP 1st floor laundry CA full bsmt cul
de sac location 2x6 construction \$187 900



SOUTH LYON 1-4 PM
59760 PETTINGILL
Host Bill Widmyer, Ext 325
3 BR 1.5 BA Over an acre of land with a
full back porch Finished basement and an
attached hot tub room great for year round
enjoyment Located just West of Milford
Rd off Grand River \$269 900

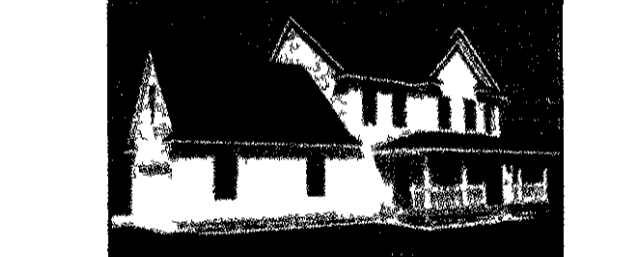

HOWELL 1-4 PM
4861 N LATSON
Hostess Joan Petrose
New construction 3 bed 2.5 bath first floor master
suite Walkout lower level Over 1 acre lot 2400 sq ft

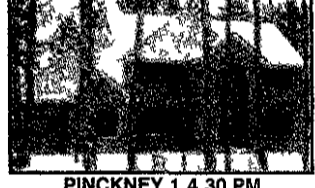

PINCKNEY 1-4-30 PM
4387 EMU DRIVE
Host Bill Mathers Ext 201
3 bedroom 2+2 lavs In the pines of
gorgeous Putnam Meadows Sub The
new Colonial overlooks the trace fair
way at challenging Timber Trace Golf
Club (MLS#21036529) \$339 900

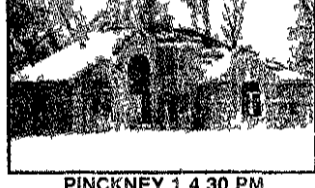

PINCKNEY 1-4-30 PM
4668 EMU DRIVE
Host Bill Mathers Ext 201
4 bedroom 2.5 baths New const ac on
1400 sq ft ranch with 1200 sq ft over
level 3 BR 2 BA C/A new windows & roof
first floor laundry fenced backyard 2.5 car
garage M 36 to Whitewood to Crystal to
Hill to Macomb MLS#22027790 \$186 500

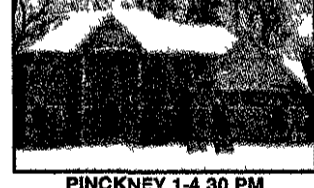

PINCKNEY 1-4-30 PM
4696 EMU DRIVE
Host Bill Mathers, Ext 201
4 bedroom 3.5 baths Stately Colonial
with 1400 sq ft ranch on 2.5 acres
at Timber Trace Golf Club Unique octagon
breakfast area and sitting room in master
suite 3 car attached garage \$379 900



PINCKNEY/HELL 1-4 PM
5767 ELVIRA
Hostess Renee Pasko, Ext 687
2+ bedrooms 2 bath Lakelakefront w/association
common land All sports lake W to University
Camp left to Elvira 1st floor master bed
room & laundry Beautiful lot \$182 900

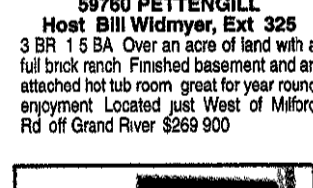

HAMBURG 1-4 PM
7857 HOWARD
Host Rick Beaudin, Ext 685
3+ bedrooms 2.5 baths Immediate
occupancy very clean Close to
US 23 and Elementary school
great sub! Hill like new Wonderful
yard and deck \$244 000

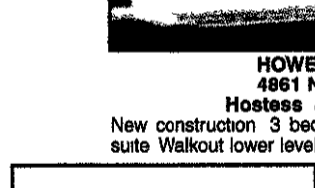

HAMBURG 1-4 PM
10410 BASSWOOD
Hostess Patty Furlington, Ext 300
4 bedrooms 2.5 baths Almost brand new
on beautiful lot! Sit at the end of private
drive with 4 acre common grounds Over
2000 sq ft with extra large rooms This
home has it all \$295 000



LINDEN 1-4 PM
6362 OAK LEAF TRAIL
Hostess Terri Shelley, Ext 330
Beautiful 1909 Colonial great neighbor
hood w/sidewalks & lights Neutral
decor 3 bedrooms 2.5 baths 3 car
garage Take Argentine N to Silver Lake
Rd E to River Oaks Hollow \$214 500

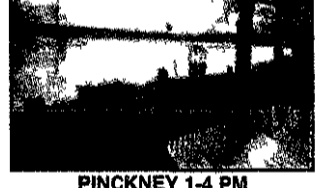

PINCKNEY 1-4 PM
5350 EDGELAKE
Host Kyle Hanchett, Ext 385
3 bedrooms 2.5 baths 2500 sq ft totally
redone ranch w/100 ft frontage on
Strawberry chain of lakes Stunning
view from every window Bring your
boat move in by summer \$549 900

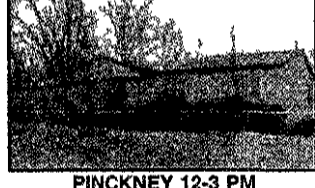

PINCKNEY 12-3 PM
2886 MACOMB ST
Hostess Joan Fletcher, Ext 312
1400 sq ft ranch with 1200 sq ft over
level 3 BR 2 BA C/A new windows & roof
first floor laundry fenced backyard 2.5 car
garage M 36 to Whitewood to Crystal to
Hill to Macomb MLS#22027790 \$186 500

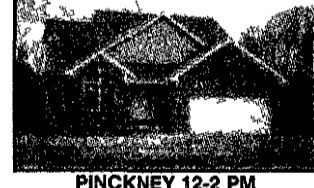

PINCKNEY 12-2 PM
831 SARAH
Hostess Dina Sabuda, Ext 251
3 BR 2.5 BA 1 acre features total seclusion
to rear of home overlooks vacant acreage &
wetlands 2 story nook & GR custom
upgrades h/ds everywhere 1st fr master
full w/bsmt hot price nr \$289 900

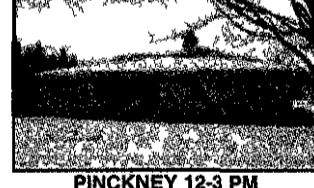

PINCKNEY 12-3 PM
3274 PATTERSON LAKE RD
Hostesses Lori Talbot &
Karen Wing, Ext 335 or 630
3 BR 2 BA 10 acres, Pinckney schools
Bring your horses Open floor plan 2 out
buildings M 36 to Dexter Pinckney Rd
S to Darwin Rd W to home \$269 900



HOWELL 1-4 PM
2420 WHITE BIRCH TRAIL
Host Ken Ives, Ext 235
4 BR 3 BA 10 Acre woods stream horse
barn pasture addl onal 4 car garage/leap
over/casestball of 3070 sq ft updated
Colonial S of Jewell Rd W of Cedar Lake
Rd Cell 610-444-4530 \$359 900



HOWELL 1-4 PM
526 W CRANE
Hostess Linda Barnwell, Ext 316
4 BR 1 BA Cozy charming Cape Cod
close to town Beautiful hardwood floors
coed ceilings and arched doorways
16x10 screened in porch Off Grand River
South on Jewett to Crane \$159 900



FOWLERVILLE 1-4 PM
11482 HEATHERWOOD TRAIL
Hostess Linda Schrader, Ext 370
3 BR 3 BA Must See this 2000 sq ft
Cape Cod on 3.8 country acres First
floor master suite first floor laundry
daylight basement Fowlerville Rd N to
Sober W to Heatherwood S \$225 000



BRIGHTON 1-4 PM
817 PINE EAGLES
Hostess Marcia Geise, Ext 246
3 BR 2.5 BA spacious Condo with
walk out basement Formal living & din
ing room doorwall to deck Take
Brighton Rd to Oak Pointe and turn
right 3rd st turn left \$267 500



BRIGHTON 2-5 PM
1375 BAYWOOD
Host Richard Butler, Ext 240
4 BR 2.5 BA Beautiful almost new brk
Colonial with 3 car att garage n great
neighborhood Take US 23 to Lee Rd
Exit West 2 miles to entrance of
Oakridge Sub Follow signs \$297 900



BRIGHTON 1-4 PM
6580 ACADEMY
Host Bob Waltz, (810) 844-2688
4 BR 1 BA Grand River East to Academy
South to house Ready to move in on All
Sports Island Lake Re-rode ed in s de and
out Prrv dock beautiful view home waranty
MLS #22014667 A Must See \$239 900

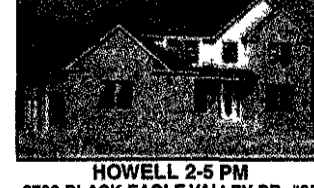

HOWELL 2-5 PM
2782 BLACK EAGLE VALLEY DR #35
Host Larry Buckmaster, Ext 271
Beautiful new construction features 4 BR
2.5 BA 3 car att gar + walk out bsmt
Cul & construction - 3500 sq ft thru out
Take D-19 to Coon Lk Rd West to County
Farm Rd N 36 to (on right) \$329 900

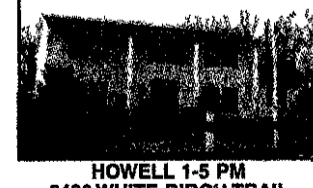

HOWELL 1-4 PM
BY APPOINTMENT ONLY
Host Nancy Hubbell, Ext 217
4 BR 2.5 BA New home ready for occupan
cy 1 acre with treed border FP cuth ceiling in
GR 1st fr master formal din/den bonus rm
daylight lower level plumbed for BA Mant
free exterior MLS #21077421 \$294 900



HARTLAND
BY APPOINTMENT ONLY
Host Rob Schroder, Ext 670
4 bedroom 3 bath Awesome Tr level
with volume ceiling & multi decks &
lots of space for the family ON THE
LAKE North of I 96 West of US 23
MLS #21094158 \$275 000

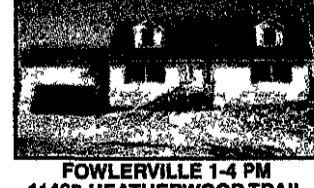

HOWELL
BY APPOINTMENT ONLY
Host Alex Sprankle, Ext 628
5 BR 2.5 BA Beautiful back ranch sets up
high on the hill on 3 acres. 40x70 cinder block out
building w/wood floor & driveway Lower level
has completely separate living quarters w/com
plete kitchen & BA MLS #21021869 \$279 900



HAMBURG 12-5 PM
8377 ALTA VISTA
Host Rob Schroder, Ext 670
4 BR 2.5 BA Beautiful Winan's Wood's com
munity Adjacent to nature preserve Spacious
rooms & quality updates galore golf & beach
privileges available You'll love this one N off
Chilwin E of Brighton Rd \$459 000

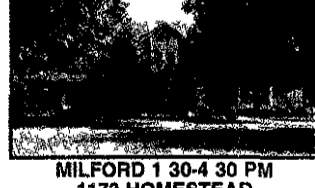

MILFORD 1-30-4-30 PM
1173 HOMESTEAD
Host Ron Laroche, Ext 257
3 BR 2.5 BA Great home nestled on 3 acres
with pond 1.5 story hardwood flrs formal
FR cole barn & many more amenities N of
196 on Milford Rd to Od Milford Farms
Homestead s off Milford Rd East \$379 900

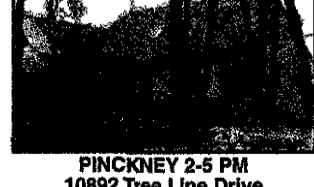

PINCKNEY 2-5 PM
10892 Tree Line Drive
Hostess Nancy Hubbell, Ext 217
Treed, 75 acre near schools Chain of Lakes
& rec areas. Skylights & vaulted ceilings FP in
GR 1st fr master wood windows & 2x6 const
CA deck M-36 to Whitewood & McGregor S
to Shehan to Tree Line Dr \$279 900



HARTLAND 1-4 PM
9265 FAUSSETT
Host Tim Sinclair, Ext 293
4 BR 2 BA Beautiful Cape Cod on
grooved 1 acre lot 3 car garage great
access to expressway access Clyde Rd Exit
US 23 Service Drive N to Faussett
West 1/2 mile to home \$244 900



HARTLAND
BY APPOINTMENT ONLY
Host John MacLeod, 810-884-2327
4 BR 2.5 BA New home ready for occupan
cy 1 acre with treed border FP cuth ceiling in
GR 1st fr master formal din/den bonus rm
daylight lower level plumbed for BA Mant
free exterior MLS #21077421 \$294 900



HOWELL
BY APPOINTMENT ONLY
Host Linda Barnwell, Ext 316
2 BR 2 BA Nicely maintained mobile home w/en
vironmentally located in Brighton Fenced backyard new win
dows & roof Perfect starter ready to move in! North
on Hacker from Grand River to Twin Beach West on Twin
Beach to SkyView MLS #2231799 \$84 900



BRIGHTON
BY APPOINTMENT ONLY
Host Gail Levy, Ext 261
3 BR 2 BA Fabulous new Ranch in Woodland
Springs! 3 car gar daylight windows in bsmt. cust
om paint, deck landscaping & sprinklers already
done many upgrades on large lot & much much
more Call for Appt MLS #21100189 \$290 500



SOUTH LYON
BY APPOINTMENT ONLY
Host John MacLeod, 810-884-2327
3 bedrooms 2 baths 2.5 acres
splittable Beautiful lot with lots of
trees Close to downtown Howell
and expressways Howell Schools
MLS #21058677 \$219 000



FOWLERVILLE
BY APPOINTMENT ONLY
Host Lori Talbot & Karen Wing Ext 336 630
4 BR 1.5 BA Beautiful well ma nta red
Colonial in downtown Fowlerville Updates
include new furnace & carpet. Walk to schools
shopping churches & post off ce 2400 sq ft
under \$200 00 MLS #21100541 \$199 500



HOWELL
BY APPOINTMENT ONLY
Host John MacLeod, 810-884-2327
New construction Cape Cod Only 13
home subdivision 1/2 to 3/4 acre lots
City sewer & water all paved roads only
12 miles to I 96 on off ramp Howell
Schools MLS #22007465 \$269 900



BRIGHTON
BY APPOINTMENT ONLY
Host Nancy Hubbell, Ext 217
4-5 BR 3-2 BA Sparkling 1+ acre spring fed pond
wraps around this newer 1.5 story 1st fr master
2 FPs fam m/library loft oak flrs, Hickory cab netry full
fr w/o spa. CA, on 10 gorgeous acres Near state
land Great for horses MLS #22034917 \$514 900



SOUTH LYON
BY APPOINTMENT ONLY
Host John MacLeod, 810-884-2327
4 BR 3 BA Mini Estate 4.5 acres
with 2 pole barns pond and large
in ground pool Ideal for small busi
ness Horses allowed Truly one of
a kind MLS #27071985 \$665 000



HOWELL
BY APPOINTMENT ONLY
Host Linda Barnwell, Ext 316
2 BR 2 BA Nicely maintained mobile home w/en
vironmentally located in Brighton Fenced backyard new win
dows & roof Perfect starter ready to move in! North
on Hacker from Grand River to Twin Beach West on Twin
Beach to SkyView MLS #2231799 \$84 900



BRIGHTON
BY APPOINTMENT ONLY
Host Gail Levy, Ext 261
3 BR 2 BA Fabulous new Ranch in Woodland
Springs! 3 car gar daylight windows in bsmt. cust
om paint, deck landscaping & sprinklers

COLDWELL BANKER SCHWEITZER REAL ESTATE

Congratulations to these Agents for their Outstanding Performance for 2001!



John Goodman
#1 in Northville Office
Circle of Excellence
International President's Premier
Founders Award
Top 30 Club

Northville Office
Tricha Kneiding, Manager/Associate Broker

 Michele Stafford Circle of Honor Internat'l President's Premier Founders Award Top 30 Club	 Jim Wolfe President's Elite Circle of Honor Founders Award Top 30 Club	 Marionne Prokop President's Elite Founders Award Top 30 Club	 Ann Shahn President's Circle Circle of Honor Top 30 Club	 Jeff Kautler President's Circle Top 30 Club	 Fred Kapadia President's Circle Top 30 Club
 B.J. Pruitgan Circle of Honor	 Deborah Horner Top Honors	 Melody Arndt Top Honors	 Nadine Fab Top Honors	 Nancy Downey Top Honors	 Kim White Top Honors

Also recognized for Top Sales Achievement:
Barbara Buckthorpe Richard Childs Jann Forster Ruth Genso Charles Jackson
Paula Kennedy Helena Lee Laura Monley Charles Smart Cathy Sloan



Chris Knight
#1 Agent Company Wide
International President's Premier
Circle of Excellence
Founders Award
Top 30 Club

Plymouth Office
Neal Lanphear, Manager/Associate Broker
Lynn Vaneman, Sales Manager/Associate Broker

 Nancy Patmell Assistant Manager Circle of Honor Top 30 Club	 Bob Bate Associate Broker	 Kim Boly GRI Award Winner	 Jan Dibble Assistant Manager Associate Broker	 Mike Gatter Award Winner	 Janet Schwartz Top Producer
 Joyce DeWahlert Assistant Manager Top Producer	 Dore Zanker Top Producer	 Bill Decker Associate Broker	 Chris Dillon Top Producer	 Gordon Mc Cann Top Producer	 Liz Schneider CCPS CRS

Also recognized for Top Sales Achievement: Debbie Ley Tracy Brovage Kelly Ireland

 PLYMOUTH \$529,900 Hurry over to this incredibly priced 4BR brick colonial located on an exec size lot in much desired Country Club Village. Features incl lux mas ste w/wash bath gour kit & nook w/hdwd frs Hurry! (BGP 60Fel) 888 223 6691	 BELLEVILLE \$158,500 Cute! Cute! Lake Cottage! This 1 bdrm Lake Cottage has many possibilities. This home sits on a full 200ft deep lot & on a dead end st. Put your boat in its own pvt slip. Enjoy 3-Season rm & deck. (BGN95ALV) 888-220 3751	 GARDEN CITY \$149,900 Garden City Trn level with built in pool 3 BD 1 1/2 bath 2 car garage. Newer tile & windows with blinds thru out. All appliances stay. Nice area & close to expressways & airport. (BGP 41Don) 888 223 6691	 LIVONIA \$324,900 Hot Golf Course Property! W/4br & 2 1/2 baths 2300 sq ft formal dr 1st floor laundry updated kitchen ceramic & oak foyer Huge mbr suite Jet tub in bath Patio view to golf course. (BGN49OAK) 888 220 3751	 LIVONIA \$229,900 Large Sprawling Ranch on a Huge Gorgeous Lot! 29x17 Great room wonderful for gatherings Formal living & dining 4bd 2 1/2 baths 2 car attached garage & more Hurry! (BGN65NEW) 888-220-3751	 PLYMOUTH \$204,900 The good life begins at home in this 3 BR 1 1/2 BA brick ranch on a fenced wooded 1/3 acre lot. Large sunny rooms fireplace 2+ car garage with workshop and much more. (BGP 75Gov) 888 223-6691	 SOUTH LYON \$244,900 Priv Beach & Boat Ramp to all sports chain of lakes Great 1+ acre brick ranch w/wood view Skylight in kitchen cath ceil in LR hdwd frs in kit Din area & LR newer roof 97 & furn 01 BGL60CRO 877 206 6853
 PLYMOUTH \$519,900 Magnificent 4 bedrm 3 bath home on premium lot Gourmet kitchen lavish master & 2nd bedrm with bonus rm Custom paint & wood trim throughout Daylight basement cedar deck & 3 car garage Sub has pool (BGP 20Hil) 888 223-6691	 CANTON \$249,900 Better than new condo overlooking pond. Open floor plan w/numerous upgrades. Large master suite w/sepa rate shower and jacuzzi tub. Garden windows in basement. (BGP 01Hog) 888 223 6691	 HOWELL \$279,900 Warm & inviting! A wonderful 4 br 3 1/2 bath colonial with finished walkout basement overlooking pond and commons area. Many upgrades and features enhance the beauty of this fine home. (BGL43SNO) 877 206 6853	 LIVONIA \$324,900 Condo Living at its Finest! First floor master suite w/glamour bath 2 story great room w/fireplace 3 br 2 1/2 baths library dining room loft upstairs finished lower level. (BGN23VIS) 888-220 3751	 Northville \$342,900 Luxury Ranch end unit Golf course steps away Elegant neutral decor w/decorative touches Beautifully appointed maple kitchen w/ceramic tile 2 bdrm 2 bath beauty surrounded by evergreens. (BGP-85Loc) 888 223 6691	 REDFORD \$147,900 Surprising buy in south redford 3 br ranch in pristine condition. Newly updated kit all new appl newly fin hardwood floors some newer wind ows new roof shingles fin basement home warranty. (bgl87kin) 877 206 6853	 SOUTHFIELD \$119,900 Investment Opportunity This neat 2 BR 1 Bath Bungalow w/fireplace & 2 car garage offers first time buyer possibilities. Great Southfield location on 1.28 acres. A must see. (BGL-43DUN) 877 206 6853
 BELLEVILLE \$169,900 Here it is! Great home w/Great Location! On 1 acre of land 3 br 1 bath home has lots of updates remodeled kitchen w/oak cabinets & marble look counter tops & bar. All appl stay incl washer & dryer. (BGN70TYL) 888 220 3751	 DEARBORN \$250,000 Victorian colonial will suit your needs! 4 br 2 baths with a finished basement possible 5th br or office Mrs clean lives here. Call fast! big15col 877 206 6853	 LIVONIA \$389,900 Big Family? Read On! 6 br 4 full baths 2 kitchens finished basement almost 1 acre w/deer many updates furnace AC roof windows 2 hwh Need rooms Two year home warranty. (BGN45MAY) 888 220 3751	 LIVONIA \$239,900 A Touch of Greenfield Village describes this 4 BR 1 1/2 bath colonial LR w/cove ceilings HWF & fireplace Updated kitchen w/oak cabs Family rm Vinyl windows 2 car garage BGL05WCH 877 206 6853	 PLYMOUTH \$394,900 This stately almost new colonial has been impeccably kept and is decorated in neutrals. Nine ft ceilings large spacious rooms and all the amenities. 888 220 3751	 REDFORD \$117,900 Super 3 BR 2 full bath Ranch Lots of privacy on a dead end street Freshly painted & remodeled main Bath. Must See Country living in the city. BGL80SAN 877 206 6853	 WESTLAND \$154,900 Very Sweet Newer Home! Has huge master br w/full wall of closets. Updates include most windows Berber carpet in lr glass block windows hwh. All this plus 2 1/2 car garage & deck. (BGN98DEE) 888 220 3751



For more properties visit our website at:



www.cbschweitzer.com

Phone In, Move In...

- ☐ A same-day mortgage decision or we'll pay you \$250*
- ☐ To meet your requested closing date or we'll reduce your interest rate by 1/8th of one percent for the life of the loan
- ☐ To beat any lender's price, GUARANTEED, or pay you \$250**

1-888-317-2530

L1102827

Livonia Office – 734-591-0333 • Northville Office – 248-347-3050 • Plymouth – 734-453-6800

Ann Arbor • Birmingham • Clarkston • Bloomfield Hills • Farmington Hills/W. Bloomfield • Grosse Pointe Hill • Grosse Pointe Woods • Lakes Livonia • The Macomb Center • Northville • Plymouth • South Lyon • Troy

REAL ESTATE BRIEFS

Real estate briefs features news and notes on professional associations, office activities, upcoming meetings and seminars, new services/products and consumer publications

Write Real estate briefs, Observer & Eccentric Newspapers, 36251 Schoolcraft, Livonia, 48150 Our fax number is (734) 591 7279 Our e mail address is dfunke@oe homecomm net

CAREER CLASS

Keller Williams Realty, Livonia, hosts a free class on how to get into real estate sales 10 a m Friday, April 26, at its office, 31500 Schoolcraft To register, call (734) 266-9000

BUY HOME FAIR

The Michigan Mortgage Lenders Association sponsors a free Homebuyer Education Event 9 a m to 2 p m Saturday, April 27, at the University of Detroit Mercy Calihan Hall, McNichols at Livernois, Detroit Workshops, scheduled for 9 30 a m, 11 a m and 12 30 p m, will focus on ownership overview, repairing credit, financing, and saving for a down payment For more information, contact MMLA at (248) 356-6857

BUILD HOME CLASS

Oakland Home Builders and Bloomfield Hills Community Education offer a comprehensive 16-hour class, "How to Build Your Own Home," 6-10 p m Tuesdays and Thursdays, April 30-May 9, at Andover High School Topics include estimating costs, building codes/permits and construction basics Cost is \$175 plus \$25 for two textbooks To register, call (248) 433-0885

PROPERTY INVESTORS

The Real Estate Investors Association of Wayne County presents a program on making money in subsidized housing 7 30 p m Tuesday, May 7, at the Holiday Inn Heritage Center, 17201 Northline, east of I-75, Southgate Cost for non-members is \$20, which can be applied to an annual membership For more information or a free newsletter, call (313) 386-7228

BASEMENT REMODELING

Oakland Builders Institute and Livonia Community Education offer an eight-hour basement remodeling class 6-10 p m Tuesday and Thursday, May 7

and 9, at Riley Middle School, 15555 Henry Ruff, Livonia Topics include planning, building codes, estimating materials and construction basics Cost is \$95, plus an \$8 textbook fee To register, call (734) 523-9277

SELL HOME CLASS

Alma Mathley, affiliated with Professional Real Estate Appraisal and Title, and Citizens Mortgage Funding sponsor a free seminar, "For Sale by Owner," 7-8 30 p m Wednesday, May 8, at Hunter Community Center, 509 Fisher Court, off Main two blocks north of 14 Mile Road, Clawson To register, call Mathley at (248) 851-2975

BUY HOME CLASS

Juliette Bauman, a Realtor with RE/MAX Classic in Livonia, and Colonial Mortgage present a free class for home buyers 6 30-9 p m Thursday, May 16, at the Livonia Civic Center Library, 32777 Five Mile Road, east of Farmington Road, Livonia To register, call Bauman at (734) 779-9977

DEVELOPMENT STATUS

CoreNet Global Michigan

Chapter presents a panel discussion on the current state of development in the state noon Thursday, May 16, at Glen Oaks Country Club, 30500 W 13 Mile Road, Farmington Hills Cost, which includes lunch, is \$35 for members, \$50 for non-members For information, contact Casey Clugston at (248) 399-0700 Ext 428

FAIR HOUSING AWARDS

The Fair Housing Center of Metropolitan Detroit is looking for nominees for its annual leadership awards People or firms employed or doing business in the housing industry - sales, rentals, condos, lending, insuring, appraising - are eligible Nominating forms, available from the Fair Housing Center at (313) 963-1274, are due June 1

CAREER CLASS II

Real Estate One presents a free class on how to get into residential real estate sales noon to 1 15 p m every Wednesday through June at its Farmington Hills office, 32961 Middlebelt at 14 Mile Road To register, call Steve Leibhan at (248) 851-4100 Ext 405

HABITAT FOR HUMANITY

The western Wayne affiliate of Habitat for Humanity seeks volunteers to help with building homes, office duties and fundraising No experience needed Training will be provided For details, call (734) 459-7744

ENERGY CD-ROM

The Building Owners and Managers International has released a CD ROM, "The Property Professional's Guide to Building Energy Performance" Cost is \$15 for BOMA members, \$25 for nonmembers To purchase or obtain more information, call (800) 426-6292, or visit the Web at www.boma.org/pubs/energy_cd htm

BIA UPDATES

The Building Industry Association of Southeastern Michigan now provides weekly updates of news and information affecting the construction industry to members via e-mail Contact Rosalie Lamb at the association, (248) 737-4477 for details

CONTAMINATION SITES

VISTAinfo, a publicly owned company based in San Diego, has a Web site that offers a free

overview of environmental conditions - contaminated waste sites, hazardous waste locations and landfills - by ZIP code

The Internet address is www.NearMyHome.com More specific reports are available for a fee

PLAYGROUND SAFETY

A book available from the Community Associations Institute can help community association managers and board members ensure that their playgrounds and tot lots are as safe as possible

Detailed information is provided on safety inspections and implementing an effective maintenance plan

"Playgrounds for Young Children" is available for \$40 by calling (703) 548-8600, or ordering through www.caonline.org

SALES WEB SITE

Curious as to what houses are selling for in your neighborhood? Steve Wiese of Southeastern Appraisal Corp in Farmington Hills has updated maps on a community-by-community basis with that information on the Internet And it's free Just dial up www.homeval-uemap.com

FOR SALE BY OWNER? FREE SEMINAR TO HELP YOU SELL!

- Is your price realistic?
- Are you advertising effectively?
- How will you handle the title side of the transaction?
- Are you prepared to negotiate the sale?



Tuesday, April 30th 7:30-8:30pm
Summit on the Park
46000 Summit Parkway,
Canton

For Reservations call 734-455-2219 (Cortney)



Inventory, organize cluttered garage

(HIT) - It's easy to make the garage a room for all those things we don't really have a place for That goes for a new home, as well as existing "We tend to use the garage as a catch-all for many of the items we need, but don't know what to do with," says Marc Shuman,

founder of GarageTek, a company that specializes in organizing garages

The company's products include cabinets, shelving, activity racks and accessories Clients run the gamut from down-sized tech executives to developers who incorporate high-tech garage systems into the homes they build

Shuman says the garage is the most "abused" room in the house and can easily be turned into a high-value asset

Use an organizing opportunity to take inventory of items you will need for spring such as musing garden tools

To get the process of spring cleaning in the garage going, Shuman recommends the following

- Arrange items you want to keep in piles
- Determine what kinds of containers will best store these items
- Hang pegs to organize certain items

Even lawn chairs can be stored on long pegs

■ Bicycles can be hung from the rafters when not in use When bicycles are in season, assign a certain place for them to be parked

■ Keep as many items off the garage floor as possible so it's easy to sweep often Twice a month is a good schedule Remember that dust from the garage often ends up in the house

■ If you have bare studs in the garage, place slats of wood across the studs to create bins for items like sports equipment and gardening tools

■ Hammer nails into the wall or into the studs for tools and other articles

■ Keep similar items together in marked containers and go through them once a season to clean things out you're not using any more

APPROVED MORTGAGES, INC.

RATE/APR	
30 Year Fixed	15 Year Fixed
6.75 / 6.92	6.25 / 6.39

Note: Rates and APR based on 30 day rate lock for loans \$150,000 to \$300,700. Rates may change on a daily basis. Please call for up to the minute pricing.

Call Today: **734.455.5584**

COLDWELL BANKER PREFERRED REALTORS®

<p>CONTEMPORARY FLAIR - Four bedroom 2 1/2 bath colonial updated large kitchen wall upgraded appliances Full finished basement storage galore spiral staircase in ceramic foyer 1st floor den and laundry New roof 2 car attached garage and park like lot \$274 900 (655BA)</p>	<p>WATERFRONT - Waterfront ranch style home 4 bedrooms 2 baths 2 kitchens master bedroom sewing room Nice floor plan for mother in law area 2 car attached garage plus a detached 1+ car storage facility w/covered picnic area Double walkway boat dock facility w/access to Edison/Belleville Lake waters Lakeside viewing room \$309 900 (805HC)</p>	<p>BEAUTIFUL LUXURY CONDO - Better than new luxury condo Three bedrooms 2 1/2 baths master w/Jacuzzi tub Beautifully decorated neutral ready for you to move in Great room den finished walkout 2 car garage hardwood floors Great Dearborn location \$245 000 (766MA)</p>	<p>DESIRABLE NOVI SUB - This 4 bedroom 2 1/2 bath cape cod is nestled within sub on a lovely landscaped yard with beautiful pine trees Supersized deck bright spacious and airy rooms den 1st floor laundry etc \$339 900 (744SU)</p>	<p>SUPER SHARP DETROIT COLONIAL - This stately all brick colonial features 3 large bedrooms a huge living room w/natural fireplace beautifully decorated formal dining room kitchen w/breakfast area a cozy family room & library newer roof (tear off) new carpeting flooring and wallpaper throughout Must see \$149 500 (198SA)</p>	<p>GREAT BEGINNINGS - Lots of news in this one Vinyl windows never furnace plus a fresh coat of paint make this 3 bedroom ranch w/basement garage and hardwood floors a winner! Quick occupancy \$112 000 (161KI)</p>	<p>1856 FARMHOUSE IN SALEM TWP. - If you're looking for the peace & quiet of country living but want to be close to conveniences this is the home for you! Lots of original amenities in this beautiful & updated home Mechanics dream 4 car detached garage with workshop & heat plus a 2 car shed Wonderful 1.35 park-like acres \$284 900 (809SA)</p>
<p>BEAUTIFUL BI-LEVEL - Spacious home on great lot! Open floor plan w/large kitchen Finished lower level includes family room office and lavatory Central air and deck Appliances included \$209 900 (797BE)</p>	<p>TOTALLY REMODELED HOME - Newer kitchen newer bath newer furnace carpet paint windows updated electric beautiful sunroom and more! Hurry it won't last! \$182 900 (837KI)</p>	<p>TAKE A LOOK - This well kept brick ranch has an open floor plan 3 bedrooms and a large lot A beautiful bay window in living room newer windows hardwood floors ceramic tiled bath C/A copper plumbing are just a few of the features \$151 900 (301QA)</p>	<p>NORTHVILLE HILLS - Oakton colonial at Northville Hills boasts 4 bedrooms 2 1/2 baths and all the good stuff - Corian granite hardwood maple cabinetry premium trim package loft overlook opulent master bath and a setting backing to the 18th fairway \$562 500 (413BA)</p>	<p>EXTRA SHARP RANCH - Beautiful clean ranch home just minutes from downtown Belleville and major freeways move in condition The well kept home you've been searching for w/well designed convenient kitchen 3 spacious bedrooms partially fin bsmt already set up for rec room & extra bedroom and 2 car attached garage \$195 000 (589TH)</p>	<p>IMAGINE THIS - Looking for 5 bedrooms and 2 baths? Check out this affordable Livonia 2 story with updates inside and out \$167 500 (185RI)</p>	<p>GREAT LOCATION - Hurry on this spacious and totally renovated 2 bedroom Canton condo featuring newer windows with door/wall to balcony carpet C/A kitchen w/pantry all appliances freshly painted (2001) and carport One year home, protection plan \$112 900 (411SA)</p>
<p>CUTE AND COZY - Well maintained 3 bedroom bungalow in Livonia Updates include roof windows and central air Also has a Florida room and deck Affordable for first time buyers \$129 900 (614FL)</p>	<p>CANTON COLONIAL - Nice home - 3 bedrooms 2 1/2 baths (with master bath) newer carpet 1st floor laundry kitchen floor sink & faucet and a family room w/fireplace Enjoy your yard in your gazebo! \$229 900 (150KN)</p>	<p>FARMINGTON HILLS CHARMER - Fantastic colonial in great family neighborhood Master suite on entry level 2 full baths extra large corner lot living dining and family room large kitchen and too many updates make this home a must have Two and one half car garage and mature landscaping are additional bonuses to this great opportunity \$224,900 (853QU)</p>	<p>WONDERFUL LIVING SPACE - Beautiful colonial in popular Plymouth Twp Decorated to perfection T/O professionally landscaped w/large brick paver patio This home has all the amenities a spacious family room country size kitchen formal living & dining and huge master bedroom for your own private retreat \$399 900 (883QU)</p>	<p>PRIDE OF OWNERSHIP - Updated 2 bedroom condo all appliances stay! Neutral décor Updates include wood floors and track lighting in kitchen retiled bath with pedestal sink 1 car detached garage Satellite dish stays Finished basement \$159 999 (178CO)</p>	<p>ENJOY A DAY OF BOATING ON... Perfect location for sunrise views overlooking Runyan Lake This is a great investment on private all sports Runyan Lake Dock raft and boat facilities are available No other property on Runyan Lake with this much to offer \$249 900 (526RU)</p>	<p>NORTH CANTON COLONIAL - Spacious almost 2 400 sq ft 4 bedrooms 2 full and 2 half baths Formal dining room 1st floor den and laundry Spacious kitchen and nook Finished basement Nicely basement \$305 000 (717WH)</p>

All Real Estate Companies are not the same DISCOVER THE DIFFERENCE

Visit us on our Web Site... www.cbpreferred.com

MORTGAGE FINANCING
What getting a mortgage should be.
We'll beat any lender's price, or pay you \$250*
Guaranteed loan decision the same day you apply or we pay you \$250

1-888-895-2536 Toll Free

COLDWELL BANKER MORTGAGE

NORTHVILLE/NOVI (248) 305-6090	CANTON (734) 392-6000	FARMINGTON (248) 478-6022	WESTLAND/GARDEN CITY (734) 392-6000	PLYMOUTH (734) 459-6000	LIVONIA (734) 425-6060
--	---------------------------------	-------------------------------------	---	-----------------------------------	----------------------------------

Observer & Eccentric

CLASSIFIEDS

Our Ads Are ON-LINE at:

www.observerandeccentric.com

1.800.579.SELL

LOOK What Happens When You Advertise In Our CLASSIFIEDS... JANITORIAL HELP Needed Evenings, Livonia area. Excellent Pay. Response to the ad was very good J, Howell

OUR LINER DEADLINES SERVE YOU BETTER! Publication Day Deadline SUNDAY PAPER 5:00pm Friday THURSDAY PAPER 5:30pm Tuesday OBSERVER & ECCENTRIC CLASSIFIEDS WORK!

All Ads Run Online FREE! A Value Of Up To \$87 00 Place Your Ad Toll Free 1.800.579.SELL • E-Mail Ads: oeads@observerandeccentric.com • Fax: 734-953-2232

Home & Service Guide #001-245

Real Estate For Sale #300-389

Commercial Industrial Sale or Lease #389-398

Real Estate For Rent #400-498

HELP WANTED Employment/ Instruction Services #500-598

Announcements #600-698

Merchandise #700-778

Garage Sale Moving Sale #711-713

Animals Pets/ Livestock #780-798

Automotive Recreational Vehicles #800-899

Walk-In Office Hours: Monday - Friday 8 30 am - 5 00 pm. OBSERVER SALES OFFICE 36251 Schoolcraft, Livonia, MI 48150. ECCENTRIC SALES OFFICE 805 East Maple, Birmingham, MI 48009. DEADLINES: Place, Cancel or Correct Liner Ads. Publication Day Deadline SUNDAY REAL ESTATE 5:00 P.M. FRIDAY SUNDAY PAPER 5:00 P.M. FRIDAY THURSDAY PAPER 5:30 P.M. TUESDAY

Observer & Eccentric

REAL ESTATE

All Ads Run Online FREE! A Value Of Up To \$87 00

www.observerandeccentric.com

300's Real Estate

- 303 Open Houses 304 Ann Arbor 305 Birmingham/Bloomfield 306 Brighton 307 Canton 308 Clarkston 311 Dearborn/Dearborn Hgts 312 Detroit 314 Farmington/ Farmington Hills 317 Garden City 318 Grosse Pointe 319 Hamburg 320 Hartland 321 Highland 322 Holly/Fenton 323 Howell 325 Livonia 326 Milford 327 New Hudson 328 Northville 329 Novi 331 Onon Township/ Lake Onon/Oxford 333 Pinckney 334 Plymouth 335 Redford 336 Rochester/Auburn Hills 337 Royal Oak/Oak Park/ Huntington Woods 338 Salem/Salem Township 339 Southfield/Lathrup 340 Troy 342 Waterford/Union Lake/ White Lake

390-398 Commercial/ Industrial

- 390 Business Opportunities 391 Business & Professional Buildings For Sale 392 Commercial/Retail Sale Or Lease 393 Income Property 394 Industrial Sale Or Lease 395 Office Business Space Sale Or Lease 396 Commercial/Industrial Vacant Property 397 Investment Property 398 Land

303 Open Houses

BEVERLY HILLS Open Sat & Sun 14 16950 Elizabeth N of 13 Mile W of Piacere 1427 sq ft ranch 3 bedroom 1.5 bath A must see large family room & deck at back Asking \$232 000 By Owner (248) 647 6114 BLOOMFIELD OPEN SUN 1-4pm 1230 Square Lake Road S side of Square Lake Rd E of Squirrel Wonderful ranch on 1+ acre lot in Bloomfield 3 bedrooms 1 1/2 baths 2 car attached garage Charming \$269 900 Cranbrook Associates Inc 248 647 0100 BLOOMFIELD VILLAGE OPEN SUNDAY 2-4pm Lovely 4 bedroom 2 1/2 bath colonial on an extra large lot. Completely updated with charm and style! DiGiulio Kitchen New hardwood floors Plan to see 120 N Williamsbury (N of Maple W of Cranbrook) \$569 900 (WIL1120) HANNETT-WILSON & WHITEHOUSE (248) 646-6200 CANTON OPEN SAT & SUN 1 6pm 2656 Woodmont East, Palmer/ Sheldon '92 built, 1600 sq ft 3 bedroom \$235 900 (734) 367-3004

303 Open Houses

CANTON By owner Open Sat Sun Noon 6 or call for personal appt. Beautiful Cape Cod built in 1998 in popular Pheasant Woods sub 41764 Princess Dr (between Cherry Hill & Palmer off Lilley) (734) 394 1636 **CANTON GEM** Open Sunday 2 5 39724 Fox Valley (S/Cherry Hill E/Haggerty) Beautiful 3 bedroom 2.5 bath brick ranch with wet bar. Too many features/updates to list MUST SEE! Home warranty offered Visit www.richmondworld.com or call (734) 397 3895 Asking only \$199 900 Canton Open Sun 1 4 47600 Royal Pointe Dr S Warren W Beck Royal Pointe Sub Move in condition 4 bedroom 2 full + 2 half baths finished basement 4 gas fireplaces Backs to com morns \$415 000 Harvey Ruben Far Realty 734 416 3369 DETROIT Open Sun 1 4pm 7345 Rockdale Copper Canyon 3 bedroom updated bungalow garage & basement \$359 900 Agent Owner (734) 306 9027 FARMINGTON HILLS Open Sun 1 4 Brick colonial 4 bed room 2.5 bath large lot gated community 3142 Applewood Ln \$430 000 248 681 6851 FARMINGTON HILLS OPEN SAT & SUN 2 5 Immaculate updated maintenance free colonial. Newer kitchen baths roof windows furnace & C/A 3 bedrooms 1 full & 1 half bath w/ semi finished basement Sought after Farmington Green Sub 28166 Yorktown N 12 Mile btwn Drake & Farmington Rds Great Value at \$239 500 248 553-4405 FARMINGTON OPEN SUN 1 4 32630 Meadowlark N/8 Mile E Farmington Gorgeous home only \$234 900 OPEN SUN 1 4 Quaker Valley Farms 33750 Braebury N 11 Mile W Farmington Spacious ranch only \$419 900 CALL ANNA (734) 452 1176 KELLER WILLIAMS REALTY GARDEN CITY Open Sat 27th 10 30pm 8579 Hawthorne Merriman and Warren area 3 bedroom brick ranch finished basement w/ fireplace Other updates \$152 900 LIVONIA OPEN SAT & SUN 12-4pm Charming cape Cod Great starter home 27431 Long Near Grand River & Inkster Livonia OPEN SUN APRIL 28 1 3 9780 Wayne Rd Newer 3 bedroom 2.5 bath home Kitchen w/ceramic tile family room master suite w/bath huge back yard has hot tub & deck Circular deck paver entry \$239 900 East side of Wayne between Plymouth & Ann Arbor Trail #23022 Jason Aros Boggs 734 665 0300 eves 734-663 5025 Charles Reinhart Co Realtors LIVONIA Open Sun 1 5 19622 Auburndale 3 Bedroom brick ranch 1.5 bath finished basement entirely updated A Must see! \$179 900 248 615 0636 NOVI SUN 4-28 12 4pm 10 & Beck 47645 Wellesley Court GREENWOOD OAKS Cape Cod 4750 sq ft (Includes profationally finished walk out basement) on private wooded cul de sac lot Neutral decor hardwood floors extensive landscaping 2 story deck MUCH MORE TO SEE! \$569 900 (248) 374-5668

303 Open Houses

OPEN THURS 4-7 DOWNTOWN PLYMOUTH 590 Blunk Street Come to see the home stay for dinner! Hot dogs & chips The age of innocence built in 1950 when ones life centered on home and family This 3 bedroom reflects that uncomplicated time! Full upstairs master suite full finished basement 2 full baths Upgrades galore Listed at only \$254 900 hurry at this price it won't last long! To preview age! POBIN FINCAIN (734)797-0788 Real Estate One... 217 W Ann Arbor Rd Plymouth PLYMOUTH TWP DETACHED CONDO OPEN SUN 40722 Breckenridge S of 5 Mile/ W of Haggerty 1995 3 bedroom 3 1/2 bath cape cod w/ 1st floor master suite and 1st floor laundry Professionally finished walk out basement \$359 900 Agent Owner (734) 564-6457 (313) 680-3525 PLYMOUTH 2800 sq ft 4 bed room 2 1/2 bath colonial. Hard wood floors newly finished basement walking distance to downtown Byrd elementary & W Middle School \$319 900 Open Sun 1 4 11817 Wildwing W of Canton Center S of Ann Arbor Tr (734) 454 0864 ROYAL OAK 1529 North Atlanta South of 12 Mile South of teh Red Run golf course 3 bed room cape cod new windows carpet plant electrical large lot room to expand 2 car garage \$185 000 Open Sun 9 (248) 543-2216 and (248) 652-0336 SEARCH 1000's of Real Estate property listings at www.HomeTownLife.com Part of the Observer and Eccentric classified network SOUTHFIELD Ranch nestled on 1.5 acres wooded lot on golf course bay window overlooks private pond 2 natural fireplaces By owner must see! \$178 500 Open Sat/Sun 1-4 22215 Carleton S/9 Mi E/Beach 248-642-3148 TROY WEST Open Sun 1 6 By owner Cul de sac Troy schools 4 bedroom 2 1/2 bath colonial Built 1987 just remodeled move-in condition \$319 900 958 Keaton Dr 313-319 3646 248-616-9889 TROY 1627 Heatherwood Open Sun 12 30pm Wooded lot Master bedroom suite on 1st powder room 2 car garage full bath on 2nd 2 story great room dining room den kitchen/hook 1st floor laundry room Wood flooring crown molding fire place Attached garage cedar deck Last week before listing \$469 000 (248) 641 0799 W BLOOMFIELD Open Sun 12 5pm 6386 Aspen Ridge On 15/ Orchard Lake Rd Luxury contemporary condo 3 bedroom 2 1/2 bath approx 1800 sq ft former model unit end unit tons of upgrades A Must See! \$269 000/OBO (248) 626 5794 WHITE LAKE TWP CHARMING lakefront home on all sports Mandon Lake \$269 000 Open Sat/Sun 2 5 248 363 5527

305 Birmingham/ Bloomfield

BINGHAM FARMS 2100sqft 4 bedroom 2 1/2 bath ranch on 3/4 Acre treed lot w pool quiet cul de sac \$419 000 248 646-4905 Birmingham Builders Closeout Below Cost 2 600 sq ft 4 bedroom 3.5 bath luxury home located within walking distance to downtown Birmingham Beautiful gourmet kitchen with granite countertops Wood flooring throughout main level. Exquisite master suite with luxury bath 3 car garage with large fenced in yard Built 2001 \$609 000 Call Robbie 248 910 5121 BIRMINGHAM BUNGALOW Three bedroom 2 bath bungalow with many updates throughout Hardwood floors new master bath finished basement with Bar New roof and paver patio \$289 000 (SOU291) HANNETT-WILSON & WHITEHOUSE (248) 646-6200 BIRMINGHAM New Construction 2700sqft 4 bedroom 4 bath finished basement hard wood floors Fabulous master w/ bath & walk in closet \$679 000 By appt only (248) 642 8590 BLOOMFIELD HILLS Charming home 1 1/2 acres w/ perennial gardens 2800+ sq ft 4-5 bed rooms 3 full baths tumbled marble Hardwood floors white kitchen w/country hearth tile exposed brick oak beams two car garage walk to Cedar Mill \$419 900 motivated! 6659 Vachon Ct Franklin/Maple Agents protected (248) 851-5490 BLOOMFIELD HILLS \$249,900 Priced to sell! Almost 2400 sq ft 4 bedroom 2.5 bath Colonial w/partially finished basement C/A & fireplaces in both living room & family room Updated kitchen formal dining room & 2 car attached garage (WH688) BLOOMFIELD \$199,900 Diamond on the rough! Sprawling 3 bedroom 1.5 bath Ranch on 1.81 acre offers wet plaster construction covered ceilings exposed hardwood floors & full basement 3 fireplaces & 2 car side entry garage (WH170) BLOOMFIELD VILLAGE Beautiful home located on cul de sac in prestigious neighborhood Brick paved driveway walkways and patio Profession ally landscaped private back yard Everything has been done ready to move into Four bedrooms plus 5th room and bath in lower level Hardwood floors throughout Newer kitchen w/granite counters hardwood floor recessed lites opens to family room w/cathedral ceiling fireplace French doors to planter Wonderful flooring floor plan Newer furnace central air hot water heater etc Side entry garage \$754 900 Ask for RUTH SHOEMATE (248) 855 8546 CENTURY 21 M/JL CORP TRANS SERVICE

305 Birmingham/ Bloomfield

FRANKLIN RANCH 4 Bed room 2 bath 1 acre Walk to cider mill Seller financing \$347 000/best (248) 417 1265 Brighton ALL SPORTS Lake Outs de Front Door Triple lot newly built home 1490 sq ft 3 bedroom 2 bath attached 1 1/2 car garage by owner \$239 950 (810)217 7309 BRIGHTON 1000 sq ft ranch 3 bedroom 1 bath 2 car detached garage near 196 & US-23 Remodeled Lots of improvements First time buyers welcome \$142 900 248-240-9806 BRIGHTON 1000 sq ft ranch 3 bedroom 1 bath 2 car detached garage near 196 & US-23 Remodeled Lots of improvements First time buyers welcome \$142 900 248-240-9806 FOUR BEDROOM 1.5 bath colonial 1/2 acre close to x ways \$224 900/offer (810) 229 7372 APRIL SPECIAL \$219 900 for an 1800 sqft 3 bedroom brick ranch 2.5 bath c/a new kitchen extras 734 416 3884 AWESOME! Beautiful 3 bedroom 1.5 baths brick ranch in great neighborhood Family room fireplace 2 car garage & deep lot Updated kitchen windows doors & shing les Huge finished basement & home warranty Very clean Only \$194 900 Call Chris today! (734) 513 4563 Dynamic Realty Inc 8900 N Wayne Rd Westland

308 Canton

COLONIAL 3 bedroom 2.5 bath finished basement 2 car garage \$239 900 CALL CHRIS COURTNEY REMERICA HOMETOWN (734) 459 6222 EXTRA SPACIOUS Features new carpet ceramic tile Kitchen tayer & master bath 4 bedroom 2 1/2 bath finished basement new brick patio heated pool gazebo with new hot tub MUST SEE! \$270 000 734-459-7978 LARGE SUNFLOWER SUB colonial 4 bedrooms 2 1/2 baths approx 2700 sq ft immaculate cond w/ neutral decor and updates throughout By owner Asking \$292 000 (734) 459 3377 OPEN SUN 1 5pm 4 bedroom 3 1/2 bath colonial Inground pool finished basement \$319 500 47307 Northgate E of Beck S of Cherry Hill 734-495 3344 OUTSTANDING 4 bedroom 2.5 bath colonial in Sunflower Sub Neutral freshly painted interior exterior beautifully landscaped on premium corner lot \$317 900 Appt only (734) 459 6764 PHEASANT GLEN! Two bedroom 2 bath ranch condo great room w/two sky lights and fireplace basement 2 car garage \$219 000 CASTELLI & LUCAS (734) 453 4300 45500 FORD RD CANTON ROOM TO ROOM Set on 1.95 acres the 3 bedroom ranch at 47000 Hanford boasts towering trees country kitchen with fireplace Florida room with hot tub an attached garage utilized as workshop and storage 2 car detached garage spacious deck and an above ground pool Fred Hill 734 416 1257 Coldwell Banker Preferred SUNFLOWER VILLAGE Open Sun 1 4 This large main tenance free fully brick ranch has it all don't miss out \$254 900 734-459 7194 3296 sq ft colonial with open back yard 4 bedroom 2.5 baths formal living & dining Huge kitchen w/deck library & laundry on 1st floor Family room w/fireplace finished basement 3 car garage Charlotte Jancunski 734 377 3282 Century 21 Row 734-464-7111

308 Canton

THREE BEDROOM 2 1/2 bath ranch home New kitchen and bath newer windows & carpet hardwood floor in family room + fireplace 2.5 car garage full basement central air bay window in living room deck patio in ground pool w/new liner Cul de sac location large lot Plymouth Canton schools \$209 900 Jerry Parr (248) 408 5894 CENTURY 21 M/JL CORP TRANS SERVICE TUDOR QUAD All levels finished 1st floor laundry Lower bath has large Whirlpool Tub w/access to den Good location in sub \$228 500 (56FC) ROW (734) 464-7111 COLONIAL BRIGHT spacious 4 bedroom 2.5 bath Wooded setting garden basement + extras Realtor 248 625-5709 DEARBORN HGT'S 3 bedroom 2 full baths 1414 sq ft finished basement 2 car garage nice patio all appliances \$189 900 (313) 359 0442 LOTS OF UPDATES 4 bedroom bungalow with updated windows carpeting ceramic tile kitchen cabinets Family room w/fireplace Covered patio 20x20 car garage \$121 900 (734) 464-7111 ROW

314 Farmington/ Farmington Hills

BRICK 3 bedroom ranch in new condition 1977 sq ft 3 1/2 baths w/ jacuzzi vaulted ceilings 1st floor laundry air appliance large deck finished basement w/ bedroom bath and wet bar Attached 2 car garage Large wall unit w/ 52" T V \$316 900 (248) 788 9362 BRICK RANCH Contemporary 3 bedroom 2 1/2 bath home huge great room w/fireplace & wet bar formal dining room bright kitchen w/breakfast room 1st floor laundry nicely landscaped attached 2 car garage \$295 000 ON A COUNTRY LOT Beautiful 4 bedroom 3 bath brick colonial Large living room fireplace in family room library 26x13 dining room nice kitchen finished basement w/fireplace nicely landscaped w/circular drive attached 2 1/2 car garage \$430 000 CENTURY 21 Nada Inc 248 477 9800 FARMINGTON charming registered historic Victorian home in downtown Farmington 3 bed rooms 2 full baths wood floors throughout Barn with converted hayloft A must see \$290 000 (248) 474-1716 FARMINGTON HILLS Delightful 4 bedroom contemporary/open plan 2 1/2 bath 2600 sq ft partially finished basement great location Must See! \$319 500 (248) 489 0061 FARMINGTON HILLS Farmington schools Double lot updated newer roof electric windows Attached garage fenced yard with large trees Quick occupancy (248) 851 6700 CENTURY 21 M/JL CORP TRANS SERVICE FREE! SEARCH over 500 homes for sale in Farmington/ Farmington Hills online at www.LivingInFarmingtonHills.com This Classification Continued on Page 2F

517-546-9060 800-531-4449 Website: awesomeagents.com 204 West Grand River, Howell

STATE WIDE REALTY OF LIVINGSTON COUNTY awesomeagents.com 204 West Grand River, Howell HOWELL \$949 000 10 ACRES ESTATE 4 BR 4.5 BA Tudor Mt w/private entrance deck full W/O L-outdoor drng-stately yet practical & warm FOWLERVILLE \$179 900 WELL MAINTA NED 4 BR 2 BA 1800 sqft Flor de mar screened porch D n rm Study Brn-wkshp-lots of storage HOWELL \$279 900 VICTORIAN Cape Cod 3BR 2.5 BA Brnt Dec 48x30 garage w/12 ft doo-stone Frp D n rm lots of extras BIRMINGHAM \$238 500 4 BR 2 BA Frpl w/ marble ned Colon el-two 2 car garages-cul de sac covered deck-picturesque pond n back yard HOWELL \$169 900 ALMOST NEW RANCH 3 BR 2 BA Brnt-spl-ties gn + wooded rolling acres landscaped 2 car Att garage-Home Warranty HOWELL \$207 000 METICULOUS RANCH 2 BR 3 BA-completely F n L-Li-sun rm on back-Lge-cond in back & view of H eden Lk Home Warranty HOWELL \$229 900 REMODELED from foundation up-4 BR 2.5 BA LR DR Library-tasteful 2 acres-open fr-plan-covered porch-48x22 Det garage-corner lot HOWELL \$179 900 WATERFRONT 4 BR 1 BA LR DR Library-updated Ranch backs to Comm ponds-part Fin LL w/4th BR workshop-laundry-office OAKGROVE \$192 500 "MARTHA" decorated this 3 BR 2 BA Co onial fronts 37 acre Oak Grove M n Pond Lr Dr Lib fence ng-frpl shed-porch DANVILLE \$169 000 2+ ACRES w/pond-3 BR 2 BA 2Lw-Ranch-country Sub w/paved roads & driveway landscaped sprinkler system 1531 sqft home BYRON \$169 900 2.5 ACRES 3 BR 2 BA Ranch-part F n Brn pa lo-shed-deck-2 car Att garage-central a warm comfortable home MARION TWP \$57 900 each Par A corner lot of 3+ acres-Par B 3+ acres-Par C 3+ acres-spruces persc driveway permits approved Poss LC

30425 GREENLAND OPEN SUNDAY 4/28 1-4 P.M.

30425 GREENLAND OPEN SUNDAY 4/28 1-4 P.M. A once in a lifetime opportunity! This exceptional Livonia home is tucked away at the very end of a no outlet street on a parklike 150' x 250' acre lot. This fine home features 3 bedrooms, 1.5 baths on the main floor basement & oversized 2.5 car att gar Huge family room w/stone faced fireplace, bay window, custom oak floors & doorwall to deck Spectacular setting offers the utmost in privacy Yard is a gardener's dream come true! \$254 900 Call THOMAS GROSS 734-432-7600

Michigan's #1 CENTURY 21 Firm!

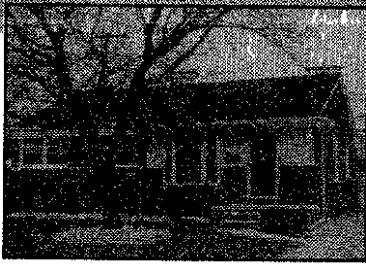

ABSOLUTE PERFECTION! Metcoulously maintained 3 BR 2 BA brick ranch Quality updates inside & out! Custom KIT & remodeled BA Neutral colors Freshly painted & newer carpet FIN BSMNT & 2 car garage \$149 999 (32 CAR) 734 455 5600

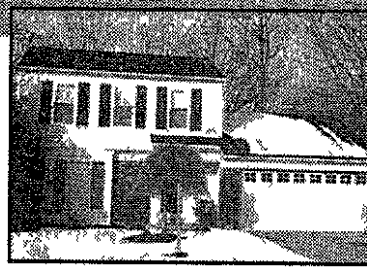

FROM ANY ANGLE! This home shows GREAT! From the Pergo floors to the deck and park like backyard you will smile with approval! Updated windows & carpet Open floor plan deck on a Cul de Sac location \$194 900 (81 LAR) 734-455 5600



DIFFERENT FLOOR PLAN! 3 BR 2 BA brick ranch with newer kitchen hardwood floors DR Newer (99) 2 car garage vinyl siding Newer windows (all but the front) Finished basement Large living room \$169 900 (81 SHE) 734-455 5600



BEAUTIFUL COLONIAL! 4 BR 2 5 BA HRDWD floors & neutral carpeting Large oak kitchen w/center island Large master suite w/garden tub Professionally landscaped sprinkler system and deck \$314 900 (88 HUN) 248 349-5600



APPROX 2 5 ACRES NEWER HOME! 3 large BRs 3 5 BA with finished basement library DR, 3 car garage skylit entry Master w/hers closet vanity & jetted tub Wet bar in butler pantry Tons of storage Great lot \$299 900 (11 FOU) 248 349-5600



DARLING REDFORD BUNGALOW! Great starter home You will love this charming bungalow with hardwood floors natural fireplace country front porch & DR 3 car garage heated work shop fenced yard with deck \$94 900 (12 NOR) 248 349-5600

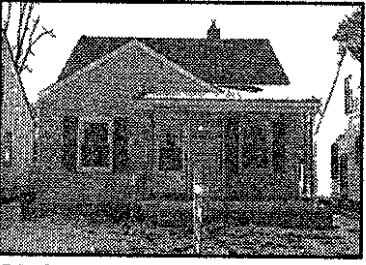

BRIGHT REDFORD BUNGALOW! Many updates-Newer vinyl siding windows doors & furnace 11x7 deck Partially FIN BSMNT & updated electric w/breakers Carpeted T/O Lots of storage FHA & VA \$109 900 (07 CEN) 734-455-5600

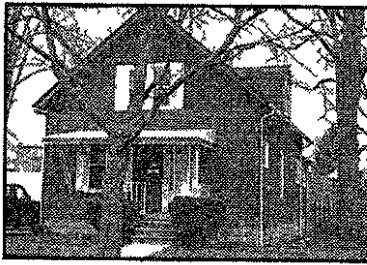

DOWNTOWN PLYMOUTH! 3 bed room 1 bath Approximately 1860 square feet with some updates Location and price cannot be beat! \$189 000 (06 MAP) 734-455-5600



REALLY NICE HOME! 3 BR 2 BA brick ranch with 2 car garage with newer vinyl siding (01) roof in 1999 Corner lot central air patio off easting area appliances stay Refinished hardwood floors basement \$149 899 (53 SIL) 734-455-5600

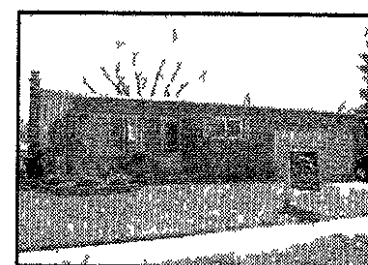

TERRIFIC! Updated 4 BR 2 BA with 2 car attached garage and basement Remodeled kitchen Family room with berber carpeting and fireplace Park-like fenced yard \$212 900 (56 ASP) 248-349-5600



GREAT STARTER HOME! This delightful 3 BR ranch is a must-see Light and bright with neutral decor Huge fenced yard backyard & attached garage \$142 000 (61 MAR) 248-349-5600



PARK LIKE SETTING! This 4 BR, 2 5 BA home sets on a large tree lot on a cul de-sac in this established family-oriented neighborhood Community pools tennis court, jogging paths Enjoy peacefulness \$232 900 (56 CAM) 248 349-5600



DISTRICT 7 SCHOOLS! Updated home on a double lot! LRG FR w/FPL & doorwall! MSTR BR w/designer closet doors & sitting area Formal DR & charming updated KIT w/island 1st FLR laundry Newer FURN \$145 000 (53 DET) 734-455 5600



FABULOUS CONDO! 2 BR 2 BA and unit condo back to nature preserve White Merlat kitchen Large MSTR w/Jacuzzi tub & skylight gas.FPL w/marble surround Hardwood floors LL is ready for bath \$214 900 (61 MEA) 734-455 5600



PLYMOUTH
705 South Main St.
734-455-5600

NORTHVILLE
175 CadyCentre
248-349-5600

Michigan's #1 Century 21 Firm!



CHARMING CAPE COD! 4 BR 1 5 BA well cared for home with partially finished basement C/A & hardwood floors Located on a double corner lot Many updates \$132 900 (51 BRO) 248-349 5600



LOCATION! LOCATION! Preferred Abbey Knoll offers 3 BR ranch with open floor plan for easy entertaining Large sunny GR and kitchen Decks at MBR and kitchen open to landscaped rear yard Northville Schools \$405 000 (74 WHI) 248-349-5600

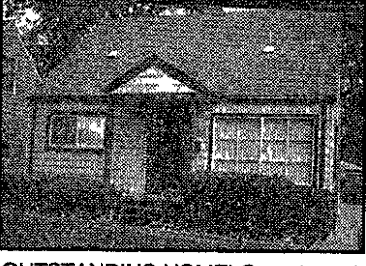

OUTSTANDING HOME! Great home! Beautiful yard! Ready to move in & enjoy! Stove refrig washer & dryer stay 5 ceiling fans & window A/C 3 BR par fin BSMNT & garage \$116 900 (68 FOX) 734-455-5600



UPPER UNIT 2 bedroom upper unit w/many updates kitchen bath all new carpets 03/02 stove refrigerator washer & dryer Seller offering home protection plan also \$109 990 (52 ORC) 734-455 5600

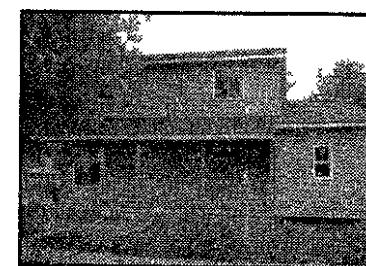

ALMOST TOTALLY REBUILT! Like new construction Quality built 3 BR 2 BA WIC 1st or 2nd floor MBR front & back porch newer furnace C/A roof and the list goes on Corner lot with room for a large garage \$112 500 (50 WIL) 248-349 5600



LUXURY EXECUTIVE HOME on over 1/2 acre deep sub Spacious rooms for entertaining Master suite with sitting room jacuzzi & oversized shower Large gourmet kitchen Fireplace and cathedral ceilings \$649 900 (46 HOL) 248 349 5600



WONDERFUL HOME! North Garden City 3 BR 1 5 BA ranch w/newer windows roof & HWH Beautiful oak KIT w/hardwood floors under Roof stripped 01 & finished basement with wet bar \$158 900 (45 GOL) 734 455 5600



PRIVATE WOODED LOT! Enjoy your privacy! Numerous updates White kitchen updated baths vinyl windows roof (within 1 yr) & C/A Open floor plan & fireplace Neutral decor \$209,900 (32 RAI) 734-455-5600

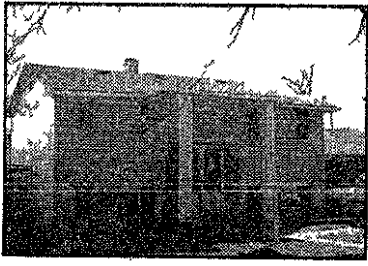

SPACE FOR THE DOLLAR! 4 BR 1 5 BA & attached garage with a large backyard in Westland! Newer roof & windows highlight this home with room for family Your decorating touch is all that is needed! \$149 900 (43 SOM) 734 455-5600

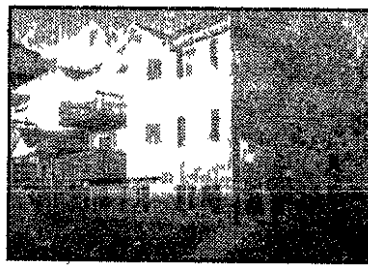

MOVE IN READY! 2 bedroom ground floor unit Clean & neutral All appliances stay Pergo floor in entry and kitchen Located in special complex in Plymouth with low association fee & taxes \$129 900 (43 PIN) 248 349 5600



CONTEMPORARY wooded acre Mahogany beveled glass front door open-flowing dream home 2 story great room with cathedral ceiling fireplace island kitchen 1st floor master & bath wooded backyard \$320 000 (00 COM) 248-349 5600



CONTEMPORARY NOVI CONDO Bright & sunny 2 BR 2 5 BA condo FR with gas fireplace Neutral color T/O Ceramic tile in foyer kitchen & baths Newer roof (01) private patio off FR \$177 900 (60 COU) 248 349-5600



COUNTRY HOME! Perfect setting! 100 x 150 wooded lot w/walking path LR w/newer berber carpet picture window BA w/pedestal sink & bay Newer roof some updated windows \$135 900 (01 HAR) 734-455 5600

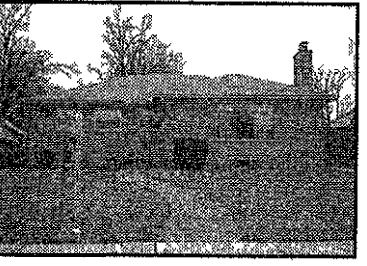

CUSTOM BUILT! 1950s brick ranch with many extras Oversized LR with plaster walls & hardwood floors 3 BR 2 BA FORM DR Updated kitchen 2 car attached garage with overhead storage \$174 500 (68 ROB) 734-455-5600

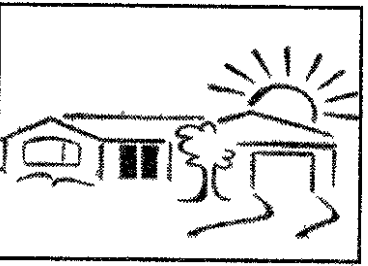

STOP! UPDATES GALORE! 3 BR 2 BA brick ranch with mechanic's dream garage 12 FT gazebo w/attached deck Wallside windows newer tile Berber carpet & FIN BSMNT w/4th BR/den Kitchen with half wall oak trim \$164 900 (80 STJ) 734-455 5600

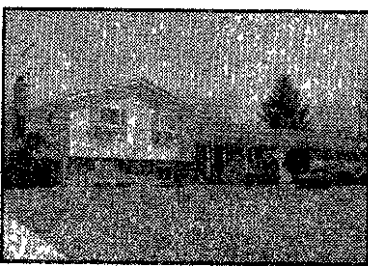

THE PERFECT PACKAGE! This spacious 3 BR 2 + 2 BA quad has been updated throughout Newer kitchen & baths Family room with fireplace library additional office or 1st floor guest suite Award winning schools \$289 900 (42 HEA) 248-349 5600

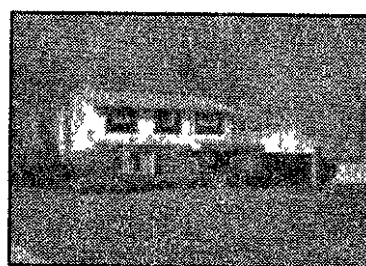

COLONIAL IN FARMINGTON HILLS! Do not hesitate on this terrific 4 BR 2 5 BA brick and alum home on large wooded lot Move in condition Newer maple updated kitchen, large square footage Ready for a new owner \$289 900 (01 SUM) 248-349-5600



SHOWN WITH PRIDE! Custom colonial with Northville schools Great family area 4 BR 3 BA 3 car garage - 2 years old Overlooks protected area 2 story foyer 9 ceilings walk-out lower level large cedar deck \$569 000 (80 BAR) 248 349-5600

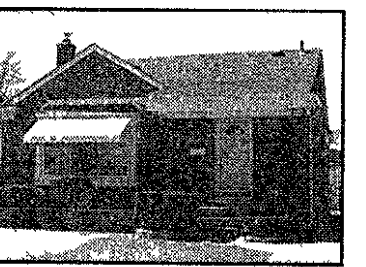

OWNER PRIDE! 3 BR brick ranch w/updated KIT baths roof windows furnace central air newer carpet added insulation new entry doors & updated plumbing Alarm SYS 1 5 car garage \$136 500 (85 HAZ) 734-455-5600



CUTE & CLEAN RANCH! Close to park & school! Updates include windows kitchen floors & counter fur new C/A & bath nice finished basement with bar pool table and glass block windows Freshly painted \$144 900 (25 ROS) 734-455 5600

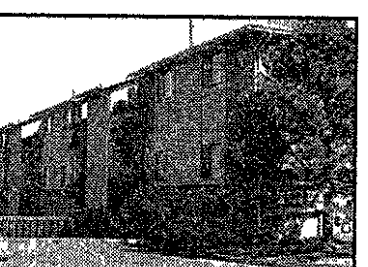

HARD TO FIND! Entry level ranch unit Neutral decor thru-out! Fireplace in LR w/access to deck overlooking commons & wooded area Large storage area in basement Appliances stay 1 car garage \$153 900 (91 SYC) 734-455 5600



SPACIOUS! 3 BR ranch on beautiful fenced corner lot Close to elementary school w/township taxes Newer roof furnace C/A and Reverse osmosis drinking system Hardwood in dining and bedrooms \$214 900 (80 VAL) 248 349 5600



PRIVACY & LUXURY COMBINED! Almost 6 acres of nature surrounds! This 1991 custom built home 3 BR 2 5 BA contemporary home Windows galore with spectacular views Close to shopping & freeways \$424 900 (75 PLE) 248-349 5600



BEAUTIFICATION AWARD was presented from the city to the owners of this gorgeous home 3 bedroom ranch w/attached garage Gas fireplace in living room natural fireplace in all year sun room Loads of updates Small pond in backyard \$243,900 (04SUN) 248 349-5600

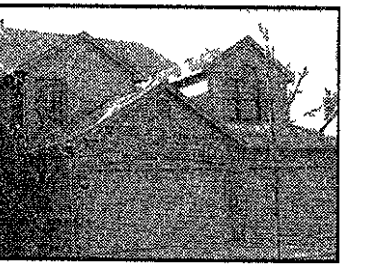

CARRIAGE PARK! 2 BR 2 5 BA condo w/soaring ceilings & open floor plan Master suite with extra closet space formal DR LR with oak mantle doorwall to patio 1st floor laundry \$185 900 (49 HOR) 734 455-5600

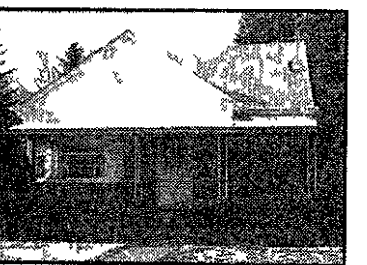

REDFORDS FINEST! Beautiful brick bungalow freshly paint throughout 1st floor carpet upper level hardwood floors Some newer windows updated furnace & water heater DR & MSTR w/ built ins \$126 900 (61 ROY) 734-455 5600



YOU MUST SEE THIS HOME! 3 BR brick ranch with 2 5 car garage & partially finished basement! Newer furnace & C/A updated electric & hard wood Fresh paint DR & HRWD floors under carpet Dearborn schools \$124 900 (48 VIR) 734-455 5600

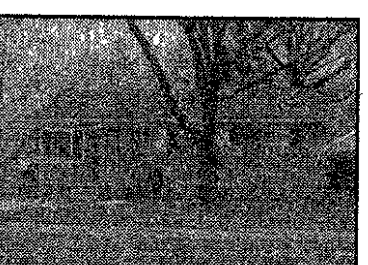

THIS IS THE ONE! Don't miss this great 3 BR ranch with newer roof & windows Family room with fireplace Newly painted inside & out Large fenced yard with deck Remodeled bath & laundry \$138 000 (80 HER) 248 349-5600



WONDERFUL CAPE COD! This custom built home sits on 1 acre Master BR on 1st floor 3 BRs up den custom kitchen full daylight basement att 3 5 garage Walking distance to a beautiful park Northville schools \$579 900 (92 HIL) 248-349-5600

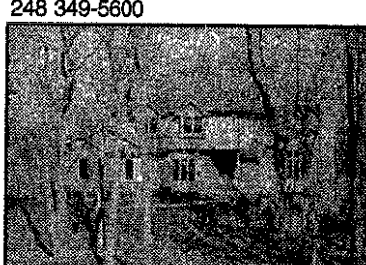

PICTURESQUE WOODED LOT Approx 1 acre 4 BR, 3 5 BA & custom throughout Private deck off master suite 2 story greatroom with fireplace Finished walk-out basement Extensive landscaping \$529,900 (61 SIL) 248-349-5600

294 E. Brown, Birmingham (248) 642-8100 4820 Rochester Road, Troy (248) 524-1600 2600 Union Lake, Commerce Twp. (248) 363-1200 722 W. University, Rochester (248) 652-8000 7125 Orchard Lake, West Bloomfield (248) 626-8800 705 S. Main St., Plymouth (734) 455-5600 175 Cady Centre, Northville (248) 349-5600

Website: <http://www.century21town-country.com>

- Complete Home Marketing Plan
- Home Warranty Program
- Local & Regional Multiple Listing Services
- Full-Service Relocation Services 1(800)448-5817
- Financing Services (810) 264-5400



403 Duplexes

WESTLAND 2 bedroom 1 bath Norwayne area \$525/month plus \$500 security deposit Call (734) 522-9356

WESTLAND Quiet neighbor hood Spacious ranch style 1 bedroom laundry room No pets \$650/mo (588) 817-1846

404 Flats

BIRMINGHAM 2 bedroom 1 bath wood floors washer/dryer garage \$1000/mo includes heat & water 248 406 7726

BIRMINGHAM 2 Bedroom spacious lower flat hardwood floors 1100 sq ft Washer/dryer \$1000/mo (248)760-0409

FERNDALE 2 bedroom lower flat completely renovated with new kitchen & bath hardwood floors dining room dishwasher basement \$995 per month (248) 407-1077

FERNDALE Charming large 2 bedroom lower Walk to downtown Fireplace central air washer & dryer parking garage & fenced yard Completely renovated with new Berber carpet & many updates A MUST SEE! \$950 plus utilities (248) 548-5946

GARDEN CITY Upper flat \$475/mo + security Utilities & appliances included 313 581 9420

PLYMOUTH 2 3 bedroom lower unit \$795/mo includes utilities & appliances yard basement very clean 873 N Holbrook 800-392-1063 X400 Agent

PLYMOUTH Charming downtown 1 bedroom upper & lower available Refinished wood floors new paint No pets/smoking \$595/\$675 mo with gas/water 734-354-1957

Plymouth Downtown 2 units 1 bedroom Appliances washer/dryer water air No pets \$560/\$700/mo 248 345 2552

PLYMOUTH OLD VILLAGE area 2 bedroom lower flat w/ mini blinds ceiling fans all appliances Available immediately No smokers & no pets \$820/mo (734) 459-4416

PLYMOUTH TWP 2 bedroom 1 bath lower large living & dining room shared access washer/dryer water & lawn included \$725/mo 248 736-5464

WAYNE Quiet 1 bedroom upper \$400/mo Includes heat & stove No pets Available June 1st 734-728-1477 after Noon

405 Homes

AAAAA Mortgage Services Your Tax Refund is The Key to Your New Home! \$0-\$1,995 Down Credit Problems Okay Call Ben Shunkwiler-RE/MAX HomeTeam 734 504 0356

405 Homes

AUBURN HILLS 4 bedroom 3 1/2 bath colonial Family room study all appliances 2 car garage Available now at \$1800 BLOOMFIELD TWP Large 4 bedroom 3 1/2 bath colonial on scenic canal to All Sports Upper Long Lake Finished walk out basement attached garage Available now at \$2100

TROY (Square Lake/Adams) 3 bedroom 1 1/2 bath ranch on large corner lot Attached garage all appliances pool Bloomfield Hills Schools Available May 15 at \$1500 Includes lawn GOODE (248) 647-1898 REAL ESTATE

BERKLEY 3 bedrooms 2 baths large family room 2 car garage w/carpot 2343 Thomas Available \$1100/mo (248) 814-8438

BERKLEY 2214 Beverly Blvd GREAT HOME! Spacious 2200 sq ft living space 3 bedroom 2 bath all newly remodeled large master suite hardwood floors large deck & yard beautifully finished basement pets negotiable \$1600 (734) 477-9177

ATTRACTIVE 3 bedroom colonial Sylvan Lake \$950/mo-deposit 2 bedroom ranch Big Lake Waterfront \$775/mo No pets (248) 559-8120

BIRMINGHAM A clean 3 bed room brick ranch on Southfield near Lincoln full basement 2 car garage Hardwood floors c/a all appliances for only \$1100/mo CARPENTER/MGMT LLC (248) 588-8900

BIRMINGHAM & ALL CITIES RENTALS SINCE 1976 OWNER & REALTOR@ LISTINGS HOUSES CONDOS APTS ShareNet Realty Leasing Management Sales 248-642-1620 725S Adams #19 Birmingham

BIRMINGHAM BEAUTIFUL 2 1/2 bedroom 15 bath garage basement \$1350 (248) 649-2341

Birmingham 4 Bedroom 1 1/2 baths living family & dining rooms c/a finished basement garage All Appliances \$1350 248-655-4411

BIRMINGHAM 2 3 bedroom 2 bath 2 car garage and close to downtown \$1450/mo 248 866 5963

BIRMINGHAM Charming 4 bedroom home w/cathedral ceilings & skylights \$1550/mo SHARENET (248)642-1620

BIRMINGHAM Cozy 2 bed rooms den hardwood & carpet 4 appliances Patio \$895/mo NO PETS 248-855-9081 www.wxmanagement.com

BIRMINGHAM dollhouse 2 bedroom vaulted ceilings sky lights 1100 sq ft short walk to town \$1250/mo (248)540-3198

BIRMINGHAM DOWNTOWN 2 bedroom 2 car garage base ment appliances C/A No pets or smokers \$940/mo Discount on 1st Mo! 248 626 2533

BIRMINGHAM FABULOUS 3 bedroom w/mother in law suite above 2 1/2 car garage \$2800/mo SHARENET (248)642-1620

BLOOMFIELD HILLS Awesome 4 bedroom updated throughout corner lot \$1995/mo SHARENET (248)642-1620

405 Homes

BLOOMFIELD Charming Cross/Wattles 2400sqft 3 bedroom 2 1/2 bath on 1 1/2 acre lot 2 fire places granite kitchen brick paver patio Birmingham schools \$2800/best 248-346-7123

BLOOMFIELD HILLS Great family sized 4 bedroom 3 1/2 bath home in a popular Bloomfield subdivision New kitchen carpet and paint Huge living room dining room with fireplace Family room with fireplace Bloomfield Hills schools \$2600/mo (LA#865)

HANNETT-WILSON & WHITEHOUSE (248) 646-6200

CANTON 3 bedroom 1 1/2 bath colonal 2 car attached garage basement 1st floor laundry living/dining room breakfast area family room with fireplace and water heater \$1200/mo with deck \$1450/mo immediate occupancy 734 981 4811 or cell 734 730-1977

CANTON 720 Scottsdale 2300 sq ft Brick colonial 4 bedrooms 3 1/2 baths family room finished basement w/Jacuzzi & sauna 2 car attached garage Appliances Shed fenced REDUCED TO \$1895/mo Avail able May 1st Show View Sat Sun @ 7pm 248 593 0044 Mobile 313-920-5866

CLARKSTON SALE/LEASE Luxury Living 3500 sq ft on 5 acres 175M-15 4 Bedroom 3 1/2 bath Short term available \$2800/mo or \$489700 Owner/Kathy 248-393-2481 481-709-6924 Prudential Chamberlain Stetl

CLAWSON 3 bedroom ranch appliances family room garage fenced yard \$850 RENTAL PROS (248)356-RENT

DEARBORN HGTS 3 bedroom \$900/mo rent or rent to own Leave day time number 734 713 0021

DEARBORN HGTS 3 bedroom bungalow fenced yard option to buy \$750 RENTAL PROS (734)513-RENT

DEARBORN Ranch remodel deck garage appliances new carpet deck \$750 RENTAL PROS (734)513-RENT

DEARBORN W Prime Historic District Brick colonial 3 bed room 1 1/2 bath family room finished basement fenced yard 2 car garage Available now \$1600/mo + security deposit & own utilities (313) 563-4371

FARMINGTON & ALL CITIES RENT A HOME TENANTS & LANDLORDS 248 642 1620

FARMINGTON HILLS 3 1/2 bedroom 4 bath (2 full) cape cod Basement garage car 6 Miles & 1 275 \$2200/mo Furnished option 248 228-0126

FARMINGTON HILLS 4 bedroom colonial garage c/a 2 1/2 baths ex location \$2200/mo (248) 737-8875

FARMINGTON HILLS 3 bed room appliances garage fenced yard pets neg \$825 RENTAL PROS (248)356-RENT

FARMINGTON HILLS Small 2 bedroom w/appliances no base ment no garage no laundry \$355/mo + utilities 248 357 4742

405 Homes

FERNDALE 3 bedroom base ment appliances dining room fenced yard \$750 RENTAL PROS (248)356-RENT

GARDEN CITY Available now carpeted water paid option to buy \$750 RENTAL PROS (734)513-RENT

GARDEN CITY 3 Bedroom 1 1/2 bath family room finished basement garage all appl ances & central air \$1200/mo 734 718 3495

GARDEN CITY WHY RENT Own your own home 0 to 3% down Short term employment OK credit problems OK bank ruptcy OK Call Randy Lesson Metro Finance 248 610 9576

HARPER WOODS 4 bedroom brick full basement 2 car garage completely remodeled \$1249 (513) 278-0282

KEEGO HARBOR Cass Lake water frontage 3 bedroom new kitchen attached garage appl ances \$1555/mo 248-227-8700

LAKE ORION 3 bedroom ranch appliances attached 2 car garage w/opener \$775 RENTAL PROS (248)373-RENT

LINCOLN PARK remodeled 3 bedroom basement option to buy available \$950/mo (248) 788 1823

LIVONIA 3 bedroom appl ances garage fenced yard for pets \$800 RENTAL PROS (734)513-RENT

LIVONIA 3 bedroom brick air appliances finished basement (734) 462 1408 (248)735 1650

LIVONIA 3 bedroom ranch 2 baths finished basement c/a 2 1/2 car garage fenced yard cov ered patio Non-smoker No pets \$1200/mo References Sec deposit 1 year lease Avail able May 1st (248) 474 2446

LIVONIA immaculate 3 bed room ranch 2 Bath appliances finished basement with 4th bed room 1 car garage central air fenced yard \$1200/mo Avail able July 1 734 422 8984

LIVONIA Stevenson School 3 bedroom ranch basement c/a 2 car Option fee payments negotiable (248) 471 5339

LIVONIA SW 3 bedroom 1 1/2 bath brick ranch w/basement & 2 1/2 car garage \$1300/mo 734 420 3400 ext 219

LIVONIA WHY RENT Own your own home 0 to 3% down Short term employment OK credit problems OK bankruptcy OK Call Randy Lesson Metro Finance 248 610 9576

MADISON HEIGHTS 2 bed room large kitchen 2 1/2 car garage c/a \$975/monthly (248) 552-0604

6 MILE/TELEGRAPH 3 bed room Ranch 1 1/2 bath basement 2 car small pet ok \$900/mo D&H Rentals (248)737-4002

MILFORD In The Village Charming 4 bedroom central air 2 baths 2 car garage deck \$1250/mo (248) 685 1487

NORTHVILLE Clean quiet 2 bedroom basement air garage near downtown No pets \$1200/mo (248) 474 0927

405 Homes

OAK PARK two newly remod eled 3 bedroom 1 bath base ments/private fenced yards Available May \$1000 \$1100 For info call (248) 955 1580

PLYMOUTH 3 bedrooms washer/dryer deck walk to Downtown \$1 395/mo 734 207 1497

PLYMOUTH TWP 2 Bedroom all appliances \$625/mo PETS ALLOWED Short or long term leases available 734-564-8062

PLYMOUTH TWP Updated Lake Pointe brick ranch 3 bed room 1 1/2 bath 2 1/2 car garage Pets negotiable 734 459-4101

PONTIAC Large 3-5 bedroom colonial finished basement garage Sec 8 ok \$850 RENTAL PROS (248)373-RENT

REDFORD 3 bedroom fin ished basement 2 baths C/A appliances \$900 RENTAL PROS (248)356-RENT

REDFORD Clean & updated 3 bedroom bungalow Basement fenced yard \$875/mo 15889 Lennane 248 701 2501

REDFORD Cute clean 2 bed room 1 bath fenced yard \$850/mo plus utilities Open Sun 5pm 7pm 14395 Seminole (Inkster & Lyndon)313-387 4751

REDFORD Rent to Own one of my houses Call to see if you qualify Many financing options available Don't wait! Call 734-564-2209 Agent

REDFORD TWP 2 bedrooms from \$685 3 bedrooms \$975 4 bedrooms \$1185 313-255-5678

REDFORD TWP BORDER 3 bedroom ceramic bath new appliances central air ceiling fans full basement 1 1/2 car garage fenced yard \$950 249-842-6616

REDFORD TWP New kitchen 3 bedrooms nice fenced yard \$895/mo plus 1 1/2 security Credit check 313-534-2044

REDFORD WHY RENT Own your own home 0 to 3% down Short term employment OK credit problems OK bankruptcy OK Call Randy Lesson Metro Finance 248 610 9576

RENT TO OWN One of my houses! Could be Zero Down For more info leave message 734 713 0021

ROCHESTER Avondale schools 4 bedroom appliances den basement Reduced \$975 RENTAL PROS (248)373-RENT

ROCHESTER Newly remod eled ranch appliances C/A jacuzzi tub \$795 RENTAL PROS (248)373-RENT

ROYAL OAK & ALL CITIES RENT A HOME TFNANTS & LANDLORDS 248-642-1620

ROYAL OAK 3 bedroom base ment appliances garage hard wood floors \$900 RENTAL PROS (248)356-RENT

ROYAL OAK near Downtown 4 bedrooms 2 baths all appl ances C/A hardwood floors updated kitchen \$1400/mo Call Margaret 248 866 7444 megmagnity@msn.com

SOUTHFIELD 2 bedroom appliances fenced yard Bir mingham schools \$750 RENTAL PROS (248)356-RENT

405 Homes

ROYAL OAK 411 N Gainsbor ough 2 bedroom 1 bath close to town washer/dryer garage fenced yard \$850/mo After 5pm 248 645 9620

SOUTH LYON 2 bedroom large lot new kitchen remod eled partially fenced near park \$800/mo (248) 486-0850

S REDFORD Available Now 3 bedroom brick ranch New kitchen/bath c/a 2 car garage \$1200/mo 734-487-7131

SYLVAN LAKE 20 s bungalow Absolutely charming Immacu late 3 bedroom 1 1/2 baths no pets \$1200 per mo (248) 738 8728

TROY 2 bedroom ranch appl ances dining room 2 car garage pets neg \$750 RENTAL PROS (248)373-RENT

TROY \$1495/mo Family size ranch 3 bedroom 2 bath Award winning schools Pets ok (248) 229 5440

TROY WEST Open Sun 1 1/2 Troy schools 4 bedroom 2 1/2 bath just remod eled \$2300/mo 958 Keaton Dr 313 319 3646 248-816 9889

WATERFORD Ranch on large lot appliances dining room shed, pets neg \$700 RENTAL PROS (248)373-RENT

WAYNE 2 & 3 bedrooms w/basements \$950 \$1100/mo Section 8 okay 734 504-4551

WAYNE Remodeled 3 bed room basement immediate occupancy Option to buy avail able \$850/mo (248) 788 1823

W BLOOMFIELD 4 bedroom 3 1/2 bath appliances air base ment 2 car garage porch 2550 sq ft \$2 495 (248) 737 2265

W BLOOMFIELD Nice sub w/lake privileges 3 bedroom ranch w/full basement C/A cathedral ceiling updated kitchen & bath 2 car garage \$1250/mo (810) 629-6622

WEST BLOOMFIELD-Gorgeous Union Lake frontage finished w/out 4 bedroom \$2000/mo SHARENET (248)642-1620

WEST BLOOMFIELD 2000 sq ft ranch 3 bedroom 2 bath dining living & family room w/fireplace c/a deck 2 car garage \$1525/monthly 248-855-4411

WESTLAND Act now! (Venoy Palmer) Clean 2 bedroom ranch fenced \$700/monthly (313) 274 6755

WESTLAND Affordable 2 bed room garage appliances avail able now \$600 RENTAL PROS (734)513-RENT

WESTLAND 2 Bedroom full basement New furnace with central air Ultra clean move night in From \$645/mo now thru Mar 31st 734 771 8111

WESTLAND 1 bedroom w/appliances Freshly dec orated 15 months security \$450/mo 810 231 7363

WESTLAND 3 bedroom garage fenced for pets option to buy \$790 RENTAL PROS (734)513-RENT

WESTLAND Ford Rd area 3 bedroom 1 1/2 bath finished basement c/a appliances No pets \$1050 (734) 591 9163

405 Homes

WESTLAND Remodeled 3 bed room brick finished basement C/A option to buy available \$1050/mo 248-788-1823 317 574-0633 317 867-8443

WESTLAND Rent to OWN one of my houses Call to see if you qualify Many financing options available Don't wait! Call Al 734-564-2209 Agent

WESTLAND Spottless 3 bed room brick ranch eat in kitchen large fenced yard c a finished basement walk to school \$1200/mo 734-878-5942

WESTLAND WHY RENT Own your own home 0 to 3% down Short term employment OK credit problems OK bankruptcy OK Call Randy Lesson Metro Finance 248 610 9576

406 Lake/Waterfront Home Rentals

HAMBURG TWP Cordley Lake 2 bedroom great fishing & swimming no motor lake \$850/mo 1 yr lease 248 624-1759

HARTLAND All sports lake 3 bedroom 2 bath open floor plan sharp ranch Pets nego tiable \$1395/mo (810) 632-6386

LEWISTON Sunny clean 4 bedrooms East 2nd Lake \$1000/wk 248 229 8898

NEW HAMPSHIRE cottage vacation treasure! Visit our website at www.beacamp.net for details pictures and rental info

407 Mobile Home Rentals

FARMINGTON HILLS 1 & 2 bedroom appliances window treatments, air No dogs Call (248) 474-2131

411 Vacation Resort Rentals

BURT LAKE Home on lake fully furnished Multiple families sleeps 16 (248)437-5339

CHARLEVOUX/ PETOSKY area 4 bedroom family chalet 2 bath on Lake Michigan shore \$1300/week (248) 477-9933

HARBOR SPRINGS Harbor Cove Condo 2 bedroom indoor/ outdoor pool Private beach Terms 231 798-8386

HARBOR SPRINGS luxury apt in town above The Depot 2 bedrooms 1 1/2 baths Sleeps 6 Washer/dryer 734-429-4630

LAKE MICHIGAN 3 bedroom cottage on the water S of Travers near Frankfort Summer and off season rental now available 248 258 9103

MAY-JUNE SPECIAL Sandcastles Port Austin 1 2 3 bedroom cottages pod cable kitchen sandy beach adjacent riding stable park Lake Huron sunset view From \$500 wk 313 822 0057 or 989 738-4200

MYRTLE BEACH South Caro lina 2 bedroom 2 bath luxury rooms condo on the ocean available year round weekly rental (313) 388 8093

411 Vacation Resort Rentals

NAPLES FL CONDO 3 mo rental 2 bedroom all appliances \$3 000 Bay view pool & covered parking 317 574-0633 317 867-8443

PEARL LAKE near Travers City New lakefront rental 3 bedroom sleeps 6-8 \$1500/week. Call 248-855-8476

PETOSKEY/HARBOR SPRINGS Beautiful furnished cottage on Crooked Lake 4 bedrooms 2 1/2 baths 3 car garage boat house with party loft \$1200/week Call Bob at 231-348-6979 GRAHAM REAL ESTATE

412 Living Quarters to Share

ALL CITIES SINCE 1976 QUALIFIED ROOMMATES FREE PREVIEW SHARE REFERRALS 248 642 1620 725 S Adams Birmingham

BEVERLY HILLS Beautifully furnished home Full house priv ileges FREE storage \$450/mo plus 1/2 utilities 248 352 5769

BLOOMFIELD ESTATE Spa cious home & grounds Young professional Lake pool All util ities \$365/mo 248 789 2335

LIVONIA separate entrance jacuzzi pool table cable TV full privileges \$150/wk \$600 last mo 734 612 1133

REDFORD TWP N of Grand River Professional seeking pro fessional 30 & up A/C & deck Safe clean private church neighborhood 313 682 0084

ROOMATE NEEDED Newly remodeled home in Birmingham \$600/mo (248) 855 5155

TROY Attractive home Female to share with same Fur nishing optional Non smoker no pets \$300/mo 586-596-5127

W BLOOMFIELD area Estate home on private lake female only \$500/mo plus utilities & deposit (248) 682 4377

WESTLAND Clean non smoking furnished 3 bedroom home full house privileges \$340/mo + 1/2 utilities 734-427-8351

414 Rooms

CANTON Near I 275 Chris tian non smoker or drinker quiet employed male \$325/mo New No lease 734 394 1557

LOOK FARMINGTON HILLS kitchen washer/dryer No smokers or pets \$325/mo includes utilities 248-755-1155

FERNDALE & REDFORD Air Jacuzzi in rooms maid service HBO Low daily/weekly rates Royal Inn 313 535 4100 Telal Inn 248-544-1575

LIVONIA MALE w/ince room in home kitchen bath & laundry Prefer conservative non smoking male/female \$350/mo A utilities Bill (248) 471 7486

NORTHVILLE or PLYMOUTH Downtown Furnished sleeping rooms Newly decorated \$75 weekly Security deposit 734-455-2010

414 Rooms

ROMULUS Female preferred Kitchen & laundry use Ecores & Merriman area. (313) 384-7032

WESTLAND Ford/Wayne Male has room to rent Prefer quiet student or professional \$100/wk (734) 326 2408

422 Office Space (See Class #386)

BRIGHTON 2 miles from I 96 Fully furnished attractive office suites All utilities included (810) 227 1551

DOWNTOWN NORTHVILLE Perfect location! Professional office space for rent comes with use of executive style confer ence room fit for 20 people Kitchen bathroom and parking all included Approx 350 sq ft building only 2 1/2 years old A must see on the inside to appreciate Please call Tomago (248) 349 6413

HIGHLAND EXECUTIVE office suite at Stonecrest complex 2 offices conference room secretary & reception area utilities included \$1500/mo (248)889-2167

HOLLY approximately 920 sq ft in beautiful historic downtown Holly on the famous Battle Alley Furniture avail able Call Grace Perry HomeTown Newspapers at (248) 349 1700

PLYMOUTH 1 080 & 982 sq ft medical space Haggerty/Ann Arbor Rd (Fairwood West II) Home Town Classifieds/Arnold Assoc (248)626 7557 Gary

423 Commercial/Ind. (See Class #394)

SOUTH LYON Light Industrial warehouse w/office 1500 to 2 300 sq ft Close to US 23 and I 96 (248) 437 6006

WIXOM 4500 sq ft easy access to free ways \$3100/mo Please call (810) 231-8205

440 Wanted to Rent

500 Help Wanted General
CENTER DIRECTOR CRD Consulting is conducting a confidential search for EXPERIENCED Child Care Center Director...

500 Help Wanted General
Construction Laborer \$11/Hour To Start Full Time NO experience necessary Call 248 736 0457

500 Help Wanted General
CUSTOMER SUPPORT ANALYST Ricoh Business Systems Inc (a subsidiary of Ricoh Corporation) is seeking a full time individual...

500 Help Wanted General
DOORPERSON/ CONCIERGE FOR new luxury condominium Customer service experience with high level of professional...

500 Help Wanted General
DRIVERS NEEDED Drive New Cars out/onto from Rail cars Full time good pay + benefits High school graduate w/clean driving record...

500 Help Wanted General
FINANCE DEPT Manufactured Home Retailer in New seeking full time individual for Finance Department...

500 Help Wanted General
FULL TIME & PART TIME INSIDE ADVERTISING SALES REPRESENTATIVE We are seeking enthusiastic result oriented individuals to join our sales team...

500 Help Wanted General
GROUNDS STAFF & POOL Franklin Square Apartments in Livonia is seeking seasonal pool & grounds staff...

500 Help Wanted General
SERVICE TECHNICIAN Hartford & Ratiff the hot water specialists needs experienced and qualified Technicians and installers...

CHILD CARE PROFESSIONALS NEEDED Learn While You Earn! The Learning Tree offers employees an Education reimbursement program...

COOKIE DECORATOR Full/Part time Will train Cookies by Design in Livonia Call Scott at (734) 422 0992

COOKS & DISHWASHER Competitive pay benefits BC/BS Sundays & major holidays off Apply at Red Coat Tavern 31542 Woodward Royal Oak

COUNTER CLERK Cleaners Royal Oak area Paid vacation and holidays Call (248) 280 1840

CPA Wanted for local accounting firm 1 position with 3-5 yrs & 1 position with 8+ yrs in public accounting exp Knowledge of QuickBooks Pro & Creative Solutions plus Large client base with opportunity for growth...

CREW CHIEFS Desine Inc a land survey and civil engineering firm located in Brighton is looking for responsible Crew Chiefs to direct field operations Responsibilities include construction Staking Boundary and topographic surveys We are an EOE employer with a competitive wage and benefits program...

CUSTOMER SERVICE REP Answer phones data entry scheduling calls Full or part time starting \$9/hr. Call Jean Attn Laura 248-353 5375

AIR FREIGHT SALES PROFESSIONAL Growing air freight for forwarding company CGL is looking for an experienced sales person Lucrative compensation program Please call Paul at 734-595 6165 www.CGLship.com

DIE MAKERS Min 5 yrs exp for Prog dies and Line dies Benefits days overtime Livonia 734-425 7102

DIRECT CARE ASSISTANT Provide services to developmentally disabled adults Variety of shifts Will train \$7.90 good benefit Call South Lyon area 734 662 4685 or 663 5637

DELIVERY / WAREHOUSE HELPER Full time opening for hard worker Helping w/roof top deliveries and in the warehouse when needed Must be customer oriented and able to lift up to 100 pounds...

DRIVER (CDL A or B) Service oriented customer needs drivers for roof top delivery Hard work repeat lifting of shingle bundles Majority of day spent roof loading Must be ok w/walking on roofs Clean driving record \$13.50 start (negotiable w/experience) BC/BS 401k & on going training! Apply at Wmsatt Building Materials 36340 Van Born Rd Wayne MI 48184

DRIVER (CDL A or B) \$1000 Signing Bonus for Experienced Full time Part time also available Full time position 401(k) medical with dental benefits available Westland Car Care Towing 6375 Hix Road Westland MI 48185

DRIVERS YOU WILL be home every night if you work for us If you possess a CDL A or B have 2 yrs local city driving experience pass a drug screen & have a good driving record We can put you to work CZ Cartage a local LTL carrier offers competitive wages excellent benefits including 401k & paid vacations Please call our HR Director at (248) 305 8300 ext 14 or complete an application & interview at CZ Cartage 48735 Grand River Nov

DRIVER WANTED CDL A required Local store door delivery 1 yr exp preferred Clean record Drug screen Commission salary benefits Call 8 5 313 584-4040 x 216

DRIVERS CDL A For local deliveries Paid medical & dental Call 7am 5pm 734-722 9581

DRIVERS LSG Sky Chefs the worlds largest Airlines is seeking drivers to DELIVER and CATERER our airline customers Qualifications CDL B permit strong customer service skills job responsibilities are physical nature and require a full range of motion lifting bending reaching and must be able to have 10 year verifiable background check PAY RATE \$12.47 All interested candidates must contact The Co by resume email or in person as follows LSG Sky Chefs HR Dept Detroit Metro Airport Building 505 Detroit MI 48242 Email DTW 1399JOBS@skychefs.com Park on side of building proceed to loading dock security checkpoint for application EEOC M/F/V/D

DRIVERS NEEDED Part/full time available Minimum require ments + 1 yr exp No accidents Non smoking single white male 48 Allen Rd Allen Park (313) 388 4900

DRIVERS WITH A CHAUFFEURS license for pulling trailers Retirees welcome (734) 771 4525

DRY CLEANER PRESSER Experience preferred Will train Full time Benefits Canton location 734-207 4992

DRY CLEANERS looking for counter help Walled Lake (248) 624 4333

ELECTRICAL ESTIMATOR with design & build experience Call (734) 744 0216 or Fax resume to (734) 744-0221

ELECTRICIAN NEW construction Commercial / Industrial Benefits 401K (248) 789 4032

ELECTRICIAN w/ underground experience Top pay good hours and benefits (313) 304 8844

EXPERIENCED Individuals Part time evening Office Cleaning Wed Thur & Fri Possible more Plymouth area Call 9am to 5pm Mon Fri 734-522 0983

EXPERIENCED TELEMARETERS Great 2nd job! Part time after noon shift Mon Thurs in Livonia area Ask for Keith (734) 432 5995

FLORAL Buschs is seeking a part time Floral Assistant for our Farmington Hills location at Farmington Hills Mall. Candidates will assist guests with product information merchandise department and do processing/displays of floral items Creativity and flair for guest service preferred We offer outstanding compensation and benefits Apply within at Buschs.com or call Human Resources at 734 944 4322 email jobs@buschs.com or visit us at www.buschs.com

GARDENER NEEDED full or part time Exp preferred Pay commensurate with exp Horticultural Services 734-485 1377

COSMETOLOGIST Full time summer help for Farmington Hills store Please apply within at 29218 Orchard Lake Rd Please ask for Manager Mon Fri 9-4pm

COSMETOLOGIST Part time help needed at Livonia Beaute Craft store Please apply within at 36155 Plymouth Rd Please ask for Manager Mon Fri 9-4pm

GRINDER Familiar with double disc grinders Must have knowledge to set machines up Comparable wages Apply at 13170 Merriman Livonia MI 48150

GRINDER HAND Five years exp Minimum Retirement plan & Benefits (248) 477 8040 Novi

GRONDS PERSON Needed for apartment community located in Southfield 40 hours/week Please call Ken at (248) 356-2431

GROUNDS PERSON Full time for Canton apartment community Great opportunity for right person Please call (734) 397 1080

GROUNDS PERSON Needed for WayneWood Apartments Summer work No faxed resumes please Apply in person 6737 N Wayne Rd Westland 734 326 2270

HAIRDRESSER/NAIL TECHS for new salon in Saline Exp ended w/clientele preferred Full service salon Call 734-429 3544 or 734 429 0765

HAIR STYLIST Livonia Salon Call Debbie (734) 464-7250 www.headsyouwin.com

HAIRSTYLIST NEEDED Full or part time for very busy Plymouth Salon located at 5th and Sheldon Walk-ins available Great opportunity in fast growing upscale area (734) 455 6833

HAIR STYLIST Rent a chair \$15/week (734) 422 5730

HAIRSTYLISTS Full Time Stylists Needed! With BORICS you will earn a guaranteed hourly wage PLUS commissions on services and retail We have Full time positions available at our salons in Troy on Rochester Rd and Lake Orion Township on Northland Dr. Call 1-800 668 8494 or apply online at www.BORICS.com

HANDYPERSON Experienced & motivated remodeling w/some all skills in carpentry drywall ceramic plumbing electrical & paint Must have own tools & transportation 248 476 2184

HEATING & COOLING INSTALLERS Tired of moving around? Master craft Heating & Cooling has immediate openings for experienced installers We offer excellent wages & benefits We also need helpers no experience necessary Call (313) 533 5700 from Noon 3pm only

HOUSEKEEPING SUPERVISOR Full time supervisory position for experienced housekeeper in a senior retirement facility Please apply at 3470 Carpenter Rd Ypsilanti MI Fax 734-677 0113

HVAC OUTSIDE SALES PERSON Residential W Side Carver/Lenox (734) 427 2564

HVAC PLUMBING & Refrigeration Commercial & Industrial Service Techs Supervisors & Sales/Estimators Full time BC/BS Dental 401(k) Vacation Holidays Education & Vehicle Call 313-535-4007 or 313-570M \$18-\$32 PER HOUR +

I'M GOING CRAZY!! Our Ad Agency is expanding and I need help fast!! Up to \$700/week NO Telemarketing! Call Shawn @ (734) 266 8159

HAIR STYLIST Livonia Salon Call Debbie (734) 464-7250 www.headsyouwin.com

HAIRSTYLIST NEEDED Full or part time for very busy Plymouth Salon located at 5th and Sheldon Walk-ins available Great opportunity in fast growing upscale area (734) 455 6833

HAIR STYLIST Rent a chair \$15/week (734) 422 5730

HAIRSTYLISTS Full Time Stylists Needed! With BORICS you will earn a guaranteed hourly wage PLUS commissions on services and retail We have Full time positions available at our salons in Troy on Rochester Rd and Lake Orion Township on Northland Dr. Call 1-800 668 8494 or apply online at www.BORICS.com

HANDYPERSON Experienced & motivated remodeling w/some all skills in carpentry drywall ceramic plumbing electrical & paint Must have own tools & transportation 248 476 2184

HEATING & COOLING INSTALLERS Tired of moving around? Master craft Heating & Cooling has immediate openings for experienced installers We offer excellent wages & benefits We also need helpers no experience necessary Call (313) 533 5700 from Noon 3pm only

HOUSEKEEPING SUPERVISOR Full time supervisory position for experienced housekeeper in a senior retirement facility Please apply at 3470 Carpenter Rd Ypsilanti MI Fax 734-677 0113

HVAC OUTSIDE SALES PERSON Residential W Side Carver/Lenox (734) 427 2564

HVAC PLUMBING & Refrigeration Commercial & Industrial Service Techs Supervisors & Sales/Estimators Full time BC/BS Dental 401(k) Vacation Holidays Education & Vehicle Call 313-535-4007 or 313-570M \$18-\$32 PER HOUR +

I'M GOING CRAZY!! Our Ad Agency is expanding and I need help fast!! Up to \$700/week NO Telemarketing! Call Shawn @ (734) 266 8159

HAIR STYLIST Livonia Salon Call Debbie (734) 464-7250 www.headsyouwin.com

HAIRSTYLIST NEEDED Full or part time for very busy Plymouth Salon located at 5th and Sheldon Walk-ins available Great opportunity in fast growing upscale area (734) 455 6833

HAIR STYLIST Rent a chair \$15/week (734) 422 5730

HAIRSTYLISTS Full Time Stylists Needed! With BORICS you will earn a guaranteed hourly wage PLUS commissions on services and retail We have Full time positions available at our salons in Troy on Rochester Rd and Lake Orion Township on Northland Dr. Call 1-800 668 8494 or apply online at www.BORICS.com

HANDYPERSON Experienced & motivated remodeling w/some all skills in carpentry drywall ceramic plumbing electrical & paint Must have own tools & transportation 248 476 2184

HEATING & COOLING INSTALLERS Tired of moving around? Master craft Heating & Cooling has immediate openings for experienced installers We offer excellent wages & benefits We also need helpers no experience necessary Call (313) 533 5700 from Noon 3pm only

HOUSEKEEPING SUPERVISOR Full time supervisory position for experienced housekeeper in a senior retirement facility Please apply at 3470 Carpenter Rd Ypsilanti MI Fax 734-677 0113

HVAC OUTSIDE SALES PERSON Residential W Side Carver/Lenox (734) 427 2564

HVAC PLUMBING & Refrigeration Commercial & Industrial Service Techs Supervisors & Sales/Estimators Full time BC/BS Dental 401(k) Vacation Holidays Education & Vehicle Call 313-535-4007 or 313-570M \$18-\$32 PER HOUR +

I'M GOING CRAZY!! Our Ad Agency is expanding and I need help fast!! Up to \$700/week NO Telemarketing! Call Shawn @ (734) 266 8159

CHILDTIME LEARNING Center is looking for qualified & energetic staff members Summer Camp Teachers Lead Teachers Classroom Aides Cook & Van Drivers Part & full time positions available. Benefits experience required Education preferred Call or stop in to day to join our team 32503 Ann Arbor Trail Westland MI 48185 734-425 7670

CHOIR DIRECTOR and/or Organist Prince of Peace Lutheran Church Westland 2 Sun service adult choir and bell choir Contact Jann Martin 734 722 1735

CLEANERS Commercial evenings part time \$8.50/hr to start Benefits available Call Joyce 248 478 8090

CLEANING TECH PART TIME Call Select One Restoration at 313-541 2100 or apply in person at 12282 Woodbine Redford

CNC MILL OPERATOR exp necessary 40 hrs per week + benefits 4978 Technical Dr Milford (248) 684-0555

CNC OPERATOR On molds ONLY Must have Heidenhain controller and work NC experience Apply at 13050 Inkster Rd (at 96) Redford

CONSTRUCTION Residential construction help wanted to fill Superintendent Service Manager and Punch Out positions Please fax resumes or qualifications to Mitch at (248) 642 1586

COUNTER PERSON BAKER & DELIVERY PERSON Full or part time Call (248) 960 9711

CREW CHIEFS Desine Inc a land survey and civil engineering firm located in Brighton is looking for responsible Crew Chiefs to direct field operations Responsibilities include construction Staking Boundary and topographic surveys We are an EOE employer with a competitive wage and benefits program...

CUSTOMER SERVICE REP Answer phones data entry scheduling calls Full or part time starting \$9/hr. Call Jean Attn Laura 248-353 5375

AIR FREIGHT SALES PROFESSIONAL Growing air freight for forwarding company CGL is looking for an experienced sales person Lucrative compensation program Please call Paul at 734-595 6165 www.CGLship.com

DIE MAKERS Min 5 yrs exp for Prog dies and Line dies Benefits days overtime Livonia 734-425 7102

DIRECT CARE ASSISTANT Provide services to developmentally disabled adults Variety of shifts Will train \$7.90 good benefit Call South Lyon area 734 662 4685 or 663 5637

DELIVERY / WAREHOUSE HELPER Full time opening for hard worker Helping w/roof top deliveries and in the warehouse when needed Must be customer oriented and able to lift up to 100 pounds...

DRIVER (CDL A or B) Service oriented customer needs drivers for roof top delivery Hard work repeat lifting of shingle bundles Majority of day spent roof loading Must be ok w/walking on roofs Clean driving record \$13.50 start (negotiable w/experience) BC/BS 401k & on going training! Apply at Wmsatt Building Materials 36340 Van Born Rd Wayne MI 48184

DRIVER (CDL A or B) \$1000 Signing Bonus for Experienced Full time Part time also available Full time position 401(k) medical with dental benefits available Westland Car Care Towing 6375 Hix Road Westland MI 48185

DRIVERS YOU WILL be home every night if you work for us If you possess a CDL A or B have 2 yrs local city driving experience pass a drug screen & have a good driving record We can put you to work CZ Cartage a local LTL carrier offers competitive wages excellent benefits including 401k & paid vacations Please call our HR Director at (248) 305 8300 ext 14 or complete an application & interview at CZ Cartage 48735 Grand River Nov

DRIVER WANTED CDL A required Local store door delivery 1 yr exp preferred Clean record Drug screen Commission salary benefits Call 8 5 313 584-4040 x 216

DRIVERS CDL A For local deliveries Paid medical & dental Call 7am 5pm 734-722 9581

DRIVERS LSG Sky Chefs the worlds largest Airlines is seeking drivers to DELIVER and CATERER our airline customers Qualifications CDL B permit strong customer service skills job responsibilities are physical nature and require a full range of motion lifting bending reaching and must be able to have 10 year verifiable background check PAY RATE \$12.47 All interested candidates must contact The Co by resume email or in person as follows LSG Sky Chefs HR Dept Detroit Metro Airport Building 505 Detroit MI 48242 Email DTW 1399JOBS@skychefs.com Park on side of building proceed to loading dock security checkpoint for application EEOC M/F/V/D

DRIVERS NEEDED Part/full time available Minimum require ments + 1 yr exp No accidents Non smoking single white male 48 Allen Rd Allen Park (313) 388 4900

FLORAL Buschs is seeking a part time Floral Assistant for our Farmington Hills location at Farmington Hills Mall. Candidates will assist guests with product information merchandise department and do processing/displays of floral items Creativity and flair for guest service preferred We offer outstanding compensation and benefits Apply within at Buschs.com or call Human Resources at 734 944 4322 email jobs@buschs.com or visit us at www.buschs.com

GARDENER NEEDED full or part time Exp preferred Pay commensurate with exp Horticultural Services 734-485 1377

COSMETOLOGIST Full time summer help for Farmington Hills store Please apply within at 29218 Orchard Lake Rd Please ask for Manager Mon Fri 9-4pm

COSMETOLOGIST Part time help needed at Livonia Beaute Craft store Please apply within at 36155 Plymouth Rd Please ask for Manager Mon Fri 9-4pm

GRINDER Familiar with double disc grinders Must have knowledge to set machines up Comparable wages Apply at 13170 Merriman Livonia MI 48150

GRINDER HAND Five years exp Minimum Retirement plan & Benefits (248) 477 8040 Novi

GRONDS PERSON Needed for apartment community located in Southfield 40 hours/week Please call Ken at (248) 356-2431

GROUNDS PERSON Full time for Canton apartment community Great opportunity for right person Please call (734) 397 1080

GROUNDS PERSON Needed for WayneWood Apartments Summer work No faxed resumes please Apply in person 6737 N Wayne Rd Westland 734 326 2270

HAIRDRESSER/NAIL TECHS for new salon in Saline Exp ended w/clientele preferred Full service salon Call 734-429 3544 or 734 429 0765

HAIR STYLIST Livonia Salon Call Debbie (734) 464-7250 www.headsyouwin.com

HAIRSTYLIST NEEDED Full or part time for very busy Plymouth Salon located at 5th and Sheldon Walk-ins available Great opportunity in fast growing upscale area (734) 455 6833

HAIR STYLIST Rent a chair \$15/week (734) 422 5730

HAIRSTYLISTS Full Time Stylists Needed! With BORICS you will earn a guaranteed hourly wage PLUS commissions on services and retail We have Full time positions available at our salons in Troy on Rochester Rd and Lake Orion Township on Northland Dr. Call 1-800 668 8494 or apply online at www.BORICS.com

HANDYPERSON Experienced & motivated remodeling w/some all skills in carpentry drywall ceramic plumbing electrical & paint Must have own tools & transportation 248 476 2184

HEATING & COOLING INSTALLERS Tired of moving around? Master craft Heating & Cooling has immediate openings for experienced installers We offer excellent wages & benefits We also need helpers no experience necessary Call (313) 533 5700 from Noon 3pm only

HOUSEKEEPING SUPERVISOR Full time supervisory position for experienced housekeeper in a senior retirement facility Please apply at 3470 Carpenter Rd Ypsilanti MI Fax 734-677 0113

HVAC OUTSIDE SALES PERSON Residential W Side Carver/Lenox (734) 427 2564

HVAC PLUMBING & Refrigeration Commercial & Industrial Service Techs Supervisors & Sales/Estimators Full time BC/BS Dental 401(k) Vacation Holidays Education & Vehicle Call 313-535-4007 or 313-570M \$18-\$32 PER HOUR +

I'M GOING CRAZY!! Our Ad Agency is expanding and I need help fast!! Up to \$700/week NO Telemarketing! Call Shawn @ (734) 266 8159

HAIR STYLIST Livonia Salon Call Debbie (734) 464-7250 www.headsyouwin.com

HAIRSTYLIST NEEDED Full or part time for very busy Plymouth Salon located at 5th and Sheldon Walk-ins available Great opportunity in fast growing upscale area (734) 455 6833

HAIR STYLIST Rent a chair \$15/week (734) 422 5730

HAIRSTYLISTS Full Time Stylists Needed! With BORICS you will earn a guaranteed hourly wage PLUS commissions on services and retail We have Full time positions available at our salons in Troy on Rochester Rd and Lake Orion Township on Northland Dr. Call 1-800 668 8494 or apply online at www.BORICS.com

HANDYPERSON Experienced & motivated remodeling w/some all skills in carpentry drywall ceramic plumbing electrical & paint Must have own tools & transportation 248 476 2184

HEATING & COOLING INSTALLERS Tired of moving around? Master craft Heating & Cooling has immediate openings for experienced installers We offer excellent wages & benefits We also need helpers no experience necessary Call (313) 533 5700 from Noon 3pm only

HOUSEKEEPING SUPERVISOR Full time supervisory position for experienced housekeeper in a senior retirement facility Please apply at 3470 Carpenter Rd Ypsilanti MI Fax 734-677 0113

HVAC OUTSIDE SALES PERSON Residential W Side Carver/Lenox (734) 427 2564

HVAC PLUMBING & Refrigeration Commercial & Industrial Service Techs Supervisors & Sales/Estimators Full time BC/BS Dental 401(k) Vacation Holidays Education & Vehicle Call 313-535-4007 or 313-570M \$18-\$32 PER HOUR +

I'M GOING CRAZY!! Our Ad Agency is expanding and I need help fast!! Up to \$700/week NO Telemarketing! Call Shawn @ (734) 266 8159

HAIR STYLIST Livonia Salon Call Debbie (734) 464-7250 www.headsyouwin.com

HAIRSTYLIST NEEDED Full or part time for very busy Plymouth Salon located at 5th and Sheldon Walk-ins available Great opportunity in fast growing upscale area (734) 455 6833

HAIR STYLIST Rent a chair \$15/week (734) 422 5730

HAIRSTYLISTS Full Time Stylists Needed! With BORICS you will earn a guaranteed hourly wage PLUS commissions on services and retail We have Full time positions available at our salons in Troy on Rochester Rd and Lake Orion Township on Northland Dr. Call 1-800 668 8494 or apply online at www.BORICS.com

HANDYPERSON Experienced & motivated remodeling w/some all skills in carpentry drywall ceramic plumbing electrical & paint Must have own tools & transportation 248 476 2184

HEATING & COOLING INSTALLERS Tired of moving around? Master craft Heating & Cooling has immediate openings for experienced installers We offer excellent wages & benefits We also need helpers no experience necessary Call (313) 533 5700 from Noon 3pm only

HOUSEKEEPING SUPERVISOR Full time supervisory position for experienced housekeeper in a senior retirement facility Please apply at 3470 Carpenter Rd Ypsilanti MI Fax 734-677 0113

HVAC OUTSIDE SALES PERSON Residential W Side Carver/Lenox (734) 427 2564

HVAC PLUMBING & Refrigeration Commercial & Industrial Service Techs Supervisors & Sales/Estimators Full time BC/BS Dental 401(k) Vacation Holidays Education & Vehicle Call 313-535-4007 or 313-570M \$18-\$32 PER HOUR +

I'M GOING CRAZY!! Our Ad Agency is expanding and I need help fast!! Up to \$700/week NO Telemarketing! Call Shawn @ (734) 266 8159

HAIR STYLIST Livonia Salon Call Debbie (734) 464-7250 www.headsyouwin.com

HAIRSTYLIST NEEDED Full or part time for very busy Plymouth Salon located at 5th and Sheldon Walk-ins available Great opportunity in fast growing upscale area (734) 455 6833

HAIR STYLIST Rent a chair \$15/week (734) 422 5730

HAIRSTYLISTS Full Time Stylists Needed! With BORICS you will earn a guaranteed hourly wage PLUS commissions on services and retail We have Full time positions available at our salons in Troy on Rochester Rd and Lake Orion Township on Northland Dr. Call 1-800 668 8494 or apply online at www.BORICS.com

HANDYPERSON Experienced & motivated remodeling w/some all skills in carpentry drywall ceramic plumbing electrical & paint Must have own tools & transportation 248 476 2184

HEATING & COOLING INSTALLERS Tired of moving around? Master craft Heating & Cooling has immediate openings for experienced installers We offer excellent wages & benefits We also need helpers no experience necessary Call (313) 533 5700 from Noon 3pm only

HOUSEKEEPING SUPERVISOR Full time supervisory position for experienced housekeeper in a senior retirement facility Please apply at 3470 Carpenter Rd Ypsilanti MI Fax 734-677 0113

HVAC OUTSIDE SALES PERSON Residential W Side Carver/Lenox (734) 427 2564

HVAC PLUMBING & Refrigeration Commercial & Industrial Service Techs Supervisors & Sales/Estimators Full time BC/BS Dental 401(k) Vacation Holidays Education & Vehicle Call 313-535-4007 or 313-570M \$18-\$32 PER HOUR +

I'M GOING CRAZY!! Our Ad Agency is expanding and I need help fast!! Up to \$700/week NO Telemarketing! Call Shawn @ (734) 266 8159

women seeking men Call 1-900-226-9960 \$2.19 per minute, \$2.19 per call connect fee

BE MY HERO be my soul mate take me golfing Looking for an active honest romantic adventurous upbeat nice guy who is not important I'm a white widow 60's enjoys golf travel romance good food and wine OK 11112

HARD TO FIND 62 yr old widowed white female 5'3 brown hair and eyes non smoker non-drinker enjoys music walks bicycling bingo church Seeks single white male 55 to 63 who enjoys life is honest and caring OK 13671

WORTH THE CALL Single white professional female would like to meet a single white professional male 40s to 60s for warm weather fun and other rewarding experiences OK 11109

HELP ON THE WAY Young looking 50 yr old woman 5'5 queen sized no children do

www.observerandeccentric.com

500 Help Wanted General

Laborers Needed Maintenance and cleaning of railroad railcars... Starting at \$8.50 plus Benefits

LANDSCAPE COMPANY Looking for hard working self motivated people for the following positions

LANDSCAPE FOREMAN LABORERS Valid drivers license desired Top \$\$ benefits available

LATHE HAND Five years exp Minimum Retirement Plan & Benefits (248) 477 8040

IRRIGATION TECH Experienced Good pay busy company Call Greg C 734-637 0220

LAWN CARE Hiring 3a Certified Applicators & Lawn Maintenance Crew 313 724 2480

LAWN / LANDSCAPING Plymouth based landscape company needs experienced landscape workers

LAWN MAINTENANCE Farmington Hills company seeking hard working responsible person for full time position

LEASING AGENT Accepting applications for full time Village Square Apartments (734) 981 8888

LEASING AGENT for retirement community in West Lake enthusiastic pleasant energetic real go-getter

LEASING AGENT Northville apartment community is looking for an experienced individual

LEASING AGENT Singh Management is seeking to fill immediate FULL TIME position for Briarcliff Village Apartments

LEASING AGENT Westland property Experience preferred but not required Apply in person

LEASING CONSULTANTS Full & Part time for Dearborn area apartment community

LEE S COLLISION Inquiring for Automotive Tech & Automotive Bump and Paint Technician (617) 946 4600

LEGAL COURTIERS Part time Retirees welcome Will train Own transportation (248) 423 2720

LEGAL INTERVIEWER Farmington Hills law office Excellent phone skills (248) 865 0860

LIFEGUARDS NEEDED at Beverly Hills Athletic Club Please call (248) 540 2986

LOAN OFFICER For Livonia mortgage broker Exp not required Top Day Leads provided Call Jill 734-542-3665

MACHINIST AUTOMOTIVE performance experienced person needed full time for auto parts store

MACHINIST CNC Machine Operator for light industrial Canton company Experience preferred

MAINTENANCE full time for apartment community in Westland Benefits available (734) 422 5411

500 Help Wanted General

MAINTENANCE Experienced (min 3 years) Apartment Maintenance position available for hard worker

MAINTENANCE GROUNDS SUPERVISOR For property management company properly \$10/hr Part time/full time (248) 868-8400

Maintenance Person \$9/hr +Benefits+401k For Novi apts Duties include unit prep grounds & pager Call 248 349 6612

MAINTENANCE Person needed for 146 unit Westland apartment community Must have basic skills in plumbing

MAINTENANCE Retiree community in West Lake looking for part time maintenance person

MAINTENANCE SUPERVISOR needed full time for large suburban apartment community

MANAGEMENT Part time for self storage assistant manager 2 days per week

MASON & MASON FOREMAN With commercial exp Top pay & fringes 248-437 7700

MASONRY Train to be mason good pay & benefits Requires good attitude

MECHANIC / HEAVY DUTY 20 year equipment related service business seeks motivated individual

MORTGAGE Loan Officer Trainers to \$125K/yr Terrific Benefits Base Salary Commission

MOTOR COACH OPERATORS CDL BP Lic required Must be DOT certified Minimum 3 years exp

NORTHVILLE LUMBER CO Counter Sales Lumber & Millwork 1 yr exp up to \$36K plus benefits

NURSERY SCHOOL SEEKS Summer Camp Counselors and Teaching Assistants for Fall 2002 school year

OFFICE CLEANERS & HOUSE CLEANERS NEEDED Will train Please call 313-543 7711

PAINTERS Interior & exterior exp Drywall exp Own transportation Call after 10am

PART-TIME OFFICE COORDINATOR Needed for Senior Housing Community in Detroit and Redford area

PLUMBER APPRENTICE Full time position in new construction Mechanically inclined dependable

Pool Maintenance Lawn Clean Up Summer help needed for large Townhouse complex in Auburn Hills

POOL MONITOR Starting Memorial Weekend thru Labor Day Must be 18 or older for apt

PRINTING Largest growing printing and communications company in the state looking for quality driven people

PRODUCTION ASSISTANT Fast growing automotive communications company in need of a detail oriented individual

500 Help Wanted General

PRODUCTION Full time help needed to assist in production but will accept part time Must be high school grad

PRODUCTION MANAGER Tier 1 automotive supplier seeks exp production floor supervisor

REAL ESTATE Career Office Sat May 4 at 11 am Topics Licensing requirements Profit sharing/investments

RECEPTIONIST For busy farmington Hills Salon Part time \$8/hr Please call (248) 626 8020

RECEPTIONIST Livonia Hair Salon Call Debbie (734) 464-7260 www.headysalon.com

RECEPTIONIST \$8 50 hr Mon thru Thurs 9:30am-4pm Will be Front Desk Greeter for permanent Employment Agency

REFRIGERATION TECH Exp with good driving record & ability to lift 70 lbs required

REPAIR PERSON Full time day position available with manufacturing firm Requires some heavy lifting

RESERVE POLICE OFFICER Canton Township is accepting applications for its volunteer Police Reserve Program

ROOFERS NEEDED Exp Laborers & Shinglers Exp in all mediums Call 313-887-6400

ROUGH FRAMERS WANTED 3 yrs exp Good pay good work atmosphere (248)770 6168

SEAMSTRESS Minor & major repairs Does not have to speak English Mar Kai Cleaners 313-537-8050

Security / Janitor Nights 10pm 6am full & part time positions available

HOUSEKEEPERS Full time days with benefits Apply in person Independence Village of Plymouth 14707 Northville Rd

SHIPPING AND RECEIVING at Lawn Equipment Distributor ship Mon Fri days Full time

SHIPPING & RECEIVING/ STOCK PERSON Needed for the Redford branch of an appliance parts distributor

SIDERS HELPER Transportation & dependability a must (734) 464-6346

500 Help Wanted General

SERVICE REPRESENTATIVE Lincare a national leader in respiratory and medical equipment

ACCOUNTING CLERK Needed for large GM dealer ship Auto dealership experience

ACCOUNTS PAYABLE CLERK Part time for Birmingham multi family property Mgmt Co

ADMINISTRATIVE ASSISTANT For tool shop Must have exp in A/P A/R inventory & job cost

ADMINISTRATIVE ASSISTANT For Southfield CPA firm Exp with Excel Word Access and general office duties

ADMINISTRATIVE ASSISTANT Now hiring for positions within a fast paced staffing company

ADMINISTRATIVE ASSISTANT/FRONT DESK Needed for busy Dr's office Experience a plus but will train

ADMINISTRATIVE ASSISTANT Investment firm seeks dynamic career oriented individual for administrative staff

ADMINISTRATIVE ASSISTANT Team player with a positive attitude needed for Dearborn Heights construction company

ADMINISTRATIVE MANGER for building materials center in Wayne Ideal candidate will have several years office management exp

EXECUTIVE ADMINISTRATIVE ASSISTANT Northville law firm seeking full time individual Must work in Wyandotte office

ADMINISTRATIVE SECRETARY Police Department The City of Plymouth Police Dept is accepting applications

CLOSER Title closing experience a must Closing Processor/DOC PREP

PLUMBERS Journeymen licensed well experienced residential Must be self motivated with positive attitude

AUTO DEALERSHIP PART TIME (SATURDAYS) OPERATOR CASHIER We need the right individual to work our busy Saturday sales staff

FRONT OFFICE PERSON For a medical office that deals with obesity related medical problems including diabetes and vascular disease

Full Charge Bookkeeper/Office Manager Full time for manufacturing/retail environment Minimum 5 yrs bookkeeping exp

BILLING SOFTWARE OPERATOR Some clerical and general office duties for Canton civil engineering firm

BOOKKEEPER CPA firm Strong computer skills & exp with FR taxes necessary

BOOKKEEPER Experienced to work in Tuxedo Rental shop in Livonia Plymouth Middlebelt area

BOOKKEEPER Farmington area Property Mgt Co seeks full time bookkeeper with A/R A/P P/R & P/R tax exp

BOOKKEEPER FOR full service construction company Able to handle accounts payable & accounts receivable

500 Help Wanted General

WELDER HELIARC & MIG Minimum 4 years experience Apply in person 85 13340 Marimont Road Livonia MI 48150

ACCOUNTING CLERK Needed for large GM dealer ship Auto dealership experience

ACCOUNTS PAYABLE CLERK Part time for Birmingham multi family property Mgmt Co

ADMINISTRATIVE ASSISTANT For tool shop Must have exp in A/P A/R inventory & job cost

ADMINISTRATIVE ASSISTANT For Southfield CPA firm Exp with Excel Word Access and general office duties

ADMINISTRATIVE ASSISTANT Now hiring for positions within a fast paced staffing company

ADMINISTRATIVE ASSISTANT/FRONT DESK Needed for busy Dr's office Experience a plus but will train

ADMINISTRATIVE ASSISTANT Investment firm seeks dynamic career oriented individual for administrative staff

ADMINISTRATIVE ASSISTANT Team player with a positive attitude needed for Dearborn Heights construction company

ADMINISTRATIVE MANGER for building materials center in Wayne Ideal candidate will have several years office management exp

EXECUTIVE ADMINISTRATIVE ASSISTANT Northville law firm seeking full time individual Must work in Wyandotte office

ADMINISTRATIVE SECRETARY Police Department The City of Plymouth Police Dept is accepting applications

CLOSER Title closing experience a must Closing Processor/DOC PREP

PLUMBERS Journeymen licensed well experienced residential Must be self motivated with positive attitude

AUTO DEALERSHIP PART TIME (SATURDAYS) OPERATOR CASHIER We need the right individual to work our busy Saturday sales staff

FRONT OFFICE PERSON For a medical office that deals with obesity related medical problems including diabetes and vascular disease

Full Charge Bookkeeper/Office Manager Full time for manufacturing/retail environment Minimum 5 yrs bookkeeping exp

BILLING SOFTWARE OPERATOR Some clerical and general office duties for Canton civil engineering firm

BOOKKEEPER CPA firm Strong computer skills & exp with FR taxes necessary

BOOKKEEPER Experienced to work in Tuxedo Rental shop in Livonia Plymouth Middlebelt area

BOOKKEEPER Farmington area Property Mgt Co seeks full time bookkeeper with A/R A/P P/R & P/R tax exp

BOOKKEEPER FOR full service construction company Able to handle accounts payable & accounts receivable

502 Help Wanted-Office Clerical

BOOKKEEPER Northville office looking for a take charge bookkeeper Postion includes full responsibility for A/R A/P & G/L Fax resume to 734 283 1293

BOOKKEEPER Oakland County property management company seeking an experienced person to handle commercial building & shopping center property management

BOOKKEEPER Part time Tues Wed & Thurs for custom machine builder in Plymouth

BOOKKEEPER SECRETARY/SALES PERSON Century 21 Town & Country has an opening for a part time Receptionist

CUSTOMER SERVICE Livonia area home improvement co seeks qualified individual to help set up customer service

CUSTOMER SERVICE Personal Lines Insurance Customer Service Rep needed for Nov insurance agency

CUSTOMER SERVICE Full time temporary help needed (May Sept) Mon Fri 8am to 5pm

Customer Service Inside Sales Great opportunity for an ambitious individual with mechanical aptitude

MOELLER MFG CO 49398 Plymouth Oaks Blvd Plymouth MI 48150 Fax 734-416-2200

DOWNTOWN PLYMOUTH office is accepting applications for a full time position that requires good attitude and computer skills

EXECUTIVE ADMINISTRATIVE ASSISTANT Northville law firm seeking full time individual Must work in Wyandotte office

ADMINISTRATIVE SECRETARY Police Department The City of Plymouth Police Dept is accepting applications

CLOSER Title closing experience a must Closing Processor/DOC PREP

PLUMBERS Journeymen licensed well experienced residential Must be self motivated with positive attitude

AUTO DEALERSHIP PART TIME (SATURDAYS) OPERATOR CASHIER We need the right individual to work our busy Saturday sales staff

FRONT OFFICE PERSON For a medical office that deals with obesity related medical problems including diabetes and vascular disease

Full Charge Bookkeeper/Office Manager Full time for manufacturing/retail environment Minimum 5 yrs bookkeeping exp

BILLING SOFTWARE OPERATOR Some clerical and general office duties for Canton civil engineering firm

BOOKKEEPER CPA firm Strong computer skills & exp with FR taxes necessary

BOOKKEEPER Experienced to work in Tuxedo Rental shop in Livonia Plymouth Middlebelt area

BOOKKEEPER Farmington area Property Mgt Co seeks full time bookkeeper with A/R A/P P/R & P/R tax exp

BOOKKEEPER FOR full service construction company Able to handle accounts payable & accounts receivable

502 Help Wanted-Office Clerical

OFFICE ASSISTANT Part time flexible part time position available at local midsize CPA firm

OFFICE CLERICAL PART TIME Weight Watchers has an exciting opportunity in our Human Resources Department

RECEPTIONIST For busy Real Estate office in the Northville/Novi area Clerical & phone experience required

RECEPTIONIST Immediate opening for entry level receptionist position in fast growing property management office

OFFICE EMPLOYEE Basic computer and accounting skills office experience Retirees welcome (313) 562 5800

OFFICE HELP Full time temporary help needed (May Sept) Mon Fri 8am to 5pm

OFFICE MANAGER Required skills include A/P A/R payroll month end & quarterly reporting

OFFICE STAFF Take charge person with tele phone and computer experience filing skills for sales office

PURCHASING/CUSTOMER SERVICE Full or part time Experienced outgoing detail oriented self starter

RECEPTIONIST AND GENERAL OFFICE Full Time Good phone skills and dealership experience preferred

RECEPTIONIST / CLERICAL needed for busy Livonia real estate office Must have phone computer and good general office skills

RECEPTIONIST / ENTRY LEVEL OFFICE ASSISTANT Northville law firm seeking full time candidate who must possess professional telephone skills

RECEPTIONIST For law firm Must have exp in Good benefits and starting salary Fax resume to (248) 351 2211

RECEPTIONIST Full & Part time mature responsible person for Down town Northville hair salon

RECEPTIONIST FULL TIME SOUTHWEST OFFICE LOCATION Ambitious & energetic person to be responsible for Multi-line office Full benefits Please send resume to

RECEPTIONIST Full or Part time for Farmington Hills management company Call (734) 729 0710

RECEPTIONIST FULL TIME SOUTHWEST OFFICE LOCATION Ambitious & energetic person to be responsible for Multi-line office Full benefits Please send resume to

RECEPTIONIST Full or Part time for Farmington Hills management company Call (734) 729 0710

RECEPTIONIST FULL TIME SOUTHWEST OFFICE LOCATION Ambitious & energetic person to be responsible for Multi-line office Full benefits Please send resume to

RECEPTIONIST Full or Part time for Farmington Hills management company Call (734) 729 0710

RECEPTIONIST FULL TIME SOUTHWEST OFFICE LOCATION Ambitious & energetic person to be responsible for Multi-line office Full benefits Please send resume to

RECEPTIONIST Full or Part time for Farmington Hills management company Call (734) 729 0710

502 Help Wanted-Office Clerical

RECEPTIONIST Full or Part time good pay for medical supply co in Farmington Hills Fax resume to 248 335 8652

RECEPTIONIST Great opportunity in a friendly environment Answer phones general office duties & working with people

RECEPTIONIST HELP wanted for animal clinic Full/part time Westland area 734 595 6500

RECEPTIONIST/ASSISTANT Immediate full time position for Birmingham law firm Duties include handling multiple phone lines

RECEPTIONIST/SECRETARY Mature dependable person to work part time evenings and weekends Must be available to train during the day

RECEPTIONIST Seeking a highly motivated individual for a fast paced & growing insurance agency

RECEPTIONIST We are seeking a professional and reliable individual to be a full time Receptionist in our Lake Orion office

RECEPTIONIST/CLERICAL needed for busy Livonia real estate office Must have phone computer and good general office skills

RECEPTIONIST AND GENERAL OFFICE Full Time Good phone skills and dealership experience preferred

RECEPTIONIST / CLERICAL needed for busy Livonia real estate office Must have phone computer and good general office skills

RECEPTIONIST / ENTRY LEVEL OFFICE ASSISTANT Northville law firm seeking full time candidate who must possess professional telephone skills

RECEPTIONIST For law firm Must have exp in Good benefits and starting salary Fax resume to (248) 351 2211

RECEPTIONIST Full & Part time mature responsible person for Down town Northville hair salon

RECEPTIONIST FULL TIME SOUTHWEST OFFICE LOCATION Ambitious & energetic person to be responsible for Multi-line office Full benefits Please send resume to

RECEPTIONIST Full or Part time for Farmington Hills management company Call (734) 729 0710

RECEPTIONIST FULL TIME SOUTHWEST OFFICE LOCATION Ambitious & energetic person to be responsible for Multi-line office Full benefits Please send resume to

RECEPTIONIST Full or Part time for Farmington Hills management company Call (734) 729 0710

RECEPTIONIST FULL TIME SOUTHWEST OFFICE LOCATION Ambitious & energetic person to be responsible for Multi-line office Full benefits Please send resume to

RECEPTIONIST Full or Part time for Farmington Hills management company Call (734) 729 0710

RECEPTIONIST FULL TIME SOUTHWEST OFFICE LOCATION Ambitious & energetic person to be responsible for Multi-line office Full benefits Please send resume to

RECEPTIONIST Full or Part time for Farmington Hills management company Call (734) 729 0710

RECEPTIONIST FULL TIME SOUTHWEST OFFICE LOCATION Ambitious & energetic person to be responsible for Multi-line office Full benefits Please send resume to

502 Help Wanted-Office Clerical

The Suburban Collection We now have the following full time positions available ACCOUNT RECEIVABLE CLERK

RECEPTIONIST Great opportunity in a friendly environment Answer phones general office duties & working with people

RECEPTIONIST HELP wanted for animal clinic Full/part time Westland area 734 595 6500

RECEPTIONIST/ASSISTANT Immediate full time position for Birmingham law firm Duties include handling multiple phone lines

RECEPTIONIST/SECRETARY Mature dependable person to work part time evenings and weekends Must be available to train during the day

RECEPTIONIST Seeking a highly motivated individual for a fast paced & growing insurance agency

RECEPTIONIST We are seeking a professional and reliable individual to be a full time Receptionist in our Lake Orion office

RECEPTIONIST/CLERICAL needed for busy Livonia real estate office Must have phone computer and good general office skills

RECEPTIONIST AND GENERAL OFFICE Full Time Good phone skills and dealership experience preferred

RECEPTIONIST / CLERICAL needed for busy Livonia real estate office Must have phone computer and good general office skills

RECEPTIONIST / ENTRY LEVEL OFFICE ASSISTANT Northville law firm seeking full time candidate who must possess professional telephone skills

RECEPTIONIST For law firm Must have exp in Good benefits and starting salary Fax resume to (248) 351 2211

RECEPTIONIST Full & Part time mature responsible person for Down town Northville hair salon

RECEPTIONIST FULL TIME SOUTHWEST OFFICE LOCATION Ambitious & energetic person to be responsible for Multi-line office Full benefits Please send resume to

RECEPTIONIST Full or Part time for Farmington Hills management company Call (734) 729 0710

RECEPTIONIST FULL TIME SOUTHWEST OFFICE LOCATION Ambitious & energetic person to be responsible for Multi-line office Full benefits Please send resume to

RECEPTIONIST Full or Part time for Farmington Hills management company Call (734) 729 0710

RECEPTIONIST FULL TIME SOUTHWEST OFFICE LOCATION Ambitious & energetic person to be responsible for Multi-line office Full benefits Please send resume to

RECEPTIONIST Full or Part time for Farmington Hills management company Call (734) 729 0710

RECEPTIONIST FULL TIME SOUTHWEST OFFICE LOCATION Ambitious & energetic person to be responsible for Multi-line office Full benefits Please send resume to

RECEPTIONIST Full or Part time for Farmington Hills management company Call (734) 729 0710

RECEPTIONIST FULL TIME SOUTHWEST OFFICE LOCATION Ambitious & energetic person to be responsible for Multi-line office Full benefits Please send resume to

KRAMER TRAD HOME SERVICES 248/888 4714

MAINTENANCE full time for apartment community in Westland Benefits available (734) 422 5411

MACHINIST CNC Machine Operator for light industrial Canton company Experience preferred

LEGAL COURTIERS Part time Retirees welcome Will train Own transportation (248) 423 2720

POOL MONITOR Starting Memorial Weekend thru Labor Day Must be 18 or older for apt

PRINTING Largest growing printing and communications company in the state looking for quality driven people

PRODUCTION ASSISTANT Fast growing automotive communications company in need of a detail oriented individual

SEAMSTRESS Minor & major repairs Does not have to speak English Mar Kai Cleaners 313-537-8050

HOUSEKEEPERS Full time days with benefits Apply in person Independence Village of Plymouth 14707 Northville Rd

SHIPPING AND RECEIVING at Lawn Equipment Distributor ship Mon Fri days Full time

SHIPPING & RECEIVING/ STOCK PERSON Needed for the Redford branch of an appliance parts distributor

SIDERS HELPER Transportation & dependability a must (734) 464-6346

TRUCK DRIVER CDL A for Plymouth co local deliveries Com petitive wages Full benefits bonuses (517) 223 7339

TRUCK DRIVER Must have Chauffeurs License & good driving record Apply in person

Observer & Eccentric MARKET PLACE

www.observerandeccentric.com

504 Help Wanted-Dental

DENTAL HYGIENIST Needed part time Monday evenings 3:30-7:00 for a friendly team player for family care office (734) 427-7555

DENTAL RECEPTIONIST Specialty practice is looking for a special person to join the dental team. This special person must have dental experience and be self motivated organized articulate and empathetic Salary \$30-\$45,000 + benefits Call (248) 357-3100

DENTAL RECEPTIONIST/EXPERIENCED Needed full time in our Bloomfield Hills office. Excellent people skills and insurance knowledge a must. No Sat or evenings Call (248) 542-0400

DENTAL RECEPTIONIST For periodontal practice Part time some Saturdays Dental exp necessary Farmington Hills area 248-851-4167

DENTAL RECEPTIONIST Family oriented practice in Livonia Full time in modern friendly office Looking for person who enjoys interacting with people Computer & insurance experience preferred No weekends Fax resume to 734-427-1233 Or call 734-427-7555

FRONT DESK GREAT OFFICE & staff Full time Dental experience & computer knowledge a must Livonia 734-425-4206

Healthcare

DENTAL ASSISTANT Exp needed Full time/part time Bloomfield Hills office (248) 335-4427

MOTIVATED HYGIENIST needed 29 hrs per week for contemporary Farmington Hills office Benefits negotiable Please call (248) 855-3655

506 Help Wanted

ADP TotalSource a leader in the Professional Employer Organization industry is seeking a highly motivated professional with strong client relation skills ADP TotalSource is recognized as an Employer of Choice with highly competitive compensation benefits and advancement opportunities. The following position is available in our Novi-Michigan location

401(k) SPECIALIST Strong organizational skills attention to detail and excellent computer and customer service skills required Need 3-4 years 401(k) experience knowledge of 401(k) plan designs and administration compliance and government regulations a willingness to travel ability to research and resolve complex issues related to 401(k) plans skills needed to develop and perform internal 401(k) training Interested candidates should send resume cover letter and salary requirements

ADP TotalSource A PEO one Stop Employer Service P.O. Box 435 Novi MI 48376 or Fax to 248 374-8765

AESTHETICIAN Skin Deep is looking for a licensed Aesthetician to work in its Bloomfield Hills location Full & part time positions available Call 248 647-2886 and ask for Susan or Rena

A growing billing company seeking experienced MEDICAL BILLERS • Full time • Benefits • Great opportunity Fax resume to 313 240 7301

AUDIOLOGIST & OPTOMETRIST needed for busy health practice Please call (248) 324-1173 Fax (248) 324-1450

BILLING ASSISTANT For laboratory in Garden City Full time 9am-5pm Monday thru Friday Position includes data entry filing & telephone Fax resume to 734-762-0530

BIRMINGHAM OB/GYN needs Receptionist Good pay and benefits Recent Exp 248 647 9860 EXTENSION 245

CAREER MINDED INDIVIDUAL with a medical background to work in a busy alternative healthcare practice Must have experience & willing to work 35-40 hours in a 4 day work week 401(k)/benefits Send resume to D H S 38595 W Ten Mile #112 Novi MI 48375

CENAS Afternoons Full & Part time Days Part time Apply in person Marycrest Manor 15475 Middlebelt Livonia MI 48154

CHIROPRACTIC ASSISTANT Permanent part time morning position available Mon Wed Thurs & Fri 8:45-12:30 Tues & Sat 8:45-10:30 Clerical skills necessary willing to train qualified person 2727 Loy Rd (1/2 blk W of Inkster Rd) 734 522 5501

DIRECT CAREGIVERS For group homes in Plymouth Garden City & Bellevue Afternoons and Days (Garden City Only) Must have good driving record \$7.30 \$7.80/hr Call Garin 248 980 3309

ER OR PEDIATRIC NURSES Currently hiring experienced nurses with critical thinking skills to provide telephone triage service in a progressive professional call center We are seeking candidates who are • Highly Motivated • Team Players • Independent • 3 yrs clinical experience Accepting applications for part time and contingent positions We have 4 and 8 hour shifts available Send resume & salary requirements to Huron Valley Ambulance 2215 Hogback Rd Ann Arbor MI 48105 Attn Con Sulting Nurses EOE

FRONT DESK RECEPTIONIST / FILING Medical experience only Full time Novi 248-465-1460

Healthcare

MEDICAL ASSISTANT needed for multi specialty office in Canton Good benefits pleasant environment Eves needed (734) 961-1086

MEDICAL ASSISTANT Part-Time Will train Mon & Thurs afternoon Sat Mornings Fax resume (248) 851-0173

506 Help Wanted-Medical

LABORATORY SUPERVISOR Two excellent opportunities to enhance your professional career as a department Supervisor in a growing laboratory and industry leader. Comprehensive benefit package Min 5 years technical exp required Manage ment exp not required

HCL Core Lab (Southfield) Afternoon shift Chemistry Department flexible starting time

Providence Hospital (Main Campus) Day shift Chemistry Department

Send or fax resume to Hospital Consolidated Laboratories Attn: GSA 23775 Northwestern Hwy Southfield MI 48075 Fax 248-358-1311

MEDICAL ASSISTANT/LPN/RN Medical examiners needed to perform mobil medical evaluations Must have good physical skills and reliable car Pay is a percentage of gross-mileage All shifts avail Fax resume to 866-522-5200

MEDICAL ASSISTANT For Urology office full time excellent benefits Can fax or mail resume to fax 248-557-1863 or mail to Urology Associates 17100 Twelve Mile Rd Suite 3 Southfield MI 48076 attention Kay

MEDICAL ASSISTANT/RECEPTIONIST 30-40hrs per week Exp preferred will train PFT and venipuncture Fax resume to 734-422-4475

MEDICAL ASSISTANT Immediate opening for experienced medical assistant for orthopedic surgeon in Garden City Team player people skills required Mon-Fri Full or part time fax resume to 734-422-6273

MEDICAL ASSISTANT/RECEPTIONIST 30-40hrs per week Exp preferred will train PFT and venipuncture Fax resume to 734-422-4475

MEDICAL ASSISTANT Immediate opening for experienced medical assistant for orthopedic surgeon in Garden City Team player people skills required Mon-Fri Full or part time fax resume to 734-422-6273

MEDICAL ASSISTANT/RECEPTIONIST 30-40hrs per week Exp preferred will train PFT and venipuncture Fax resume to 734-422-4475

MEDICAL ASSISTANT Immediate opening for experienced medical assistant for orthopedic surgeon in Garden City Team player people skills required Mon-Fri Full or part time fax resume to 734-422-6273

MEDICAL ASSISTANT/RECEPTIONIST 30-40hrs per week Exp preferred will train PFT and venipuncture Fax resume to 734-422-4475

MEDICAL ASSISTANT Immediate opening for experienced medical assistant for orthopedic surgeon in Garden City Team player people skills required Mon-Fri Full or part time fax resume to 734-422-6273

MEDICAL ASSISTANT/RECEPTIONIST 30-40hrs per week Exp preferred will train PFT and venipuncture Fax resume to 734-422-4475

MEDICAL ASSISTANT Immediate opening for experienced medical assistant for orthopedic surgeon in Garden City Team player people skills required Mon-Fri Full or part time fax resume to 734-422-6273

MEDICAL ASSISTANT/RECEPTIONIST 30-40hrs per week Exp preferred will train PFT and venipuncture Fax resume to 734-422-4475

MEDICAL ASSISTANT Immediate opening for experienced medical assistant for orthopedic surgeon in Garden City Team player people skills required Mon-Fri Full or part time fax resume to 734-422-6273

MEDICAL ASSISTANT/RECEPTIONIST 30-40hrs per week Exp preferred will train PFT and venipuncture Fax resume to 734-422-4475

MEDICAL ASSISTANT Immediate opening for experienced medical assistant for orthopedic surgeon in Garden City Team player people skills required Mon-Fri Full or part time fax resume to 734-422-6273

MEDICAL ASSISTANT/RECEPTIONIST 30-40hrs per week Exp preferred will train PFT and venipuncture Fax resume to 734-422-4475

MEDICAL ASSISTANT Immediate opening for experienced medical assistant for orthopedic surgeon in Garden City Team player people skills required Mon-Fri Full or part time fax resume to 734-422-6273

MEDICAL ASSISTANT/RECEPTIONIST 30-40hrs per week Exp preferred will train PFT and venipuncture Fax resume to 734-422-4475

MEDICAL ASSISTANT Immediate opening for experienced medical assistant for orthopedic surgeon in Garden City Team player people skills required Mon-Fri Full or part time fax resume to 734-422-6273

MEDICAL ASSISTANT/RECEPTIONIST 30-40hrs per week Exp preferred will train PFT and venipuncture Fax resume to 734-422-4475

MEDICAL ASSISTANT Immediate opening for experienced medical assistant for orthopedic surgeon in Garden City Team player people skills required Mon-Fri Full or part time fax resume to 734-422-6273

MEDICAL ASSISTANT/RECEPTIONIST 30-40hrs per week Exp preferred will train PFT and venipuncture Fax resume to 734-422-4475

MEDICAL ASSISTANT Immediate opening for experienced medical assistant for orthopedic surgeon in Garden City Team player people skills required Mon-Fri Full or part time fax resume to 734-422-6273

MEDICAL ASSISTANT/RECEPTIONIST 30-40hrs per week Exp preferred will train PFT and venipuncture Fax resume to 734-422-4475

MEDICAL ASSISTANT Immediate opening for experienced medical assistant for orthopedic surgeon in Garden City Team player people skills required Mon-Fri Full or part time fax resume to 734-422-6273

MEDICAL ASSISTANT/RECEPTIONIST 30-40hrs per week Exp preferred will train PFT and venipuncture Fax resume to 734-422-4475

MEDICAL ASSISTANT Immediate opening for experienced medical assistant for orthopedic surgeon in Garden City Team player people skills required Mon-Fri Full or part time fax resume to 734-422-6273

MEDICAL ASSISTANT/RECEPTIONIST 30-40hrs per week Exp preferred will train PFT and venipuncture Fax resume to 734-422-4475

MEDICAL ASSISTANT Immediate opening for experienced medical assistant for orthopedic surgeon in Garden City Team player people skills required Mon-Fri Full or part time fax resume to 734-422-6273

MEDICAL ASSISTANT/RECEPTIONIST 30-40hrs per week Exp preferred will train PFT and venipuncture Fax resume to 734-422-4475

MEDICAL ASSISTANT Immediate opening for experienced medical assistant for orthopedic surgeon in Garden City Team player people skills required Mon-Fri Full or part time fax resume to 734-422-6273

MEDICAL ASSISTANT/RECEPTIONIST 30-40hrs per week Exp preferred will train PFT and venipuncture Fax resume to 734-422-4475

MEDICAL ASSISTANT Immediate opening for experienced medical assistant for orthopedic surgeon in Garden City Team player people skills required Mon-Fri Full or part time fax resume to 734-422-6273

MEDICAL ASSISTANT/RECEPTIONIST 30-40hrs per week Exp preferred will train PFT and venipuncture Fax resume to 734-422-4475

MEDICAL ASSISTANT Immediate opening for experienced medical assistant for orthopedic surgeon in Garden City Team player people skills required Mon-Fri Full or part time fax resume to 734-422-6273

MEDICAL ASSISTANT/RECEPTIONIST 30-40hrs per week Exp preferred will train PFT and venipuncture Fax resume to 734-422-4475

MEDICAL ASSISTANT Immediate opening for experienced medical assistant for orthopedic surgeon in Garden City Team player people skills required Mon-Fri Full or part time fax resume to 734-422-6273

MEDICAL ASSISTANT/RECEPTIONIST 30-40hrs per week Exp preferred will train PFT and venipuncture Fax resume to 734-422-4475

MEDICAL ASSISTANT Immediate opening for experienced medical assistant for orthopedic surgeon in Garden City Team player people skills required Mon-Fri Full or part time fax resume to 734-422-6273

MEDICAL ASSISTANT/RECEPTIONIST 30-40hrs per week Exp preferred will train PFT and venipuncture Fax resume to 734-422-4475

MEDICAL ASSISTANT Immediate opening for experienced medical assistant for orthopedic surgeon in Garden City Team player people skills required Mon-Fri Full or part time fax resume to 734-422-6273

MEDICAL ASSISTANT/RECEPTIONIST 30-40hrs per week Exp preferred will train PFT and venipuncture Fax resume to 734-422-4475

MEDICAL ASSISTANT Immediate opening for experienced medical assistant for orthopedic surgeon in Garden City Team player people skills required Mon-Fri Full or part time fax resume to 734-422-6273

MEDICAL ASSISTANT/RECEPTIONIST 30-40hrs per week Exp preferred will train PFT and venipuncture Fax resume to 734-422-4475

MEDICAL ASSISTANT Immediate opening for experienced medical assistant for orthopedic surgeon in Garden City Team player people skills required Mon-Fri Full or part time fax resume to 734-422-6273

MEDICAL ASSISTANT/RECEPTIONIST 30-40hrs per week Exp preferred will train PFT and venipuncture Fax resume to 734-422-4475

MEDICAL ASSISTANT Immediate opening for experienced medical assistant for orthopedic surgeon in Garden City Team player people skills required Mon-Fri Full or part time fax resume to 734-422-6273

MEDICAL ASSISTANT/RECEPTIONIST 30-40hrs per week Exp preferred will train PFT and venipuncture Fax resume to 734-422-4475

MEDICAL ASSISTANT Immediate opening for experienced medical assistant for orthopedic surgeon in Garden City Team player people skills required Mon-Fri Full or part time fax resume to 734-422-6273

MEDICAL ASSISTANT/RECEPTIONIST 30-40hrs per week Exp preferred will train PFT and venipuncture Fax resume to 734-422-4475

MEDICAL ASSISTANT Immediate opening for experienced medical assistant for orthopedic surgeon in Garden City Team player people skills required Mon-Fri Full or part time fax resume to 734-422-6273

MEDICAL ASSISTANT/RECEPTIONIST 30-40hrs per week Exp preferred will train PFT and venipuncture Fax resume to 734-422-4475

MEDICAL ASSISTANT Immediate opening for experienced medical assistant for orthopedic surgeon in Garden City Team player people skills required Mon-Fri Full or part time fax resume to 734-422-6273

MEDICAL ASSISTANT/RECEPTIONIST 30-40hrs per week Exp preferred will train PFT and venipuncture Fax resume to 734-422-4475

MEDICAL ASSISTANT Immediate opening for experienced medical assistant for orthopedic surgeon in Garden City Team player people skills required Mon-Fri Full or part time fax resume to 734-422-6273

MEDICAL ASSISTANT/RECEPTIONIST 30-40hrs per week Exp preferred will train PFT and venipuncture Fax resume to 734-422-4475

506 Help Wanted-Medical

RECEPTIONIST, FRONT DESK Full time for professional medical office Excellent benefits Must come to PO Box 826 Birmingham MI 48012 0826

RESIDENT AIDE Part or Full time afternoons for an assisted living facility Must be dependable Please apply in person at 15775 Middlebelt in Livonia Or Call 734 522 5780

RESPIRATORY THERAPIST Lincare a national leader in respiratory and medical equipment in the home is seeking a Respiratory Therapist to place in a leadership position This position requires a motivated self starter with a positive attitude who enjoys a challenge and is driven to succeed

Responsibilities include patient care management as well as patient/physician interaction

Lincare provides a competitive salary and benefits/401K and profit sharing

Proper credentials/education and experience required Fax or Mail resume to LINCARE INC c/o Center Manager 39943 Schoolcraft Livonia MI 48150 Fax 734 432 0159 EOE M/F

RN LPN OR MA With experience needed for GROWING Dermatology practice in Ann Arbor/Plymouth area Pay commensurate with exp Full time Exc benefits Fax Resume Today (734) 936-3757

RESTAURANT MANAGERS Salary PLUS outstanding benefits health insurance and paid vacations Little Daddy's Restaurant calls Ken 248 855 2800

OAK MANAGEMENT INC is currently looking for a Sous Chef in S Western Oakland County This is a full time salary and position with medical benefits available Also offered is a 401k plan and vacation days Salary range from \$28,000 to \$34,000 per yr Please call 248 693 8307

TRUMPS NOW HIRING Servers Bartenders Shot Girls and part time Cook Apply in person between 4pm-7pm Mon Thurs 21413 W 8 Mile Detroit MI 48219 (313) 592 1190

WAITPERSON With bar experience needed for part time evenings Canton bar (734) 487 9770

WAITSTAFF + DISHWASHER Part/full time Days or Nights Apply at Konec's Inn Inn Livonia Mall 7 & Middlebelt

508 Food/Beverage Restaurant Accepting Applications for immediate openings BREAKFAST COOK LINE COOK SAUTE COOK HOST/STRESS WAIT STAFF Full Benefit Package including 401k

BEVERLY HILLS GRILL 31471 Southfield Road Between 13 & 14 Mile Rds

ASSISTANT BANQUET CHEF experienced Flexible hours part/full time Hartland Ferry (810) 632 6401

ATTENTION EXPERIENCED Pizza Makers and Drivers Needed for new pizza shop Apply at 32933 Warren at Venoy

BUSSERS, PART TIME Needed at Huron River Club Apply in person at the rear entrance between 1-4pm Tues Sat 22575 Farmington Rd Farmington (248) 477 1000

AM COOK/FULL TIME For Retirement Center in Farmington Hills Benefits included (248) 473 7183

COOK APPLY now Gatsby's 45701 Grand River between Taft & Beck in growing Novi (248)348-6999

ASSISTANT COOK We are looking for an experienced dependable individual to fill our Assistant Cook position Full time in a senior retirement facility. Please apply at American Hour Carpenter 3470 Carpenter Rd Ypsilanti MI 48197 Fax to 734 677 0113

COOKS WANTED All Shifts DOYLES TAVERN 734 207 9656

COOKS WANTED Full & Part time Brae Burn Golf Course Plymouth MI 1 800 714 6700 or 734-453 1900

A Career IN Real Estate Free Training Location Location SE Corner of Six/Haggerty Ask for Larry Frey or Frank D'Angelo

Century 21 Hartford South Inc 734 464 8400 www.c21hs.com

DISCOVER THE DIFFERENCE Call Jim Stevens or Alissa Nead

COLDWELL BANKER PREFERRED REALTORS (734) 459-8000

A Career IN Real Estate Free Training Location Location SE Corner of Six/Haggerty Ask for Larry Frey or Frank D'Angelo

Century 21 Hartford South Inc 734 464 8400 www.c21hs.com

DISCOVER THE DIFFERENCE Call Jim Stevens or Alissa Nead

COLDWELL BANKER PREFERRED REALTORS (734) 459-8000

A Career IN Real Estate Free Training Location Location SE Corner of Six/Haggerty Ask for Larry Frey or Frank D'Angelo

Century 21 Hartford South Inc 734 464 8400 www.c21hs.com

DISCOVER THE DIFFERENCE Call Jim Stevens or Alissa Nead

COLDWELL BANKER PREFERRED REALTORS (734) 459-8000

A Career IN Real Estate Free Training Location Location SE Corner of Six/Haggerty Ask for Larry Frey or Frank D'Angelo

Century 21 Hartford South Inc 734 464 8400 www.c21hs.com

DISCOVER THE DIFFERENCE Call Jim Stevens or Alissa Nead

COLDWELL BANKER PREFERRED REALTORS (734) 459-8000

A Career IN Real Estate Free Training Location Location SE Corner of Six/Haggerty Ask for Larry Frey or Frank D'Angelo

Century 21 Hartford South Inc 734 464 8400 www.c21hs.com

DISCOVER THE DIFFERENCE Call Jim Stevens or Alissa Nead

COLDWELL BANKER PREFERRED REALTORS (734) 459-8000

A Career IN Real Estate Free Training Location Location SE Corner of Six/Haggerty Ask for Larry Frey or Frank D'Angelo

Century 21 Hartford South Inc 734 464 8400 www.c21hs.com

DISCOVER THE DIFFERENCE Call Jim Stevens or Alissa Nead

COLDWELL BANKER PREFERRED REALTORS (734) 459-8000

A Career IN Real Estate Free Training Location Location SE Corner of Six/Haggerty Ask for Larry Frey or Frank D'Angelo

Century 21 Hartford South Inc 734 464 8400 www.c21hs.com

DISCOVER THE DIFFERENCE Call Jim Stevens or Alissa Nead

COLDWELL BANKER PREFERRED REALTORS (734) 459-8000

A Career IN Real Estate Free Training Location Location SE Corner of Six/Haggerty Ask for Larry Frey or Frank D'Angelo

Century 21 Hartford South Inc 734 464 8400 www.c21hs.com

DISCOVER THE DIFFERENCE Call Jim Stevens or Alissa Nead

COLDWELL BANKER PREFERRED REALTORS (734) 459-8000

A Career IN Real Estate Free Training Location Location SE Corner of Six/Haggerty Ask for Larry Frey or Frank D'Angelo

Century 21 Hartford South Inc 734 464 8400 www.c21hs.com

DISCOVER THE DIFFERENCE Call Jim Stevens or Alissa Nead

COLDWELL BANKER PREFERRED REALTORS (734) 459-8000

A Career IN Real Estate Free Training Location Location SE Corner of Six/Haggerty Ask for Larry Frey or Frank D'Angelo

Century 21 Hartford South Inc 734 464 8400 www.c21hs.com

DISCOVER THE DIFFERENCE Call Jim Stevens or Alissa Nead

COLDWELL BANKER PREFERRED REALTORS (734) 459-8000

A Career IN Real Estate Free Training Location Location SE Corner of Six/Haggerty Ask for Larry Frey or Frank D'Angelo

508 Food/Beverage Restaurant

Cooking Do You Love to Cook? Busch's may have the opportunity for you! We are seeking cooking gurus to do in store demonstrations of different products share recipes help people make food decisions recommend product and show off their culinary talent We have all the ingredients right at your fingertips Position is part time and requires someone with a creative flair Please apply at 24445 Drake Rd in Farmington Hills or call Human Resources at 734 944 4322 email jobs@buschs.com or visit us at www.buschs.com

COOK Waltonwood at Cherry Hill is seeking an experienced COOK for our new independent Luxury Senior Apartment community in Canton Part time/Full time position with benefits EEO Send resume to Administrator 42800 Cherry Hill Canton MI 48187 For Fax to (734) 981 2829

FULL OR PART TIME apply in person Athens Cafe inside Livonia Mall 7 Mile & Middlebelt Ask for Betsy

FULL TIME / PART TIME Flexible hours apply in person Tubby's 16686 Middlebelt (N of 5 Mile)

INDUSTRIAL CATERING HOT TRUCK Route for driving with option to buy Good driving record Experience preferred (734) 414-9993

Restaurant/Clubs

KITCHEN HELP WANTED 7am-3pm Mon thru Fri Weekend & holidays off Health benefits & 401K Call Chef Jeff 248 699 8019

RESTAURANT MANAGERS Salary PLUS outstanding benefits health insurance and paid vacations Little Daddy's Restaurant calls Ken 248 855 2800

OAK MANAGEMENT INC is currently looking for a Sous Chef in S Western Oakland County This is a full time salary and position with medical benefits available Also offered is a 401k plan and vacation days Salary range from \$28,000 to \$34,000 per yr Please call 248 693 8307

TRUMPS NOW HIRING Servers Bartenders Shot Girls and part time Cook Apply in person between 4pm-7pm Mon Thurs 21413 W 8 Mile Detroit MI 48219 (313) 592 1190

WAITPERSON With bar experience needed for part time evenings Canton bar (734) 487 9770

WAITSTAFF + DISHWASHER Part/full time Days or Nights Apply at Konec's Inn Inn Livonia Mall 7 & Middlebelt

512 Help Wanted-Sales

A CAREER IN REAL ESTATE! LOOK NO FURTHER If you desire to work in western Wayne county be with number 1 see our other ad for details Call Sherry Hetkowsky 734 392 6000

COLDWELL BANKER PREFERRED REALTORS

A NEW CAREER? REAL ESTATE IS BOOMING! Excellent Commissions Great Training DOUG COURTNEY REMERICA HOMETOWN (734) 459 6222

AN EXCITING REAL ESTATE OPPORTUNITY

MARKET PLACE

All Ads Run Online FREE! A Value Of Up To \$87.00

www.observerandeccentric.com

Merchandise #700-778

700 Absolutely Free

BENCH SEAT 3 person fits Aerostar (313) 933-0231

DOGHOUSE Large good condition on call (734) 427-0244

*KAYAK STAINLESS steel sink & Kitchen Aid built in dishwasher 248 349 8572

FIREWOOD lot of wood mostly in large pieces you remove 734 595 4686

FREE ALUMINUM SHUTTERS 2 pair 17x82 3 pair 17x66 (248) 258 1975

FREE (300) RECLAIMED BRICK you pick up (248) 865 7743

FREE Rocks (river rocks) bring your own shovel & wheelbarrow 734-968-1850

GREEN BED cap for 1979-80 Ford pickup up or other models 313 531 8846

KITTEN Grey 7 weeks old Female (248) 543 1162

LUMBER 6 & 8 4x4's also 2x4's 313 848 9113

POOL Above ground 24ft 5ft you must move! (248) 549 6621

SCRAP METAL Free 313 946-9113

TRIP/ODT 4000 Walker Call noon 6pm (734) 729 1234

702 Antiques/Collectibles

ANNOUNCING! Michigans Only Exposition and Sale of 20th Century Design

MICHIGAN MODERNISM EXPOSITION

Southfield Civic Center 2800 Evergreen @ 10 1/2 MI (696 to Evergreen exit S)

April 27 & 28 Sat 11-9 Sun 12-5 ART DECO ART NOUVEAU ARTS & CRAFTS 50's 60's and MUCH MORE!

\$100 OFF with ad

ANTIQUA SALE Indian Bas kets Crocks Ironstone glass ware furniture Sat 10 4 16145 Elizabeth Beverly Hills Pierce & 13 Mile

ANTIQUES At McDONNELLS Under New Ownership 19650 W 12 Mile 248 569 0481

Tues Sat 10:55 Sun 12:5 We Sell & Buy French & Mahogany jewelry sterling silver jewelry coins art & stained glass Limited Dealer Space

BEDROOM SET mahogany 5 piece Early Empire Great cond \$3000/best 248 620 1845

DELICIOUS ANTIQUES We make house calls estate and private sales and internet sales Insurance and Estate appraisals. We are also looking to purchase fine China crystal silver oil paintings furniture costume and fine jewelry

Member of ISA 515 S Lafayette Royal Oak Mon Sat 11-5 248 399 2608 Visit our website www.deliciousantiques.com

DINING SET Remwebber Chip table 1930's buffet server table 2 leaves handcarved \$5000 (248) 628-5147

DINING table mahogany Mahogany Phyle with 3 leather chairs 248 476-0199

FREE COLLECTIBLE SHOW Sat Apr 27 10-12 Inside Yvony's Treasures Livonia Mall Sun Auction 12-4

OLD HORSE Drawn Wagon w/ wood/steel wheels \$500 (248) 650 5179

TWO DRESSERS pine with spoon carvings oak with original mirror \$150 each Oak slipper rocker \$50 After 4pm (734) 722 1527

704 Arts & Crafts

SPRING BOUTIQUE Thurs April 25th 10am-5pm Plemon tesse Club 9 Mile between Haggerty/Halstead 248 207 4973

706 Auction Sales

nUGE HOUSEHOLD Sat 6pm 5089 Dixie Waterford

706 Auction Sales

ABSOLUTE AUCTION Sun April 28 Noon to be held at Imlay City Fairgrounds 1/2 mile north of M 53 in Imlay City

Tractors Dozers Skidders Compact Diesels Lawn & Garden Tractors Utility VEHICLES Trailers and Closeouts Much More!! Phone 586 749 8836

E-Mail: gsy@aol.com Jim Calvert Auctioneers

MOORE REAL ESTATE/ESTATE PERSONAL PROPERTY AUCTION 3 Bedroom Brck Home & Household

Auction at 11307 Merriman Rd Livonia Take 1 96 to Merriman Rd exit then S auction is between Plymouth Rd & Joy Rd

Pre Sale Inspection Wed April 24 & Wed May 1 4 6pm Terms on real estate \$5000 deposit in a cashiers check due on sale day Balance in full within 30 days

OWNER Estate of Gerion Moore You can view and print our other auctions from our web site listed below

Braun & Helmer Auction Service (734) 996-9135 (734) 994-6309 www.braunandhelmer.com

NORDMAN AUCTION 10 upright arcade games Sound & Karaoke equipment Deep V Aluminum boat 3 axle Steiger equipment Trailer Lawn equipment Furniture House hold Musical Instruments Com mercial sewing machines

AUCTION 6355 Brendal Rd White Lake MI Wed May 1 @ 11am OWNER Chris & Lon Nordman You can view and print our other auctions from our website listed below

Braun & Helmer Auction Service (734) 996-9135 (734) 994-6309 www.braunandhelmer.com

708 Rummage Sale/ Flea Markets

BIRMINGHAM First United Methodist Church 1559 W Maple between Southfield & Cranbrook Wed May 1st 6-9pm 30% mark up Silent auction & snack bar Thurs May 2nd 10-12pm Fri May 3rd 9-11am \$5/bag

BIRMINGHAM RESALE Brand name & designer clothes for the family Household items Bring in for 50 off purchase of \$20 Mon Fri 10-6 Sat 10-5 123 W Brown St 248 644-7871

BLOOMFIELD HILLS Birmingham Unitarian church rummage sale Woodward at Lone Pine Thursday evening May 2nd 7-9 (silent auction) Friday May 3rd 10-2 p.m Half price sale Something for everyone! Saturday May 4th 9 noon Bag of rummage \$30

BLOOMFIELD Women of Bloomfield Rummage Sale Fri Apr 26th 9-4 Sat Apr 27th 9-12 Noon 12 Cross of Christ Church NW corner of Telegraph and Lone Pine

FARMINGTON HILLS Finnish Cultural Center Semi Annual Rummage Sale Sat 5-8pm Sun 9-12pm SATURDAY 9am-2pm 35200 W 8 Mile Rd (located 1 mile W of Farmington Rd) Refreshments Available Call 248 478 6939

LIVONIA Mom to Mom Sale Sat Apr 27th 9am-2pm Newburgh United Methodist Church 36500 Ann Arbor Tr between Wayne Rd & Newburgh Rd & adjacent pro teen clothes toys and furniture

LIVONIA ST ANDREWS EPISCOPAL CHURCH 16300 Hubbard Rd (1st signal light W of 16 Mile) Sat 9-12 (6 & 6 Mile) Fri Apr 26th 9am-4pm Sat Apr 27th 9-2pm (Bag sale 1-2pm) Plant & Bake Sale

NOVI Church Rummage Sale 4 25 4 27 Sat \$1 bag 44400 10 Mile between Taft/Novi

PLYMOUTH METHODIST Church 45201 N Terminal Wed May 1 9-5 & Thur May 2 9-2 & \$3 bag sale 3-5

ROCHESTER CONGREGATIONAL CHURCH Fri Apr 26th 9am-5pm (Early birds admitted at 8:30am for \$1.00) Sat Apr 27th 9am noon \$2.00 per bag. A price on large items Great bargains in Royal Rummage Room 1315 N Pine St 2 blocks S of Tenken Rd & 1 block W of Rochester Rd

RUMMAGE SALE Sat April 27 9am-3pm Treasures & trinkets No early shoppers Unity of Livonia 28880 Five Mile between Middlebelt & Inkster

SPACE AVAILABLE for Lathrup Village City Wide garage sale/flea market to be held Sat June 1 at City Offices on Southfield Rd For information call (248)559 0904

WESTLAND Huron Valley Lutheran High School 33740 Cowan Rd E off Wayne N of Warren Fri Apr 26 9-4 Sat April 27 9-1 (bag day)

710 Estate Sales

EXCELLENT ESTATE SALE Fri/Sat Apr 26 & 27 10-4 4512 WALDEN DRIVE WEST BLOOMFIELD (N off Walnut Lake Rd W of Franklin Rd)

BEAUTIFUL CONTEMPORARY HOME IRVING AMBETH cream sectional 8 DONGHIA 4 g leafed arm chairs M O M A lounge chairs 2 outstanding brass & glass Elio cabinets PHILLIP LAYVERNE brass cocktail table glass & marble coffee table custom mica side board cream color chaise art work 2 PETER MAX oils TARKAY BROCKA V MONTICENO international sterling flatware for 16

OWNER 10 designer furniture (8 10) Armani Donna Karen Escada Fendi Ungaro Versace plus personal & household items everything is high quality

SEE YOU THERE! EDMUND FRANK & CO LIQUIDATORS & APPRAISERS (313) 869-5555

ANOTHER! 3 Great Sales! By Everything Goes

#1) Fri/Sat April 26-27 10-4 5030 Walbrook Ct N off 14 Mile between Middle belt & Inkster take Ten Hill Rd TRUE ESTATE SALE! Mahogany Grand Piano Knoll & other modern furni ture & accessories Leather marble table & chairs Good artwork 2 bedroom sets Office Great men's & women's designer clothing! Appli ances golf sports jewelry silver china & more!

#2) Fri/Sat April 26-27 10-4 4640 Dow Ridge N off Commerce Rd 2 miles W of Orchard Lake Road PRE DEMLITION SALE Custom kitchen cabinets All Andersen windows & door walls iron pool fence 4 baths w/high end hardware & marble top vanities Jacuzzi High quality furniture Acces sories & rugs All carpet 2 new furnaces & AC systems Deck & dock Electronics Industrial equipment Load of carved Rosewood furniture Desks & tons more!

#3) Fri/Sat April 26-27 10-4 30507 Woodward Ave W side of Woodward S of 13 Mile next to Coney Island STORE LIQUIDATION SALE! Quality furniture Accessories Carved Oriental rugs Carved Rosewood & custom furniture Artwork Electronics Decorative & household items All must go! www.everything goes.com Hotline 248 968 1077

ANOTHER LOADED PACKED JAMMED AND QUALITY ESTATE SALE BY DECORATIVE ANTIQUES

Fri & Sat April 26 & 27 Fri 9-4 Sat 10-4 (9-9:30) 30692 TANGLEWOOD (In Ramblewood Sub which is S off 14 Mile Road 1/2 Mile W of Drake Enter front and go to the 3rd street turn right) also after my sale there is a sub wide sale (Have Fun!)

A SAMPSON PLUS OF THE 3 FLOORS Leather sectional & 3 other couches 2 dining rooms sets 2 kitchen sets breakfast 3 bed room sets 3 display cabinets fab loveseat 2 new baby cribs and baby items Earnes style chair and ottoman pedestals lots of floor and table lamps 5 TV's large mirrors dressers and cabinets elegares fab art work marble coffee table glass desk bar stools 6 modern chairs kitchen set exercise equipment 5 great non sugar stereo fax gular and amp towels sheets and linens a huge amount of great household items outdoor furniture loaded garage with Sears lawnmower gas blowed edger bikes and more loaded kitchen and basement PLUS antiques and collectibles, brand new Amigo 3 wheel electric scooter high end wheel chair Red Wing collectibles Unreal amount of women's clothing shoes purses and gold and costume jewelry partial list and all quality I GIVE THE BEST DEALS - COME ONE COME ALL!

CHRISTY'S ESTATE SALE Royal Oak Thurs Sat Apr 25th 27th 10am-5pm 2405 B Torquay Apt 105 W off Crooks between 14 & Meier 1989 Outlast Clera very clean Bedroom set good furniture dining set collectibles silver set china crystal and more ALL MUST GO! Cash only

ESTATE SALE 40s furniture pictures depression glass jew elry rare buffet opens to dining table kitchen/basement items prosd to sell 4-27 9-4m 4-28 9-3pm 34000 Fountain Blvd Holiday Pk off Wayne btwn Warren & AA Trail

GARDEN CITY Estate/ Garage Antiques/ new Vintage items fishing equipment furniture col lectable magazines/books 31405 Sheridan Sat & Sun 6-3pm

HOUSEHOLD SALES CONDUCTED BY Lilly M. & COMPANY Call Toll Free 1-800-558-8851

LIVONIA April 26 & 27 9-4 12 3 Bedroom outfits couches childrens toys & clothing household tools Quaker Town Sub 16480 Ald rich Ct 6 Mile & Haggerty

LIVONIA 30425 Lyndon between Middlebelt & Mer riman 5 Mile & 96 April 25 26 & 27 Open 9am to 4 30pm

710 Estate Sales

PLYMOUTH ESTATE SALE Liquidating 40+ years worth Fur niture New & used ladies clothes size 14-16 Lots of kitchen misc Yard tools ponc tables washer/dryer refrigerator lots more Fri/Sat April 26 27 10-4m 740 McKinley E of Sheldon S of Ann Arbor Rd

SOUTHFIELD Estate Sale Fri Sat 10am-4pm Plenty of tools records computer audio & video equipment Morris chair books riding lawn mower newer snow blower 25270 Way cross W of Beech/N off 10 Mile

W BLOOMFIELD Estate Sale 7373 Cold Spring Ln W of Ink ster N off 14 Mile Sat 4-27 9-5 Sun 4-28 9-4 Collectibles Household Old Books & Paper Power & Hand Tools Photo Accessories w/older spotlights Old Military Uniforms & items Furniture 19th c Rope Bed Older Prints 16 5 hp Gravelly Lawn Tractor 28 Ladder COM MERCIAL Lead Blowers Drill Press Paper Cutter Craftsman 12' Table Saw Old Records Office Supplies Washer/Dryer Freezer Wood Cowboy & Rocking Horse Trim Lumber lots more Our s at 8am No early sales or previews Sale by CT's Treasure Haven

BEVERLY HILLS Good Stuff Satel 16934 Georgina near 13 Mile & Pierce Apr 26 27 10-4 Some quilting

BEVERLY HILLS Thurs 9-3 7400 Birchwood 2 bks S of 14 E of Southfield Micro wave roaster lawn chairs dishes many household items

BIRMINGHAM Best Sale of the Season! Folk art furniture am more! Apr 25 27 10am-5pm 1185 Lake Park Drive Off Maple W Woodward

BIRMINGHAM Moving to the mountains can't take much of these prime furniture (sofa chairs tables Color TV & more) Adult clothes art work oriental decor + more Fri Apr 26 9-4 Sat Apr 27 9-12 655 Lake view Oak & Old Woodward

BLOOMFIELD TWP Sat only 9am-4pm 6370 W Surrey Foxcroft Sub Luggage clothing stuff 1156 W 2nd Arden Trail between Sheldon & Ann Arbor

PLYMOUTH Annual Westbnar 11 Sub Sale Sat Apr 27 9-3 McClumpha & Ann Arbor Rd Rain or Shine

PLYMOUTH Apr 25 28th 9-4 9285 Mayflower Dr W of Sheldon S of Ann Arbor Rd Lots of baby & kids toys & clothes

PLYMOUTH Garage/Moving Sale Multi family Sat Apr 27 10-4pm Furniture adult clothing drapes misc good stuff 1156 W 2nd Arden Trail between Sheldon & Ann Arbor

PLYMOUTH Sat Apr 27 9-4 45039 Gov Bradford off Canton Cir between Ann Arbor Rd & Ann Arbor Tr Tools furniture household goods

PLYMOUTH Sat Only 9am 5pm 40355 Gilbert Ann Arbor Trail & Haggerty Baby items clothes (Gap & Gymboree)

PLYMOUTH Sat 8am-3pm 821 Beech Ct off Sheldon Hwy Sale dinette chair pew lammower baby furniture

PLYMOUTH 2 House 7 fam ily 1979 799 Auburn E of Sheldon N of Farmer Apr 26 27 Antiques kids Dooney name brands & misc

REDFORD TWP Garden tractor Rear tire rottilator parts washer lawn equipment tools collector plates house items Apr 26 28 9-3 9289 Manor Crescent

ROCHESTER HILLS Large estate sale 20 families April 27 10-5pm Walton Woods Sr Community 3250 Walton Blvd E of Adams Everyone welcome

ROCHESTER HILLS Move in sale Sat April 27 9am-4pm 326 Shagbark off Walton btwn Walton & Old Perch Leather sections rugs dryer bedroom suite & more

ROCHESTER HILLS Tons Of baby clothes furniture baby stear master clothes & shoes Much More! Apr 25 26 9-3 899 Dakota Dr N Off Avon Btwn Rochester Rd & John R

ROCHESTER HILLS Whis peng Willows Sub Sale Sat Apr 27 8-5 S of Hamlin W of Livernois Look for balloons Some homes open Thurs Fri

ROMULUS Huge crafts book & garage sale! April 26 28 From 8am to 3pm at 11560 Inkster Rd Between Goddard and Northline

ROMULUS 26th 27th & 28th 11560 Inkster Rd S/Goddard 82 FLH Harley 65 Mustang Coupe 360 Chevy motor built 4 over new electric chain fall Mack snap on tools & books boat trailer thousands of old books glassware & china 85 Chevy 3/4 ton pick up diesel 9 horse gas power wash small utility trailer & much more!

Southfield Big Apr 25-26 9-6 Clothes women & men plus size good cond Furniture Sports memorabilia 30770 Red Maple S of 13 E/Evergreen

TROY Apr 25 27 9am 5pm Infant to Size 5 toys baby & household items & more! 2865 Majestic W Of Dequindre Blvd 16 & 17 Mile rds

TROY GARAGE sale 237 Carter Ave 2 blocks N of Wat ties turn left on Carter Ave off Livernois 10am 5pm Apr 27 28 Camping household items & more

TROY Multi family sale Fri 9-4 Sat 9 noon 56 Siskoford S of 18 Mile E of Livernois off Glenshire Furniture & many new & "hardly used items"

W BLOOMFIELD Multi family Bikes exercise equipment lawn mower children items Henbert Rd Loohaven & Greer Thurs Sat 9am

W BLOOMFIELD multi family Lots of good stuff! 3515 Wimbberly Ct S off Long Lake Rd between Orchard Lake & Mid diebelt Thurs Sat 9-5

W BLOOMFIELD Saturday April 27th 9-4 2 family huge sale GE washer/dryer exercise equipment household items great art women's teens chil dren clothes and more 5553 W/ing West off Farmington & Maple

W BLOOMFIELD 1st Annual Convntion Sub Sale 15 sepa rate homes located between Lone Pine & Long Lake off Shore Crest & Apple Valley Fri & Sat 9-5 Apr 26th & 27th

W BLOOMFIELD 6360 Richard Run Potomac Town Condos Maple and Farm ington Furniture dining room table light fixtures much more April 26th & 27th 9-4

LIVONIA Whole house appli ances furniture tools etc 18424 Myron 3 blocks W of Farmington S of 7 Mile Sun 4-28 11 AM 6PM

LIVONIA 16860 Hubbard Farmington & 6 Mile Fri & Sat Apr 26 & 27 9-4 Antique sofabed 3 entry doors 2 wood & 1 steel w/beveled glass elec tric stove girls clothes size 7 teen misc household

MADISON HTS GREAT LAKES DEPRESSION GLASS CLUB 28th ANNUAL SHOW & SALE Sat April 27 10-5 Sun April 28 11-4 Glass identification booth and expert glass repair available Location United Food & Comm Workers Union Bldg 876 Horace Brown Dr W of John R E of Stephenson Hwy 13 Mile R & 175 S4 donation For more info call (586) 739-4290

NORTHVILLE OLD furniture & china tools household items 232 Center St April 27 9am to 5pm

NORTHVILLE SUB Sale Hills of Crestwood 6 Mile & Beck Sat Apr 27 9-2

711 Garage Sales

LIVONIA 16860 Hubbard Farmington & 6 Mile Fri & Sat Apr 26 & 27 9-4 Antique sofabed 3 entry doors 2 wood & 1 steel w/beveled glass elec tric stove girls clothes size 7 teen misc household

MADISON HTS GREAT LAKES DEPRESSION GLASS CLUB 28th ANNUAL SHOW & SALE Sat April 27 10-5 Sun April 28 11-4 Glass identification booth and expert glass repair available Location United Food & Comm Workers Union Bldg 876 Horace Brown Dr W of John R E of Stephenson Hwy 13 Mile R & 175 S4 donation For more info call (586) 739-4290

NORTHVILLE OLD furniture & china tools household items 232 Center St April 27 9am to 5pm

NORTHVILLE SUB Sale Hills of Crestwood 6 Mile & Beck Sat Apr 27 9-2

NOVI multi family garage sale Fri April 26 9-5pm 583 Del mont Dr NE 10 Mile & Wixom) Refrigerator gas stove household books software Star Wars toys kitchen sink bed frame etc

NOVI Sat April 27 9am 2pm 40880 Kingsley Lane Haverrhill 14 Mile W of M5 Toys kids clothes dishwasher table saw radial arm saw more

OAKLAND Multi Family! Apr 25&26 9am 5pm Partial pro ceeds go to childrens charities 415 & 1170 W Piedmore W of Rochester Rd

PLYMOUTH Annual Westbnar 11 Sub Sale Sat Apr 27 9-3 McClumpha & Ann Arbor Rd Rain or Shine

PLYMOUTH Apr 25 28th 9-4 9285 Mayflower Dr W of Sheldon S of Ann Arbor Rd Lots of baby & kids toys & clothes

PLYMOUTH Garage/Moving Sale Multi family Sat Apr 27 10-4pm Furniture adult clothing drapes misc good stuff 1156 W 2nd Arden Trail between Sheldon & Ann Arbor

PLYMOUTH Sat Apr 27 9-4 45039 Gov Bradford off Canton Cir between Ann Arbor Rd & Ann Arbor Tr Tools furniture household goods

PLYMOUTH Sat Only 9am 5pm 40355 Gilbert Ann Arbor Trail & Haggerty Baby items clothes (Gap & Gymboree)

PLYMOUTH Sat 8am-3pm 821 Beech Ct off Sheldon Hwy Sale dinette chair pew lammower baby furniture

PLYMOUTH 2 House 7 fam ily 1979 799 Auburn E of Sheldon N of Farmer Apr 26 27 Antiques kids Dooney name brands & misc

REDFORD TWP Garden tractor Rear tire rottilator parts washer lawn equipment tools collector plates house items Apr 26 28 9-3 9289 Manor Crescent

ROCHESTER HILLS Large estate sale 20 families April 27 10-5pm Walton Woods Sr Community 3250 Walton Blvd E of Adams Everyone welcome

ROCHESTER HILLS Move in sale Sat April 27 9am-4pm 326 Shagbark off Walton btwn Walton & Old Perch Leather sections rugs dryer bedroom suite & more

ROCHESTER HILLS Tons Of baby clothes furniture baby stear master clothes & shoes Much More! Apr 25 26 9-3 899 Dakota Dr N Off Avon Btwn Rochester Rd & John R

ROCHESTER HILLS Whis peng Willows Sub Sale Sat Apr 27 8-5 S of Hamlin W of Livernois Look for balloons Some homes open Thurs Fri

ROMULUS Huge crafts book & garage sale! April 26 28 From 8am to 3pm at 11560 Inkster Rd Between Goddard and Northline

ROMULUS 26th 27th & 28th 11560 Inkster Rd S/Goddard 82 FLH Harley 65 Mustang Coupe 360 Chevy motor built 4 over new electric chain fall Mack snap on tools & books boat trailer thousands of old books glassware & china 85 Chevy 3/4 ton pick up diesel 9 horse gas power wash small utility trailer & much more!

Southfield Big Apr 25-26 9-6 Clothes women & men plus size good cond Furniture Sports memorabilia 30770 Red Maple S of 13 E/Evergreen

TROY Apr 25 27 9am 5pm Infant to Size 5 toys baby & household items & more! 2865 Majestic W Of Dequindre Blvd 16 & 17 Mile rds

TROY GARAGE sale 237 Carter Ave 2 blocks N of Wat ties turn left on Carter Ave off Livernois 10am 5pm Apr 27 28 Camping household items & more

TROY Multi family sale Fri 9-4 Sat 9 noon 56 Siskoford S of 18 Mile E of Livernois off Glenshire Furniture & many new & "hardly used items"

W BLOOMFIELD Multi family Bikes exercise equipment lawn mower children items Henbert Rd Loohaven & Greer Thurs Sat 9am

W BLOOMFIELD multi family Lots of good stuff! 3515 Wimbberly Ct S off Long Lake Rd between Orchard Lake & Mid diebelt Thurs Sat 9-5

W BLOOMFIELD Saturday April 27th 9-4 2 family huge sale GE washer/dryer exercise equipment household items great art women's teens chil dren clothes and more 5553 W/ing West off Farmington & Maple

W BLOOMFIELD 1st Annual Convntion Sub Sale 15 sepa rate homes located between Lone Pine & Long Lake off Shore Crest & Apple Valley Fri & Sat 9-5 Apr 26th & 27th

W BLOOMFIELD 6360 Richard Run Potomac Town Condos Maple and Farm ington Furniture dining room table light fixtures much more April 26th & 27th 9-4

711 Garage Sales

WESTLAND April 25 26 27 10am 5pm Ladies clothing crafts 523 Byfield (Cherry Hill & Wildwood)

WESTLAND April 26 28 9-4 30 years of collecting sporting goods glassware boycout uni forms collector mugs baskets wheel processor car parts dishes jewelry something for everyone! 35942 Somerset (Cherry Hill & Wayne)

CANTON King cherry bedroom set oak dining table & 6 chairs 2 leather sofas 734-981 1614 or 313 383 6966

CANTON queen bed double beignique set w/ mattress stand market umbrella plants misc Fri 9-3 Sat 14 4010 Pond Run Ct S of Geeddes E of Beck

CLARKSTON Moving Fri Sun 9 6

AUTOMOTIVE

www.observerandeccentric.com

748 Lawn Garden & Snow Equipment

MTD 8/26 electric start snow blower 6 forward 2 reverse speeds Like new \$400 After 4pm (734) 722 1527

751 Musical Instruments

RENT A PIANO \$25/mo! This week's special free delivery! Call for details Michigan Piano (248)548 2200 www.mipiano.com

784 Dogs

GERMAN WALKHOUND male special disposition trained neutered all shots good with kids (248) 203 0082

802 Boats/Motors

BAYLINER 28'4" 1987 a/c 10 ft beam all equipment \$14 900/best (734) 397 0645

802 Boats/Motors

CHAPARRAL 1830 SS Bow Rider (1998) 4 Mercruiser 90 hrs mint cond stored indoors year round includes trailer \$15 500/best (248) 360 6552

750 Miscellaneous For Sale

CENTRAL AIR CONDITIONING brand new in box janitor #10 unit inside A/C coil & outdoor unit for \$595 248 614 9130

751 Musical Instruments

WIN FREE TICKETS TO MEADOW BROOK THEATRE'S PRODUCTION OF THE EXCITING ROCK MUSICAL 'GODSPELL!'

802 Boats/Motors

ACHILIS 1993 8.6 inflatable with 6 hp Merc with extras Like new \$1600 313 274-7151

802 Boats/Motors

CANOE & KAYAK SWAP Apr 27 & 28 at Canoe Sports in Ann Arbor Call 734 663 9515 for details

802 Boats/Motors

CREST PONTOON BOAT 25ft Esc cond new 9.9 4 stroke mercury outboard power tilt Bernier top 3 x 8 swim platform storage box for battery fuel life vest Built in stereo \$3 850 248-393 1468

800's Autos/RVs

- 800 Airplanes
802 Boats/Motors
802 Boat Parts
804 Boat Docks/Marinas
805 Boat/Vehicle Storage
806 Insurance Motor
807 Motorcycles/Minibikes/Go Karts
808 Motorcycles Parts & Service
809 Off Road Vehicles
810 Recreational Vehicles
811 Snowmobiles
812 Campers/Motor Homes/Trailers
814 Construction Heavy Equipment
815 Auto Misc
816 Auto/Tire Parts & Service
817 Auto Rentals/Leasing
818 Auto Financing
819 Autos Wanted
820 Junk Cars Wanted
822 Trucks For Sale
824 Mini Vans
826 Vans
828 4 Wheel Drive
829 Sport Utility
830 Sports & Imported Cars
832 Antique/Classic Collector Cars
834 Acura
836 Buick
838 Cadillac
840 Chevrolet
842 Chrysler
844 Dodge
846 Eagle
848 Ford
850 Geo
852 Honda
854 Lexus
856 Lincoln
858 Mazda
860 Mercury
861 Mitsubishi
862 Nissan
864 Oldsmobile
866 Plymouth
868 Pontiac
870 Saturn
872 Toyota
874 Volkswagen
876 Autos Over \$2000
878 Autos Under \$2000

1-800-579-SELL

802 Boats/Motors

SEADOO 1997 GTX 2 very nice machines green & white 80 hrs Tandem trailer & covers \$8700 (248) 476 7830

802 Boats/Motors

SEARAY 22.5 WEEKENDER 1979) 350 Merc new canvas good cond extras \$4900/best (734) 453 4792

751 Musical Instruments

BABY GRAND PIANO Samick 1987 solid oak like new \$6300/best (248) 628 2200

752 Sporting Goods

GOLF BAG & (2) woods & (6) irons good for starter all \$100 (313) 702-4845

802 Boats/Motors

AEROCRAFT 1986 18ft bow rider 4.3L I/O Great Cond w/trailer Many extras Must sell \$3 995 (810) 240 1298

802 Boats/Motors

CHAPARRAL 198CXL 1985 Cuddy 170 Mercruiser I/O head trailer exc cond \$3900 After 6pm 248 681 1171

802 Boats/Motors

FOUR WINNS 1992 190 Horizon open bow 5.0L exceptionally well maintained \$7 995 (517) 548 9047

751 Musical Instruments

KAWAI & Yamaha Pianos Wanted Most any cond no dealers 248 343 3623

752 Sporting Goods

GOLF CARS Easy Go & Club Car (734) 453-2063

802 Boats/Motors

MASTERCRAFT 1994 excellent condition with trailer 500 hours \$19 000/ or best offer (734) 449 8315

802 Boats/Motors

PLAYBOY 1989 Pontoon Runs well \$1500 or best offer 248-738-5880 or 248-398-8666

802 Boats/Motors

SEA DOO 1999 SPX Jet Ski with Shoreland trailer Excellent condition \$3500 (734) 981 8030

751 Musical Instruments

PIANO Kohler Campbell walnut spinet tuned Jan 02 Asking \$850/best offer 734 455 8162

752 Sporting Goods

POOL TABLE 8 Connelly slate top like new New \$2300 \$800 firm SOLD

802 Boats/Motors

SEA DOO/ Bombardier 1999 Challenger 1800 Jet Boat Mint \$13 900/best 248 647 6529

802 Boats/Motors

SEA DOO 2000 Challenger 180hp, \$1 000 in extras like new! \$12 500 734-722 8514

802 Boats/Motors

SEARAY 1990 310 Sundancer twin 260 L hrs Bristol cond \$59 900/best 248-656 2983

Michigan Humane Society ADOPT-A-PET This Week's Featured Pet Rufus is a ten month old Rottweiler male who was found stray and brought to the shelter to find a home He is very handsome with lean yet muscular physique covered with copper and black fur He is very sweet and likes to play bite therefore he is not recommended for a home with children under ten years of age Since he has lots of energy he will need to find an owner who can give him regular playtime and walks In addition he is a candidate for obedience training so that he can become a well mannered mature pooch Since he is already neutered and up to date on his shots he is able to go home with you today! To welcome Rufus home, visit the Michigan Humane Society Westland Shelter, (734) 721-7300

HOME & SERVICE GUIDE

CAPTURE The Spirit of Spring To Schedule a Home & Service Directory ad Call: 1-800-579-SELL • Fax: 734-953-2232

011 Asphalt/Blacktopping DJS BLACKTOP DRIVEWAYS • Paving • Patching • Seal Coating Free Est 800 724 8920 734 397 0811

031 Building/Remodeling SAVE MONEY! Deal Direct 30 yrs exp Brassfield Construction Co New Cons Remodeling • Additions • Kitchens • Baths • Garages Design & Financing Lic/Ins 248 737 3376

048 Chimney Building/Clean/Repr NORTHVILLE CONSTRUCTION Chimney & masonry repair Lic & Ins Visa & Mastercard Sen or d consort (734) 878 6600

073 Excavating/Backhoe SEWER & WATER LINES Concrete Removal Septic Install on Excavating Lic Ins Cal Matt (734) 417 0708

103 Hauling/Clean Up A1 HAULING Moving Scrap metal cleaning basements garages stores etc Lowest prices in town Quick service Free est Wayne/Oakland Counties Central location 547 2764 or 558 8138

121 Landscaping MARK'S LANDSCAPING & LAWN SERVICE Tree service spring cleanup construction clean up & haul away We do everything We do it right Licensed & insured Free estimates (248) 975 6014

138 Moving/Storage EXPERT MOVING COMPANY 15 Yrs Experience Available 7 days/week FREE Est (734) 981 9962

148 Plumbing (248) 471-2600 Plumbing & Sewer Cleanng Repairs & Alterations

164 Roofing 248-471-2600 New & repair also rubber roofing carpentry insurance work

012 Asphalt/Sealcoating ALL SEALS seal coating Conv/ Res/ind rubberized crack fill striping asphalt patching 248 449 5551 Free estimate

022 Basement Waterproofing WALKER WATERPROOFING Small leaks to entire basement • Quality • Affordable • Lic • Ins (734) 675 1246

055 Concrete CREATIVE HOME BUILDING & REMODELING Lic & Ins • New construction • Remodeling • Additions • Garages • Custom Decks • Finished Basements • Kitchens • Baths • Roofing & Siding Frame crew for hire 734-368-4237

086 Floor Service LIVONIA FLOORS SPRING SPECIAL Textured plush carpet 24 colors 8 lb padding installed \$22/2sq ft Hardwood tile linoleum laminates sales & installation Ins claims Free est (734) 458-2401

106 Home Improvement AFFORDABLE HOME REPAIRS Save money by using America's largest handyman service Insured Bonded Licensed HOUSE DOCTORS 734 782 5006

123 Lawn, Garden Maint/Service ABOUT BEST LANDSCAPING LAWN SRV • Sod • Flower Beds • Garden Walls • Bushes Trees • Decks Pavers 313 433 3487

142 Painting/Decorating/Paperhangers BEAT ANY WRITTEN ESTIMATE 248-476-0011 313-835-8810 PAINTING/PAPERING Plastering Repairs Wallwashng Vsa & MC AMEX

153 Pressure Power Washing A & A powerwashing services Res & Comm cleaning painting staining & all with a smile! Call (734) 285 1940

177 Siding • Family Owned • Responsible REDFORD ALUMINUM PROCD 734-464-1545 / 734-953 0399

029 Brick, Block & Cement AAA BRICK CO • Porches Chimneys Steps & All Masonry Work Lic & Ins Call Jeff (734) 432 7878

041 Carpentry CREATIVE HOME BUILDING & REMODELING Lic & Ins • New Construction • Remodeling • Additions • Garages • Custom Decks • Finished Basements • Kitchens • Baths • Roofing & Siding Frame crew for hire 734-368-4237

060 Decks/Patios/Sunrooms AFFORDABLE CUSTOM DECK Wolmanized or Cedar Lic/Ins Free Est 18 Yrs Exp 734 281 1614 248 442 2744

092 Garage Door Repair GARAGE DOOR Springs & door openers repaired/replaced Avail Sun 248 640 6298 Cell

108 Housecleaning CLEANING LADY dependable thorough 4 years exp own transportation references Call Anytime (313) 365-4237

121 Landscaping AFFORDABLE LAWN CARE Call G&G Landscaping today for early spring rates, 10+ yrs exp Free Est (248) 321 8920

142 Painting/Decorating/Paperhangers BEAT ANY WRITTEN ESTIMATE 248-476-0011 313-835-8810 PAINTING/PAPERING Plastering Repairs Wallwashng Vsa & MC AMEX

162 Remodeling JIM SEGHI RENOVATIONS Kitchens baths rec rooms ceramic tile additions Design Service Quality workmanship Free Estimates (248) 437 2454

179 Site Development SEWER & WATER LINES Concrete Removal Septic Installation Excavating Lic Ins Call Matt (734) 417 0708

029 Brick, Block & Cement AAA BRICK CO • Porches Chimneys Steps & All Masonry Work Lic & Ins Call Jeff (734) 432 7878

041 Carpentry CREATIVE HOME BUILDING & REMODELING Lic & Ins • New Construction • Remodeling • Additions • Garages • Custom Decks • Finished Basements • Kitchens • Baths • Roofing & Siding Frame crew for hire 734-368-4237

060 Decks/Patios/Sunrooms AFFORDABLE CUSTOM DECK Wolmanized or Cedar Lic/Ins Free Est 18 Yrs Exp 734 281 1614 248 442 2744

092 Garage Door Repair GARAGE DOOR Springs & door openers repaired/replaced Avail Sun 248 640 6298 Cell

106 Home Improvement AFFORDABLE HOME REPAIRS Save money by using America's largest handyman service Insured Bonded Licensed HOUSE DOCTORS 734 782 5006

121 Landscaping AFFORDABLE LAWN CARE Call G&G Landscaping today for early spring rates, 10+ yrs exp Free Est (248) 321 8920

142 Painting/Decorating/Paperhangers BEAT ANY WRITTEN ESTIMATE 248-476-0011 313-835-8810 PAINTING/PAPERING Plastering Repairs Wallwashng Vsa & MC AMEX

162 Remodeling JIM SEGHI RENOVATIONS Kitchens baths rec rooms ceramic tile additions Design Service Quality workmanship Free Estimates (248) 437 2454

179 Site Development SEWER & WATER LINES Concrete Removal Septic Installation Excavating Lic Ins Call Matt (734) 417 0708

029 Brick, Block & Cement AAA BRICK CO • Small jobs welcome Tuck pointing Brick Repair Insured Q 248 478 7949

041 Carpentry ALL REPAIRS INSTALLATIONS AND REMODELING 20% spring discount Lic & Ins (734) 454-0776

065 Doors/Service GARAGE DOOR & OPENER Repair Sales Installation Lic & Ins 30yrs exp Free Est 734 421 9545

100 Gutters CLEANING SCREENING REPAIRS (248) 471-2600

106 Home Improvement AFFORDABLE HOME REPAIRS Save money by using America's largest handyman service Insured Bonded Licensed HOUSE DOCTORS 734 782 5006

121 Landscaping AFFORDABLE LAWN CARE Call G&G Landscaping today for early spring rates, 10+ yrs exp Free Est (248) 321 8920

142 Painting/Decorating/Paperhangers BEAT ANY WRITTEN ESTIMATE 248-476-0011 313-835-8810 PAINTING/PAPERING Plastering Repairs Wallwashng Vsa & MC AMEX

162 Remodeling JIM SEGHI RENOVATIONS Kitchens baths rec rooms ceramic tile additions Design Service Quality workmanship Free Estimates (248) 437 2454

179 Site Development SEWER & WATER LINES Concrete Removal Septic Installation Excavating Lic Ins Call Matt (734) 417 0708

029 Brick, Block & Cement AAA BRICK CO • Small jobs welcome Tuck pointing Brick Repair Insured Q 248 478 7949

041 Carpentry ALL REPAIRS INSTALLATIONS AND REMODELING 20% spring discount Lic & Ins (734) 454-0776

065 Doors/Service GARAGE DOOR & OPENER Repair Sales Installation Lic & Ins 30yrs exp Free Est 734 421 9545

100 Gutters CLEANING SCREENING REPAIRS (248) 471-2600

106 Home Improvement AFFORDABLE HOME REPAIRS Save money by using America's largest handyman service Insured Bonded Licensed HOUSE DOCTORS 734 782 5006

121 Landscaping AFFORDABLE LAWN CARE Call G&G Landscaping today for early spring rates, 10+ yrs exp Free Est (248) 321 8920

142 Painting/Decorating/Paperhangers BEAT ANY WRITTEN ESTIMATE 248-476-0011 313-835-8810 PAINTING/PAPERING Plastering Repairs Wallwashng Vsa & MC AMEX

162 Remodeling JIM SEGHI RENOVATIONS Kitchens baths rec rooms ceramic tile additions Design Service Quality workmanship Free Estimates (248) 437 2454

179 Site Development SEWER & WATER LINES Concrete Removal Septic Installation Excavating Lic Ins Call Matt (734) 417 0708

029 Brick, Block & Cement AAA BRICK CO • Small jobs welcome Tuck pointing Brick Repair Insured Q 248 478 7949

041 Carpentry ALL REPAIRS INSTALLATIONS AND REMODELING 20% spring discount Lic & Ins (734) 454-0776

065 Doors/Service GARAGE DOOR & OPENER Repair Sales Installation Lic & Ins 30yrs exp Free Est 734 421 9545

100 Gutters CLEANING SCREENING REPAIRS (248) 471-2600

106 Home Improvement AFFORDABLE HOME REPAIRS Save money by using America's largest handyman service Insured Bonded Licensed HOUSE DOCTORS 734 782 5006

121 Landscaping AFFORDABLE LAWN CARE Call G&G Landscaping today for early spring rates, 10+ yrs exp Free Est (248) 321 8920

142 Painting/Decorating/Paperhangers BEAT ANY WRITTEN ESTIMATE 248-476-0011 313-835-8810 PAINTING/PAPERING Plastering Repairs Wallwashng Vsa & MC AMEX

162 Remodeling JIM SEGHI RENOVATIONS Kitchens baths rec rooms ceramic tile additions Design Service Quality workmanship Free Estimates (248) 437 2454

179 Site Development SEWER & WATER LINES Concrete Removal Septic Installation Excavating Lic Ins Call Matt (734) 417 0708

029 Brick, Block & Cement AAA BRICK CO • Small jobs welcome Tuck pointing Brick Repair Insured Q 248 478 7949

041 Carpentry ALL REPAIRS INSTALLATIONS AND REMODELING 20% spring discount Lic & Ins (734) 454-0776

065 Doors/Service GARAGE DOOR & OPENER Repair Sales Installation Lic & Ins 30yrs exp Free Est 734 421 9545

100 Gutters CLEANING SCREENING REPAIRS (248) 471-2600

106 Home Improvement AFFORDABLE HOME REPAIRS Save money by using America's largest handyman service Insured Bonded Licensed HOUSE DOCTORS 734 782 5006

121 Landscaping AFFORDABLE LAWN CARE Call G&G Landscaping today for early spring rates, 10+ yrs exp Free Est (248) 321 8920

142 Painting/Decorating/Paperhangers BEAT ANY WRITTEN ESTIMATE 248-476-0011 313-835-8810 PAINTING/PAPERING Plastering Repairs Wallwashng Vsa & MC AMEX

162 Remodeling JIM SEGHI RENOVATIONS Kitchens baths rec rooms ceramic tile additions Design Service Quality workmanship Free Estimates (248) 437 2454

179 Site Development SEWER & WATER LINES Concrete Removal Septic Installation Excavating Lic Ins Call Matt (734) 417 0708

029 Brick, Block & Cement AAA BRICK CO • Small jobs welcome Tuck pointing Brick Repair Insured Q 248 478 7949

041 Carpentry ALL REPAIRS INSTALLATIONS AND REMODELING 20% spring discount Lic & Ins (734) 454-0776

065 Doors/Service GARAGE DOOR & OPENER Repair Sales Installation Lic & Ins 30yrs exp Free Est 734 421 9545

100 Gutters CLEANING SCREENING REPAIRS (248) 471-2600

106 Home Improvement AFFORDABLE HOME REPAIRS Save money by using America's largest handyman service Insured Bonded Licensed HOUSE DOCTORS 734 782 5006

121 Landscaping AFFORDABLE LAWN CARE Call G&G Landscaping today for early spring rates, 10+ yrs exp Free Est (248) 321 8920

142 Painting/Decorating/Paperhangers BEAT ANY WRITTEN ESTIMATE 248-476-0011 313-835-8810 PAINTING/PAPERING Plastering Repairs Wallwashng Vsa & MC AMEX

162 Remodeling JIM SEGHI RENOVATIONS Kitchens baths rec rooms ceramic tile additions Design Service Quality workmanship Free Estimates (248) 437 2454

179 Site Development SEWER & WATER LINES Concrete Removal Septic Installation Excavating Lic Ins Call Matt (734) 417 0708

029 Brick, Block & Cement AAA BRICK CO • Small jobs welcome Tuck pointing Brick Repair Insured Q 248 478 7949

041 Carpentry ALL REPAIRS INSTALLATIONS AND REMODELING 20% spring discount Lic & Ins (734) 454-0776

065 Doors/Service GARAGE DOOR & OPENER Repair Sales Installation Lic & Ins 30yrs exp Free Est 734 421 9545

100 Gutters CLEANING SCREENING REPAIRS (248) 471-2600

106 Home Improvement AFFORDABLE HOME REPAIRS Save money by using America's largest handyman service Insured Bonded Licensed HOUSE DOCTORS 734 782 5006

121 Landscaping AFFORDABLE LAWN CARE Call G&G Landscaping today for early spring rates, 10+ yrs exp Free Est (248) 321 8920

142 Painting/Decorating/Paperhangers BEAT ANY WRITTEN ESTIMATE 248-476-0011 313-835-8810 PAINTING/PAPERING Plastering Repairs Wallwashng Vsa & MC AMEX

162 Remodeling JIM SEGHI RENOVATIONS Kitchens baths rec rooms ceramic tile additions Design Service Quality workmanship Free Estimates (248) 437 2454

179 Site Development SEWER & WATER LINES Concrete Removal Septic Installation Excavating Lic Ins Call Matt (734) 417 0708

029 Brick, Block & Cement AAA BRICK CO • Small jobs welcome Tuck pointing Brick Repair Insured Q 248 478 7949

041 Carpentry ALL REPAIRS INSTALLATIONS AND REMODELING 20% spring discount Lic & Ins (734) 454-0776

065 Doors/Service GARAGE DOOR & OPENER Repair Sales Installation Lic & Ins 30yrs exp Free Est 734 421 9545

100 Gutters CLEANING SCREENING REPAIRS (248) 471-2600

106 Home Improvement AFFORDABLE HOME REPAIRS Save money by using America's largest handyman service Insured Bonded Licensed HOUSE DOCTORS 734 782 5006

121 Landscaping AFFORDABLE LAWN CARE Call G&G Landscaping today for early spring rates, 10+ yrs exp Free Est (248) 321 8920

142 Painting/Decorating/Paperhangers BEAT ANY WRITTEN ESTIMATE 248-476-0011 313-835-8810 PAINTING/PAPERING Plastering Repairs Wallwashng Vsa & MC AMEX

162 Remodeling JIM SEGHI RENOVATIONS Kitchens baths rec rooms ceramic tile additions Design Service Quality workmanship Free Estimates (248) 437 2454

179 Site Development SEWER & WATER LINES Concrete Removal Septic Installation Excavating Lic Ins Call Matt (734) 417 0708

029 Brick, Block & Cement AAA BRICK CO • Small jobs welcome Tuck pointing Brick Repair Insured Q 248 478 7949

041 Carpentry ALL

AUTOMOTIVE

www.observerandeccentric.com

All Ads Run Online FREE! A Value Of Up To \$87.00

This Classification Continued from Page 6G.

807 Motorcycles/Mopeds/Go-Karts

HARLEY 1996 883 Huggler 325 miles black \$3600 extras \$8750 best Trade 248-644-3100
HARLEY 1998 Road King Low miles chrome \$16,500/best HARLEY 1997 Heritage \$15,500/best (734) 762-7996
HARLEY 1998 Road King Low miles chrome \$16,500/best HARLEY 1997 Heritage \$15,500/best (734) 762-7996
HARLEY 1998 Soft Tail custom custom paint & chrome exc cond \$16,500 (734) 813-8187
HARLEY SPORTGLIDE FXRT 1983 Last of the shovelheads 2500 miles after rebuild \$85 heads cases & carburetor Crane camshaft full hard bags windshield you don't see many of these Nice bike \$8000/best Days 313 779-0069 Evenings 734-427-3449
HARLEY 1991 SPORTSTER 1200XLH extras Chromed out \$6250 (248) 684 1895
HARLEY 2000 1200 Sportster Custom under 600 mi \$8900/best (248) 641 9195
HARLEY 1200 Sportster(2000) red extra chrome saddlebags 60 miles \$9500 734-591 3522
HARLEY 1987 Sportster 20K \$4000 Call (248) 960 4243
HARLEY SPORTSTER CUSTOM 2001 1200 cc 4 700 miles Concord Purple and Diamond los perfect cond Must Sell! \$8000 (734) 518-5443
HONDA CB 250 Night Hawk 1995 like new low mileage \$1890 (248) 851 8085
HONDA 19/4 750CC 12 000 mles needs work clean \$600 (248) 797 6014
HONDA 1984 Goldwing GL 1200 excellent condition 31K miles extras new tires/battery \$4000/best 248 851 6797
HONDA 2000 Shadow 600cc silver 6K miles 3 year warranty garaged \$4300 734 340-4363
HONDA 2002 Shadow Deluxe 600cc black exc cond \$4 650 (734) 451 0759
HONDA 2001 SHADOW 750 250 miles Better than new \$4500 (248) 478 0066
HONDA SHADOW 1993 only 8000 miles \$1999 248 528 9239
HONDA SHADOW 1999 VT800 brand new 95 actual miles best offer over \$4495 (313) 255-4879
HONDA 1982 Silverwing Interstate 1750 New tires \$1 300 After 5pm 734-522 9454
HONDA 1997 VTX 600cc 2500 mi Stock windshield back rest \$3000/best 734-453-9133
KAWASAKI 1992 Ninja 600 red/black 17k mi many new parts \$2400/best 734 867 3718
SUZUKI BANDIT 2000 GSF 600 2500 mi Stock inside yr round exc shape \$4300 734-449-0875
SUZUKI 1998 600 GSX red/black low miles exc condition \$4500/best 248 552 9161
SUZUKI 2000 GZ250 900 mi Exc cond Windshield Great new rider b.k.e \$2250 734-542 0943
YAMAHA FZR 600 1998 1200 miles \$4200/best Must sell (734) 867 4250
YAMAHA 1983 Venture Royale 30K mi new seat paint & tires good cond \$2500 734-718-0062
YAMAHA 750 Virago very clean 6000 miles \$3500 734 422 7804
YAMAHA 2001 WR426 Rental bars good condition \$4500 (248) 477 9296
YAMAHA 2000 YZF R1 Blue exc cond 9K miles Warranty \$8,000 firm 734 673-0110

808 Motorcycles/ATV/Snowmobile/Trailer

All aluminum with diamond plate bed like new \$1100 734 397 8167

809 Off Road Vehicles

HONDA RANCHER ES 2001 4 wheel dr low hours electric snow plow \$4500 (248) 305-5557

810 Recreational Vehicles

HONDA FOURTRAX 300 ATV 1999 low hours \$3400/each or best (248) 486-3083
SEA DOO XP 1996 (2) w/trailer Exc cond \$4540 248 614-9928 or 734-478-5200

811 Snowmobiles

ARCTIC CAT ZR800 & ZR500 1995 w/cover helmet & gloves low miles good cond \$2500 & \$1100 2 place trailer \$450 Garage stored 3 yrs Pkg \$3750 (248) 649-9466
POLARIS 2000 550 very low miles exc cond \$3500/best (734) 455 7232
SKI DOO 1981 Citation 4500 Kawasaki 1980 Invader great cond low miles \$2100/best Trailer available 734-397 8167

812 Campers/Motor Homes/Trailers

AEROLITE CUB 2000 21 ft a/c microwave oven stereo and many other extras Exc cond (248) 474-4300
AIRSTREAM 1969 trailer new interior 27 feet long Best offer (248) 689-5937
CAMPLITE 1995 Pop Up sleeps 4 \$4500/best Must Sell Ask for Mike (734) 326 6431
CARGO TRAILER 36 ft enclosed aluminum Hydraulic front leg w/ 5th wheel hitch included \$5500 (734) 560-8766
CARRIAGE 1993 32 ft slide out all electronic all fiberglass \$18 000/ Also F 300 Doolley all set to go w/trailer \$12 000/best (734) 595 0163
CARRIAGE 1994 38 5th wheel w/ Chevy 3500 Crew Cab 4x4 dually \$44 500 734-397-8187
CHATEAU 1999 Class C V10 31 ft 7K hrs large bath generator heated storage TV center \$43 000 734 432 0771
COACHMAN 1996 24ft Cat alina like new loaded/best 3 times \$9200 (734) 522 3230
COACHMAN 1979 32 ft good cond sleeps 8 \$5000 313 388-2842
COACHMAN 1991 26 ft motor home Class C 28K miles exc cond \$17 900 810 229 8570
COACHMAN 1999 Pop up sleeps 8 loaded used twice \$6000 Mike 734 454 7663
COACHMAN 1999 299T 30 ft travel trailer sleeps 8 queen bed loaded \$10 900 734-421 7822
COACHMAN 1998 travel trailer 28 sleeps 8 bunkbeds extras exc cond \$11 600 734-953 9508
COLEMAN 2001 Bayside Pop Up Fully Loaded heater fridge awning hot water tank sleepers 8 \$8300 (734) 487 9928
COLEMAN CAMPER/POP UP 1984 great cond sleeps 6 \$2500 (248) 650-5359
COLEMAN 1996 Keywest pop up camper 26 opened storage bin sleeps 9 bike rack awning \$3500 (248) 442 7258
COVERED 5x8 cargo Knight Trailer Like new \$1300 (734) 525 6008
DIESEL PUSHER 1986 Monaco ft 3208 CAT Custom interior iron paint 2 air condit ioners generator Clean \$58 000 248 651-4672
DUTCHMAN 747XS 1996 pop up sleeps 8 fridge furnace elec brakes etc \$4250 734-953-1129
FOUR WINDS 1999 28 motor home 14K miles exc cond \$36 000 after 6pm 248 486 6441
GULFSTREAM 1997 30 ft 5th wheel slide out front power jacks \$17 500 248 398 5145
GENERAL LOW Boy Trailer 1989 19 ft bed 15 ton capacity 12 wheel electric brakes \$1000 734-284 6772

812 Campers/Motor Homes/Trailers

GMC 1975 Mobile Traveler 18ft motorhome a "Sports man's Special all self contained runs great as is \$3600/best 248 879 6534
HOLIDAY Rambler 1994 Imperial 37 5 Ft 36K great condition (810) 220-8548
HOLIDAY Rambler 1995 Imperial 37 5th wheel w/15 slide-out extras \$25 000 248 879-0841
HORNET 1995 30 ft trailer self contained many extras exc cond \$9200 734-422 0004
HORNET TRAVEL trailer er 27ft 1996 Sleeps 8 micro wave & more Super clean \$6500 734-422 4862
INTRUDER 1994 33ft many extras! Hydraulic leveling Exc cond \$29 900 (248) 887 0820
JAYCO 1999 Eagle pop-up heater awning green blue bike rack (313) 846-1069
JAYCO EAGLE 246 1999 used 3 times plus accessories \$10 500 call (248) 623 1119
JAYCO 1998 26ft sleeps 8 includes power jack linens kitchen accessories & seasonal campsite in Jackson paid through Apr 2002 non smokers air furnace hot water tank bathroom w/ tub/shower \$14 500 (734)844-0866
JAYCO 1990 29 ft sleeps 6 self contained exc cond \$6800 248-488 4230
JAYCO 1007 1997 pop up w/ add a room furnace fridge \$3800/best (248) 894-3419
LAYTON 1997 30 ft 5th wheel w/slideout & many extras \$15 000/best offer Tow vehicle available 248 477 5079
NOMAD SKYLINE 1998 bunk house w/ slide out fully equipped like new \$12 500 734-591 6292 or 734-306-5412
ROCKWOOD 2001 Roo 23 sleeps 7 loaded \$12 500/best (484)678 9717 (248)701 3779
SHASTA 1987 motorhome 37ft low mi good cond air clean \$6900/trade 734 467 1878
SKAMPER CAMPER 1992 24 sleeps 4 large kitchen exc cond \$5500/offer 734-513-8550
SKAMPER TRAILER 1993 27ft sleeps 8 air stereo micro wave \$6500 (734) 782 9980
STARFLITE 1999 22 motor home loaded exc cond non smoker \$25 000 (517) 548 2682
SUNLINE 1996 16ft trailer air stove and fridge like new \$6 700 (248) 544-9371
SUNNYBROOK 1996 light weight travel trailer All options non smoker Must sell \$9 500/best 810 240-1298
TERRY 1990 35ft bunk house loaded exc cond Must Sell \$7000/best (734)729 2322
TERRY LITE 1999 25 Many extras free camping tilt 2004 \$15 500 (734) 427 6743
TOW DOLLY Heavy duty wide track 2 yrs old Large tires \$850 (734) 397 2458
TRAVEL CRAFT 1994 29 ft 460 loaded considered trade 46K \$16 900 734 697 5680
VIKING 2000 Tent camper sleeps 6 Asking \$4 000 or best offer Call 248 328-0950 or view at 2140 Stone Henge Drive off Wilder 28442
WILDERNESS 1992 29ft Queen bed air stereo stove microwave spare tire 2 batteries \$7000 (734)281 7524
WINNEBAGO 1991 Chieftain 33 ft big generator car caddy low miles good cond 989 366 5359
WINNEBAGO 1996 Class A Warrior 14 800 GVW heavy duty chassis sleeps 6 3K, like new \$36 000/best 734 591 2019

811 Snowmobiles

ARCTIC CAT ZR800 & ZR500 1995 w/cover helmet & gloves low miles good cond \$2500 & \$1100 2 place trailer \$450 Garage stored 3 yrs Pkg \$3750 (248) 649-9466
POLARIS 2000 550 very low miles exc cond \$3500/best (734) 455 7232
SKI DOO 1981 Citation 4500 Kawasaki 1980 Invader great cond low miles \$2100/best Trailer available 734-397 8167

812 Campers/Motor Homes/Trailers

AEROLITE CUB 2000 21 ft a/c microwave oven stereo and many other extras Exc cond (248) 474-4300
AIRSTREAM 1969 trailer new interior 27 feet long Best offer (248) 689-5937
CAMPLITE 1995 Pop Up sleeps 4 \$4500/best Must Sell Ask for Mike (734) 326 6431
CARGO TRAILER 36 ft enclosed aluminum Hydraulic front leg w/ 5th wheel hitch included \$5500 (734) 560-8766
CARRIAGE 1993 32 ft slide out all electronic all fiberglass \$18 000/ Also F 300 Doolley all set to go w/trailer \$12 000/best (734) 595 0163
CARRIAGE 1994 38 5th wheel w/ Chevy 3500 Crew Cab 4x4 dually \$44 500 734-397-8187
CHATEAU 1999 Class C V10 31 ft 7K hrs large bath generator heated storage TV center \$43 000 734 432 0771
COACHMAN 1996 24ft Cat alina like new loaded/best 3 times \$9200 (734) 522 3230
COACHMAN 1979 32 ft good cond sleeps 8 \$5000 313 388-2842
COACHMAN 1991 26 ft motor home Class C 28K miles exc cond \$17 900 810 229 8570
COACHMAN 1999 Pop up sleeps 8 loaded used twice \$6000 Mike 734 454 7663
COACHMAN 1999 299T 30 ft travel trailer sleeps 8 queen bed loaded \$10 900 734-421 7822
COACHMAN 1998 travel trailer 28 sleeps 8 bunkbeds extras exc cond \$11 600 734-953 9508
COLEMAN 2001 Bayside Pop Up Fully Loaded heater fridge awning hot water tank sleepers 8 \$8300 (734) 487 9928
COLEMAN CAMPER/POP UP 1984 great cond sleeps 6 \$2500 (248) 650-5359
COLEMAN 1996 Keywest pop up camper 26 opened storage bin sleeps 9 bike rack awning \$3500 (248) 442 7258
COVERED 5x8 cargo Knight Trailer Like new \$1300 (734) 525 6008
DIESEL PUSHER 1986 Monaco ft 3208 CAT Custom interior iron paint 2 air condit ioners generator Clean \$58 000 248 651-4672
DUTCHMAN 747XS 1996 pop up sleeps 8 fridge furnace elec brakes etc \$4250 734-953-1129
FOUR WINDS 1999 28 motor home 14K miles exc cond \$36 000 after 6pm 248 486 6441
GULFSTREAM 1997 30 ft 5th wheel slide out front power jacks \$17 500 248 398 5145
GENERAL LOW Boy Trailer 1989 19 ft bed 15 ton capacity 12 wheel electric brakes \$1000 734-284 6772

814 Construction, Heavy Equipment

LANDSCAPE & CONSTRUCTION EQUIPMENT Tools power equipment trailers fork lift excavator air compressor trenchers pipe pullers trucks (some with plows) lots of misc (248) 354-3213
OVERHEAD CRANES Used & New ST 201 Runway & Mono Rails Installed STINGER RENTAL 313-330-9378 248-449 6218

815 Auto Misc

BAD CREDIT? NO CREDIT? DISCHARGE BANKRUPTCY?? FIRST TIME BUYER? WANT A NEW OR USED CAR OR TRUCK? CALL MARK 734-451-7112 BOB JEANNOTTE PONTIAC-BUICK-GMC

816 Auto/Truck Parts & Service

BLACK Fiberglass flip up bed cover for Chevrolet S10 Sport, side pick up truck. Lockable. All hardwood included. Exc cond. Only \$400 248-393 1146
BLACK TURTLE top for pick up \$500 734-459-4156
BRAND NEW Tremec 5 speed transmission just gear box fits all Ford Mustang applications \$600 (248) 249 8100
CENTURY PICK UP Cap 2001 For Ford ranger FLARE SIDE New price \$1000 will sell for \$800 586 263 4694
CJ7 Hardtop & metal doors \$800 (248) 673 7667
MUSTANG GT 2002 17 in wheels & worn tires \$500/best offer 734-347 3223
PARTS 1977 Blazer full size new GM Q panels rocker panels burgundy interior custom cap lots of parts 313 562 2437 after 6pm
RAVEN CAP 6 ft for Ford super duty truck harvest good Exc cond \$550 (248) 478 9617

822 Trucks For Sale

DODGE 1986 lightly used pick up heavy duty work truck low miles no rust new paint \$2 850 firm (248) 545 0038
DODGE 1998 3500 Quad Cab Dooley red 43K any reasonable offer Days 888-592 1301 313 538-0523
DODGE 1995 Ram 1500 4x4 318 auto 95K \$7000 After 5pm 810 687 4274
DODGE 1998 Ram 1500 4x4 50K miles white sport package \$14 000/best 734-762 0401
F250 1999 diesel extended cab approx 32K miles engine heater am/fm CD Rhino liner trailer hitch asking \$25 000/best 734 522 7608
FORD F350 1996 Aluminum Box Truck w/lift gate Auto air clean \$5550 (734) 697-6348
FORD 1999 F350 Crew dual wheels Diesel 4x4 low miles loaded Assume lease or buy \$29 900 (734) 455 6158
FORD 1999 F350 diesel dualie loaded 14K exc cond \$31 500 Bob (888) 463 8687
FORD F150 1996 Eddie Bauer w/cap tonneau cover exc cond \$5300/best 734 285 3069
FORD F100 Ranger 1987 460cu in TN truck runs/looks great \$2800/best 810 743 8247
FORD 1999 F150 Sport XLT 57K miles V 8 power every thing \$15 200 248-427 0865
FORD F150 1997 super cab Lanat burgundy V8 loaded leather mint warranty \$4K \$13 500 (313) 406 9248
FORD F250 1977 407 super cab new tires new trans 460 cu in \$2950/best Call (734) 688-3309
FORD 1995 F450 Super Duty 7.5 V8 5 speed 12 stake bed 69K SOLD
FORD F150 1995 4x4 Eddie Bauer extended cab Exc cond \$9500/best (248) 634 3667
FORD 1996 F150 XLT chrome wheels power windows/locks stereo/tape 5 speed mint \$14 995 29 Fin Available! OPEN SATURDAY 10-3 LAW AUTO SALES (734) 722-5200
FORD 2000 F150 XLT extended cab 5.4 liter 28K miles \$17 500 (734) 721 7741
FORD F150 XLT Lariat 1991 4x4 w/ lift gate Clean good cond \$5500/OBO (734)425-5296 or (248)427-9475
FORD F150 XLT 1996 matching cab loaded air cruise dual gas tanks \$6500 248 240 3010
FORD F150 XLT 1996 matching cab loaded air cruise dual gas tanks \$6500 248 240 3010
FORD F150 XLT 2000 5 speed exc cond extras must sell \$17 500 (248) 683 3750
FORD 1998 F150 XLT Super Cab V8 AT cap bed net towing \$12 500 734 398 5079
FORD 2000 Ranger extended cab V6 fully loaded 30K mi 1 owner \$11 000 734-427 4743
FORD RANGER 1993 longbed tonneau 98K 3.0L V6 5 speed \$2 600/best 313 937 6347
FORD RANGER 1999 S/cab XLT 4x2 auto V6 loaded exc cond chrome wheels red 45K \$9450 (810) 220-2191
FORD RANGER 1998 Super cab Loaded black exc cond 53K \$7800 (248) 736-0756
FORD RANGER 1998 Supercab 4x4 Off Road Auto 19er loaded 50K \$14 500 734-453 0701
FORD 2001 Ranger 4x4 double cab 4 door one owner 35k mi \$16 500 (248) 328 9475
FORD 1997 Ranger XLT Long bed 2 wheel drive V 6 3.0 28 000 miles \$9 500 Call (313) 415 4930
FORD RANGER XLT 1994 4.0L V6 5 speed good cond new tires & brakes 1 owner \$5 250 (734) 398-6499
GMC SIERRA SLT 2000 4dr trailer package 10K miles Exc Cond \$20 500 734-427-4841
GMC 1995 Sierra SLT 4x4 snow plow salt spreader \$6500 or best offer 734 455 6164
GMC SIERRA 1999 3/4 ton 4x4 7.4L V8 fully loaded low miles \$17 500 313 295 3197
GMC SLE 1999 4x4 3rd door auto 5300 V8 power chrome wheels bedliner 68K miles \$15 600/best (313) 563 2381

822 Trucks For Sale

GMC SONOMA 1997 66k mi manual trans 5 speed bedliner \$4500/offer 248-752 1102
GMC 2002 Topkick C6500 Vulcan 21 ft steel flat bed wheel lift removable rails original equip ment, 8 1 gas auto air am fm Viper alarm 2750 mi original warranty \$52 000/offer 313-538-7050
RANGER 1996 auto air \$3499 TYME AUTO (734) 455 5566
RANGER 2001 Supercab XLT w/tonneau \$14 900 STU EVANS Garden City 800 718 7371
SUBURBAN 1993 SILVERADO SL 3rd seat 120K miles good cond \$7200 (734) 483 4432

824 Mini-Vans

AEORSTAR 1993 4 0 Extended 80K loaded \$4500/ best 248-473-2079 248-705-5540
AEROSTAR 1990 extended V8 fully loaded runs great CD hitch \$2800 (734) 454-4660
AEROSTAR 1993 very clean \$3900/best Call after 5pm (734) 458-7591
AEROSTAR 1994 XL 128K good cond new tires shocks & exhaust \$3400 248 645-6956
AEROSTAR 1994 XLT 1 owner 96K air Black out/gray in \$3400/best 248 661 0202
ASTRO 2000 two tone paint privacy glass CD alloy wheels and AWD too! \$14 995 29 Fin Available! OPEN SATURDAY 10-3 LAW AUTO SALES (734) 722-5200
CARAVAN 2001 factory warranty remaining \$15 900 STU EVANS Garden City 800 718-7371
CHEVY ASTRO 1994 CL EXT 8 passenger power brakes/steering air aluminum wheels \$4500/best (734) 459 4855
CHEVY LUMINA 1996 APV auto V6 tilt/cruise air original new brakes & tires \$6450 (248) 647 0477
CHEVY 1999 Venture 4 door extended loaded warranty \$13 900 248-474-0944
CHEVY VENTURE 2000 LS extended VCR power windows \$17 999 248-683-2951
DODGE CARAVAN 1995 V 6 full power dual air 68K clean \$5800 (734) 522-8629
DODGE GRAND CARAVAN 2000 5 dr 3.9L 39K power package \$13 995 (734) 425-2686
DODGE 1998 Grand Caravan LE 4.7K miles original owner \$11 500 (248) 669-5106
DODGE GRAND CARAVAN SE 1990 runs good 150K air FM Cassette \$2000 (734) 522-8504
DODGE 1996 updates exc cond \$3299/best (313)255 0496
FORD AEROSTAR 1993 High Top Conversion Low miles very good cond no rust loaded \$5200 734 729 7008
FORD AEROSTAR 1994 \$83 500 mi tan loaded exc cond \$4500/best (734) 484 1165
FORD AEROSTAR 1995 SLT 8 passenger V 6 great condition \$4095 (248) 932 3243
FORD 98 Windstar GL loaded quad 42K \$9500 (248)540-8560
FORD WINDSTAR GL 1998 loaded V6 new tires/brakes exc cond \$7595 734-421 5334
FORD WINDSTAR 1996 GL white fully loaded V6 new tires alloy wheels luggage rack rear air/stereo exc cond \$6200 (734) 422 4348
FORD 1998 Windstar LX good condition in & out new brakes \$4000 (734) 453-6858
GMC 1998 Safari slt AWD 7 passenger good condition 67K mi \$11 900/best 248 646-2435
GRAND CARAVAN 2000 exc cond 24K full power w/hitch \$15 500 734 459-0389
GRAND VOYAGER 1993 LE 3.3L exc cond 113K 1 owner \$3950 313 937 0092
GRAND VOYAGER 1994 3.3L \$4995/best 810-499 7644
GRAND VOYAGER 1992 3.3L 1 owner new tires/brakes rebuilt trans \$3400 586-246-3742

824 Mini-Vans

GRAND VOYAGER SE 1996 loaded clean warranty 62K \$9 200 248 620 3035
MERCURY VILLAGER 1997 all power rear heat very clean \$7900 (734) 464-7386
MERCURY VILLAGER 1999 18 500 miles exc cond \$14 000 (734) 542 1355
MONTANA 1999 Extended 4 dr auto air power door \$17 698 RedHoban Westland (734) 721 1144
MONTANA 2001 quad seats power doors aluminum wheels dual air and yes low miles too \$15 495 29 fin available! OPEN SATURDAY 10 3 LAW AUTO SALES (734) 722-5200
OLDS 1999 Silhouettes Premier LTD Edition 50K highway miles fully loaded including rear air video player & towing package Seats 7 indigo blue asking \$16 500/or best 734-518-9321
PLYMOUTH VOYAGER 2000 7 passenger air cassette 15 000 miles exc cond estate sale \$12 000 313 537 0750
PONTIAC 1999 Montana extended 29k loaded exc cond \$16000 248 625 9855
TOWN & COUNTRY 1994 1 owner like new loaded 77K miles \$7900 (248) 398 0557
TOYOTA 1992 Previa all power air w/new remote security catalytic converter battery/alternator belts paint good brakes/shocks/tires 1 owner 120K \$5500/best 248 626-4840
VILLAGER 1995 GS aluminum wheels dual air stereo/tape low miles don't miss this \$5 995 OPEN SATURDAY 10 3 LAW AUTO SALES (734) 722-5200
VILLAGER SPORT 2000 20K Black CD player 7 passenger \$16 700 SOLD
VILLAGER 1998 Sport running boards rms \$9 800 STU EVANS Garden City 800 718 7371
VOYAGER SPORT Wagon 1995 3.0L 7 passenger exc cond \$5600/best 734-397 5621
WINDSTAR 1998 blue 54K miles new tires excellent cond tune \$5500 (313) 292 9322
WINDSTAR 1995 LX loaded emerald green 60k rear air \$7 000 (734) 465 2973
WINDSTAR 1996 LX willow green auto rear air loaded \$5500 (248) 442 9472
WINDSTAR 1996 super clean original owner 3.8l dual a/c ABS airbags cruise control hitch new brakes high mileage \$4500 (248) 348 0173

826 Vans

CHEVY 1991 Coachman conversion van blue Perfect for sportsmen Great shape V8 89 000 original mi Will sell for \$5495 Call 248 785-5566
CHEVY Express 1500 1998 8 passenger front/rear air 49K \$12 500 734 953 7526
CHEVY 1995 G20 air 60K miles nice \$3500/OBO (248) 476 1914 after 5pm
CHEVY 1995 G20 dark green clean 77K miles \$6 000/best (248) 852 5262
DODGE 1997 B250 Cargo V8 auto good body Reliable new tires \$4900 734-261 6323
DODGE 1996 2500 Cargo cruise air tilt shelves work boxes very low mi 734-280-3621
DODGE 2000 cargo van extended 1 ton must sell! 248-353-2763 248 910 9770
DODGE 1997 conversion V8 TV fold down bed green \$7800 (734) 459-8026
DODGE CONVERSION VAN 1999 full size low miles \$14 000/best 734 812 0092
DODGE 2500 Hi Top Custom Camper Van (1996) 49K miles 360 engine campground hookup TV VCR interior lights privacy curtains sofabed stove/top kitchen sink fridge portable toilet closet 4 brand new tires warranty to 100K \$10 000 firm 734-425 5247

826 Vans

DODGE RAM 1993 250 60K V8 5.2L air power windows/locks cruise ABS brakes Tow pkg \$4900 (734) 425 9025
DODGE V6 Conversion 4 captain chairs super clean 65K mi \$2500/best 734-591 2917
FORD 350 CARGO VAN 1997 \$7600/OBO Call 313-304 2999
FORD 1998 Club Wagon Chateau V8 towing package w/Class IV hitch remote auto start 104K Very Good Cond! \$9500 (734) 451 5415
FORD CONVERSION 1994 high top leather V8 61K exc cond \$6000 (248) 305-5557
FORD 1992 E 250 cargo van runs/looks great many new parts \$3400 (313) 937 0870
FORD 1994 E150 Chateau wagon fully loaded great cond 102K miles \$4800 or best offer (313) 533 5309
FORD 1997 E150 Debutante Conversion TV/VCR dual air leather raised roof let the vacation begin \$10 995 OPEN SATURDAY 10 3 LAW AUTO SALES (734) 722-5200
FORD E 150 Eclipse Conversion Van 1994 V8 loaded exc cond 1 owner \$5900/best (734) 464-9854
FORD E 150 XLT 1989 V8 auto loaded clean 1 owner \$2900 (313) 638 5865
FORD VAN 1985 150K guns good some rust 4 Captains chairs \$1500/firm (734)464 9022
GMC STARCRAFT 1994 high top loaded + 58K Bloomfield Hills \$11 800 (248) 540 1470
MERCURY VILLAGER 1996 exc cond all power ABS rear heat & air 96K freeway miles \$7000 (248) 559 6264

828 4 Wheel Drive

JEEP 1996 Cherokee Country 4x4 4 door loaded hitch 93K \$7200 248 882 7424
JEEP COUNTRY 1993 4 wheel dr full power loaded New parts newer tires 73K exc cond \$7500 248-477 2116
JEEP 1993 Wrangler CD hard/soft tops exc cond original owner \$6500 (734) 454 3635
JEEP WRANGLER 1999 SE air hard top steel wheels new tires low miles \$13 500 (248) 919 9930
JEEP 2001 Wrangler Sport on ventilate stick under 3000 miles air \$15 500 (248) 477 5245
NISSAN 2000 Frontier crew cab 4x4 loaded \$17 500 Payer 734 5

829 Sport Utility

EXPLORER 1996 LTD exc cond fully maintained remote start \$8500/best 248 229 8811

EXPLORER 1999 Sport 4x4 rec \$15 800 STU EVANS Garden City 800 718 7371

EXPLORER 4x4 1995 leather 6 disk CD loaded hitch new battery & brakes looks & runs exc \$7000 734-981 2076

EXPLORER 2000 XLT black leather sunroof power win dows doors CD 30K miles \$17 750 (248)693 8360

EXPLORER 1997 XLT 4 dr leather new trans auto 90K \$9800 (248) 960 0546

EXPLORER 1997 XLT 4x4 loaded 75K miles \$9 300 (248) 360 4909

FORD ESCAPE LTD 2001 600 MI Leather step bar Mach Audio/6 CD in dash moon roof & more! Moving Must sell! Only \$23 999 (248)334-1098

FORD 2000 Excursion Limited leather CD dual air V 10 3rd seat chromes 4x4 how about this? \$23 495 29 fin available! OPEN SATURDAY 10 3 LAW AUTO SALES (734) 722-5200

FORD 1997 Expedition black leather 5 4L 4x4 tow package 3rd seat clean great cond \$14 000/best 734-782 5272

FORD 1997 Explorer Sport 4x4 great shape new brakes \$9 999/best 248 640 5398

FORD EXPLORER SPORT 1999 air CD auto start new tires moonroof power every thing great shape 51 000 miles \$13 000/best Call 734 634 0909

FORD EXPLORER Sport 1996 2dr 66K miles CD leather new tires \$9 300 (734)425 1494

FORD 1994 Explorer XLT 4x4 loaded rustproof like new \$7300 (313) 532 4403

FORD EXPLORER 1997 XLT Leather 4x4 4 dr \$10 000 Canadianized (248) 855 9373

FORD 1998 Explorer XLT 31K miles 4 0 4 door air CD \$14 300 (734) 522 8323

FORD EXPLORER 1993 XLT 4x4 97K mi fully loaded \$6 000 or best (734) 427 1404

GMC 2000 Denali black dia mond chrome wheels CD dual air 4x4 that has it all! \$24 995 29 fin available! OPEN SATURDAY 10 3 LAW AUTO SALES (734) 722-5200

829 Sport Utility

JEEP 1996 CHEROKEE cd power equipment 4 0 4x4 tow pkg rec 65 000 miles \$9 599 or best offer (248) 672 2336

JEEP CHEROKEE LTD 2001 very clean exc cond 20K Miles \$17 900 248 681 7109

JEEP CHEROKEE SPORT 1996 4x4 body good cond engine exc cond \$7 900 (734) 427 5470

JEEP 1999 Cherokee Sport 16 250 miles beau tiful cond \$13 000/best Must Sell Quick! eshank125@yahoo.com

JEEP GRAND CHEROKEE 1997 amethyst 90K V 6 \$7000 best (734) 459 1999

JEEP 1995 Grand Cherokee Limited 4WD loaded only 72 000 mi \$7900 248-391-6270

JEEP 2000 Grand Cherokee Laredo black one owner new car in \$17 800 or best offer (313) 937 0127

JEEP 2000 Grand Cherokee Laredo 4WD excellent cond 20 000 mi Khaki \$20 500 (248) 645 0008

JEEP GRAND Wagoneer 1990 Runs great 150K+ miles body exc \$5900 248-363-9781

LINCOLN 1999 Navigator white loaded 99K miles exc cond \$27 000 248-884-7330

MOUNTAINEER 2000 Monterey Edition leather CD chromes AWD V 8 and power moon roof \$16 995 29 Fin Available! OPEN SATURDAY 10 3 LAW AUTO SALES (734) 722-5200

OLDSMOBILE 2000 Bravada Platinum series 1 owner loaded must sell 248 855 0438

PASSPORT 2000 EX Excellent Condition Call 734 484-0199

PASSPORT HONDA 2001 LX 4x4 V 6 black 10K miles \$18 500 (734) 612 7044

SUBURBAN 1995 1500 LS white great cond \$9500/OBO (734) 427 3944

TAHOE 1999 dark blue/dark blue leather int New tires & brakes Clean & loaded \$18 000 248 478 4484

TOYOTA 1999 Land Cruiser Grand loaded under 50K mi exc cond \$31 000 248-684-7330

830 Sports & Imported

BMW 2000 323ci 5 sp silver coupe sport pkg moon roof xenon lights 21K mi \$28 000/ or best offer (248) 651 0688

BMW 1993 525i black/black full power auto sunroof 93K miles exceptionally clean & well main tained \$10 750 248 761 1328

BMW 325iC Convertible 1987 98K miles black auto nice car \$4100 (810) 813 3577

BMW 1998 328i Green/Beige exc cond 36K miles loaded premium sound CPD warranty \$22 500 734 765 8804

BMW 1998i Green/beige fully loaded exc cond BMW certified \$23 500 Mark (734) 765-8804

BMW 330i 2001 Immaculate condition purchased in Aug 00 No acc dents \$32 000 248 568 2477

BMW 525i 1995 80K green loaded \$14 000 (248) 887 3030

BMW 1968 750 IL white/camel 85K \$5000 in new parts exc cond \$11 000 248 816 9475

BMW 1993 740i V 8 auto loaded all options 128K exc cond \$11 500/best 734-564-6054

BMW 1995 M3 black w/gray interior sunroof 5 speed 84K miles \$21 000 (248) 933 5667

BMW 2000 M Roadster Metallic silver/black leather WARRANTY No winter driving Looks great runs great Must sell \$32 9800/best 810 777 1117

BMW 2001 330w All wheel drive all options 8 speed 23K miles \$34 500 248 651 8860

CHEVY CORVETTE 2001 Con vertible Loaded! Triple black 6 speed CD needs up display chrome wheels Head turning car \$43 500 313 920 7887

CHEVY CORVETTE 1974 Con vertible low miles good cond \$8 800 (248) 945 9761

CORVETTE 1981 auto t tops aluminum wheels power win dows & doors 47K miles \$9 500 (734) 261 3217

CORVETTE 1989 convertible auto triple black, 78K exc cond \$14 900/best 248 730 5342

CORVETTE 2001 Convertible Green/tan 8 speed loaded 12K chrome wheels gorgeous! \$40 500 (248) 593 5201

830 Sports & Imported

FIATS (2) 1957 great cond & 1961 fair cond \$1400/pair (248) 477 1068

FORD 2000 MUSTANG CONVERTIBLE beautiful blue V 6 automatic transmission air 16K showroom cond factory warranty fully power including the top premium radio cd and cassette keyless entry Good year Eagle tires \$17 995 (248) 693 8117

HUNDAI 2000 Accent 3600 miles cassette 5 speed manual \$5000 734-522 1737

JAGUAR XJ6 1990 107K miles wire wheels loaded \$4 450 (734) 765 3267

JAGUAR 1989 XJ6 Las Vegas car \$15 000 invested \$8500 Exc cond (734) 462 2063

JAGUAR 1989 XJ6 Las Vegas car \$15 000 invested \$8500 Exc cond (734) 462 2063

JAGUAR 1996 XJ6 white/tan 74K miles exc cond Warranty \$17 900 248 789 4172

JAGUAR 1997 XK8 Convert ible Pristine Carnival Red war ranty \$32 900 313 310 0110

MAZDA MIATA MX5 1994 Black 5 speed air stored win ters clean exc cond \$9 500 Leave Message 248 399 3045

MAZDA MIATA 2000 special edition 6 speed loaded mnt cond only 9500 miles \$18 000 (248) 380 7240 after 6pm

MERCEDES 1989 560 SL great cond white \$18 000 (586) 954 1005

VINTAGE MERCEDES BONANZA! 1969 SE 1970 SE & 1968 SL package \$28 000 248 701 5885

MERCEDES BENZ 1999 500SL Roadster factory warranty con vertible extra hardtop Premium sound system sub woofer leather interior phone \$55 700 Bob 248 891 4511

MERCEDES BENZ 1990 480i White Good cond runs well \$3 500/best Call 313 779 0576 or 248 639 8481

MERCEDES 1999 C230 Kompressor red w/black leather fully loaded very clean 49 000 mi \$23 500 248 202 6886

MERCEDES 1999 CLK430 AMG black coupe writer wheels, 41K warranty \$38 000 (734) 207 1767

MERCEDES C280 Sport 1997 78K miles Silver Fine Car \$16 500 248 473-4033

830 Sports & Imported

PORSCHE CARRERA 1993 Classic red titanium trans leather retracting spoiler 75K mi \$28 900 (517) 548 2466

PORSCHE 911 Coupe 1987 red black leather spoilers 16 Fuchs sunroof loaded 89K miles \$25 900 248-475 8831

PORSCHE 2000 Like new! Triple black Carrera convertible Under warranty \$72 000/OBO (734) 358 1935

SAAB 2000 93 Convertible rare white w/ blue top auto leather/w/wood loaded! 35K miles \$21 9 000 248 626 9825

TRIUMPH SPITFIRE 1500 1974 convertible great shape \$4500 \$10 333-2138 or 517 552 3831

TRIUMPH 1973 Spitfire white convertible runs good \$2500 (734) 421 7364

VIPER 1998 12K mi stored in heated garage \$50 000 firm (248) 825 7883

VOLVO 780 (1988) Bertone rare Italian made turbo 2 dr black w/leather interior \$6800/best (734) 453-3994

VOLVO 1999 S80 2 9 fully loaded all options exc cond \$19 900 248 240 4137

VOLVO 240 WAGON 1993 silver/navy 96K mi 1 owner outstanding cond auto starter power doors & windows \$8 500 (248) 588 5459 after 2 p m

832 Antique/Classic Collector Cars

CORVETTE 1973 Stingray 350 engine 65K T tops red \$11 000 (810) 735 4326

CORVETTE 1978 25th anniver sary 55K miles 4 speed rec fect \$13 300 734-462 0929

FORD GALAXY 1965 390 black/black 69K miles original paint \$4 900 (248)347 6069

FORD PICKUP 1968 very good cond 64 000 miles 1 owner \$3000 (248) 693 3985

FORD 1964 THUNDERBIRD cream color auto asking \$3000/ best offer 734 522 7806

LINCOLN COUPE 1950 Rare Hot Rod Lincoln Mild custom original 337 cu in flathead & auto transmission Bubble skirts Lakes pipes Recent new paint upholstery & chrome Texas car no rust Drives great Excellent show car Many parts Must sell \$16 500 (734) 455 5459

MGA 1960 ROADSTER 1960 very good mechanically older paint & interior many extras \$8500/OBO (248) 788-1391

MUSTANG 1967 coupe 6 cyl sprint mint condition Garaged Recent restoration 248-344-4908

OLDS 1979 Toronado gold 54 000 miles good cond garage kept \$3000/best After 12pm 734-522-3273

PONTIAC 1982 "Star Chief" all original restorable \$4000/ best 248-356-0322

SCORPIO 1987 16V 113K miles Calif car new clutch & transmission etc \$4700 248 642 6573 248 548-2244

SEDIAN 1960 \$4 000/firm (734) 416 8849

TIFFANY CLASSIC 1984 white V 8 30K original miles \$22 999/ best (734) 455 3501

TRIUMPH TR3 Convertible 1960 green/black good cond no rust \$8500/best Royal Oak (248)544 3881

CAMARO 1986 Sport Coupe IROC Z28 showroom 1 of a kind 46K 2888 inquiries (313) 555 0916

CAMARO 1979 Pennsylvania car solid body no bondo \$1950 734-591 3688

CHEVROLET 1956 Belaire 4 dr hardtop Blue/white auto completely restored \$12 500 734-522 8168

836 Buick

PARK AVENUE 1991 4 dr very reliable trans navy blue \$2500 (734) 425 1617

PARK AVENUE 1999 36K miles exc shape 1 owner leather \$16 500 (734) 459-1474

REGAL GS 1997 V 6 super charged leather full power key less entry am/fm cassette cd excellent cond 59 000 miles \$10 495 (734) 459 5627

REGAL LS 1998 loaded 29K warranty \$10 750 (248) 855 2535

REGAL 1997 1/2 LS sedan CD cassette player exc cond Non smoker \$9 250 248 628 6201

REGAL 1998 40K sunroof power leather seats CD \$11 000 Troy 248 828 2994

RIVERIA LOADED 132K highway miles 57K or offer Private 248 363 0236

838 Cadillac

SEVILLE 2000 STS low miles astro roof chrome wheels CD \$26 980 Priced to sell John Rogin Buick 734-525 0900

SEVILLE STS 1994 pearl white 130K runs and looks good \$5500 (734) 420 3396

SEVILLE 1999 STS white dia mond chromes CD heated seats chromes power moon is there more?? \$20 995 29 fin available! OPEN SATURDAY 10 3 LAW AUTO SALES (734) 722-5200

CAMARO 1998 Black V 8 auto loaded 25K miles exc cond \$21 900 (734) 748 3135

CAMARO CONVERTIBLE 1999 red auto 3800 engine Mon soon radio 22K miles car show winner \$16 900 734 591 2280

CAMARO 2000 convertible loaded 19 000 miles like new power \$19 990 (248) 335 8353

CAMARO 1996 3 8 V 6 5 speed air alarm pw/pl low miles exc cond \$7450 248 324-1184

CAMARO 1999 2 8 Convert ible auto bright red w/chromes CD 2K priced to sell! Save! John Rogin Buick 734-525 0900

CAMARO SS 1999 6 speed 2 tops leather fully loaded stored writers mint cond Many extras! \$20 000 (734) 425 0408

CAPRICE CLASSIC 1994 V 8 5 7L auto 33 000 miles \$5900 Call after 7pm (248) 879 6055

CAPRICE 1994 police car new paint & parts SS options immaculate \$10 750 (734) 844-8296

CASH For your used car Dealer needs cars My wife says I pay too much! For phone appraisal TYME 734-455-5566

CAVILLER 1994 4 dr clean Good cond 103K miles air 1 owner \$2 500 (313) 538 6688

CORSICA 1994 V 6 auto air Blue 100K Clean Well main tained \$3000 489 1353

IMPALA 2001 18K fully loaded midnight blue and waiting just for you! \$14 995 29 fin available! OPEN SATURDAY 10 3 LAW AUTO SALES (734) 722-5200

FLEETWOOD 1988 gray clean with no rust newer motor & tires \$2900 734 453 7661

SEDAN DEVILLE 1989 black exc cond leather & loaded CA mi \$3500/best 248 334-3553

840 Chevrolet

LUMINA LS 1996 loaded white 71K immaculate cond \$8600 (734) 425-2207

LUMINA 1995 mechanics spe cial All power Cruise air ABS \$3000/best (734) 432 0529

MALIBU 1999 6 cyl white loaded exc cond 40K miles \$9200 734-737 0090

MALIBU 1999 32K miles CD remote entry V 6 power door/ windows \$6 500 248 624-1021

MALIBU 1999 LS loaded beige exc cond 35K non-smoker \$10 200 734 729 3990

METRO 2000 LS! auto air, air great transportation \$5 999 Westland (734) 721 1144

MONTE CARLO 1999 leather moon all the right stuff! \$13 988 Westland (734) 721 1144

MONTE CARLO LS 1995 red loaded exc cond \$4800 8r best offer (248) 625 6074

MONTE CARLO 1995 234 fully loaded great shape alarm/ starter \$5200 248 738 5990

CHRYSLER 2000 300M mint cond 9 300 miles \$20 000 (248) 960-2299

CHRYSLER 300M 1999 power windows chrome wheels well-maintained 57 500 miles \$16 200 (248) 363 7615

CIRRUS 1996 LXI loaded exc cond \$3 500/best 248 788 7773

CONCORDE 1995 exc cond 1 owner air cruise power, windows/locks 80K miles \$4500/best (248) 476 7332-

CONCORDE 1996 exc cond loaded new tires warranty \$6100/best (734) 261 1802-

CONCORDE 1994 40K mi on new transmission mint 5900 brakes/tires/air well maintained \$3999/best 313 532-5934

CONCORDE 1994 40K mi on new transmission mint 5900 brakes/tires/air well maintained \$3999/best 313 532-5934

CONCORDE 1994 loaded 1996 interior deep red 58K sunroof exc cond (734) 422 7662-

ANDERSON SALES and SERVICE KEEP THE BALL ROLLING 2002 HONDA TRX350TE RANCHER M.S.R.P. \$4599.00 2002 HONDA TRX450FE 4X4 M.S.R.P. \$6399.00 6.9% for 24 months* with No Down Payment OR Low Monthly Payments* with the Honda Card™ for the first 2 years 2002 HONDA TRX350FE RANCHER M.S.R.P. \$5399.00 \$69 On Recon or Sportrax™ 250EX 2002 HONDA TRX500 RUBICON M.S.R.P. \$6999.00 TRADE INS WELCOME NOW ON SALE ONLY \$3999.00* NOW ON SALE ONLY \$4999.00* honda.com BE A RESPONSIBLE RIDER ALWAYS WEAR A HELMET EYE PROTECTION AND PROTECTIVE CLOTHING AND PLEASE RESPECT THE ENVIRONMENT OBEY THE LAW AND READ YOUR OWNERS MANUAL THOROUGHLY. *See text one and two only subject to change without notice. 4.9% APR financing for 36 months on any new 2002 Honda Shadow 1100, Shadow 700, VTX 1800, Magna 700, or Rebel through American Honda Finance Corporation upon approved credit. No down payment does not include tax, license and other fees. Financing available to qualified customers subject to credit approval from Consoco Bank Inc. on the Honda Card program at participating Honda Dealers. Total balance after 24 months and on purchases other than initial offer during promotional period are subject to the increased Standard Program APR and minimum monthly payment 2.5% of the original credit plan balance minimum payments and 16.75% APR. Standard Program APR may vary (16.75% as of 3/31/02). Finance charges begin to accrue on date purchase post to account. All transactions are subject to the terms and conditions of the Carholder Agreement. Offer good 3/01/02 - 5/31/02 on new 02 and prior models. Check with participating Honda Dealers for complete details. Shadow™, Rebel™ and Honda Card™ are trademarks of Honda Motor Co. Ltd. ©2002 American Honda Motor Co. Inc. (302)

THIS COULD BE THE MOST IMPORTANT PHOTO YOU'LL EVER TAKE OF YOUR CHILD. On Thursday, Blackwell Ford Inc, your Blue Oval Certified Ford Dealer, is hosting Commitment to Kids, a free Child Safety event. Parents of the first 200 children will receive a complimentary ID kit. Children's photos will be taken free of charge. Come on in and bring the kids. Just to be safe. Thursday, May 2nd, 2:00 p.m.-6:00 p.m. Commitment to Kids 1-866-BLUEOVAL blueovalfordvehicles.com Blackwell Ford Inc. 41001 Plymouth Rd. (Just East of Haggerty) Plymouth 734-453-1100

Get Out Of Your GMAC Lease!

If you have a GMAC lease that expires between May 1, 2002 and September 30, 2002* you can get out of your GMAC lease early at no cost! Lease another Buick or Pontiac from Fresard Pontiac/Buick and get up to a \$750 loyalty bonus! But hurry, you only have a few weeks to take advantage of this special offer



"Where Nice Things Happen"

You could save thousands!!

PONTIAC "Driving Excitement"

<p>2002 Grand Am SE</p> <p>\$0 Down Lease! 36 Months/36,000 mi.</p> <p>\$209* GMS</p> <p>Security Deposit Waived!</p>	<p>2002 Montana</p> <p>\$0 Down Lease! 36 Months/36,000 mi.</p> <p>\$269* GMS</p> <p>Security Deposit Waived!</p>	<p>2002 All-New Aztek</p> <p>\$0 Down Lease! 36 Months/36,000 mi.</p> <p>\$259* GMS</p> <p>Security Deposit Waived!</p>
<p>2002 Vibe</p> <p>\$0 Down Lease! 36 Months/36,000 mi.</p> <p>\$329* GMS</p> <p>Security Deposit Waived!</p>	<p>2002 Grand Prix</p> <p>\$0 Down Lease! 36 Months/36,000 mi.</p> <p>\$259* GMS</p> <p>Security Deposit Waived!</p>	<p>2002 Bonneville</p> <p>\$0 Down Lease! 36 Months/36,000 mi.</p> <p>\$294* GMS</p> <p>Security Deposit Waived!</p>

BUICK It's All Good

<p>2002 Rendezvous</p> <p>\$0 Down Lease! 36 Months/36,000 mi.</p> <p>\$284* GMS</p> <p>Security Deposit Waived!</p>	<p>2002 LeSabre</p> <p>GMS Purchase Was \$25,190</p> <p>Save \$6764!</p> <p>SALE \$18,426*</p>	<p>2002 Century</p> <p>\$0 Down Lease! 36 Months/36,000 mi.</p> <p>\$293* GMS</p> <p>Security Deposit Waived!</p>
---	---	--

SUZUKI

<p>2002 Esteem Wagon</p> <p>Save \$3375!</p> <p>Purchase Was \$15,374</p> <p>SALE \$11,999*</p>	<p>2002 X-7 5 speed</p> <p>\$0 Down Lease! 36 Months/36,000 mi.</p> <p>\$299*</p>
<p>2002 Grand Vitara</p> <p>\$0 Down Lease! 36 Months/36,000 mi.</p> <p>\$299*</p>	<p>2002 Ario</p> <p>Save \$2075!</p> <p>Purchase Was \$13,074</p> <p>SALE \$12,999*</p>

248/547-6100 • 1/800-FRESARD

www.fresard.com



"Where Nice Things Happen"

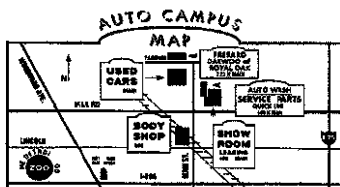

On Main Street Just North of Eleven Mile, Royal Oak

GMAC Lease Loyalty Qual'ed Customers plus tax license destination acqu's ton fee All rebates to dealer Pr'ng subject to change w/ thout not ce Dealer part cpa ton may affect consumer cost Vehicles subject to prior sale Picture may not represent actual veh cle Closed end 36 mo lease w th approved cred t 12,000 mi per year w/20¢ per m excess charge Lessee has opt on to pur chase veh cle at lease end at pr ce to be determined at lease incept on Lessee responsible for excess wear and tear Pr'or sales excluded Pr'ng includes all incent ves and rebates

Observer & Eccentric

AUTOMOTIVE

www.observerandeccentric.com

<p>866 Plymouth</p> <p>BONNEVILLE SSE 1994 red loaded looks and runs great \$3850/best (248) 366 9340</p> <p>BREEZE 1998 auto air super low miles V 6 \$6 988 <i>RedHoban</i> Westland (734) 721 1144</p> <p>BREEZE 1998 exc cond 68K, new brakes/tires & auto car starter \$5600 (313) 534-5275</p> <p>LASER 1992 Red sunroof 4cyl 5 speed manual Am/fm w/ tape air ps/pb good tires non smoker 163k mi Good Cond \$2500/best 248 391 4876</p> <p>MUSTANG 1998 convertible loaded one owner 65K miles \$10 900/best 734 420 3136</p> <p>NEON 1996 air sun roof power steering/brakes auto minor damage low miles \$2500/best (734) 464 2452</p>	<p>868 Pontiac</p> <p>FIREBIRD 1999 auto black T tops loaded \$11 900/best offer 248 348 2404 248 212 4919</p> <p>FIREBIRD 1999 Formula low miles exc cond auto loaded t tops \$17 500 (734) 765 0717</p> <p>FIREBIRD 2000 Trans AM Con vertible WS6 pkg Ram air auto chrome wheels red fully equipped priced to sell! John Rogin Buick 734-525 0900</p> <p>FIREBIRD 2001 Trans AM WS6 pkg ram air auto chrome wheels white fully equipped only 8K priced to sell! John Rogin Buick 734-525 0900</p> <p>GRAND AM 1994 auto air very clean low miles \$3500 TYME AUTO (734) 455 5566</p> <p>GRAND AM 1993 4 dr SE sedan immaculate fully loaded non smoker 1 owner 33 L V6 engine \$3950 248 427 0070</p>	<p>868 Pontiac</p> <p>GRANDAM 1998 Gt Sedan 55 900 hwy miles Purple extras cd \$9600/best 248-624 5846</p> <p>GRAND AM GT 2000 V6 black 32K \$13 599 (734) 454-3567</p> <p>GRAND AM 1999 75K highway miles exc cond brand new brakes \$7500 (248) 393 5781</p> <p>GRAND AM 1999 SE auto air 2 dr sunroof Black Beauty 42K \$8900 (734) 425 7161</p> <p>GRAND AM 2000 SE Auto air power blue 10 000 miles \$14 995/best (248) 901 2310</p> <p>GRAND AM SE 1999 4 dr auto air loaded \$4K \$9700 (248) 547 4146</p> <p>GRAND AM 2000 SE 4 dr CD rear spoiler red excellent cond 40K \$9900 734 778 0509</p> <p>GRAND PRIX 1999 GT loaded ready to roll you'll love this one \$14 988 <i>RedHoban</i> Westland (734) 721 1144</p> <p>GRAND PRIX 1994 GTP black loaded 54K miles exc cond \$5000 734 525 5092</p> <p>GRAND PRIX GTP 1997 4 dr white car w/taupe leather inte rior 58K miles exc cond \$10 000 (248) 561 2676</p> <p>GRAND PRIX GTP 1997 White chromes spotless 100k miles \$7200 (248) 363 6588</p> <p>GRAND PRIX 1994 Immaculate V6 new transmission air \$5 995 Mon Fri 9-5 30 248 577-3290</p> <p>GRAND PRIX 1993 SE 4 door sedan 92k mi \$3750 No rust well maintained newer battery tires alternator Power locks/ windows cruise keyless entry & more After 4 30 248-299 8336</p>	<p>868 Pontiac</p> <p>BONNEVILLE 1997 Clean loaded leather sunroof New tires \$9600 566-778 0495</p> <p>BONNEVILLE 1993 gray all power new tires very good cond \$4 200 (734) 981 2381</p> <p>BONNEVILLE 1994 SE all power ABS AM FM cassette new tires brakes 6 cyl Exc cond \$5000 248 547 8035</p> <p>BONNEVILLE 1995 SE fully equipped leather 75K miles \$5 500 248 449 8108</p> <p>BONNEVILLE SE 1995 Tan 4dr Colorado car never seen Mich winter Air all power new tires 3 8L V6 remote start 116k miles \$4 500 (734) 777 2523</p> <p>FIERO 1984 Show Room Cond 16k miles stored almost new \$6500/best 248-967 1428</p>	<p>872 Toyota</p> <p>CAMRY 1994 4 dr ex power Sandstone hv a/c \$5495 (734) 731 9888</p> <p>CAMRY LE 1995 Station 4 cyl 50 000 origi Loaded \$12 900 248-461 1144</p> <p>CELICA 2001 GTS moon low miles summ \$19 988 <i>RedHoban</i> Westland (734) 721 1144</p> <p>CELICA GTS 2000 CD auto sunroof 18k cond \$17 500 734-461 1144</p> <p>COROLLA 1999 39 0 ps/pb power windows \$8600 or best 734 461 1144</p> <p>COROLLAS 1999 auto power certified from <i>RedHoban</i> Westland (734) 721 1144</p>
---	---	---	---	--

SATURN

Delivers Value

Participating In "PULL AHEAD" Lease Program

0% APR Financing UP TO 60 Months

for qualified buyers on all 2002 Saturn L200's

- Automatic • Air • 8 speaker CD player
- Power windows & door locks with Saturn Security System
- Head Curtain Air Bags
- ABS with Traction Control
- Cruise control
- Dent-resistant front fenders and door panel

Lease a 2002 L200*

\$259/ month for 39 months, due at \$199/ lease signing	or	\$217/ month for 39 months, due at \$199/ lease signing.
---	----	--

(No security deposit required. Tax, title and license are extra.)

Take delivery by 4/30/02 Finance term limited *Lease payments based on specially equipped 2002 L200 with MSRP of \$19 185 Thirty nine monthly payments for L200 retail lease total \$10 101 39 monthly payments for employee lease total \$8 463 Option to purchase at lease end for an amount to be determined at lease signing Primary lending source must approve Take delivery by 4/30/02 Mileage charge of \$ 20 per mile over 39 000 miles Lessee pays for excess wear Payments may be higher in some states Not available with other offers All current GM S rules apply ©2002 Saturn Corporation

SATURN OF PLYMOUTH
9301 Massey Drive, Plymouth
(Ann Arbor Road & I-275)
734-453-7890

SATURN OF FARMINGTON HILLS
24730 Haggerty, Farmington Hills
(Haggerty, N of Grand River)
248-473-7220

...and it all here

Observer & Eccentric CLASSIFIED ADVERTISING
1-800-579-SATURN
FAX YOUR AD 734 953-2232
INTERNET ADDRESS www.observerandeccentric.com

ALL THIS AND A FRIENDLY COMPETENT SALES STAFF

GOODMAN SAAB

2002 9-5



LEASE A
2002 SAAB 9-5
4-DOOR - GMS

\$299* PER MO.
36 MONTHS

\$1295 Total Due at Lease Inception w/Olds
Loyalty. \$1795 w/Saab Loyalty. \$2295 without.

LEASE A
2002 SAAB 9-5
4-DOOR - NON-GMS

\$359* PER MO.
36 MONTHS

\$3000 Total Due at Lease Inception
(includes down pmt., sec. dep., acq. fee & 1st mo. pmt.)

2002 SE Convertible

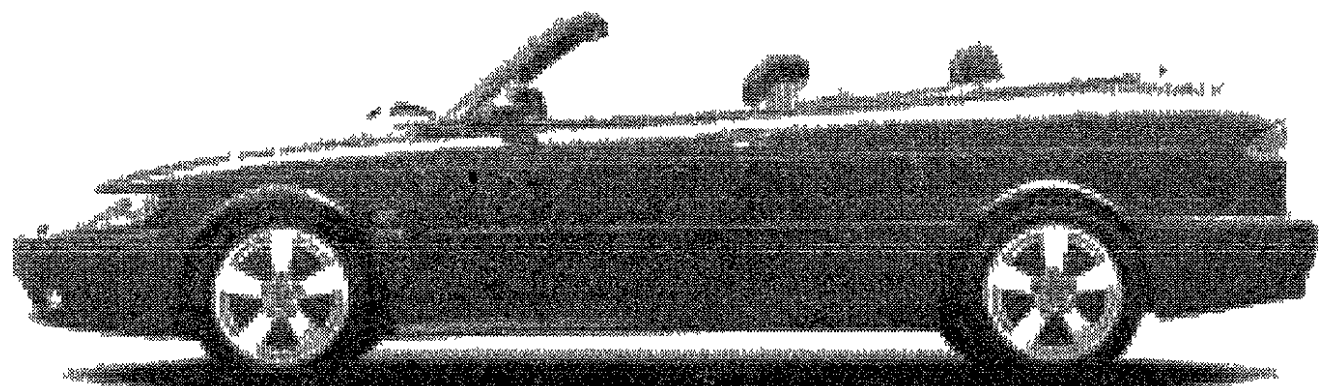

LEASE A
2002 SAAB SE
CONVERT. - GMS

\$359* PER MO.
36 MONTHS

\$854 Total Due at Lease Inception w/Olds
Loyalty. \$1354 w/Saab Loyalty. \$1854 without.

LEASE A
2002 SAAB SE
CONVERT. - NON-GMS

\$399* PER MO.
48 MONTHS

\$3295 Total Due at Lease Inception
(includes down pmt., sec. dep., acq. fee & 1st mo. pmt.)



**TOP CUSTOMER
SATISFACTION
IN MICHIGAN
TWO YEARS
IN A ROW**

Based on sales of 225 units or more.

**Call a member of our
Professional Team**

Scott Mayes

8 years SAAB Sales Experience
Gold Level Sales

Brad Tanenbaum

5 years SAAB Sales Experience
Gold Level Sales

Mike Moore

3 years SAAB Sales Experience
Gold Level Sales

Mercedes Cisneros

2.5 years SAAB Sales Experience
Gold Level Sales

Michael Denney

13 years Auto Sales Experience

0.0% APR AVAILABLE

For 36 months w/approved credit

*With approved credit Plus tax, title, and license 10,000 miles per year, 20¢ per mile over Offer expires 4/30/02

GOODMAN SAAB



3120 WASHTENAW • ANN ARBOR • 734-971-8100

www.goodmanauto.com



SAVE A LOT WITH BOB JEANNOTTE

GM PULL AHEAD LEASE PROGRAM IS BACK!!!
\$750* PONTIAC-BUICK-GMC LOYALTY BONUS
FOR CURRENT PONTIAC-GMC LESSEES

\$3002 Rebates
or
0% APR
on select models

PONTIAC • PONTIAC • PONTIAC • PONTIAC • PONTIAC • PONTIAC • PONTIAC

2002 FIREBIRD

Air conditioning, five speed manual transmission, 38 V6 engine, power windows, power locks, tilt wheel, cruise control, AM/FM stereo w/CD 16 aluminum wheels. Stock #020775

SALE PRICE \$16,395* **GM SALE PRICE \$15,584***

36 Mo. Smart Lease \$197**
 Due at Lease Signing \$395*

Includes \$750 Pontiac Lease Loyalty Bonus

2002 GRAND AM SE COUPE

Air conditioning, AM/FM CD, power locks, rear defrost, rear spoiler, 2.2 18 valve engine, five speed, manual. Stock #020653

SALE PRICE \$13,595* **GM SALE PRICE \$12,917***

36 Mo. Smart Lease \$197**
 Due at Lease Signing \$395*

Includes \$750 Pontiac Lease Loyalty Bonus

2002 GRAND PRIX SE SEDAN

Air conditioning, power windows, power locks, four speed tilt wheel, 3.1 V6 AM/FM cassette. Stock #020677

SALE PRICE \$17,195* **GM SALE PRICE \$16,429***

36 Mo. Smart Lease \$237**
 Due at Lease Signing \$173**

Includes \$750 Pontiac Lease Loyalty Bonus

2002 AZTEK

Air, auto trans, power windows, power locks, tilt, cruise, AM/FM stereo w/CD, remote keyless entry, 1.8 V4. Stock #021977

SALE PRICE \$17,995* **GM SALE PRICE \$17,125***

36 Mo. Smart Lease \$256**
 Due at Lease Signing \$175**

Includes \$750 Pontiac Lease Loyalty Bonus

2002 MONTANA

Air automatic, power windows, power locks, cruise, tilt, rear defrost, remote keyless 6 pass seating. AM/FM CD. Stock #020047

SALE PRICE \$18,595* **GM SALE PRICE \$17,626***

36 Mo. Smart Lease \$254**
 Due at Lease Signing \$176**

Includes \$750 Pontiac Lease Loyalty Bonus

BUICK • BUICK • BUICK • BUICK • BUICK • BUICK • BUICK • BUICK • BUICK

2002 LESABRE CUSTOM

Power windows & locks, tilt, cruise, air conditioning, AM/FM cassette, 3800 V6, power drivers seat & more. Stock #023541

SALE PRICE \$19,999* **GM SALE PRICE \$19,111***

36 Mo. Smart Lease \$423**
 Due at Lease Signing \$213**

Includes \$750 Buick Lease Loyalty Bonus

2002 PARK AVENUE

Power windows, locks, tilt, cruise, leather 3800 V6 CD/cassette, power seat, heated seats, keyless remote air, On-Star traction control, full instruments. Stock #023414 WAS \$36,497

SALE PRICE \$29,995* **GM SALE PRICE \$28,678***

36 Mo. Smart Lease \$423**
 Due at Lease Signing \$213**

Includes \$750 Buick Lease Loyalty Bonus

2002 CENTURY CUSTOM

3100 V6, automatic, air, tilt, cruise, power windows & locks, power locks, AM/FM cassette, mats & much more. Stock #023523

SALE PRICE \$17,199* **GM SALE PRICE \$16,427***

36 Mo. Smart Lease \$269**
 Due at Lease Signing \$139**

Includes \$750 Buick Lease Loyalty Bonus

2002 REGAL LS

Power windows & locks, tilt, cruise, automatic air, 3800 V6 leather, AM/FM CD, keyless entry, aluminum wheels & more. Stock #023253

SALE PRICE \$20,995* **GM SALE PRICE \$20,135***

36 Mo. Smart Lease \$285**
 Due at Lease Signing \$198**

Includes \$750 Buick Lease Loyalty Bonus

2002 RENDEZVOUS

V6 power windows & locks, tilt, cruise, air conditioning, rear defrost, keyless entry, rear wiper, AM/FM CD & more. Stock #023493

SALE PRICE \$20,899* **GM SALE PRICE \$19,893***

36 Mo. Smart Lease \$270**
 Due at Lease Signing \$194**

Includes \$750 Buick Lease Loyalty Bonus

GMC TRUCK • GMC TRUCK • GMC TRUCK • GMC TRUCK • GMC TRUCK

2002 SONOMA PICKUP

Vortec 2200 four cylinder engine, manual trans, air, tilt, cruise, alum wheels, deep tint glass, AM/FM CD player. Stock #22105

SALE PRICE \$11,467* **GM SALE PRICE \$10,848***

36 Mo. Smart Lease \$169**
 Due at Lease Signing \$189**

Includes \$750 GMC Lease Loyalty Bonus

2001 SIERRA 1 TON 4x4 DUALY EXT. CAB

Vortec 6000 V8 engine, automatic, air, tilt, cruise, cooling fan, spray on bed liner, power windows, power locks, power mirrors, power seats, HD interior pkg. & more. Stock #013344

SALE PRICE \$28,995* **GM SALE PRICE \$26,495***

36 Mo. Smart Lease \$429**
 Due at Lease Signing \$240**

Includes \$750 GMC Lease Loyalty Bonus

2002 YUKON 4X4

Vortec 4800 V-8 engine, air power windows, locks, mirrors, tilt, cruise, AM/FM & CD player & much more. Stock #022364

SALE PRICE \$29,995* **GM SALE PRICE \$28,524***

36 Mo. Smart Lease \$429**
 Due at Lease Signing \$240**

Includes \$750 GMC Lease Loyalty Bonus

2002 SIERRA PICK-UP

Automatic transmission, air conditioning, vortec 4800 V6, power steering, power windows, AM/FM & more. Stock #22102

SALE PRICE \$15,479* **GM SALE PRICE \$14,800***

36 Mo. Smart Lease \$224**
 Due at Lease Signing \$197**

Includes \$750 GMC Lease Loyalty Bonus

2002 ENVOY 4x4

Vortec 4200 engine, auto trans, dual zone A/C, pwr windows, locks, mirrors & seat tilt & cruise, keyless entry, AM/FM CD player & much more. Stock #28404

SALE PRICE \$26,995* **GM SALE PRICE \$25,794***

36 Mo. Smart Lease \$349**
 Due at Lease Signing \$224**

Includes \$750 GMC Lease Loyalty Bonus

JEANNOTTE PONTIAC • BUICK GMC TRUCK

(734) 453-2500
WWW.JEANNOTTE.COM

14949 Sheldon Road • (between M-14 & 5 Mile Road) • Plymouth

GM Employees
GMS • GMD • PEP
 Suppliers Welcome
 Hours: Mon. & Thurs. 9-9
 Tues., Wed., Fri. 9-6

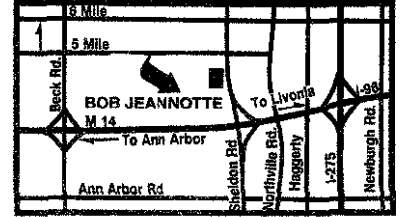

ATTENTION: ALL FORD LEASE CUSTOMERS INTERESTED IN...

- Early Termination
- CONCERNED ABOUT...
- Over Mileage
- Excess Wear and Tear

OR...
"Just Got To Have A New One!"
WE CAN HELP!

JACK DEMMER FORD
 ON MICHIGAN AVENUE IN WAYNE

SPRING INTO A NEW LEASE
JACK DEMMER FORD

Contact your Jack Demmer Ford Salesperson or if you leased from any other Ford Dealer contact Fae or Nicole in our Leasing Office.

<p>2002 FOCUS SE 4 DR.</p> <p>ZERO DOWN \$1500 DOWN</p> <p>\$229.28** \$193.90**</p> <p>185 FOCUS AVAILABLE</p> <p>NOW... \$12,047.80*</p> <p>Off Lease Buy • Ford Employee or Eligible Family Member</p> <p>0% Financing Available</p>	<p>2002 TAURUS SES</p> <p>ZERO DOWN \$1500 DOWN</p> <p>\$262.84** \$218.54**</p> <p>174 TAURUS AVAILABLE</p> <p>NOW... \$15,807*</p> <p>Off Lease Buy • Ford Employee or Eligible Family Member</p> <p>0% Financing Available</p>	<p>2002 EXPLORER 2 DR SPORT</p> <p>ZERO DOWN \$1500 DOWN</p> <p>\$314.31** \$268.59**</p> <p>271 EXPLORERS AVAILABLE</p> <p>NOW... \$18,020*</p> <p>Off Lease Buy • Ford Employee or Eligible Family Member</p> <p>0% Financing Available</p>	<p>2002 F-150 SC</p> <p>ZERO DOWN \$1500 DOWN</p> <p>\$240.44** \$193.90**</p> <p>148 F-150S AVAILABLE</p> <p>NOW... \$16,770*</p> <p>Off Lease Buy • Ford Employee or Eligible Family Member</p> <p>0% Financing Available</p>
<p>2002 WINDSTAR LX</p> <p>ZERO DOWN \$1500 DOWN</p> <p>\$307.76** \$264.71**</p> <p>102 WINDSTARS AVAILABLE</p> <p>NOW... \$19,347.30*</p> <p>Off Lease Buy • Ford Employee or Eligible Family Member</p> <p>0% Financing Available</p>	<p>2002 RANGER XLT SC</p> <p>ZERO DOWN \$1500 DOWN</p> <p>\$196.66** \$151.25**</p> <p>148 RANGERS AVAILABLE</p> <p>NOW... \$11,589.50*</p> <p>Off Lease Buy • Ford Employee or Eligible Family Member</p> <p>0% Financing Available</p>	<p>2002 EXPLORER XLS 4 DR</p> <p>ZERO DOWN \$1500 DOWN</p> <p>\$289.83** \$248.01**</p> <p>271 EXPLORERS AVAILABLE</p> <p>NOW... \$20,448.00*</p> <p>Off Lease Buy • Ford Employee or Eligible Family Member</p> <p>0% Financing Available</p>	<p>2002 F250 4X4 CREW CAB</p> <p>ZERO DOWN \$1500 DOWN</p> <p>\$240.44** \$193.90**</p> <p>148 F-250S AVAILABLE</p> <p>NOW... \$25,103.50*</p> <p>Off Lease Buy • Ford Employee or Eligible Family Member</p> <p>0% Financing Available</p>

MODEL	DOWN PAYMENT	TOTAL DUE AT INCEPTION
RANGER SC	0 Down	\$406
	\$1500	\$1950
WINDSTAR	0 Down	\$585
	\$1500	\$2130
EXPLORER XLS	0 Down	\$806
	\$1500	\$2052
F150 SC	0 Down	\$514
	\$1500	\$2055
TAURUS	0 Down	\$448
	\$1500	\$1950
FOCUS	0 Down	\$382
	\$1500	\$1922
EXPLORER SPORT	0 Down	\$592
	\$1500	\$2134

JACK DEMMER FORD

CALL 1-800-ASK-FORD!
www.aplanheadquarters.com!
Ph. 734.721.2600

SALES
 Mon. & Thurs. 8am-9pm
 Tues., Wed., Fri. 8am-6pm

SERVICE
 Mon. & Thurs. 8am-8pm
 Tues., Wed., Fri. 8am-6pm

